

## Review of Wire-Mesh Tomography in Different Experiments

Navintiran Rajan<sup>1</sup>, Ruzairi Abdul Rahim<sup>1\*</sup>, Mohd. Shukri Manaf<sup>1</sup>, Mohd. Hafiz Fazalul Rahiman<sup>2</sup>, Mohd. Shukri Manaf<sup>1</sup>, Anita Ahmad<sup>1</sup>, Yusri Md. Yunus<sup>1</sup>, Sallehudin Ibrahim<sup>1</sup>, Yasmin Abdul Wahab<sup>3</sup>, Mimi Faisyalini Ramli<sup>4</sup>, Suzanna Ridzuan Aw Abdullah<sup>5</sup>

<sup>1</sup>School of Electrical Engineering, Faculty of Engineering, Universiti Teknologi Malaysia, 81310 UTM Skudai

<sup>2</sup> Faculty of Electrical Engineering Technology, Universiti Malaysia Perlis, Pauh Putra Campus, 02600 Arau, Perlis

<sup>3</sup> Faculty of Electrical & Electronic Engineering, Universiti Malaysia Pahang, Pekan Campus, 26600 Pekan, Pahang

<sup>4</sup> Faculty of Technology Engineering, Universiti Tun Hussein Onn, Campus Pagoh.

<sup>5</sup> Faculty of Electrical & Automation Engineering Technology, Terengganu Advanced Institute Technical College (TATIUC), Telok Kalong, 24400 Kemaman, Terengganu

Corresponding author\* email: ruzairi@fke.utm.my

Accepted 3 March 2021, available online 31 March 2021

### ABSTRACT

Wire-mesh tomography is completely new to the tomography field. First founded in 1998, the wire-mesh tomography had been used in several sectors as secondary optional sensors. This sensor can be used to gain void fraction distribution in multiphase flow visualization. By using tomography techniques, several measurements like velocity or phase fraction boundaries can be determined and analysed. The sensor basically built perpendicularly as transmitter and receiver layer located above and below respectively. With wires made of tinned copper and 16 sensors for each layer, the tomography is considered low-cost, easy built and can sustain in a harsh environment to investigate multiphase flow. As an instantaneous tomography method, wire-mesh tomography has advantage in speed but has less image resolution because classic wire-mesh tomography image reconstruction methods only provide same amount of pixels as measurement number. In order to increase image resolution, a new image reconstruction method based on sensitivity map is proposed, which is of providing more pixels (sub pixels) by solving inverse problem with capacitive wire-mesh tomography image reconstruction. The image reconstruction algorithms, including the traditional wire-mesh direct image reconstruction algorithm, the linear back projection, the projected Landweber iteration, and the total variation based iteration, are conducted and the results are compared each other.

**Keywords:** Wire-mesh, multiphase flow, phase fraction, image resolution, sub pixels, linear back projection

### 1. Introduction

Process tomography technique has widely used to investigate multiphase flow behaviour in oil and gas industries, chemical industries and also biotechnology industries. An intrusive wire-mesh conductive tomography sensor is an alternative technique which was designed by H. M. Prasser in 1998 [1]. This sensor can use to gain void fraction distribution in multiphase flow process visualization. Multiphase flow describes the two or more physically distinct simultaneous flow mixtures in a process column. The mixtures can be the combination of one or more components of gaseous, liquid, or solid.

By using tomography techniques, several measurements like velocity or phase fraction boundaries can be determined and analysed. Thus, various tomography sensors used for the purpose of obtaining information such as phases flow patterns, phases flow velocity and phases boundaries investigation. Wire-mesh sensor (WMS) is an alternative technique and is absolutely new to the tomography systems. A wire-mesh sensor is basically built with two layers perpendicularly located which were stretched over the process column as the transmitter layer and the receiver layer. The layers of wires were installed orthogonal to each other without any physical contact. The first wire-mesh type tomography sensor was experimented to measure fluid conductivity.

The wire-mesh technique allows investigating the flow nature with good degree of details due its good spatial and temporal resolution depends on the grid size of the designed wire-mesh sensor. A collection of papers that discussed the wire-mesh tomography in several fields were reviewed to have a scope on upgrading the sensor.

## 2. Literature review

When it comes to wire-mesh tomography, the basic construction of wire-mesh sensor is the same. The basic construction is to have 2 layers perpendicularly located where one is transmitter and the other is receiver. The first paper is reviewed for the study of trickle bed reactors which have fixed bed depth to measure the presence of conductive liquid between them [2]. The working method of the sensor is discussed here. As current is supplied successively to each wire in the transmitter plane, a multiplexer circuit activates one by one all the wires of the second (receiver) plane. Only one crossing point is measured at a time, the other not concerned wires of each plane being connected to the ground. The measuring cycle finishes when current has been supplied to all the transmitter wires [5].

The wires are made up of stainless steel and each layer consists of 19 wires so total of 313 measurable crossing points. Concerning temporal resolution, as only one receiver wire is measured at a time in the conceived device, the duration of a measuring cycle depends on the number of cross points to be considered. For a complete scan using the whole 38 wires, 10–15 seconds are necessary.

In the experimental investigation of horizontal gas-liquid flow by wire mesh sensor [3], the wire-mesh technique based on capacitance measurements is applied to study two-phase slug flows in horizontal pipes. Based in raw data measured it is possible to extract some specific parameters of interest.

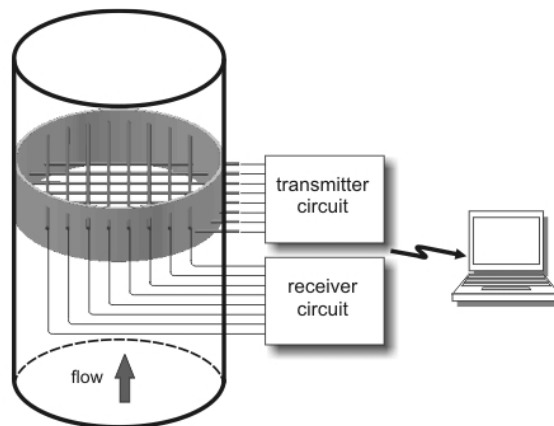

Figure 1. Schematic representation of wire mesh sensor

The voltage levels measured by the wire-mesh sensor are stored in a three-dimensional matrix at the computer memory  $V(i,j,k)$ , with  $k$  being the time index and  $i$  and  $j$  spatial indexes respectively. Wire-mesh sensor electronics generate voltages with a logarithmic response, which is assumed to be previously known and adjusted to a linear response. In this way, the measured voltages are proportional to the electrical permittivity  $\epsilon$  of each crossing point, which in turn is proportional to the void fraction. In order to convert the measured voltages to permittivity values and further obtain the phase fraction distributions, a calibration routine is used. First, a measurement of a matrix  $V_L$  for a substance of low permittivity covering the whole sensor cross-section is performed.

Then a  $16 \times 16$  wire mesh sensor analysed for capacitance distribution in a cylindrical pipe [4]. A tomography system device applies the principle of a wire-mesh sensor has been built to analyze the distribution of the dispersion of capacitance occurring within a cylindrical pipe. This wire-mesh sensor system is built from two horizontal layers of wires allowing, by local capacitance measurements, to detect the presence of a capacitance fluid between them. The wire-mesh sensor is made of copper wire which is divided into two layers: transmitter and receiver layer. Each layer is composed of 16 pieces of wire are parallel. The image resolution of the wire-mesh is obtained from the number of cross points between the electrode wires, so using  $16 \times 16$  wire configuration, 256 points of resolution are obtained.

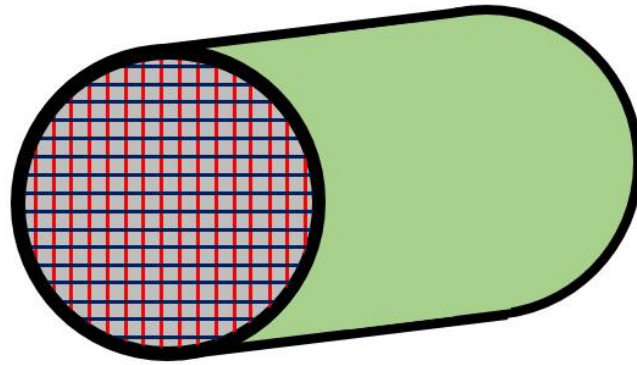

Figure 2. Wire-mesh sensor in a cylindrical pipe

The signal that received on the transmitter wire is still in a current signal, whereas in a digital system the signal must be read as the voltage signal, so to change it can use the current converter circuit that can convert current into voltage signal. A simple circuit consisting of an op-amp coupled with a capacitor and a resistor as feedback can convert a current into a voltage whose value is proportional each other. Fig. 3 is a schematic of a current-converting circuit into a voltage or I-V converter.

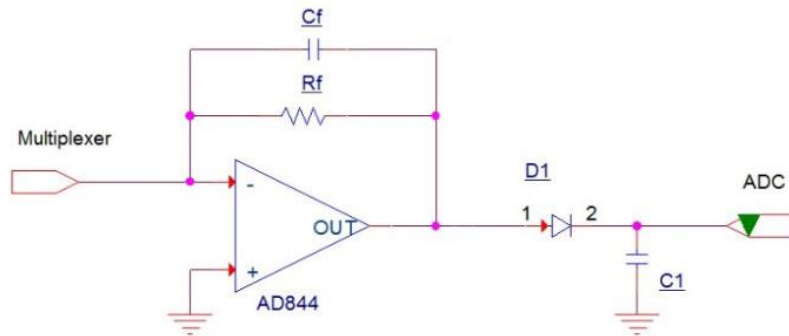

Figure 3. Schematic of a current-converting circuit into a voltage or I-V converter

By using equation (1), we can get the capacitance value that occur in cross-section wire-mesh sensor.

$$V_o = -V_i \frac{C_w}{C_f} \quad (1)$$

The output voltage ( $V_o$ ) is the output voltage of op-amp which will be read by ADC, the input voltage ( $V_i$ ) is the voltage coming from the receiver wire. Capacitor wire ( $C_w$ ) is representing capacitance of the wire-mesh sensor whose value varies according to the flowing substance between the two wire receivers and the transmitter. Because the output signal from the I-V converter is still an analog signal, it needs to be converted into digital form using ADC contained in microcontroller. This is needed because the computer that will process the data into 2-dimensional image cannot read analog signal and only able to read signal in digital form. The data received by the computer is still in a voltage value, to get the capacitance value from the wire-mesh sensor it is necessary to change the data using equation (1). This equation is inserted into the code script in the python 2-dimensional image program, so it is not just a program to create image but python software also performs mathematical calculations to get measured capacitance values in wire-mesh sensors.

While the other papers reviewed had discussed more on the different setups, variation in construction and number of sensors, some were experimenting on improving the image resolution for wire-mesh sensors. Wire mesh tomography labeled as an instantaneous tomography method, wire mesh tomography has advantage in speed but has less image resolution because classic wire-mesh tomography image reconstruction methods only provide same amount of pixels as measurement number. In order to increase image resolution, a new image reconstruction method based on sensitivity map is proposed, which is of providing more pixels (sub pixels) by solving inverse problem with capacitive wire-mesh tomography image reconstruction [9].

Capacitance wire-mesh sensor is similar to ECT sensor in working principle, which measures capacitance between different electrode pairs and reconstructs permittivity distribution of sensor cross-section. The target of image reconstruction is to obtain permittivity distribution from measured capacitance data. It is a typical ‘inverse problem’. The opposite ‘forward problem’ is to calculate capacitance data from permittivity distribution, which is generally solved by using the finite element method (FEM) or practical experiment. Using much more fine pixel mesh grid may help to improve the resolution of reconstructed image. It brings the possibility to obtain detailed information of reconstructed wire-mesh tomogram.

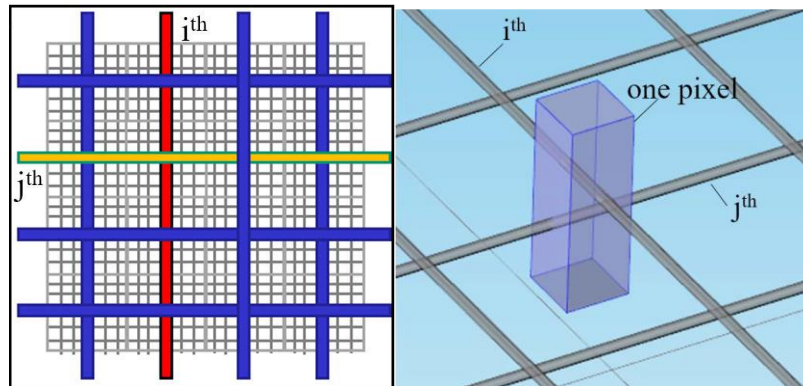

Figure 4. Sub-pixel meshing strategy for wire-mesh tomography image reconstruction. Left, 2D illustration of wire-mesh; right, 3D view of wire-mesh in COMSOL Multiphysics with a pixel marked

### 3. Data analysis

The previous experiment was conducted with the similar basic construction of wire-mesh sensor as [1] with a much similar goal which is to study multiphase flow of liquid. In [4], the data of the experiment was obtained by a demultiplexer to convert the value of voltage into a digital form so that the digital value used to reconstruct the tomogram image. There are 4 types of fluid applied in wire-mesh sensor such as free air, distilled water, tap water, and 1 mol of salt solution. This variation aims to determine the ability of the sensor to read fluid changes from non-conductive (air) to the most conductive fluid (salt solution), and of course determines the capacitance distribution of each fluid.

Figure 5.a is the result image of the wire-mesh sensor with air media filling the cylinder pipe. A picture with white circle and black edges is the approximation of a cylindrical pipe shape, the shape of this circle is not perfect, it has a square edge shape, this is because each square represents the cross point of the receiver and transmitter wires, moreover if all the squares are combined it will become a 2-dimensional image of the cylindrical pipe. The color bar on the right picture is the image legend, showing the value of the capacitance that changed into the color form, each color having its own value, for the color in the bottom position (white) it's means has low capacitance while the top position (blue) means highest value.

Filling cylinder pipe using free air causes the resulting image become mostly white (Fig 5.a) or in other word air has zero capacitance. In this case, its mean not absolutely zero, but there are measurement limits. Wire-mesh sensor system cannot measure at a certain range, the system has a weakness in measuring capacitance on gas phase, especially free air, because the capacitance of air is too small for system to be measured. Therefore, the system will automatically send zero data to the computer that causes the resulting 2-dimensional image being white. Not all measuring points are zero, at some point indicate the sensor still capable to measure the capacitance value of the air, even though its looks vague with color pattern is light brown, this color still can identified with capacitance value at range 0 to 15 pF.

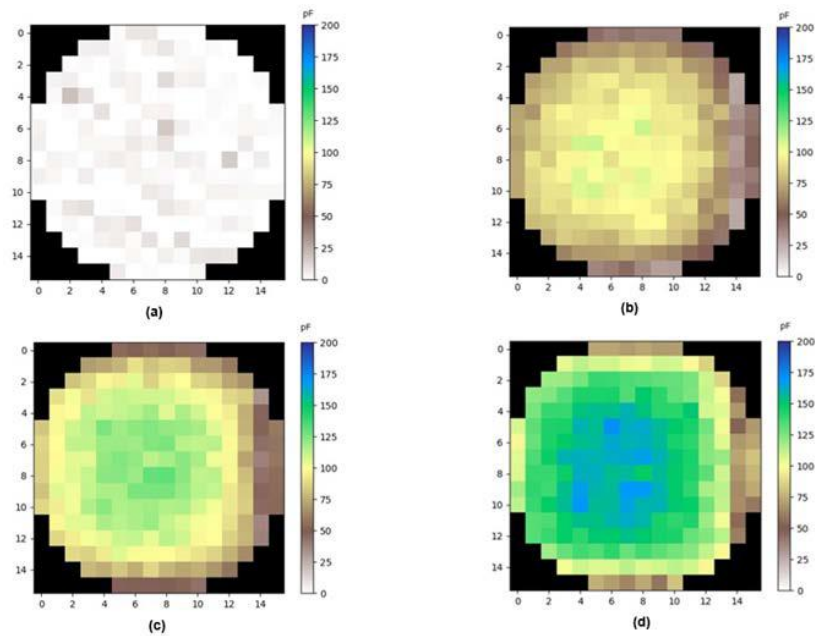

Figure 5. Images generated by wire mesh sensors using (a) free air, (b) distilled water, (c) tap water, (d) salt solution 1 mol.

When using distilled water as media, the color pattern on the resulting image is increasingly visible, its very contrast if compared with results images using free air. The results image (Figure 5.b) has 3 main colors i.e., brown, yellow and green. The composition of the three colors is dominated by the yellow color in middle of the image, with brown color in edge of the image, while the green color looks vague in the center of image with total pixel image less than ten pixels. The quantity of the measured capacitance value at the sensor is around 100 pF in the center area and 50 pF of the edge.

Increased capacitance occurs when using tap water. Figure 5.c is an image produced by the system using tap water media. In this picture the number of color patterns are equal with distilled water. the distinguishes attribute compared from the previous image are the area of green color are widened, this color pattern is almost half of the yellow pattern in the middle area of the image, this indicates that the value of capacitance on the sensor is increasing due to pouring tap water on cylinder pipe.

A new pattern is created when the salt solution is applied in the pipe. Figure 5.d is the image created by system using a salt solution with molarity level 1 mol. There are 4 color patterns filling the image including brown, yellow, green and blue, without any white color that fills the image. With more conductive the fluid has been applied, affect raise the capacitance value are obtained, this is indicated by the appearance of a new color just like blue. The highest capacitance of the blue color measured about 165 pF, but the dominant color is green. The distribution pattern of the capacitance in the salt solution remains the same as the previous image pattern, the highest conductivity is at the center of image, shown in blue.

In paper [6], a much simpler but efficient experiment was done to investigate the liquid level visualization using color scaling technique as [3]. But in [3] color scaling used to measure capacitance and reconstruct the image while [6] shows 4 type of liquid level and the tomogram images. The phantom image was used to clearly describe the experimental situation and the liquid/gas interface level. The results are shown in Fig. 6 where AL denotes the liquid area (in percentage). Two distinct regions of the liquid/gas two phase flows in the process column were well depicted in the tomogram result image B. But, an observation of the liquid/gas interface level shows that there is an overestimation of the level of liquid/gas region's interface with the calculated error was about 3.65%. The tomogram result image of C is still consists of the periphery crossing point error as discussed in tomogram result image B, but the few centre crossing points above the liquid/gas interface is the major of the sensing error. Those crossing points should not be indicated as liquid phase, but the sensing values of those crossing points are mostly near to interface value.



	Void Fraction	Phantom	Tomogram
A		 $A_L = 100\%$	 $A_L = 96.76\%$
B		 $A_L = 74.23\%$	 $A_L = 77.88\%$
C		 $A_L = 46.67\%$	 $A_L = 52.78\%$
D		 $A_L = 0\%$	 $A_L = 0\%$

Figure 6. Illustrations of the void fraction, phantom and the tomogram results

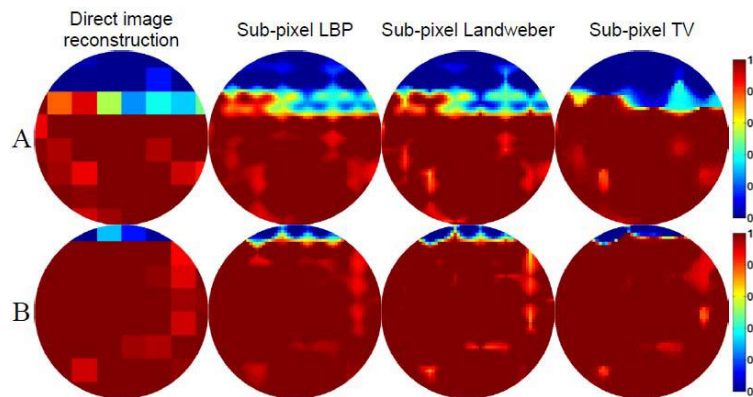

Figure 7. 8 x 8 sensor reconstruction result of dynamic experiment

Figure 7 is obtained from [9] and this result is based on four different types of flow and the image reconstruction method. This experiment is for sensitivity for the pixels in image reconstruction. It is found that different algorithms give out different performance of image quality and the qualities of the sensitivity map based sub-pixel reconstructions are smoother and have more details than those from the direct image reconstruction.

## 4. Discussion

### 4.1 Limitation

With wire mesh sensor being a low-cost tomography device, it is sure has its own limitations. Other than having lower resolutions in certain circumstances, the characteristics of the construction itself have the limitations. Its intrusive design is a limitation that hard to neglect it [1], [2]. Two sets of wire planes crossing the sectional area of the column will surely affect the liquid flow pattern. The effect is however moderate as the wires are smaller than the particle diameter, and the distance between them is five times this diameter. With the actual configuration, only about 6.5% of the reactor cross-section is occupied by the wires.

Wire mesh sensor had some problems to quantify liquid velocity. Conductance is a function of the surface occupied by the liquid around the crossing points but is independent of its velocity. Also it is hard for this tomograph

device to work with porous particles: once wetted, porous particles remain filled by water and so therefore conduct electricity. As presented here, the wire mesh tomography device is unable to make any difference between a set of wet porous particles and an actual liquid filament flowing through the bed [1].

#### 4.2 Discussed Results

From the results of [7], the accuracy of WMT measurement due to the intrusive feature can be identified approximately from the wire mesh tomography itself. It can be detected simultaneously even during the measurement. However, the alternative optical method is also utilized for low gas intensity range. The main finding is consisting of the dependence of flow disturbance level on the void fraction shape is presented. The wire-induced uniformity is found for wall-peak shape, while it is opposite for central peak shape. The disturbance level is increasing with the degree of non-uniformity.

The disturbance characteristic can be mainly classified by bubble motion modification and interfacial deformation. For bubbly flow, the low gas intensity zone (wallpeak void fraction shape) is characterized by the deceleration, while the high gas intensity zone (central-peak void fraction shape) is characterized by the deformation. Furthermore, the disturbance level on both bubble motion and deformation is reduced for bubble-slug transition.

In [9] and [10], the sub-pixel reconstruction can provide more detailed flow propagation information. Especially, the extra pixels which are obtained from sensitivity-based reconstruction contain the real geometric information of the wire-mesh sensor. In this case, the reconstructed sub-pixels can arguably be more authentic than those given by pure digital image processing algorithms.

Under the framework of sensitivity map based subpixel reconstruction, image reconstruction algorithms including the linear back projection (LBP), the Landweber iteration, and the total variation based regularization, are conducted by using static and dynamic experimental data and the results are compared each other and with those from the traditional wire mesh direct image reconstruction algorithm. Preliminary results regarding typical gas-liquid two-phase flow regimes show that sensitivity map based sub-pixel reconstructions are better than the traditional wire-mesh direct image reconstruction by providing better resolution, thus the new image reconstruction method can be helpful to improve the reconstruction quality of capacitive wire-mesh tomography.

In [6], the error of the tomogram result for phantom A may lead to misinterpreting the instantaneous flow situation as bubbly flow located at the top and east area of the result image, even though the actual measurement volume is completely filled with liquid in the process column. A careful observation of the result of the experimental data shows those crossing point values near to the sensor's wall were relatively lower than the others crossing point values that not at the periphery of the wire-mesh sensor. Therefore, the liquid/gas distributions at the periphery of the wire mesh sensor need to be determined by a calculation method that is different to the central crossing point measuring method. The tomogram results B and C from the wire-mesh sensor shown that an overestimation occurred slightly in the determination of phases interface compared to its phantom. However, the discrepancies are small and acceptable in this experiment.

## 5. Conclusion

Wire-mesh tomography technique provides reliable measurement of liquid/gas two-phase flow interface [6] and its void fraction, as a maximum error for liquid/gas two-phase flow. In order to improve the estimation of the gas-liquid interface using the wire-mesh tomography technique, a suitable image reconstruction algorithm needs to be studied. From [9], image reconstruction using subpixel is prioritized in order to improve the estimation of the gas-liquid interface using the wire-mesh tomography technique, a suitable image reconstruction algorithm needs to be studied in the future. Similar to [9], in [10] inverse method technique was studied to improve imaging quality and reduce image error. In addition, it also proves the effectiveness of this method for application in the measurement of oil-water two-phase flow with high water holdup. While sub pixel technique can be considered to improve image resolution, hardware changes such as modifying sensors would also help increase the sustainability of wire-mesh sensor.

## Acknowledgement

The authors would like to thank to Universiti Teknologi Malaysia for supporting the research study under UTMER Research Fund, vote number QJ130000.3851.19J53.

## References

- [1] H.-M. Prasser, A. Böttger, J. Zschau, A new electrode-mesh tomograph for gas-liquid flows, *Flow Meas. Instrum.* 9 (1998) 111–119.
- [2] Juan-David Llamas, Cédric P´erat, Francois Lesage, Mathieu Weber, Umberto D’Ortona, Gabriel Wild, Wire mesh tomography applied to trickle beds: A new way to study liquid maldistribution, *Chemical Engineering and Processing* 47 (2008) 1765–1770.
- [3] Marco J. da Silva, Uwe Hampel, Lúcia V. R. Arruda, Carlos E. F. do Amaral, Rigoberto E. M. Morales, Experimental Investigation of Horizontal Gas-Liquid Slug Flow by Means of Wire-Mesh Sensor, *J. of the Braz. Soc. of Mech. Sci. & Eng., Special Issue 2011, Vol. XXXIII / 237-240.*
- [4] Akbar Sujiwa, Endarko, Wire-Mesh 16 × 16 Capacitance Sensor for Analysis of Capacitance Distribution on Cylindrical Pipe, *The 3rd International Seminar on Science and Technology*, 2017.
- [5] Shangjie Ren, Hongcheng Liu, Chao Tan, Feng Dong, Tomographic Wire-Mesh Imaging of Water-Air Flow Based on Sparse Minimization, *IEEE SENSORS JOURNAL, VOL. 17, NO. 24, DECEMBER 15, 2017.*
- [6] M.H.F. Rahiman, L.T. Siow, R.A. Rahim, Z. Zakaria, Vernoon Ang, Initial Study of a Wire Mesh Tomography Sensor for Liquid/Gas Component Investigation, *J Electr Eng Technol.*2015; 10(5): 2205-2210.
- [7] Weerin WANGJIRANIRAN , Yuichi MOTEGI , Steffen RICHTER , Hiroshige KIKURA , Masanori ARITOMI & Kazuhiko YAMAMOTO, Intrusive Effect of Wire Mesh Tomography on Gas-liquid Flow Measurement, *Journal of NUCLEAR SCIENCE and TECHNOLOGY, Vol. 40, No. 11, p. 932–940, 2003.*
- [8] César Y. Ofuchi, Henrique K. Eidt, Carolina C. Rodrigues, Eduardo N. dos Santos 1, Paulo H. D. dos Santos, Marco J. da Silva, Flávio Neves, Jr., Paulo Vinicius S. R. Domingos, Rigoberto E. M. Morales, Multiple Wire-Mesh Sensors Applied to the Characterization of Two-Phase Flow inside a Cyclonic Flow Distribution System, *Sensors* 2019, 19, 193.
- [9] Weimin Lao, Lihui Peng, Yi Li, An image reconstruction method for improving resolution of capacitive wire mesh tomography, 978-1-5386-1620-8/17/\$31.00 ©2017 IEEE.
- [10] Qing Sun, Huaxiang Wang, Mesh Wire Tomography Combined with a Modified Sensitivity Map, 978-1-61284-896-9/11/\$26.00 ©2011 IEEE.
- [11] Kai Sun, Hai Gang Wang, Yi Li, A fast way to get sensitivity map of Wire-Mesh, 978-1-5386-6628-9/18/\$31.00 ©2018 IEEE.
- [12] P. P. Bhattacharjee and S. Sen, “Wire-Mesh Tomograph for Gas-Liquid Flow Measurement,” presented at the 2005 Annual IEEE INDICON, pp. 427-430, 2005.
- [13] H. Pietruske and H.-M. Prasser, “Wire-mesh sensors for high-resolving two-phase flow studies at high pressures and temperatures,” *Flow Meas. Instrum.*, vol. 18, no. 2, pp. 87-94, Apr. 2007.
- [14] C. G. Xie, N. Reinecke, M. S. Beck, D. Mewes, and R. A. Williams, “Electrical tomography techniques for process engineering applications,” *Chem. Eng. J. Biochem. Eng. J.*, vol. 56, no. 3, pp. 127-133, Feb. 1995.
- [15] Da Silva, M.J., Schleicher, E. and Hampel, U., 2007, “Capacitance wire-mesh sensor for fast measurement of phase fraction distributions”, *Measurement Science and Technology*, Vol. 18, pp. 2245-2251.
- [16] Da Silva, M.J., Thiele, S., Abdulkareem, L., Azzopardi, B.J. and Hampel, U., 2010, “High-resolution gas-oil two-phase flow visualisation with a capacitance wire-mesh sensor”, *Flow Measurement and Instrumentation*, Vol. 21, pp. 191-197.
- [17] Prasser H.-M., Misawa M., and Tiseanu I., 2005, “Comparison between wire-mesh sensor and ultra-fast x-ray tomograph for an air-water flow in a vertical pipe”, *Flow Measurement and Instrumentation*, Vol. 16, pp. 73-83.