

PAPER • OPEN ACCESS

Design and development of the Macpherson Proton Preve Magneto rheological damper with PID controller

To cite this article: I M Amiruddin *et al* 2017 *IOP Conf. Ser.: Mater. Sci. Eng.* **248** 012003

View the [article online](#) for updates and enhancements.

You may also like

- [The development of an outer multi-pole magneto-rheological damper with high dynamic range of damping force](#)
Shaogang Liu, Lifeng Feng, Dan Zhao et al.
- [Design and experiments of a novel magneto-rheological damper featuring bifold flow mode](#)
Kyongsol Kim, Zhaobo Chen, Dong Yu et al.
- [MR damper based implementation of nonlinear damping for a pitch plane suspension system](#)
H Laalej, Z Q Lang, B Sapinski et al.



The Electrochemical Society
Advancing solid state & electrochemical science & technology

242nd ECS Meeting
Oct 9 – 13, 2022 • Atlanta, GA, US
Presenting more than 2,400 technical abstracts in 50 symposia

ECS Plenary Lecture featuring M. Stanley Whittingham,
Binghamton University
Nobel Laureate – 2019 Nobel Prize in Chemistry

 Register now!



Design and development of the Macpherson Proton Preve Magneto rheological damper with PID controller

I M Amiruddin¹, M Pauziah¹, A Aminudin¹ and M H Unuh¹

¹Intelligent Dynamic and System (IDS) i-Kohza, Malaysia-Japan International Institute of Technology (MJIIT), Universiti Teknologi Malaysia, Jalan Sultan Yahya Petra, 54100 Kuala Lumpur, Malaysia

Abstract. Since the creation of the first petrol-fuelled vehicle by Karl Benz in the late nineteenth century, car industry has grown considerably to meet the industrial demands. Luxurious looks and agreeable rides are the primary needs of drivers. The Magneto-rheological damper balanced their damping trademark progressively by applying the damping coefficient depending on the control system. In this research, the control calculations are assessed by utilizing the MR damper. The capacity and reliability of the target force for the damper speed is investigated from control algorithm. This is imperative to defeat the damper limitation. In this study, the simulation results of the semi-dynamic MR damper with the PID controller shows better performance in sprung mass acceleration, unsprung mass acceleration and suspension dislodging with permitting over the top tyre acceleration. The altered model of the MR damper is specially designed for Proton Preve specifications and semi-active PID control. The procedure for the advancement incorporates the numerical model to graphically recreate and break down the dynamic framework by utilizing Matlab.

1. Introduction

The suspension of a ground vehicle includes parts that certify a versatile association amongst tyres and vehicle body. At the point when vibration is induced by the abnormalities on the road profile, this flexibility secures the auto body and the passenger [1]. One crucial part in a vehicle suspension that controls oscillations is the damper. Its primary function is to hold the abundance imperativeness from springs and tyres. Also, it removes the skipping impact of each wheel. Vibrations in the passenger compartment will be automatically minimized. The essential goals of the suspension are to give comfort to passengers and driver [2]. A semi-dynamic suspension is lighter, more passive and less complex than their dynamic accomplices [3]. In addition, semi-dynamic dampers are more ideal than current passive dampers in various applications. Semi-dynamic dampers are the cutting-edge car applications and they are observed to be marketable [4]. The diverse method for measuring information from a quarter car suspension framework [3] includes utilizing acceleration and displacement information. In this research, the damper is assessed in frequency and time domain. The capacity and consistency given by the MR damper are explored with control algorithm. This is essential to give a similar course of damper velocity and target force. To overcome the damper constraint, the control algorithm is adjusted and enhanced for its power in the quarter car structure. The segment of the PID controller utilized as a part of this research is for magneto rheological damper. The MR damper is specially designed for Proton Preve specifications with semi-active PID control which is new for Malaysian vehicles technology.



2.2 Magnetic flux line

The analysis is simplified to a single iteration analysis. The outside of the model parameter is presumed to be free of any flux leakage, and saturation of the material does not ensue. The ramification of flux leakage is demonstrated by creating a layer of air bordering the iron. The maximum radius of the iron shall be equal to or smaller than the air layer. The flux will work in parallel to the surface of the model’s parameter to satisfy the assumption defined in the previous section. The parallel flux boundary condition will enforce the assumption to be realized. Zooming to the flux path where the MR fluid is stored is shown in figure 2, illustrating that the flux lines concentration increase as the distance between adjacent flux lines becomes smaller. For this reason, it demonstrates the influence of the rheology properties of the MR fluid on the electrical coil in general and to the generated magnetic field for a more focused subject.

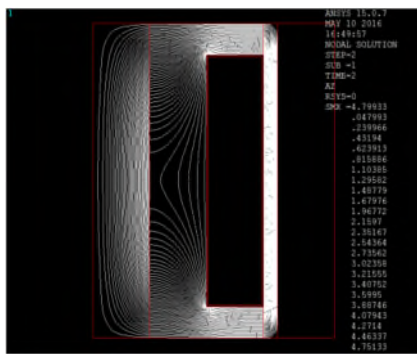

Figure 2. Magnetic flux lines.

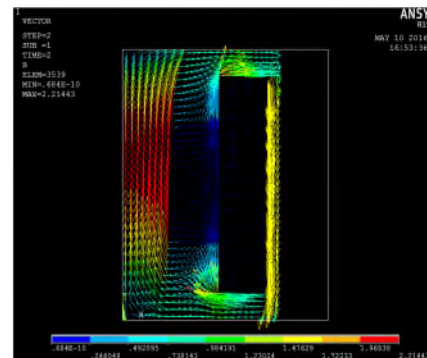

Figure 3. Magnetic flux lines in vector form.

In addition, figure 3 illustrates the direction change of magnetic flux lines in vector form upon entering the area that stores the MR fluid. Thus, the highest value of magnetic flux density is recorded along the area where the MR fluid is stored. At the moment the MR fluid becomes saturated, the concentration of the magnetic flux lines concentration decreases.

3. Modelling quarter car suspension system

Active suspension system for PROTON PREVE includes force actuators to generate the wavering force. The actuator is designed to fit the conventional PROTON springs and MR damper in the vertical connection for the two degree of freedom system. To improve the PROTON PREVE suspension system, the Arduino microcontroller is used. By tuning the PID controller designed in the system, the ride control and comfort of the vehicle will be better. A quarter car models is used in designing the suspension system as shown in figure 4, to simplify the one-dimensional spring-damper system.

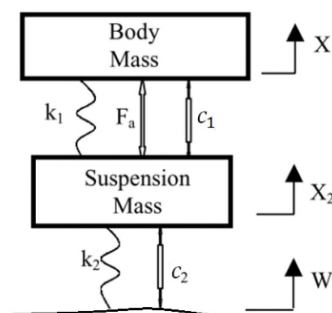

Figure 4. Quarter car model of Proton Preve

The passive suspension system, identified as the conversional suspension system is normally unable to dissipate large oscillations quickly. As tyre deformation is rather difficult to be measured in real condition, the simulation will help to generate and analyse the data. Road input which is also known as road disturbance W is represented as step input and speed bump. These inputs comply with the Malaysian standard of a road bump height i.e. 10 cm.

3.1. Transfer function modelling

The assessment of the system behaviour is crucial in estimating the feedback fault between simulation and experimental values of a designed controller. The stationary and transitional work regime systems can be defined with this approach. The mathematical model of the dynamics system obtained from the dynamic equation, which represents the Newton's Law as shown equation 1 and 2:

$$m_1 \ddot{x}_1 = -k_1(x_1 - x_2) - c_1(\dot{x}_1 - \dot{x}_2) + F_a \quad (1)$$

$$m_2 \ddot{x}_2 = -c_1(\dot{x}_1 - \dot{x}_2) + k_2(W - x_2) - k_1(x_1 - x_2) + c_2(\ddot{W} - \ddot{x}_2) - F_a \quad (2)$$

The application of Laplace transforms can be simplified by solving these equations. The linear differential equation with a constant coefficient solution can be obtained from the given initial conditions. The forms of an appropriate block diagram are represented by the transforms provided. The main procedure in the evaluation of an automatic control system for the selection of Laplace transforms is less suitable for the algorithm that looks quite complex. In this way do not use direct non-Transform scheme and equation involved is as below, the dynamic equation above can be expressed in a form of transfer function. The derivation from above equations of the two inputs, F_a and W and Transfer functions $G_1(s)$ and $G_2(s)$ of output, $x_1 - x_2$, are as follows:

$$\begin{bmatrix} (m_1s^2 + c_1s + k_1) & -(c_1s + k_1) \\ -(c_1s + k_1) & m_2s^2 + (c_1 + c_2)s + (k_1 + k_2) \end{bmatrix} * \begin{bmatrix} X_1(s) \\ X_2(s) \end{bmatrix} = \begin{bmatrix} F_a(s) \\ (c_2s + k_2)W(s) - F_a(s) \end{bmatrix} \quad (3)$$

$$\Delta = \det[M] = (m_1s^2 + c_1s + k_1) * (m_2s^2 + (c_1 + c_2)s + (k_1 + k_2)) - (c_1s + k_1)^2 \quad (4)$$

Next, the input $F_a(s)$ and $W(s)$ is multiplied with the right hand side inverse of the matrix A as follows:

$$\begin{bmatrix} X_1(s) \\ X_2(s) \end{bmatrix} = \frac{1}{\Delta} * \begin{bmatrix} m_2s^2 + b_2s + k_2 & c_1c_2s^2 + (c_1k_2 + c_1k_1)s + k_1k_2 \\ -m_1s^2 & m_1c_2s^3 + (m_1k_2 + c_1c_2)s^2 + (c_1k_2 + c_1k_1)s + k_1k_2 \end{bmatrix} * \begin{bmatrix} F_a(s) \\ W(s) \end{bmatrix} \quad (5)$$

The input considers as $F_a(s)$ only, and $W(s) = 0$. As the result the transfer functions $G_1(s)$ as the following:

$$G_1(s) = \frac{X_1(s) - X_2(s)}{F_a(s)} = \frac{(m_1 + m_2)s^2 + c_2s + k_2}{\Delta} \quad (6)$$

If the input is considered as $W(s)$ only, and $F_a(s) = 0$. Thus, the transfer functions $G_2(s)$ as the following equation:

$$G_2(s) = \frac{X_1(s) - X_2(s)}{W(s)} = \frac{-m_1c_2s^3 - m_1k_2}{\Delta} \quad (7)$$

The input of Transfer Function equation (6) and (7) into Matlab and the standard transfer function $G_1(s)$ and $G_2(s)$ is as follows:

$$G_1(s) = \frac{\text{nump}}{\text{denp}} \quad G_2(s) = \frac{\text{numS}}{\text{dens}} \quad (8)$$

The second reason is that the PID controller has less complexity thus fulfilling the design controller requirement for the Malaysian quarter car model. The schematic diagram of the close-loop controller system is shown in figure 5:

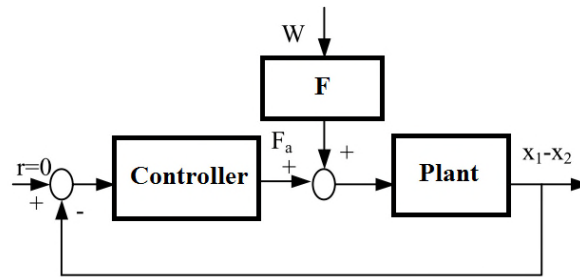

Figure 5. Diagram of the Closed-loop system.

4. Basic method of the semi-active suspension control

Figure 6 shows the complete system incorporating the application of the PID controller to the passive quarter car Proton Preve suspension system. The mathematical model approach for the quarter car suspension system is developed using the Matlab *Simulink* application.

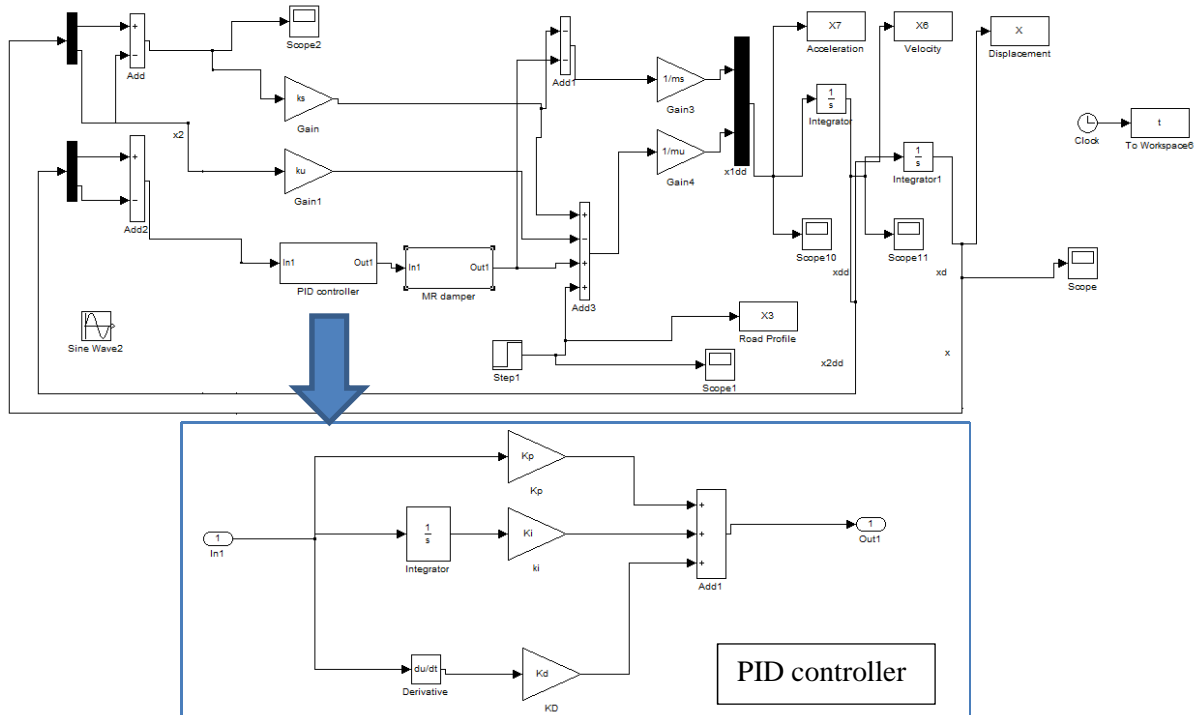

Figure 6. Two degree of freedom quarter car model with PID controller designed in the Matlab and Simulink.

5. Validating of the MR damper model with PID control

Simulation is performed in Matlab-Simulink to acquire the legitimacy of non-parametric information that is used on the MR damper. A road profile (input signal) is tested in this research. Only step profiles are tested for the simulation work as shown in figure 7. This step profile has 0.03m height which is similar for the experiment test. Each simulation produced different types of interesting results depending on K_P, K_I and K_D values. The basic parameters K_P, K_I and K_D are chosen by the trial and error method. Although tuning the PID controller is challenging, the performance of the quarter car system slightly increases.

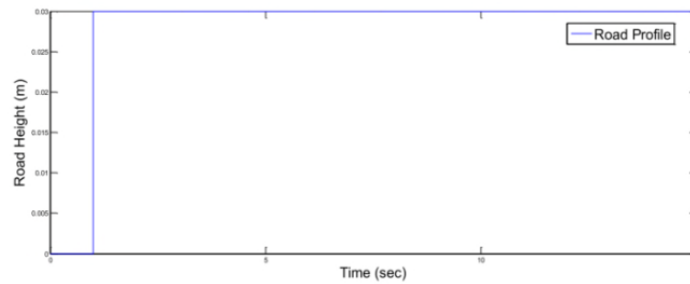

Figure 7. Road profile 3cm step.

The effectiveness of MR damper using PID controller in reducing time taken to isolate the resultant motion into an equilibrium position are shown in Figure 8 until Figure 13. The result of the conventional system is far from pleased in isolating vibration. It exceeds 15 seconds of MR damper integrated with the PID controller time taken to completely absorb. It follows that the PID model can reduce the oscillation as early as 3 seconds up to 10 seconds. However, this depends on the parameters i.e K_P , K_I and K_D . It is necessary to establish the optimum parameter of PID before manipulating electrical current level to fully verify the effectiveness of the system. Referring to Figure 8 to Figure 13, value of K_P varies from 0.1 to 0.7 with an increment of 0.1. As seen from figures, the oscillation is reduced to 0.015 m and 0.01 m from 0.025 m.

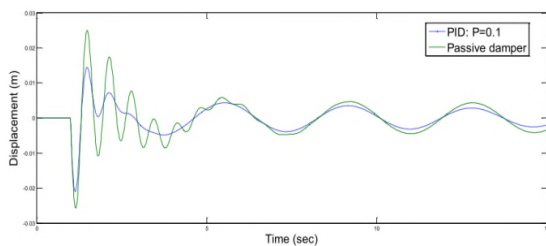

Figure 8. Sprung mass displacement vs time, (PID: P=0.1 and Passive damper).

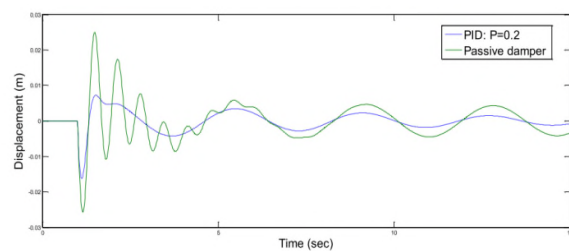

Figure 9. Sprung mass displacement vs time, (PID: P=0.2 and Passive damper).

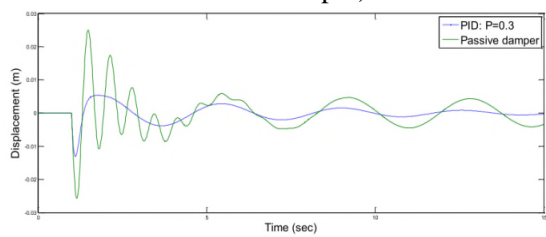

Figure 10. Sprung mass displacement vs time, (PID: P=0.3 and Passive damper).

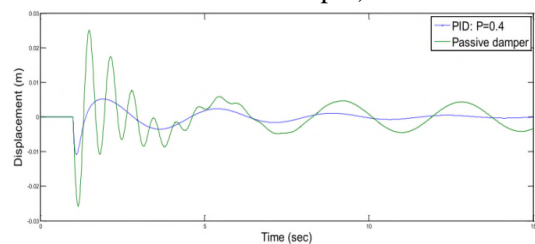

Figure 11. Sprung mass displacement vs time, (PID: P=0.4 and Passive damper).

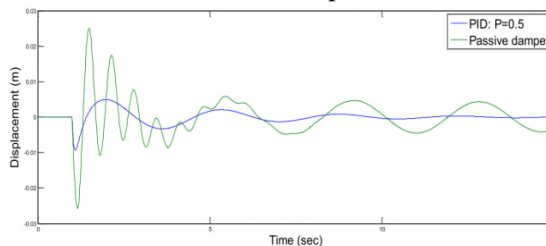

Figure 12. Sprung mass displacement vs time, (PID: P=0.5 and Passive damper).

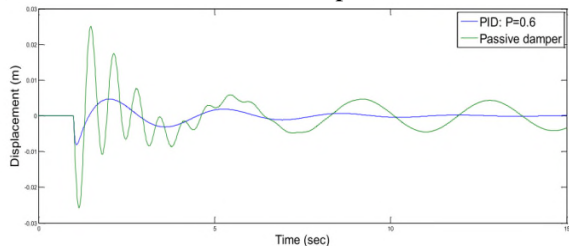

Figure 13. Sprung mass displacement vs time, (PID: P=0.6 and Passive damper).

Although the oscillation becomes lower as the value of K_p increases and the percent of the overshoot shown by these figures is still considerably high enough to give unsatisfactory time settling. These figures illustrate the incapability of the system to give the best performance if only the value of K_p alone is manipulated.

6. Conclusion

Research has been carried out, starting with the designing of the algorithm and physical model based on the quarter car model. The MR damper system is built with the PID controller in Matlab and Simulink. The prototype of MR suspension system is designed following the specifications of PROTON Preve. At the end, this system managed to provide good feedback to the suspension system by tuning in K_p , K_i and K_d . The correlation demonstrates the ability of the MR damper that can offer comfort of more than 60% for the driver and passenger. By looking at these MR and OEM dampers, it can be inferred that the MR model with the PID controller gives the best outcome and it is reasonable for the Malaysian car suspension system. In further research, the dynamic control framework will be adapted into the suspension system.

References

- [1] Zhang Y, Zhan M, Zhao F, Liuc Z W 2015 *J. Franklin Inst.* **352(2)** 485-99.
- [2] Yeh F K, Huang C W and Huang C W 2010 *Adaptive-Sliding-Mode Semi-Active Bicycle Suspension Fork*, International Conference on Instrumentation Publication, Taipei, Taiwan.
- [3] Patil S A, Joshi S G 2014 *Syst. Contr. Eng: Open Access J.* **2(1)** 621-31.
- [4] Gao B Z, Lei Y L, Ge A L, Chen H and Sanada K 2011 *Vehicle Syst. Dyn.: Int. J. Vehicle Mech. Mobil.* **49(5)** 685-701.
- [5] Occhiuzzi A, Spizzuocco M and Serino G 2003 *Smart Mater. Struct.* **12(5)** 703-11.
- [6] Poyner J C 2001 *Innovative Designs for Magneto-Rheological Dampers*, Advanced Vehicle Dynamics Lab, Virginia Polytechnic Institute and State, University, Blacksburg, VA, MS Thesis, August 7, 2001.
- [7] Wu L, Cao Y L and Chen H L 2008 *Hierarchical Model Control of A Motorcycle Semi-Active Suspension with Six Degree-Freedoms*. Proceeding of the 2008 IEEE/ASME International Conference on Advanced Intelligent Mechatronics. July 2-5, 2008, Xi'an China.