

PAPER • OPEN ACCESS

Diatomite carrier for rapid formation of Aerobic Granular Sludge

To cite this article: H F Basri *et al* 2020 *IOP Conf. Ser.: Earth Environ. Sci.* **479** 012028

View the [article online](#) for updates and enhancements.

You may also like

- [Enhanced formation of aerobic granular sludge with yellow earth as nucleating agent in a sequencing batch reactor](#)
Q L He, S L Zhang, Z C Zou et al.
- [Analysis of load variation on chicken slaughterhouse waste water treatment using GAS-SBR](#)
I Septiana, L Siami, T Tazkiaturrizki et al.
- [The feasibility of aerobic granular sludge formation without inoculated sludge](#)
Tao song, Ji li, Xiaolei Zhang et al.



IOP Publishing

ENVIRONMENTAL RESEARCH 2021

A VIRTUAL CONFERENCE
15-19 NOVEMBER

FREE TO ATTEND

REGISTER NOW

Diatomite carrier for rapid formation of Aerobic Granular Sludge

H F Basri^{1*}, A N Anuar^{1*}, Ali Yuzir¹, M H Ab Halim^{1*}

¹Department of Chemical and Environmental Engineering, Malaysia-Japan International Institute of Technology (MJIIT), Universiti Teknologi Malaysia, 54100 Jalan Sultan Yahya Petra, Kuala Lumpur, Malaysia,

*Corresponding author e-mail: hazlamibasri@gmail.com; aznah@utm.my; mohdhakim@utm.my

Abstract. Aerobic granular sludge (AGS) is a spherical compact sludge that has a lot of advantages such as great settling ability, high biomass level, good shock resistance and ability to withstand high organic loading rate (OLR) and toxic pollutants. However, it still has a major weakness that influences the low global reputation of AGS which is long granulation time. Therefore, a support material called diatomite which known for its unique characteristic is used in this study to speed up the granulation process in a pilot sequencing batch reactor (SBR) for domestic wastewater treatment. The AGS was cultivated in a pilot bioreactor for 30 days and measured for its characteristic. The result indicates fast granulation with 18 days of AGS formation period. Moreover, SEM images shows the present of diatomite in the inner part of the mature granules and proved its function as a nucleation agent that accelerate the aggregation process. The developed granules demonstrate excellent strength and settleability with strength (IC: 17.42%), SVI of 68 mL/g SS and settling velocity (114 m h⁻¹) respectively.

1. Introduction

Aerobic granular sludge (AGS) application for wastewater treatment has been extensively studied in the past decade and now become a mature option for implementation. AGS is a spherical compact sludge that is formed through self-immobilisation of microorganisms and floc under aerobic or alternative aerobic–anaerobic conditions [1]. It has a lot of advantages such as great settling ability, high biomass level, good shock resistance and able to withstand high organic loading rate (OLR) and toxic pollutants [2]. Not only that, AGS also cultivated in Sequencing Batch Reactor (SBR) which has less excess sludge production and small footprint [3]. Those significant advantages made AGS is considered to be a prospective biological treatment technology in near future. However, AGS still has a few drawbacks for global recognition in the wastewater treatment application. They are long granulation time [4], long start up time [5], poor stability of aerobic granules [6,7] and occurrence of sludge bulking in a short period of operation time [8]. Among all the mentioned obstacles above, this study is conducted to overcome the problem of long granulation time. In the case of real domestic wastewater that contains low organic loading, it takes a long period (140 days, 150 days, 300 days and 390 days) to develop aerobic granules especially in pilot scale bioreactor [9;10;11;12;13].

In order to facilitate and promote AGS practical application in wastewater treatment, investigation on rapid aerobic granulation have been deeply executed. Most of the research on rapid granulation in the last decade had shown there are few factors that influence the AGS rapid formation such as



manipulation of organic loading rate (OLR), [4], inoculation of sludge [14], influent feeding alkalinity and reactor pH, [6] and addition of a support material for adsorbing microorganisms [5]. Lately, the addition of support material such as diatomite, zeolite, maifanite, magnetic nanoparticles and powdered activated carbon have emerged as an efficient coagulation aid for water and wastewater treatment. According to Chen et al [15], the support material plays a role as a “home” for microorganism. Due to its porous characteristic, there are a lot of space for bacterial growth and this will attract the microbes to attach on the support material [16]. Importantly, this combination of microbes and support material act as a point of nucleation in the development of AGS. By having this nucleation process, it will lead to the acceleration of granular formation.

Diatomite, one type of support material has draws attention among researcher for the past few years. Diatomite is a friable light coloured sedimentary rock formed from naturally occurring fossilized remains of diatoms. It is made up of the shells of single diatoms and readily crumbles into fine powder [17]. In general, what makes diatomite interesting is it have high quality, can be bought at low cost, resourceful and prove to achieve high adsorption performance [17]. In biogranulation perspective, diatomite has a unique characteristic that makes it relevant to enhance the formation of AGS. It has porous structure and large surface area which allows them to capture the suspended microbes quickly [18]. Not only that, diatomite also has high adsorption of organic matter, known as the food of microbes [19]. This will help the microorganism to grow and initiate aggregation. In addition, diatomite also increases microbial diversity which is an important factor for the formation of AGS [20]. Those characteristic made diatomite become a demand support material for wastewater treatment. Therefore, diatomite is used in this study to speed up the granulation process in a pilot SBR to treat domestic wastewater.

The aim of this study is to determine the effect of diatomite on the formation of aerobic granules in a pilot scale bioreactor with real domestic wastewater as the substrate. The physical performance and morphological characteristic of the developed granules with diatomite was highlighted in this study. Importantly, the granulation period was a major element for this research as it shows the capability of diatomite in boosting the formation of AGS. Notably, granulation rate measurement throughout the experiment was a fundamental evaluation for rapid AGS formation. For the record, this research is the first attempt that focusing on the application of diatomite for rapid granulation in pilot scale bioreactor.

2. Materials and methods

2.1 Pilot SBR Bioreactor set-up

A cylindrical column SBR bioreactor (internal diameter of 172 mm with a total height of 650 cm) consisting of a working volume of 15 L was used in this study (figure 1). Then, 7.5 L (50% working volume) of activated sludge from the Indahwater Bonus SBR treatment plant was added into the bioreactor during the start-up period as inoculums. Additionally, 7.5g of diatomite was introduced into the system and mixed with the sludge. A feeding, discharge and an air pump with the setting time for each phase in the bioreactor was controlled with pre-programmed digital timers. The bioreactor was operated through successive cycles of 3 h. Each cycle consisted of a 60 min-influent feeding phase from the bottom of the bioreactor without stirring, 110 min-aeration phase, 5 min-settling periods and 5 min-effluent discharge period. Real domestic wastewater was fed into the system and discharged by a set of two peristaltic pumps. Furthermore, the bioreactor was aerated with an air pump that was operated at a constant flow rate of $0.7 \text{ m}^3 \text{ h}^{-1}$ (2.5 cm s^{-1} superficial air flow velocity). A fine bubble diffuser located at the bottom of the bioreactor was used for aeration to produce air bubbles. The effluent withdrawal point was positioned at the middle height of the column, operating at volumetric exchange ratio (VER) of 50 % per cycle. The bioreactor was scheduled to run for 30 days without excess sludge discharge, thus the effluent was the only passage for biomass waste to be transported. The working temperature of the bioreactor was kept at $27 \pm 1 \text{ }^\circ\text{C}$ without controlling the dissolved oxygen and pH level. Figure 1 shows the schematic diagram of operational reactor setup.

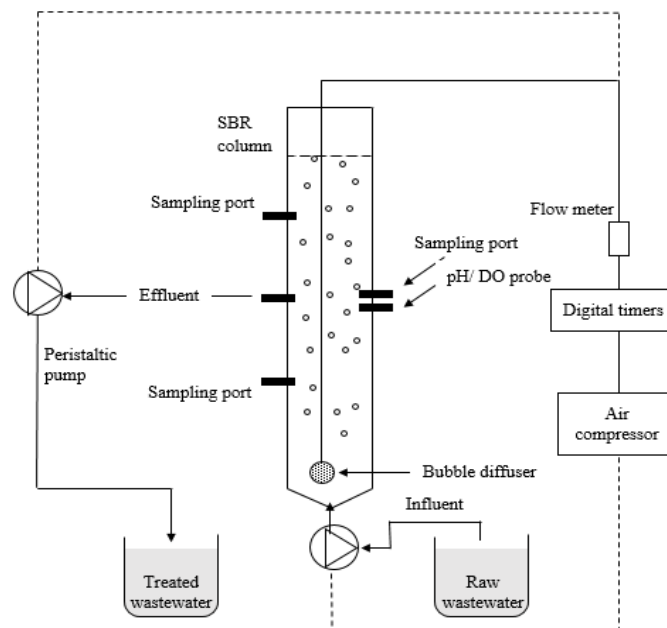

Figure 1. Schematic diagram of operational reactor setup.

2.2 Diatomite characteristic

Diatomite is a pale colored and soft lightweight sedimentary rock that is formed from the fossil remains of diatoms. It is abundant in many areas of the world and can be easily obtain with a cheap price. The diatomite used in this study was obtained from YunNan QingZhong Science Tech Co. Ltd (Beijing, China). Diatomite is a fine-porous structure, very small and light, that make it has low thermal conductivity and density. Furthermore, diatomite also well known for its high surface area and relatively high adsorption ability having active acid surface sites chemistry. The surface of diatomite has unique properties in relation to the presence of water such as hydrophobicity, high solubility, negatively charge, low pH (acidity) and excellent ion exchange mechanism [21]. These physical and chemical characteristic enhance diatomite application for various purposes including wastewater treatment industry.

2.3 Analytical methods

The sludge and wastewater (influent and effluent) were an important elements related to the characterization of developed AGS and removal performance. Each of them need to be analysed and measured using standard analytical methods. For monitoring the biomass concentration, MLSS and MLVSS, it was measured according to the Standard Methods for the Examination of Water and Wastewater [22]. The sludge volume index (SVI), granulation rate and average particle size measurements were carried out using the method explained by de Kreuk et al. [23] and Long et al. [14] for granules physical characteristic analysis. Other parameter such as granular strength was also determined, by measuring the integrity coefficient [3]. In the case of AGS characterization, the morphology and structure of the developed AGS was examined periodically by using a stereo microscope equipped with digital image analyser (Olympus SXZ7). While, the microstructure compositions within the cultivated granules was observed using scanning electron microscope (SEM) (JSM-J800F, JEOL, Japan). The granules were prepared according to Ab Halim [3] before platinum sputter coating for 60 s (Q150R S, Quorum, UK) was applied as a pre-treatment procedure for SEM image.

3. Result and discussion

3.1 Formation mechanism of aerobic granular sludge by using diatomite and morphological observation.

The findings of this study on the effect of diatomite towards granule formation and performance was summarized in Figure 3 to 5. Meanwhile, the microscopic images of the granules morphological transformation across 30 days of the experiment was shown in Figure 2. The experiments begin with the fresh activated sludge (Fig 2a) that appeared as an irregular and loose-structure morphology with numerous filamentous bacteria growing on the surface. At this stage there were no clear granules that been observed as the average size was less than 0.3 mm. The sludge also has low settling ability with 129 mL/g SS which result in long settling time during the early phase of the treatment. The bioreactor was operated at day 1 with MLSS and MLVSS of 7000 mg/L and 4600 mg/L respectively. After just 4 days, a minority of small granules started to show up and gradually increased. The size of the sludge during this period was in the range of 0.1 to 0.5mm. At day 6, due to shorter settling time strategy, the loose and fluffy shape sludge was gradually washed out from the pilot bioreactor to ensure the good settleability performing sludge retained and continue to developed in the system. Surprisingly, after 10 days of operation, it was recorded that 70% of the sludge have become granules (size > 0.3 mm). This rapid transition of seed sludge to granules indicate the effect of diatomite functioning as a carrier and nucleation agent for granulation process. According to Sarma et al. [24], the first phase of AGS formation (cell to cell interaction), normally takes a long period before entering the second phase (micro aggregate formation). This is where diatomite plays a crucial role by acting as a point of nucleation to initiate aggregation. With the achievement of initial aggregation, the subsequent granulations are easy to proceed [15]. During 10th day observation of microscopic images (figure 2b), the small, thin and regular shape granules can clearly be seen. As the granules developed inside the bioreactor increased, the performance of the system towards the settleability and the removal of organics and nutrients also became more efficient. Afterward, many aerobic granules with solid and smooth surface was detected in the system (Figure 2c) and the granulation was achieved at day 20. According to Long et al. [7], the aerobic granulation could be considered successful when the granulation rate firstly accounted for 90% of the total sludge in the bioreactor system. In this study, 92% of granulation rate was recorded at day 20. Starting from this day onwards, the performance of AGS was stable and maintained until the last day of experiment. Figure 2c shows the images of the granules at day 30. The granules were obviously becoming bigger and compact with the highest average diameter of 2.5 ± 1 mm. The settleability performance of the AGS at the end of this experiment was excellent as the AGS recorded SVI (68 mL/g SS). Across 30 days of the experiment, the MLSS and MLVSS value was increased to 8800 mg/L and 6600 mg/L. The biomass value demonstrated large amount of biomass was kept to ensure stable performance of the treatment.

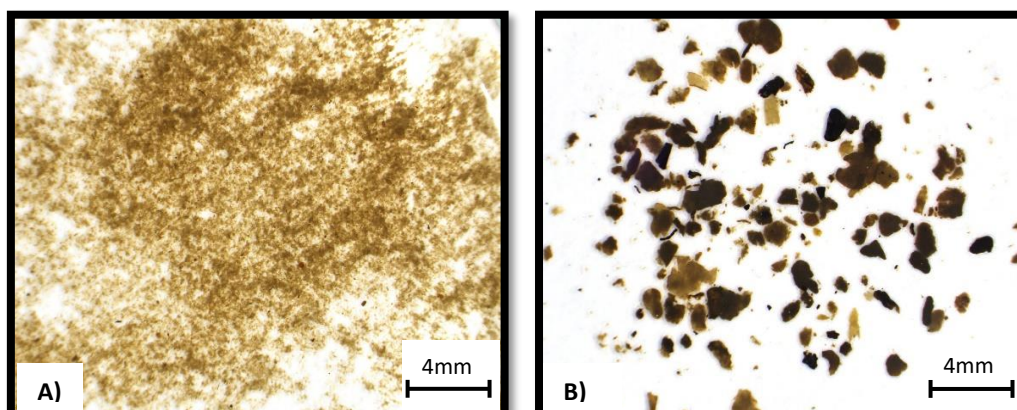

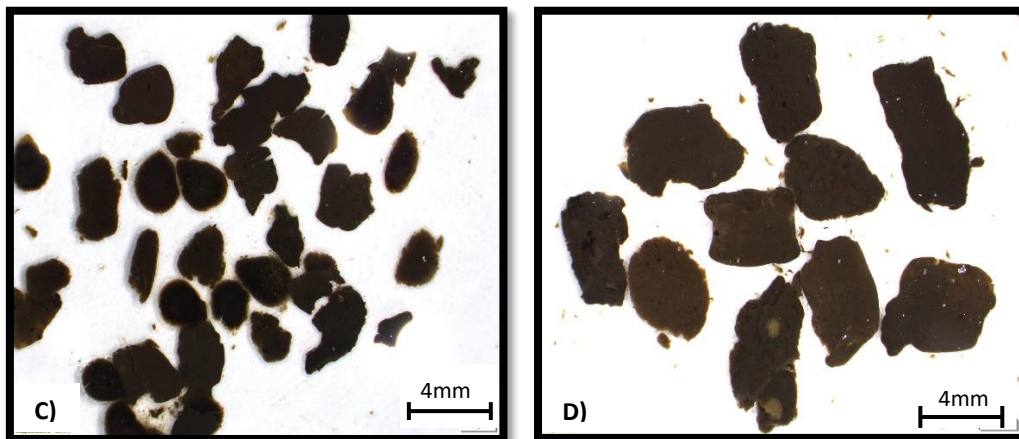

Figure 2. Microscopic images of the transformation of seed sludge to mature AGS in 30 days period

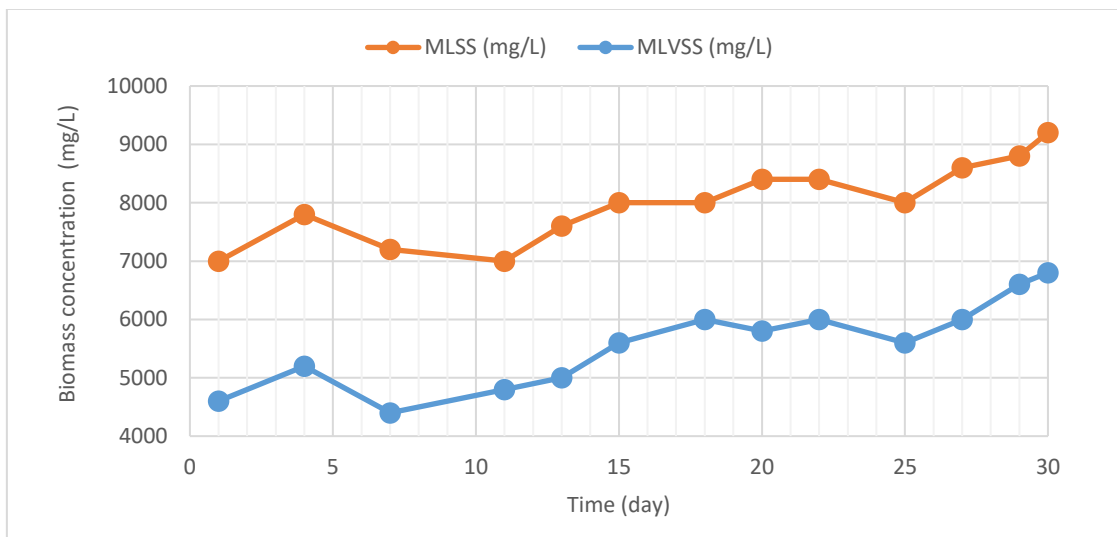

Figure 3. MLSS and MLVSS concentrations of the system during 30 days of the experiment.

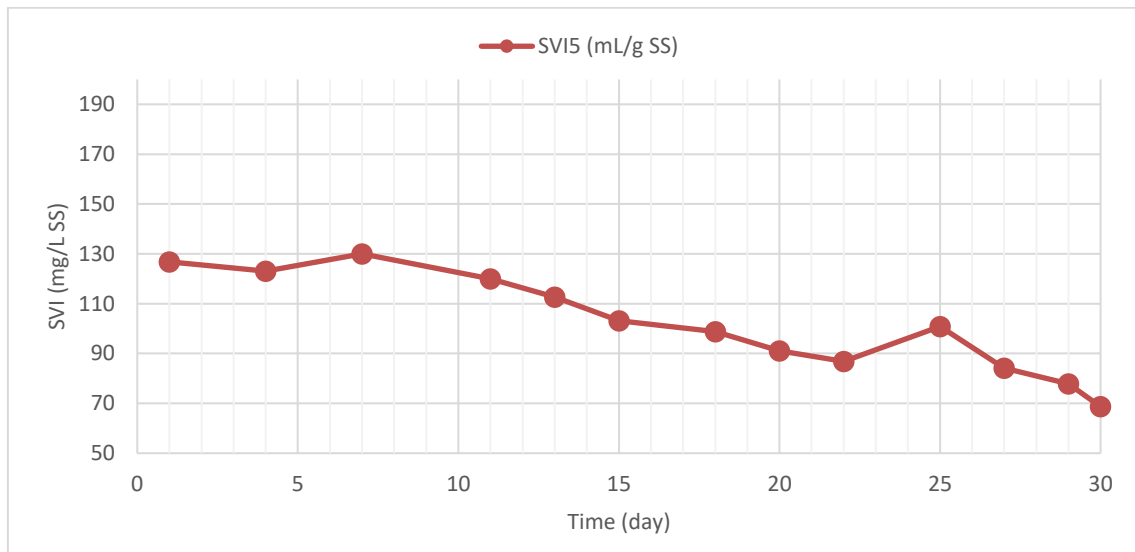

Figure 4. Sludge Volume Index (SVI) and settling velocity of the granules during 30 days of the experiment.

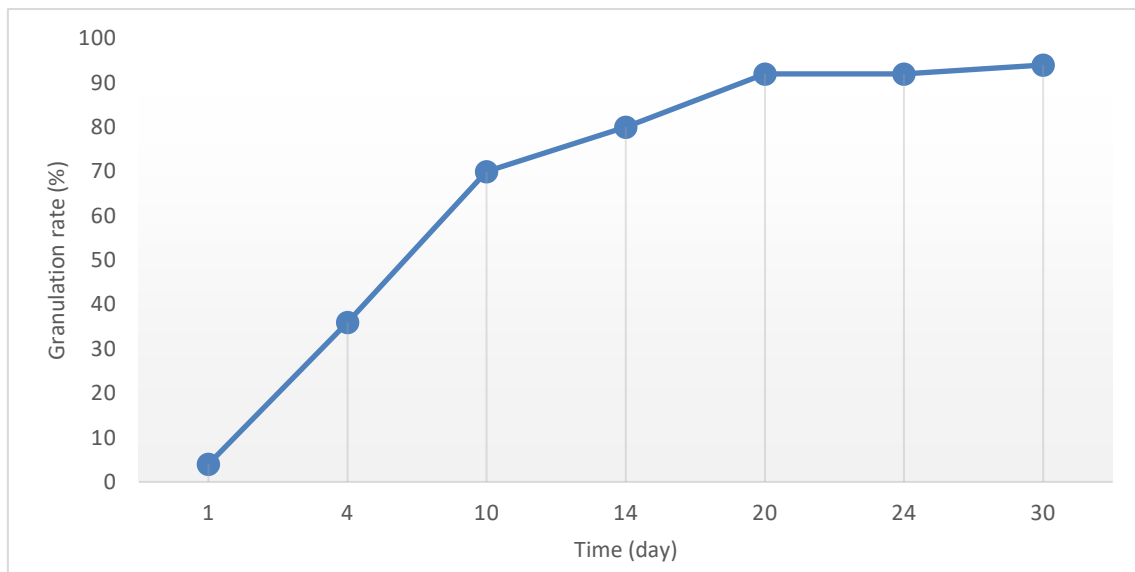

Figure 5. Granulation rate of the AGS throughout 30 days of the experiment.

Later, the inner and outer layer structures of 4mm (diameter) aerobic granules was visually examine via SEM. The surface of the developed granules was closely observed as shown in Figure 6. The outer layer structure of the granules displayed a porous structure with a lot of cavity (figure 6a). The cavities were functioning as a passage for the transportation of nutrients, oxygen and substrate to the inner core of granules [25]. Another elements that clearly seen throughout the granules surface was Extracellular Polysaccharide Substances (EPS) as illustrated in figure 6b. According to Chen et al. [26], EPS are complex mixture of polymers that normally present on the microbial cell surface, plays a crucial roles in facilitating AGS formation by keeping the microbial aggregates bind together. The major components

of EPS are Polysaccharides (PS) and proteins (PN), mainly involve in altering the physicochemical properties of sludge in biological wastewater [27]. Apart from that, a closer observation towards the inner part of the granules discovered numbers of diatomite was present at different location. As shown in figure 6c, illustrating the images of single diatomite, it was noticed that the surface of diatomite was enclosed and tightly bonded with microbial cells and EPS. This phenomenon proved the function of diatomite as a carrier and point of nucleation during the formation of AGS. Similar observation by Chen et al. [15] reported the diatomite was found in the center of the granular sludge and act as a substrate for the microbes. With more than one diatomite was discovered in the 4 mm diameter granules, it was believed that each diatomite and microbial cells undergoing aggregation process to formed one small aggregates. Then, it was bonded by EPS together with other aggregates filled with diatomite as the nuclei, to formed a larger granules. Therefore, the AGS formation was presumably catalyst by the existence of diatomite.

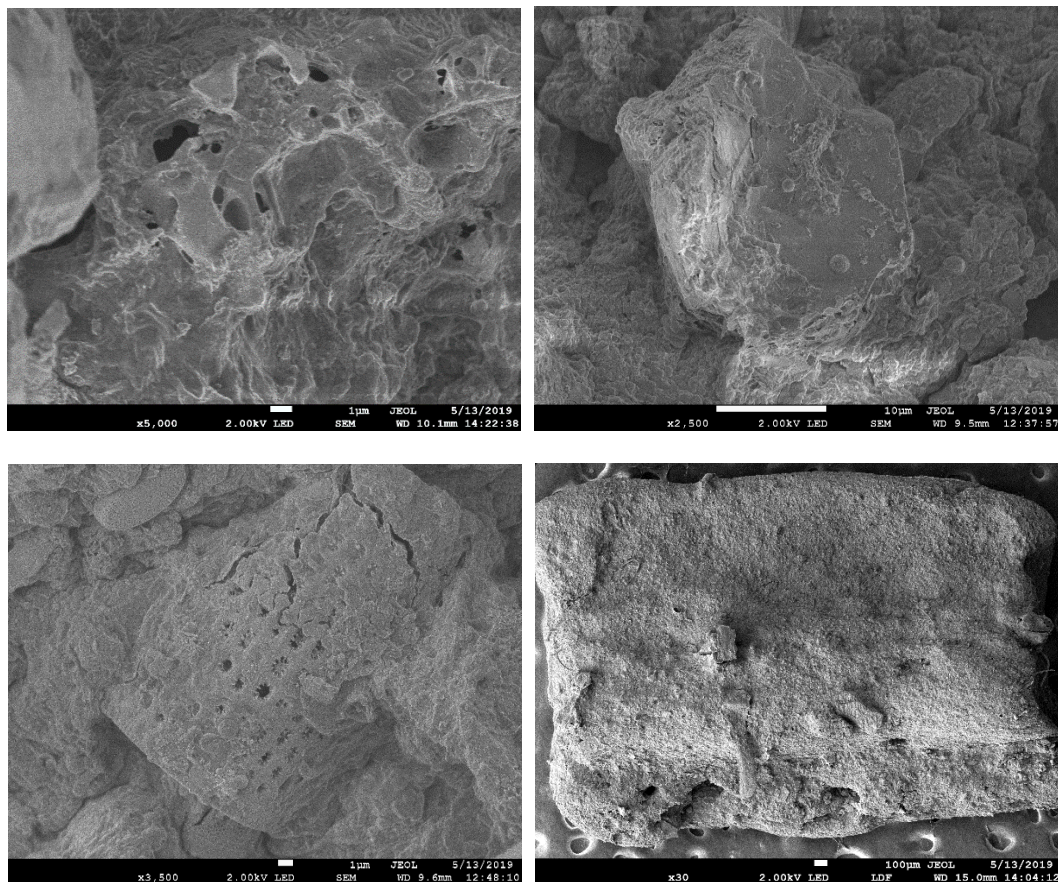

Figure 6. SEM images of the surface and inner part of the granules

3.2 Strength and settling velocity performance of AGS

Along with the transformation of sludge to become AGS, the characteristic of the sludge also experiences dynamic change across 30 days of the experiment. The AGS characteristic's related parameter that being measured are settling ability and strength of the granules as shown in figure 7 and figure 8. Primarily, AGS is widely known for its compact physical attributes that make it settles in a short period of time. According to Othman [28], the typical settling velocity of aerobic granules was in the range of 25 to 70 mh^{-1} while for activated sludge floc was 7 to 10 mh^{-1} . Furthermore, the other parameter which is granules strength was described as the capability of the AGS to withstand shear. The

strength was measured according to Integrity coefficient (IC) percentage ratio. As mentioned by Ibrahim et al. [29], aerobic granules with IC ratio less than 20%, are considered as an excellent strength granule with compact structure. Importantly, both of the parameter (strength and settling velocity) were strongly correlated in demonstrating the ability and performance of granules in the bioreactor system. In this study, the seed sludge recorded slow settling velocity (5.7 m h^{-1}) and high IC percentage (49%) indicating poor strength and loose structure of the sludge during day 0. Afterward, as rapid formation of AGS takes place, the strength of the granules increased resulting in significant improvement of settling velocity. In accordance with Ibrahim et al. [29], the phenomenon of AGS development, elevates its physical strength which transformed into a denser granules and results in higher settling velocity. Eventually, at the end of experiment after 30 days' period, the granules were reported to achieve desired strength (17.42%) below 20%, and fast settling velocity of 114 m h^{-1} .

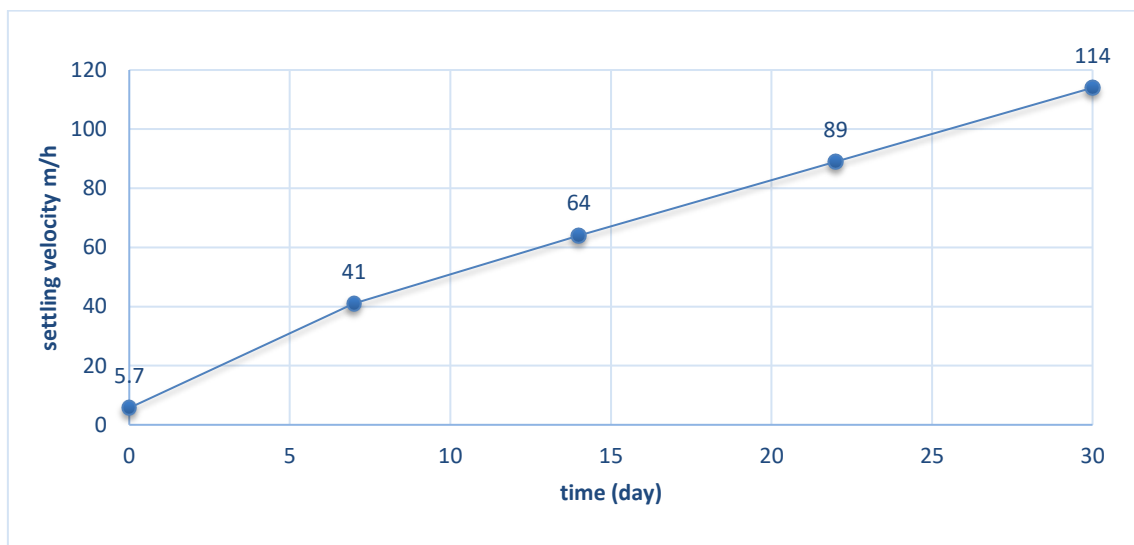

Figure 7. Settling velocity of AGS throughout 30 days of experiment

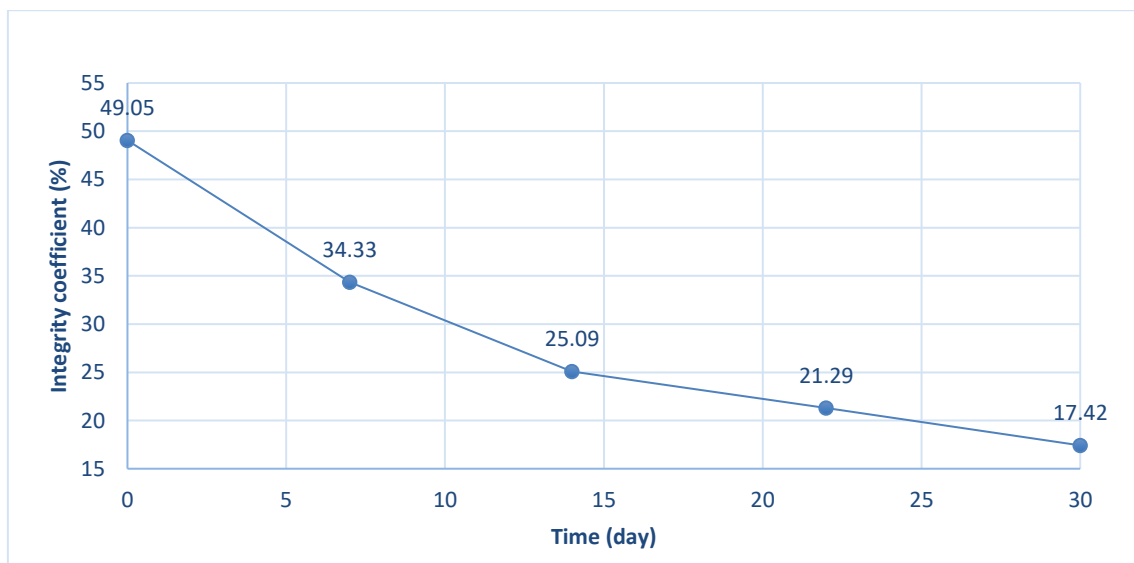

Figure 8. Integrity coefficient (strength) of AGS throughout 30 days of experiment

4. Conclusions

In conclusion, aerobic granules were successfully cultivated using diatomite in a pilot scale bioreactor within 18 days. It was proven that the diatomite could enhance the formation of granules by acting as a nucleation point which lead to a faster aggregation process. Moreover, the important roles of diatomite in the formation of AGS was also recognised when the SEM result indicates there are numbers of diatomite presence in the inner part of the granules. There was a clear morphological difference between seed sludge and the developed granules after the microscopic observation at the end of the experiment. The developed AGS demonstrates excellent characteristic in terms of strength and settleability. The strength of the granules was 17.42% IC, while the SVI and settling velocity were 68 mL/g SS 114 mh⁻¹ respectively. Lastly, the results from this pilot-scale study of AGS using diatomite are expected to contribute for full-scale application of rapid biogranulation technology.

Acknowledgments

The authors wished to thank the Ministry of Education Malaysia (Higher Education) and Universiti Teknologi Malaysia for the financial support of this prototype development research grant scheme (Grant No: R.K 130000.7843.4L682). The authors would like to also express gratitude to the Malaysia-Japan International Institute of Technology for the scholarship granted to the authors.

References

- [1] Sarma, S. J., and Tay, J. H. (2018). Aerobic granulation for future wastewater treatment technology challenges ahead. *Environmental Science Water Research & Technology*, 4
- [2] Xia, J., Ye, L., Ren, H., and Zhang, X. X. (2018). Microbial community structure and function in aerobic granular sludge. *Applied microbiology and biotechnology*, 102(9), 3967-3979.
- [3] Ab Halim. (2018). Development of Aerobic Granules in Sequencing Batch Reactor System for treating High Temperature Domestic Wastewater. Doctor of Philosophy, Universiti Teknologi Malaysia, Skudai
- [4] Hamza, R. A., Iorhemen, O. T., Zaghoul, M. S., and Tay, J. H. (2018). Rapid formation and characterization of aerobic granules in pilot-scale sequential batch reactor for high-strength organic wastewater treatment. *Journal of water process engineering*, 22, 27-33.
- [5] Liang, X. Y., Gao, B. Y., and Ni, S. Q. (2017). Effects of magnetic nanoparticles on aerobic granulation process. *Bioresource technology*, 227, 44-49.
- [6] Rezasoltani, S., Shayegan, J., and Jalali, S. (2015). Effect of pH on aerobic granulation and treatment performance in sequencing batch reactors. *Chemical Engineering & Technology*, 38(5), 851-858.
- [7] Long, B., Yang, C.Z., Pu, W.H., Yang, J.K., Jiang, G.S., Li, C.Y., Liu, F.B., Dan, J.F., Zhang, J. and Zhang, L., (2016). Rapid cultivation of aerobic granule for the treatment of solvent recovery raffinate in a bench scale sequencing batch reactor. *Separation and Purification Technology*, 160, 1-10
- [8] Jiang, Y., Shang, Y., Wang, H., and Yang, K. (2016). Rapid formation and pollutant removal ability of aerobic granules in a sequencing batch airlift reactor at low temperature. *Environmental technology*, 37(23), 3078-3085.
- [9] Wagner, J. and da Costa, R.H.R., 2013. Aerobic granulation in a sequencing batch reactor using real domestic wastewater. *Journal of environmental engineering*, 139(11), 1391-1396.

- [10] Ni, B. J., Xie, W. M., Liu, S. G., Yu, H. Q., Wang, Y. Z., Wang, G., & Dai, X. L. (2009). Granulation of activated sludge in a pilot-scale sequencing batch reactor for the treatment of low-strength municipal wastewater. *Water Research*, 43(3), 751-761.
- [11] Pronk, M., De Kreuk, M. K., De Bruin, B., Kamminga, P., Kleerebezem, R. V., & Van Loosdrecht, M. C. M. (2015). Full scale performance of the aerobic granular sludge process for sewage treatment. *Water Research*, 84, 207-217.
- [12] Giesen, A., de Bruin, L.M.M., Niermans, R.P., van der Roest, H.F., 2013. Advancements in the application of aerobic granular biomass technology for sustainable treatment of wastewater. *Water Pract. Technol.* 8 (1), 47e54
- [13] Van der Roest, H. F., De Bruin, L. M. M., Gademan, G., & Coelho, F. (2011). Towards sustainable waste water treatment with Dutch Nereda® technology. *Water Practice and Technology*, 6(3).
- [14] Long, B., Yang, C.Z., Pu, W.H., Yang, J.K., Jiang, G.S., Dan, J.F., Li, C.Y. and Liu, F.B., (2014). Rapid cultivation of aerobic granular sludge in a pilot scale sequencing batch reactor. *Bioresource technology*, 166, 57-63.
- [15] Chen, C., Liang, J., Yoza, B. A., Li, Q. X., Zhan, Y., and Wang, Q. (2017). Evaluation of an up-flow anaerobic sludge bed (UASB) reactor containing diatomite and maifanite for the improved treatment of petroleum wastewater. *Bioresource technology*, 243, 620-627.
- [16] Li, L., and Visvanathan, C. (2017). Membrane technology for surface water treatment: advancement from microfiltration to membrane bioreactor. *Reviews in Environmental Science and Bio/Technology*, 16(4), 737-760.
- [17] Xu, K., Liu, Y., Wang, Y., Wang, T., Wang, H., Liang, X., Lu, C., Tan, Y., Liu, X. and Wang, P., (2018). A Novel Wastewater Treating Material: Cationic Poly Acrylamide/Diatomite Composite Flocculant. *Journal of Polymers and the Environment*, pp.1-9.
- [18] Gu, Q. Y., Liu, X. Y., & Wang, Z. N. (2017). Enhanced Performance of Sulfate Reducing Bacteria (SRB) Granules Process by Using Diatomite as Functional Carrier Material. In *Key Engineering Materials* (Vol. 730, pp. 206-211). Trans Tech Publications.
- [19] Zhang, W., Jun, M. A., Shidong, Y. A. N. G., Zhang, T., and Yongfeng, L. I. (2006). Pretreatment of coal gasification wastewater by acidification demulsion. *Chinese Journal of Chemical Engineering*, 14(3), 398-401.
- [20] Yang, G. F., Feng, L. J., Wang, S. F., Yang, Q., Xu, X. Y., and Zhu, L. (2015). Performance and enhanced mechanism of a novel bio-diatomite biofilm pretreatment process treating polluted raw water. *Bioresource technology*, 191, 271-280.
- [21] Ediz, N., Bentli, İ., and Tatar, İ. (2010). Improvement in filtration characteristics of diatomite by calcination. *International Journal of Mineral Processing*, 94(3-4), 129-134.
- [22] American Public Health Association (APHA). (2012). *Standard Method for the Examination of Water and Wastewater* (22nd Ed). Washington: American Public Health Association (APHA).
- [23] De Kreuk M.K (2007). Aerobic granular sludge. State of the art, *Water Science and Technology*, 55 (8-9), 75 -81
- [24] Sarma, S. J., Tay, J. H., & Chu, A. (2017). Finding knowledge gaps in aerobic granulation technology. *Trends in biotechnology*, 35(1), 66-78.
- [25] Ab Halim, M.H., Anuar, A.N., Azmi, S.I., Jamal, N.S.A., Wahab, N.A., Ujang, Z., Shraim, A. and Bob, M.M., (2015). Aerobic sludge granulation at high temperatures for domestic wastewater treatment. *Bioresource technology*, 185, 445-449.
- [26] Chen, C., Ming, J., Yoza, B.A., Liang, J., Li, Q.X., Guo, H., Liu, Z., Deng, J. and Wang, Q., 2019. Characterization of aerobic granular sludge used for the treatment of petroleum wastewater. *Bioresource technology*, 271, 353-359.

- [27] Wei, D., Wang, B., Ngo, H.H., Guo, W., Han, F., Wang, X., Du, B. and Wei, Q., (2015). Role of extracellular polymeric substances in biosorption of dye wastewater using aerobic granular sludge. *Bioresource technology*, 185, 14-20.
- [28] Othman, I. (2017). *Aerobic Granular Sludge from Different Cycle Time for Livestock Wastewater Treatment*. Doctor of Philosophy, Universiti Teknologi Malaysia, Skudai
- [29] Ibrahim, Z., Amin, M. F. M., Yahya, A., Aris, A., and Muda, K. (2010). Characteristics of developed granules containing selected decolourising bacteria for the degradation of textile wastewater. *Water Science and Technology*, 61(5), 1279-1288.