

PAPER • OPEN ACCESS

Experimental study on composite connection with double lipped C- Sections

To cite this article: Muhammad Firdaus *et al* 2020 *IOP Conf. Ser.: Mater. Sci. Eng.* **849** 012067

View the [article online](#) for updates and enhancements.

You may also like

- [Spin injection into multilayer graphene from highly spin-polarized \$\text{Co}_2\text{FeSi}\$ Heusler alloy](#)
Takehiro Yamaguchi, Rai Moriya, Soichiro Oki et al.
- [Uniaxial anisotropy, intrinsic and extrinsic damping in \$\text{Co}_2\text{FeSi}\$ Heusler alloy thin films](#)
Binoy Krishna Hazra, S N Kaul, S Srinath et al.
- [Chronic fatigue syndrome and impaired peripheral pulse characteristics on orthostasis—a new potential diagnostic biomarker](#)
John Allen, Alan Murray, Costanzo Di Maria et al.



The Electrochemical Society
Advancing solid state & electrochemical science & technology

241st ECS Meeting

May 29 – June 2, 2022 Vancouver • BC • Canada
Abstract submission deadline: Dec 3, 2021

Connect. Engage. Champion. Empower. Accelerate.
We move science forward



Submit your abstract



Experimental study on composite connection with double lipped C- Sections

Muhammad Firdaus¹, Anis Saggaff², Mahmood Md Tahir³, Shek Poi Ngian³, Tan Cher Siang³, K M Aminuddin² and Musab Nimir Ali Salih³

¹Civil Engineering Department, Faculty of Engineering, PGRI University Palembang, 30116, Indonesia.

²Civil Engineering Department, Faculty of Engineering, Universitas Sriwijaya, Inderalaya, 30862, Indonesia.

³UTM Construction Research Centre, Faculty of Engineering, Universiti Teknologi Malaysia, 81310 UTM Johor Bahru, Johor, Malaysia.

Email: firdaus@univpgri-palembang.ac.id

Abstract. The application of Cold-formed steel (CFS) is getting popular in several countries, and this indicates that a good potential of using lightweight materials as an alternative solution to conventional steel. However, there is still a lack of information about joint behavior, particularly composite connections integrated with CFS. This paper presents an isolated joint test of composite joints consisting of concrete slab 100 mm thickness, double lipped channel section used for beam and column, connected by hot-rolled steel gusset plates and bolts. The weakness of the thin plate behavior in the compression zone was reduced by installing the angle stiffener on the web column. Two specimens with the same configuration but with and without seat angle were tested. The experiment results revealed that by the use of seat angle, the moment resistance and stiffness of joints increased with the ratio 1.06 and 1.19, respectively.

1. Introduction

The developments of the construction industry lead to the usage of environmentally friendly materials, fast installation, and easy to implement. These criteria can be met by cold-formed steel (CFS) because it is termite resistant and has the highest strength to weight ratio. Compared to hot-rolled steel, CFS is superior in terms of weight because the thickness usually is less than 3 mm. CFS is made from metallic-coated sheet steel; the fabrication at room temperature allows this material to be formed according to requirements. It is not surprising that CFS can be used for various purposes such as partition walls, channels, roof trusses, frames, beams, and columns. The increasing of the research indicates the opportunities for CFS as alternative materials of hot-rolled steel and wood [1].

The research on CFS as structural elements began since the manufacture of steel profiles with larger dimensions and thicker plates. In-depth studies are no longer limited to the partition walls or roof truss but have been extended to the primary structures such as beam, column, or portal frame. Some of the research was carried out by modifying standard sections or the addition of external elements. Hadjipantelis, Gardner et al. introduced the pre-stressed cold-formed steel beam, the use of pre-stressing cable is to increase load capacity and to reduce deflection of the beam [2]. Dubina, Ungureanu, & Gilia [3] proposed CFS beams of corrugated web, the objective of the research is to improve the buckling stability of the beam and to reduce the use of web stiffeners.



Content from this work may be used under the terms of the [Creative Commons Attribution 3.0 licence](https://creativecommons.org/licenses/by/3.0/). Any further distribution of this work must maintain attribution to the author(s) and the title of the work, journal citation and DOI.

The experimental of CFS composite beams is to find out the possibility of the shear connector without the need for welding work. Salih, Tahir et al. [4] proposed the use of a 12 mm deformed bar as shear connector, Alhajri, Tahir et al. [5] examined the U-shape composite beam by applying M12 bolts. The results of both of these experiments proved that the shear connector provides a high degree of composite action. The finite element analysis of CFS composite beam has been reported by Saggaff et al [6] and Majdi, Hsu, & Zarei [7], they revealed that the research was an innovation and new type of composite system as lightweight section was introduced. The experimental investigation of portal frames composed by double lipped channel back-to-back was conducted by Blum & Rasmussen [8] where the CFS was used for primary elements, such as columns, rafter beams, and knee braces. The results of the research demonstrated that CFS could also be used for large open space areas, however, the research highlights that the structural stability is extremely influenced by the stiffness and strength of the connections between elements.

The research on CFS is also extended in the connection area because it has a direct influence on the overall structural performance. Several studies have discussed the combination of CFS with other joint elements; however, due to the limited information for CFS joints, the analysis is still referred to the design reference for hot-rolled steel based on BS EN 1993 1-8 [9], where the formulations only applicable for thickness ≥ 3 mm. Lee et al [10] have examined the behavior of CFS connections with top-seat flange cleat connection. The research of beam-to-column gusset plate joints has also been studied experimentally and analytically by Tan, Tahir, Shek, & Kueh [11] and Bučmys & Daniūnas [12]. The background of the studies was due to the absence of a design procedure for gusset plate joints. Therefore, Bucmys proposed the stiffness formulation to evaluate the gusset plate connection. It has been proven that EC3 can also be applied to thicknesses less than 4 mm.

The description above shows an effort to reduce the dependence on conventional steel in both composite and non-composite applications. Furthermore, the majority of the concerns are the use of the thinner sections leading to reduced buckling loads. Although it has been proven that the composite system can improve performance, rapid erection, and benefit in cost-effectiveness [12], there is still insufficiency study on the composite beam-to-column connection combined with cold-formed steel.

The aim of this paper is to presents the experimental results of the composite connection of CFS by stiffening the proposed bolted connection with a hot-rolled gusset plate of 6mm thick. Two specimens representing semi-continuous construction have been tested under monotonic loading at structural laboratory of Universiti Teknologi Malaysia. The performance of the joints has been analyzed in terms of moment capacity and rotational stiffness. The failure modes of connection include the region of the concrete slab are also described.

2. Configuration of specimens and procedures of test

2.1. Configuration of specimens

A total of two specimens were carried out where the arrangement of the specimens is shown in **Figure 1** and **Table 1**. The material used for the column and beam is of cold-formed steel of the lipped channel section labeled as isolated joint test (IJT). The dimension of the beam and column of equal size DLC300 (**Figure 2a**). The gusset plate used was 10mm thick cut into haunched shape and bolt hole of 12mm in diameter was drilled for the installation of bolt. The M12 bolts Grade 8.8 with two washers were used as fasteners. As shown in **Figure 2b** and **Table 2**, the distance of bolt hole was arranged in accordance with EC3 [9]. Self-compacted concrete from LAFARGE with design strength of $f_c=40$ Mpa was ready-mix and cast as the concrete slab of 100 mm thickness and 750 mm width connected to the top of beam flange by means of M12 bolts as shear connector where the yield stress was 758 Mpa based on tests conducted by Lawan [13]. The profiled sheeting from Ajiya Peva was used as formwork, and the thickness is 1.0 mm and $f_y=350$ Mpa. The steel deck has an intermediate stiffener in the middle of the bottom flange; thus, it is necessary to install the shear connector away from the stiffener.

Furthermore, in order to avoid punching failure of the rib, the shear connector was placed "off-center" in a favorable location [14], as shown in **Figure 1**. The angle stiffener with L100707 was installed at column web to increase the resistance at compression zone. The anchorage reinforcement bar, 2D12 was

used to prevent the transverse splitting or tensile forces. Anderson's suggested the anchorage arrangement should be installed as close as possible around the column, in order to enable load transfer into the column without cracking on the slab [15].

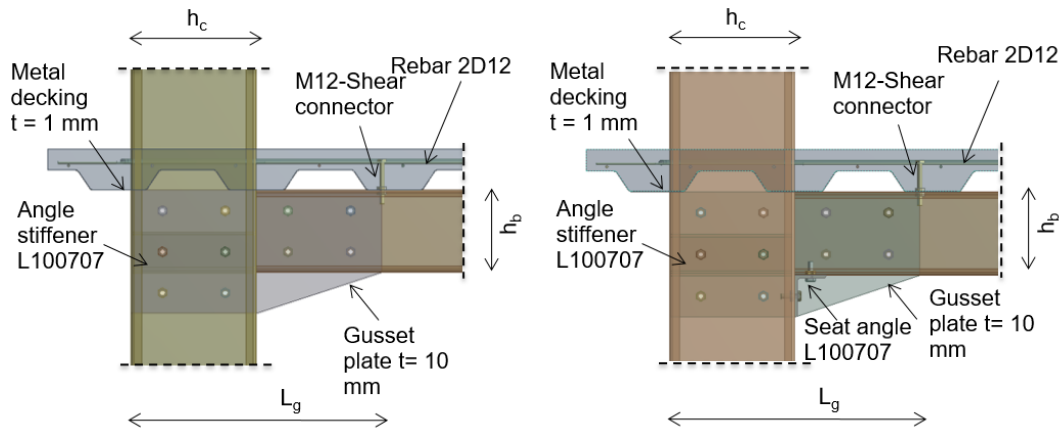

(a) Specimens IJT-03

(b) Specimens IJT-06

Figure 1. Isolated joint test configuration

Table 1. Material size and strength

Test ID	Beam Column	Anchor Reinf.	Gusset Plate	Metal decking	Wire mesh	Angle Stiffener	Seat Angle	Shear Connector
IJT-03	DLC300	2D12	t=10 mm	t=1 mm	A6-200	L100707	-	M12
IJT-06	DLC300	2D12	t=10 mm	t=1 mm	A6-200	L100707	L100707	M12
f_y (Mpa)	545	647	321	350	631	350	350	758
f_u (Mpa)	637	747	465	505	721	505	505	834
Notes	Coupon test	Tension test	Coupon test	S350	Tension test	S350	S350	Lawan (2015)

Table 2. The bolt distance

No	Bg	Lg	e1	e2	p1	p2	p3
		mm	mm	mm	mm	mm	mm
1	450	600	75	75	150	150	150

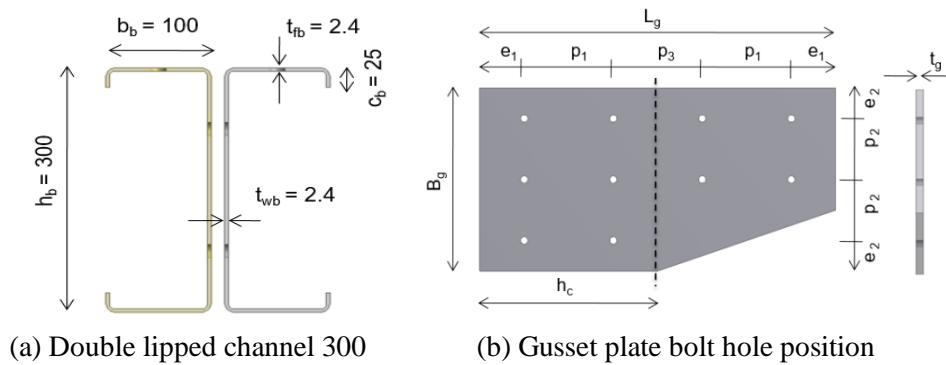

Figure 2 Lipped channel and gusset plate

2.2. Test set up

The test set-up of the Isolated Joint Test (IJT) was prepared for a beam-to-column connection. One end of the beam is connected to the column by the proposed connection. The other end of the beam was loaded with applied load connected to the load cell and hydraulic jack as shown in Figure. 3. The gradual increment of this applied load from this hydraulic was recorded so that a graph of the moment versus rotation can be plotted. The lateral restraint was installed vertically at the beam ends to avoid excessive torsion or deformation. Five LVDTs were used to record linear displacement of the specimen according to the orientation of the instrument. Two inclinometers were installed at the beam and column in order to determine the rotation of the connection in radians. The stress-strain was recorded simultaneously by 5 strain gauges, where SG-1 to SG-4 were placed at beam flange and column web, while SG-5 was attached to anchor reinforcement. The measured data of load cell, LVDTs and strain gauge were recorded automatically by the data logger, except inclinometer. **Figure 4** shows the specimen installed on the frame rig. During the experiment, monotonic loading was applied gradually within a range of 0.2-0.5 kN. Unloading procedure was applied about 1/10 load prediction, continued by loading until failure mode is visible, characterized by considerable deformation, or the load becomes plateau or dropped abruptly.

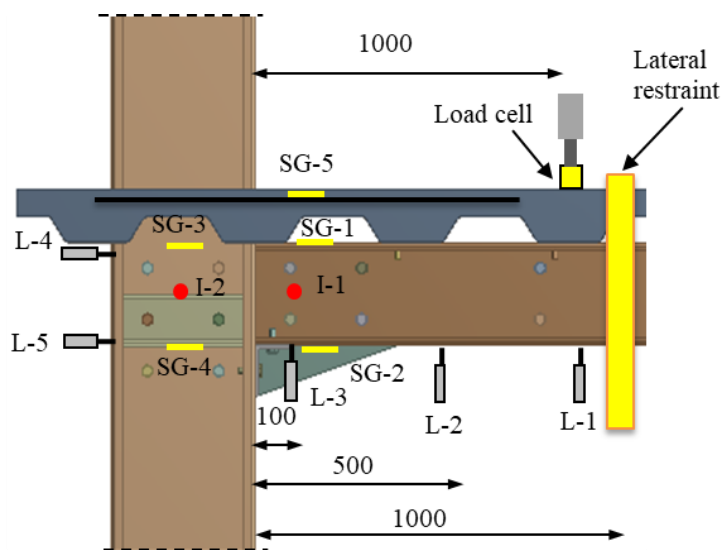

Figure 3. Isolated joint test arrangement

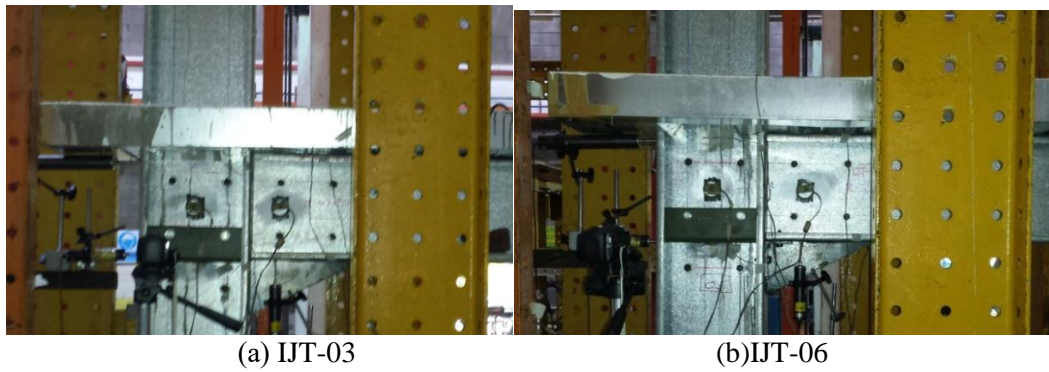

Figure 4. Composite connection specimen

3. Experimental results and discussion

To examine the failure behavior of the test object, the deformation of the specimens at the final load is presented in **Figure 5**, together with the P-Delta curve as shown in **Figure 6**. It is very clear that the two specimens exhibit identical deformation patterns, where the rotation of the joints results in pressure on rear column flanges due to concrete plates and anchor reinforcement (red arrow), at the same time the lower beam flanges push the front column flange (yellow arrow) leading to flexural deformation of the column flange (dotted red line). High-stress concentrations occurred in the compression zone and had caused local buckling at column flanges even though reinforced by angle stiffener. This could be due to the beam flange is no longer parallel to the angle stiffener due to the joint rotation. The ultimate loading was recorded as 71.30 kN with maximum deflection of 54.75 mm for specimen IJT-03. While IJT-06 gives more load resistance recorded as 75.4 kN but with lower deflection of 45.50 mm. This proves that there is the use of angle seat angle in IHT-06 has increased in both strength and stiffness of the connection.

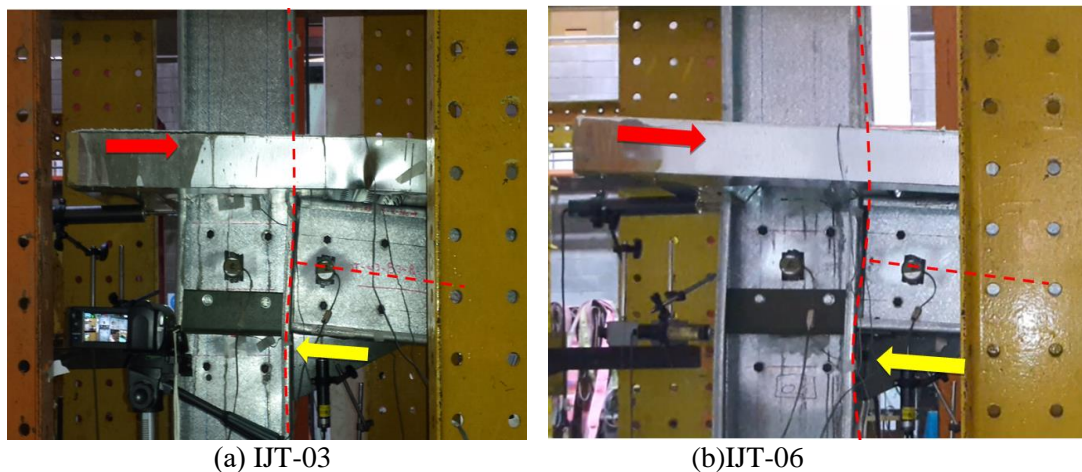

Figure 5.The failure mode of the specimens

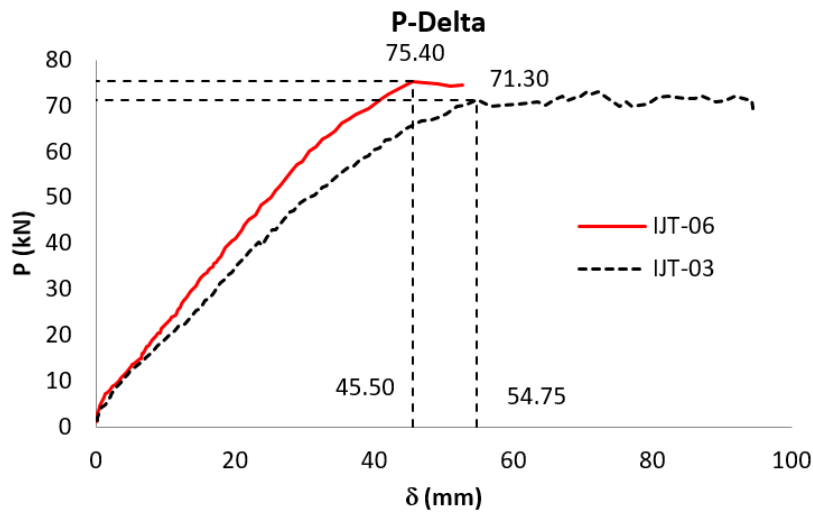
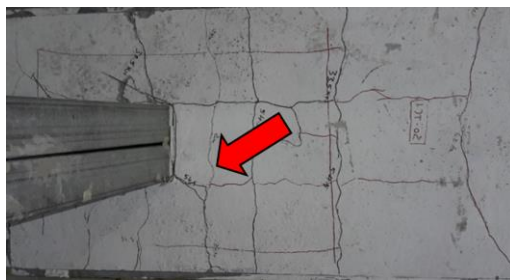

Figure 6. P-delta graph for IJT-03 and IJT-06

The crack patterns on the concrete plates for IJT-03 and IJT-06 started at a distance of about 120 mm from the face of the column (**Figure 7a** and **c**), where the thickness of the concrete slab is minimum. From the observations, the failure mode of concrete slab originated by transverse cracks for both specimens, and the first cracks happen at $P = 18$ kN for IJT-03 and $P = 20$ kN for IJT-06. The conical failure occurs around the shear connector after the load is increased to 55 kN for IJT-03 and 54.5 kN for IJT-06, respectively. As shown in **Figure 7b** and **Figure 7d**, no failure was detected to the shear connector. It means the shear transfer device is sufficiently stiff and able to transfer shear force from the concrete plate to the flange of the beam as well as the behavior of the composite connection [16, 17].



(a) IJT-03 first crack



(b) IJT-03 shear connector



(c) IJT-06 first crack



(d) IJT-06 shear connector

Figure 7. Failure mode of the concrete slab

Figure 8 and **Table 3** presents the experimental results of the moment-rotation curve. The stiffness of the connection is obtained from the slope of the curve. Very stiff results are found at the initial condition because the bolts are still tightened. The slope starts to decrease after the applied load reached more than 10 kN for both specimens. It could be due to crack of the concrete slab, at this stage the load was transferred gradually from concrete slab to the anchorage reinforcement bar. The ultimate moment achieved for IJT-03 was 71.3 kNm and the stiffness was 2220 kNm/rad. The increase in joint resistance was found for IJT-06 with 75.4 kNm and 2650 kNm/rad. It could be due to the influence of seat angle attached in the compression zone. Overall, the ratio of IJT-06 and IJT-03 is 1.06 (for moment resistance) and 1.19 (for stiffness). The rotational of 0.034 and 0.027 radians for both specimens indicate that the connection has a ductility behavior that very close to the ductility limit of 0.03 radians.

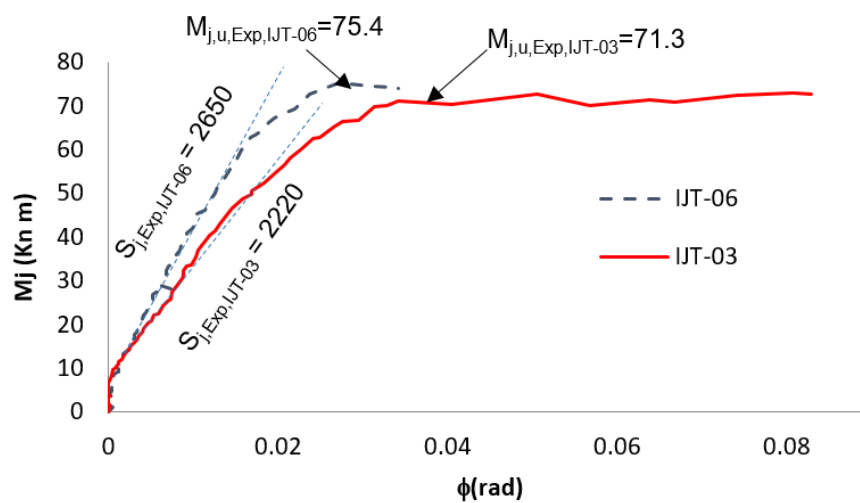

Figure 8. Moment-rotation of the specimens

Table 3. The stiffness and moment of the specimen

No	Test ID	Mj kNm	Sj kNm/rad
1	IJT-03	71.3	2220
2	IJT-06	75.4	2650

4. Conclusions

The investigations on isolated joint tests with composite connections combine with CFS were successfully carried out. The specimens failed due to the transverse crack of concrete slab, followed by a longitudinal crack and conical failure. The local buckling was found at column flange, although it has been reinforced by angle stiffener, it may happen due to the rotational of the connection generate the beam flange is longer in line with angle stiffener. The experimental results show that the use of a seat angle as reinforcement had increased the moment resistance and stiffness up to 1.06 and 1.19, respectively. It can be concluded that the increased in strength by the use of the angle seat is not that significant.

Acknowledgments

This research was funded by Sriwijaya University and Construction Research Centre, Universiti Teknologi Malaysia (UTM-CRC) grant No (Q.J130000.2409.04G50 and RJ130000.7309.4B235). The author would like to express the utmost gratitude to his supervisors, Professor Anis Saggaf and Professor Mahmood Md Tahir for his guidance and assistance throughout the study.

References

- [1] Yu C 2016 *Recent Trends in Cold-formed Steel Construction* (Woodhead Publishing)
- [2] Hadjipantelis N L Gardner and M A Wadee 2019 Design of prestressed cold-formed steel beams *J. Thin-Walled Struct* **140** p 565-578
- [3] Dubina D, V Ungureanu and L Gîlia Experimental investigations of cold-formed steel beams of corrugated web and built-up section for flanges 2015 *J. Thin-Walled Struct* **90** p 159-170.
- [4] Salih M N, Tahir M M, Abraham M A, Sulaiman A, Ngian S P, Firdaus M, Aminuddin K M and Khadavi 2019 Experimental study on flexural behaviour of partially encased cold-formed steel composite beams using rebar as shear connector *IOP Conference Series: Materials Science and Engineering*
- [5] Alhajri T M, Tahir M M, Azimi M, Mirza J, Lawan M M, Alenezi K K and Ragae M B 2016 Behavior of pre-cast U-Shaped Composite Beam integrating cold-formed steel with ferrocement slab *J. Thin-Walled Structures* **102** p 18-29
- [6] Saggaff A, Alhajri T, Ismail M, Alenezi K and Ragae M 2015 Finite Element Modelling of Innovative Precast Cold-Formed Steel Ferrocement as Composite Beam *Applied Mechanics and Materials* **752-753** p 539-43
- [7] Majdi Y, Hsu C-T T and Zarei M 2014 Finite element analysis of new composite floors having cold-formed steel and concrete slab *Engineering Structures* **77** p 65-83
- [8] Blum H and K Rasmussen Experimental investigation of long-span cold-formed steel double channel portal frames 2019 *J. of Const. Steel Research* **155** p 316-330.
- [9] Standard B 2005 BS EN 1993-1-8 2005 *Design of steel structures . Part 1-8: Design of joints* (London: British Standard Institution)
- [10] Lee Y H, Siang T C, Tahir M M, Shahrin M and Ngian S P Numerical Modelling of Stiffness and Strength Behaviour of Top-Seat Flange-Cleat Connection for Cold-Formed Double Channel Section 2013 *Applied Mechanics and Materials* **284-287** p 1426-1430
- [11] Tan C S, Tahir M M, Shek P N and Kueh A B H 2011 Experimental Investigation on Slip-In Connection for Cold-Formed Steel Double Channel Sections *Advanced Materials Research*, **250-253** 1038-41
- [12] Mohammadhosseini, H., Lim, N.H.A.S., Tahir, M.M., Alyousef, R., Alabduljabbar, H. and Samadi, M., 2019. Enhanced performance of green mortar comprising high volume of ceramic waste in aggressive environments. *Construction and Building Materials*, 212, pp.607-617.
- [13] Lawan M 2015 *Structural performance of cold-formed steel with self compacting concrete in a composite beam system* Universiti Teknologi Malaysia
- [14] Johnson R P 2011 *Designers Guide to Eurocode 4: Design of Composite Steel and Concrete Structures* (London: Institution of Civil Engineers publishing)
- [15] Mohammadhosseini, H. and Tahir, M.M., 2018. Production of sustainable fibre-reinforced concrete incorporating waste chopped metallic film fibres and palm oil fuel ash. *Sādhanā*, 43(10), p.156.
- [16] Tahir, M M, Mohammadhosseini, H, Alyousef, R, Leong, W K. and Salih, M N, 2019. Performance Evaluation of Pre-fabricated Footing Using Cold-Formed Steel of Lipped C-Channel Section. *Arabian Journal for Science and Engineering*, 44(10), pp.8225-8238
- [17] Tahir, M M., Mohammadhosseini, H, Ngian, S P. and Effendi, M K., 2018. I-beam to square hollow column blind bolted moment connection: Experimental and numerical study. *Journal of Constructional Steel Research*, 148, pp.383-398