

PAPER • OPEN ACCESS

Design of Device to Monitor Asthma Severity Using Mainstream Technology while Administering Medication

To cite this article: Mohamad Haikal Bin Mohamad Rosli *et al* 2020 *IOP Conf. Ser.: Mater. Sci. Eng.* **884** 012010

View the [article online](#) for updates and enhancements.

You may also like

- [Relationship between total serum immunoglobulin E levels, fractional exhaled breath nitric oxide levels and absolute blood eosinophil counts in atopic and non-atopic asthma: a controlled comparative study](#)
S K Shrestha, Arne Drews, Lucky Sharma et al.
- [Exhaled breath condensates in asthma: diagnostic and therapeutic implications](#)
Shamsah Kazani and Elliot Israel
- [Can exhaled volatile organic compounds predict asthma exacerbations in children?](#)
Dillys van Vliet, Agnieszka Smolinska, Quirijn Jöbbsis et al.



The Electrochemical Society
Advancing solid state & electrochemical science & technology

241st ECS Meeting

May 29 – June 2, 2022 Vancouver • BC • Canada

Abstract submission deadline: Dec 3, 2021

Connect. Engage. Champion. Empower. Accelerate.
We move science forward



Submit your abstract



Design of Device to Monitor Asthma Severity Using Mainstream Technology while Administering Medication

Mohamad Haikal Bin Mohamad Rosli¹, Rokini Kumarasamy² and MB Malarvili³

^{1,2,3}*School of Biomedical Engineering & Health Sciences,*

Faculty of Engineering, Universiti Teknologi Malaysia, 81310, Skudai, Johor Bahru, Johor, Malaysia

E-mail: malarvili@biomedical.utm.my

Abstract. A CO₂ measuring device is proposed based on a mainstream technique which would be able to classify the asthmatic condition while administering the medication to the patients. A SprintIR CO₂ sensor is used for extracting CO₂ concentration from the patient. In order to provide medication to the patient, a nebulizer is used that was combined together with the CO₂ measuring device which is designed by the 3D computer-aided design (CAD) software where the design is printed using 3D printing machine. The device uses a facemask to channel the gases where it measures the types of conditions which are 'No Asthma', 'Mild Asthma' and 'Severe Asthma'. The preliminary test results for 9 asthmatic patients and 10 non-asthmatic individuals shows that the device can measure their conditions successfully. Meanwhile, it can also deliver medication to the patients if the condition is 'Severe Asthma'.

1. Introduction

These guidelines Asthma is one of the breathing problems in human .The disease is caused by the tightening of the muscle due to the presence of thick mucus that disturbs the flow of airways [1]. When the volume of air that passes by is reduced that leads to variable symptoms, reversible airflow obstruction, and bronchospasm [2]. The signs and symptoms of an asthma attack are usually; shortness of breath, chest tightness, trouble sleeping, whistling sound while exhaling, and coughing or wheezing attacks.

There are many medications that are used in asthma treatment either for short-term treatment or long-term treatment. One of the asthma treatment devices that usually used by the asthmatic patient is nebulizer. The purpose of nebulizer therapy is to deliver a therapeutic dose of the desired drug as an aerosol in the form of respirable particles or in form of mist within a fairly short period of time which is usually 5 to 15 minutes [3]. It is most useful when a large dose of inhaled drugs is needed or when patients cannot use the handheld inhaler when the asthma attack appears. The nebulizer is attached with face mask or mouthpiece to deliver the drug to the patient.

Existing medical devices to monitor respiratory problems such as asthma have some limitations. The limitations and disadvantages need to be addressed to make sure the diagnosis process is accurate and reliable. Daily life monitoring needs of those patients who travel or do some activities, this portable device is the best for them. Many existing monitoring devices also did not provide any medication during the monitoring process. Adding an asthma treatment device to an asthma monitoring device is the novelty addressed in this paper. The medication device can help the patients to relieve the asthma attacks while the monitoring device can monitor the patient's asthma severity. If



the severity level is high and there is no sign of decreasing, the patients will need to see the doctor but if the severity is low and gradually decreasing, the patients not need to see the doctor.

Peak flow meter is also known as peak expiratory flow (PEF) and now commonly used in the diagnosis and management of asthma. The process of using this device is very tedious. The user needs to blow as hard as they can during the measurement. For the patient who has difficulties in blowing the air make the reading unreliable. Meanwhile, this device also did not show the severity of asthma rather than that just shows the volume of air exhaled. Meanwhile, Spirometer is a device that measures the volume of air that an individual inhales and exhales. The signal that primarily measured in Spirometer is the volume or flow of inhaled or exhaled gases. This device cannot determine the cause of the disease and it is not applicable to children or infants. This device also cannot determine the severity of asthma. On the other hand, Capnography is a device that provides the continuous measurement of partial pressure of CO₂ in expired respiratory gases. This device has become the standard for monitoring ventilatory status in the hospital. However, capnography is not suitable for home monitoring because it is very expensive and bulky. Again, this device also did not shows the severity of the asthma and no medication provided by this device.

Mainstream technology in a simple definition is a non-diverting system. A non-diverting system does not transport gases away from the sampling site and the sensor directly detects the gases [4]. The sensor placed at the airway that consists of the sample cell and infrared bench that results in a graphical representation of the time-varying CO₂ value. The CO₂ in the sample gas is absorbed by the radiation of infrared (IR) at some wavelengths and passes other wavelengths. A photodetector that is located on the other side of the airway adapter measures the transmitted radiation as it passes through the infrared transmitting windows of the cuvette.

This paper focuses on developing a low-cost monitoring device that would be able to measure real-time CO₂ gas from the exhalation process. The CO₂ sensor that uses a mainstream technology in this project to measure the CO₂ gas. The integration of the asthma treatment device is designed using a 3D designing software where the design is printed using a 3D printer. The asthma treatment device can administer the medicine when the severity of the asthma is high.

This paper is organized as follows. In section II we explained the methodology and the materials used to achieve the output. In Section III we discussed the primary outcomes acquired using this method. Finally in, Section IV we conclude and give the scopes of future research in this area.

2. Method and Materials

2.1 Block diagram of the proposed device

The block diagram of the proposed device is shown in Fig. 1. The block diagram contains four parts namely CO₂ signal acquisition unit, signal processing unit, a display unit, and medication unit. The CO₂ signal is acquired via the facemask and forwarded to the microcontroller for further processing.

Thereafter, the processed output is displayed on a small display (Organic Light Emitting Diode (OLED), 1.3''). The medication unit is used to deliver the medicine to the asthmatic patient while measuring the expired CO₂. The overview of the complete setup of the proposed device is presented in Fig. 2. The device consists of a facemask, CO₂ sensor, microcontroller, display, and nebulizer. The holder was designed using Solid Works software in order to connect both the nebulizer and sampling input line.

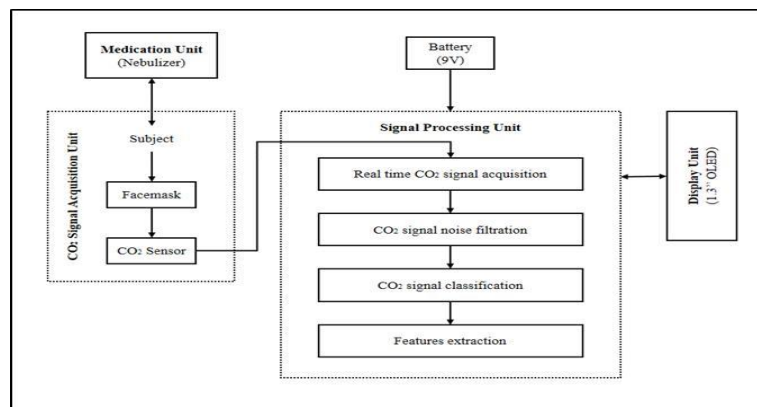

Figure 1. Block diagram of the device.

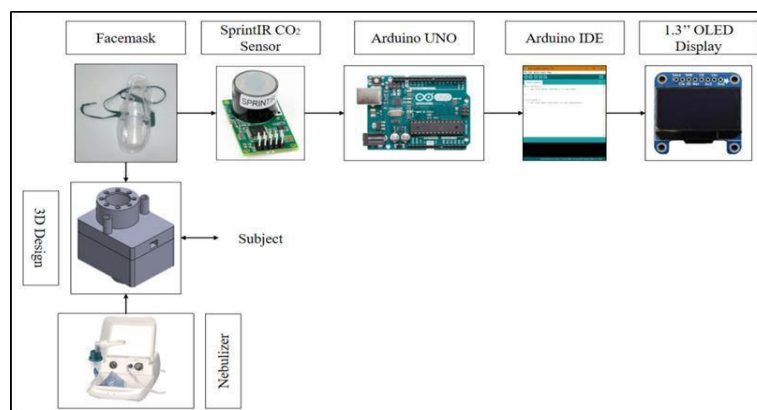

Figure 2. Block diagram of the complete setup of the device.

The CO₂ sensor is kept inside the holder and facemask is placed on the top of the sensor whereas the nebulizer is attached vertically to the opposite side of the sensor in order to avoid the false CO₂ reading causes by vaporized medicine.

2.1.1 CO₂ Signal Acquisition Unit

There are two main components in the signal acquisition unit namely facemask and CO₂ sensor. The facemask channeled the exhaled gasses from the patient to the CO₂ sensor which detect the CO₂ gas. SprintIRCO₂ sensor is selected to measure the CO₂ level due to its low response and warm-up time (less than 60 seconds), and the output range which lies from 0% to 20%. In addition, the sampling rate of the sensor is 20Hz. Furthermore, SprintIR CO₂ sensor also used advanced solid-state Indium Antimonide Light Emitting Diode and detectors for the CO₂ detection. These features offer a robust sensor with no moving parts and heated filaments, and incredibly low power requirements (3.2V to 5V) those are helpful in developing the real-time CO₂ measurement.

The sensor depends on the non-dispersive spectroscopy method, which absorbs the CO₂ molecules at a particular wavelength (4.3 μm) [5] in the infrared region and follows the Beer-Lambert law as given in Equation 1 [6-8]. This method has high selectivity, the ability to measure several types of gases by using different selective filters, and immunity to false alarms and poisoning since the detectors are not in direct contact with the gas.

Beer-Lambert law:

$$I=I_0 e^{-abt} \quad (1)$$

2.1.2 Signal Processing Unit

The Arduino Uno based on AtMega328 microcontroller is used to process the CO₂ signal [9,10]. Arduino Integrated Development Environment (IDE) software is used to program the Arduino Uno. The program is written in the Arduino IDE software for retrieving and processing (filtering, features extraction and display) the CO₂ data which is based on Arduino 'C' language. The required library is also included in Arduino IDE software in order to communicate and display the CO₂ data.

2.1.3 Display Unit

An adafruit monochrome 1.3" OLED screen is used to display the CO₂ measurement in the form of a graph. The OLED is preferred to use due to its unique specifications such as brighter than liquid crystal display (LCD) and does not require backlighting, hence, needed less power compared with other available display. The display only required 3.3V to operate and can be powered from Arduino Uno. It has the voltage regulator that can convert 5V from Arduino Uno to 3.3V to operate. The size (128x64 pixels) of the display is sufficient in order to display the graph that can be easily understood by the patient.

2.1.4 Medication Unit

The nebulizer is used for this purpose. It is attached to the monitoring device in a way so that it can deliver medicine to the patients while the asthmatic conditions are monitored. The nebulizer can be detached from the monitoring system when it is not in use. Fig. 3(a) shows the medicine reservoir and tube used to connect the nebulizer with the monitoring device. The medicine reservoir is attached to the monitoring device while the tube is connected to the nebulizer. Another tube is used to deliver the medicine from the holder to the facemask as shown in the Fig. 3(b).

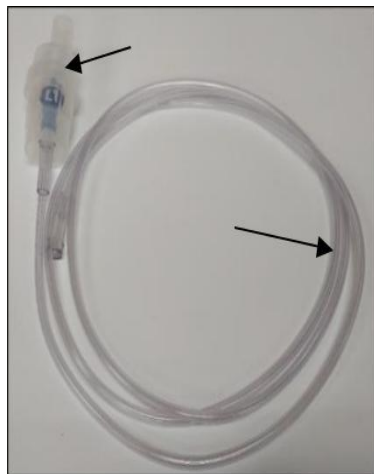

Figure 3(a). Medicine reservoir and tube for the nebulizer.



Figure 3(b). Tube to deliver medicine from the holder to the facemask.

2.1.5 Algorithm of the Device

Fig. 4 shows the flowchart for the CO₂ acquisition and display. In this, the algorithm adjusts the size of the display so that it can show the CO₂ measurement. The value of CO₂ is measured in part per million (ppm) during the recording. The value of the CO₂ is multiplied with a certain value to make sure the measurement is correct. Thereafter, the algorithm is developed to differentiate asthma and non-asthma condition based on the CO₂ values exhaled by the patient. The value for 'Mild Asthma' condition is set from 15000 ppm to 25000 ppm; 'Severe Asthma' condition is set from 5000 ppm to 15000 ppm while the value for 'No Asthma' is set from 25000 ppm to 55000 ppm.

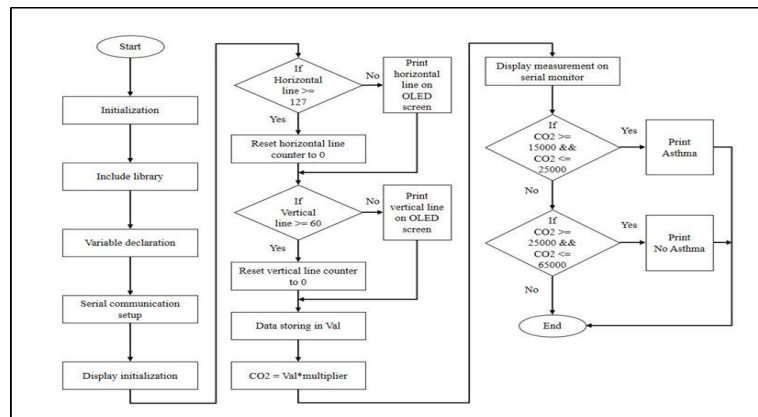

Figure 4. Flowchart of the coding algorithm.

2.2 3D Design Process

SolidWorks software is used to the 3D design process for making the casing for the device. There are three parts to the 3D design process of the device, namely, a casing for sensor, holder, and microcontroller. The casing of the sensor holds the sensor and it was placed inside the holder. The sensor was isolated to prevent the damage and false reading may be due to the medicine. The holder was made in order to integrate both the facemask and nebulizer. The pathway for the medicine was made inside the holder which allows the medicine to pass till the facemask via sampling tube. Furthermore, the casing for the microcontroller was designed to place the Arduino Uno, OLED display, and battery. The 3D design was printed using 3D printing machine. Here, the filament Acrylonitrile Butadiene Styrene (ABS) was used to print the design in a 3D printer.

2.3 Data Collection and Analysis

Data are recorded from the students of Universiti Teknologi Malaysia (UTM). All the subjects are asked to relax and sit comfortably. Then, the subjects are instructed to breathe in and out normally, in a relaxed manner at their own pace through the facemask and avoid breathe using their mouth. The CO₂ measurements are recorded simultaneously for 2 minutes for each subject. Furthermore, every 2 minutes of the recorded data are segmented into three parts for further analysis. Each part consists of three consecutive breaths cycles that have regular shapes.

The data analysis was performed using LabVIEW software. LabVIEW is a graphically programmed computer language for real-time instrumentation. The extraction of the breath cycle was based on the best shape that seems to be regular in shape. Then, the consecutive parts of three breathe cycle of CO₂ signals are called into LabVIEW in order to extract the Hjorth parameters [11]. It measures the mean power of each breath signal and analysis involved slopes of the curve, which resembles a strong correlation with the CO₂ signal. The values obtained for Hjorth parameters are based on the variance of the signals. The Hjorth's parameters are considered to be the significant parameter in order to differentiate asthma and non-asthma condition as reported by Kean et al [12]. In this study, we considered extracting Hjorth Activity (HA), Hjorth Mobility (HM) and Hjorth Complexity (HC). These three parameters are extracted from each breath cycle. The calculation and appearance of these parameters are shown in Fig. 5.

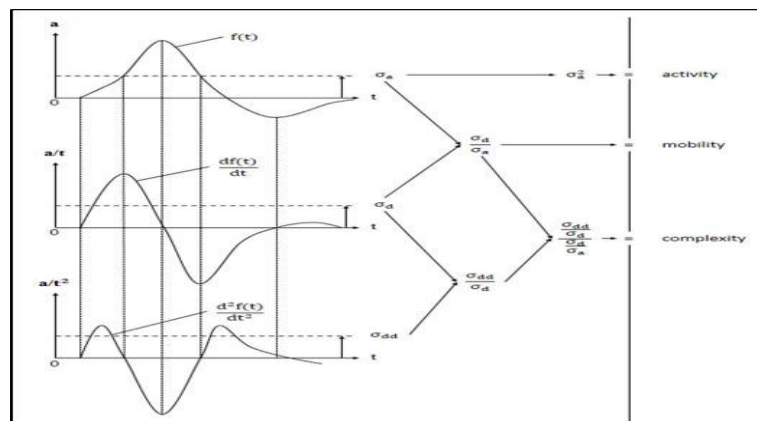

Figure 5. Calculation of HA, HM and HC parameters

Furthermore, statistical analysis was performed using SPSS software to find the significant differences (p -value) between the signals. IBM SPSS platform offers advanced statistical analysis, a huge library of machine learning algorithms, text analysis, open source extensibility, integration with big data and seamless deployment into applications. The collected data from the LabVIEW were normalized before analyzing, in order to have more close information on CO_2 values for asthma and non-asthma. Additionally, it also helps in reducing the computation time. The significance value was set at $p < 0.05$. The data was divided into two groups, namely, asthma and non-asthma. Each group has three classes based on the Hjorth parameters which are HA, HM, and HC. For this, mean and standard deviation of the CO_2 signal was computed for both asthma and non-asthma signals for each Hjorth's parameter. Further, the normality distribution of each feature was analyzed with respect to each reading. For this, the Skewness and Kurtosis (z -values) were calculated to verify the normality of the data for both asthma and non-asthma condition. The z -value (± 1.96) and Shapiro-Wilk p -value ($p > 0.05$) are considered statistically significant for normality of data [13-17].

3. Result and Discussion

3.1 3D Design

The 3D design process of the device using SolidWorks covers the casing for the sensor, holder of device and microcontroller. The 3D design of the device is shown in Fig. 6(a), 6(b) and 6(c). Fig. 6(a) shows the design of the casing to put the sensor. Fig. 6(b) shows the design of the holder for the sensor with the casing, facemask, and nebulizer. Fig. 6(c) shows the design of the casing for the microcontroller, display, and battery. The dimension of the design is carefully measured to prevent the components from moving especially the CO_2 sensor and to make sure the exhaled gas effectively detected by the sensor. Additionally, if there is a gap or hole in the pathway of the medication, it will damage the sensor.

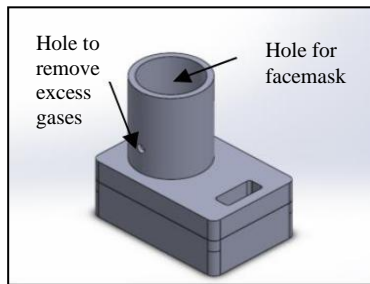

Figure 6 (a). Design of the casing for sensor.

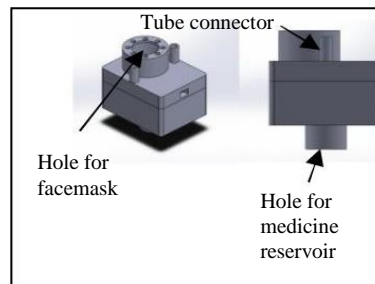

Figure 6 (b). Design of holder.

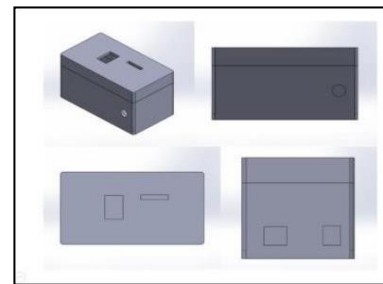

Figure 6 (c). Design of microcontroller casing.

The dimension for the holder of the device is 6.1 cm x 4.72 cm x 4 cm which looks like a square. The diameter of the hole to put facemask is 2 cm while the diameter for the hole to put the medicine reservoir is 1.75 cm. There are eight holes with diameter 0.4 cm near the hole to connect the facemasks to remove excess gas. The medicine was delivered from the nebulizer to the patient through the hole at the bottom of the holder. Furthermore, the medicine flows through the pathway inside the holder and go to the tube which is connected to the facemask. The diameter for the tube connector is 0.47 cm to connect the tube from the holder to the facemask. There are two holes with diameter 0.3 cm at the casing of the sensor to remove the excess gas to prevent a false reading.

3.2 Device Prototype

The prototype of the device is shown in Fig. 7. The real time CO₂ measurement is shown on the OLED screen in ppm value. Fig. 8 shows the complete setup of the device tested on the subject.

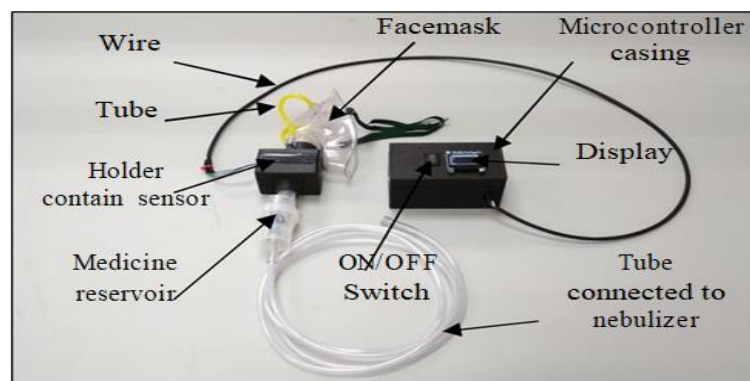

Figure 7. Device prototype.



Figure 8. Complete setup of the device.

Fig. 9 below shows the graph of the CO₂ signal displayed on the OLED screen showing the real-time CO₂ measurement. It also shows the condition of the patient either 'Asthma' or 'No Asthma'.



Figure 9. Screen of the device.

3.3 Data Collection

Fig.10 (a) and (b) shows obtained CO₂ signal from the asthmatic and non-asthmatic patient. Fig. 11 (a) and (b) shows the segmented signal for further analysis.

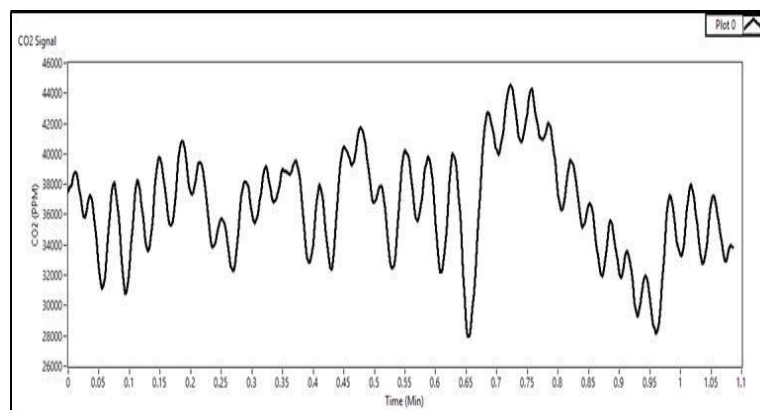

Figure 10 (a). Obtained CO₂ signal from asthmatic subject.

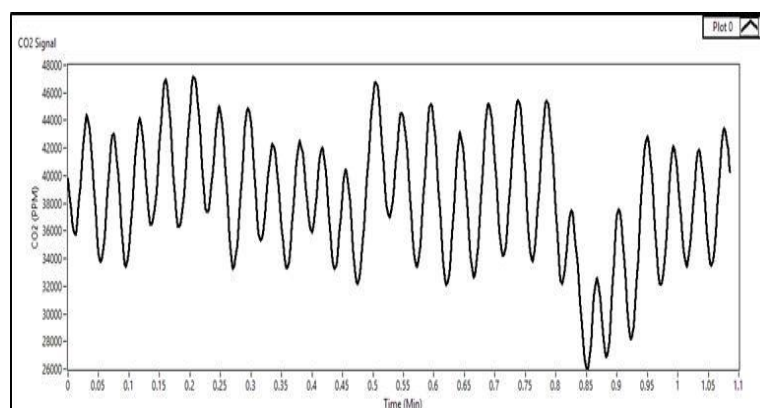

Figure 10 (b). Obtained CO₂ signal from non-asthmatic subject.

From the collected signals, graph not showing the significant difference between the asthmatic and non-asthmatic signal. So we prefer to extract other features to classify asthmatic and non-asthmatic patients.

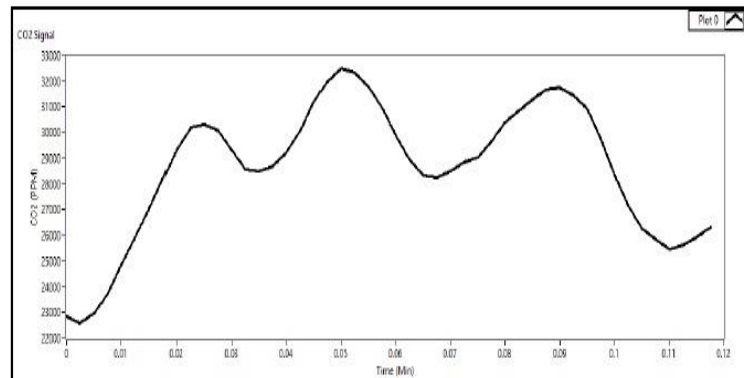

Figure 11 (a). Three breathe cycle extracted from the asthmatic patient.

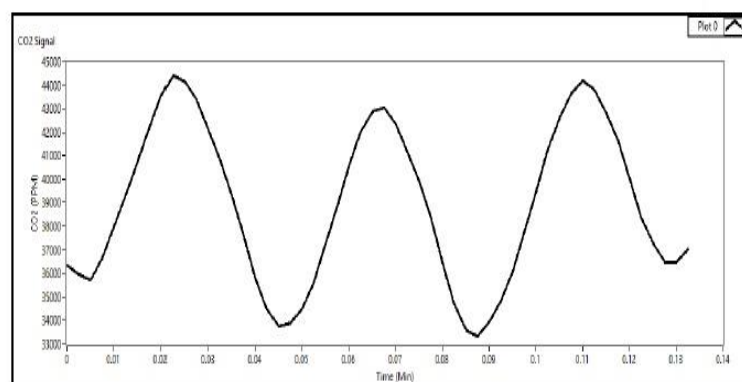

Figure 11 (b). Three breathe cycle extracted from the non-asthmatic patient.

3.4 Data Analysis

The data were collected from 9 asthmatics and 10 non-asthmatic subjects. Each data was segmented into 3 parts, each part contains 3 breath cycles having a regular shape. Thus 9 breath cycles were extracted from each data for further analysis. Therefore, this study includes the analysis of 81 breath cycles, extracted from the 9 asthmatic subjects. Similarly, 90 breath cycles were extracted from the 10 non-asthmatic subjects for the further analysis. Further, three features, namely, HA, HM, and HC, were extracted from each breath cycle for asthmatic and non-asthmatic conditions and a mean value was calculated for each 3 breath cycles to verify the statistically significant difference between asthma and non-asthma condition. Furthermore, in order to identify the mean difference between asthma and non-asthma, a t-test was performed based on the normality of the data distribution. Finding revealed that data were not normally distributed for both healthy and asthmatic subjects with Shapiro-Wilk p-values ($p > 0.05$) and z-values ($-1.96 > z > +1.96$) [10-15]. Hence, a non-parametric t-test was performed in order to compare the mean of HA, HM, and HC in asthma and no-asthma condition. Table I listed the z-values and Shapiro-Wilk (p -value) for asthma and non-asthma.

Table 1. The Z-values and Shapiro-Wilk (*p*-value) for each parameter.

Parameters	Skewness -		Kurtosis -		<i>p</i> -value	
	Z-value		Z-value			
HA	2.48	3.26	0.64	0.73	0.002	0.000
HM	4.16	4.40	4.43	5.06	0.000	0.000
HC	4.19	5.98	3.30	8.36	0.000	0.000

Table II shows the mean \pm SD and *p*-values for the asthmatic and non-asthmatic data for different parameters. Based on Table II, only HM parameter indicates a significant difference between the asthmatic and non-asthmatic subjects with the *p*-value of 0.002 which is less than 0.05. Whereas, HA and HC parameters indicate no significant differences between the asthmatic and non-asthmatic subjects and their *p*-value are 0.291 and 0.321 which is more than 0.05.

Table 2. HA, HM, and HC parameters (mean \pm SD) comparison between asthmatic and non-asthmatic.

Parameters	Asthmatic	Non-asthmatic	<i>p</i> -value
HA	0.39 \pm 0.38	0.46 \pm 0.33	0.291
HM	0.49 \pm 0.38	0.24 \pm 0.34	0.002
HC	0.34 \pm 0.39	0.27 \pm 0.35	0.321

The feature HA is the squared standard deviation of the amplitude of the recorded CO₂ signal. On the other hand, HC gives the measure of excessive details with reference to the "mildest" possible curve shape, the sine wave, this corresponding to unity. The feature HM depicts the standard deviation of the slope with reference to the standard deviation of the recorded CO₂ signal. Therefore, our preliminary findings shows that the analysis on the slope of the CO₂ waveform able to significantly differentiate the asthmatic and non-asthmatic groups. As a result of estimation in the slope, the feature HM performs better than HA and HC.

4. Conclusion and Future Work

In this paper, we propose a low-cost asthma monitoring device using mainstream technology. The monitoring device is integrated with nebulizer so that it can monitor the asthma severity level while administering medication. In this research, we used SprintIR CO₂ sensor, Arduino Uno, and OLED display. Moreover, the developed device is tested and recorded for 19 subjects. The recorded data is analyzed using LabVIEW software to extract the Hjorth parameters. The Hjorth parameters are further analyzed using SPSS to investigate the significant differences between asthma and non-asthma signal. Our preliminary finding reveals that only Hjorth Mobility (HM) parameter shows significant differences between asthmatic and non-asthmatic signal while Hjorth Activity (HA) and Hjorth Complexity (HC) are not statistically significant. In future, the efficacy of various feature extraction method will be investigated to obtain a better result. In addition, larger database required to validate the device. So that this classification is more accurate.

Acknowledgement

This research is conducted as a part of the flagship grant of Fundamental Research Grant Scheme (FRGS), vote no. (R.J130000.7745.4F943), supported, by Ministry of Higher Education (MOHE) and also Universiti Teknologi Malaysia for providing the facilities and laboratory equipment for the completion of the research.

References

- [1] Malik S A, Singh O P, Nurifhan A and Malarvili M B 2016 Portable respiratory CO₂ monitoring device for early screening of asthma. *Proc. ACEC* 90-4
- [2] Balakrishnan M, Kazemi M and Teo A H 2012 A review of capnography in asthma: A new approach on assessment of capnogram *Biotechnol. Bioinf. Bioeng.* **2** 555-66
- [3] Nebulizer therapy. Guidelines. British Thoracic Society Nebulizer Project Group. 1994 *Thorax.* **52** 4
- [4] Jaffe M B 2002 Mainstream or sidestream capnography? White paper (US: Respirationics Novamatrix, Inc, Wallingford, Conn.)
- [5] Rubio R, Santander J, Marco S, Fonseca L, Fonollosa J and Moreno M 2005 Non-selective NDIR array for gas detection *Proc. SPIE 5836, Smart Sensors, Actuators, and MEMS II*
- [6] Kuhn K, Pignatelli E and Schutze A, 2013 Versatile Gas Detection System Based on Combined NDIR Transmission and Photoacoustic Absorption Measurements *J. IEEE Sensors* **13** 934-940
- [7] Xu S. and Chen M 2012 Design and modeling of non-linear infrared transducer for measuring methane using cross-correlation method *Measurement* **45** 325-332
- [8] Zhu Z, Xu Y and Jiang B, A 2012 One ppm NDIR Methane Gas Sensor with Single Frequency Filter Denoising Algorithm *Sensors* **12** 12729
- [9] Shabry N A N B M, Singh O P, Sardana P, Hisham R and Malarvili M B 2017 Home Based Fetal Heart Rate Monitor *Int. J. App. Eng. Res.* **12** 813-17
- [10] Ahmad H A B, El-Badawy I M, Singh O P, Hisham R B and Malarvili M B 2018 Fetal heart rate monitoring device using condenser microphone sensor: Validation and comparison to standard devices *Technol. Health Care* **26** 573-9
- [11] Singh O P, Mekonnen D and Malarvili M B 2015 Labview based ECG Patient Monitoring System for Cardiovascular Patient using SMTP Technology” *J Med. Eng.*
- [12] Kean T T, Teo A H and Malarvili M B. 2010 Feature Extraction of Capnogram for Asthmatic Patient *Second Int. Conf. on Computer Engineering and Applications* 11242717
- [13] Singh O P, Ahmed I B and Malarvili M B 2018 Assessment of newly developed real-time human respiration carbon dioxide measurement device for management of asthma outside of hospital *Technol. Health Care* **26** 785-94
- [14] Doane D P and Seward L E 2011 Measuring skewness *J. Stat.Educ.* **1** 1-18
- [15] Nornadiah M R and Yap B W 2011 Power Comparisons Of Shapiro Wilk, Kolmogorov-Simrnov, Lilliefors and Anderson-Darling Tests *J. Stat. Modelling Anal.* **2** 21-33
- [16] Shapiro S S and Wilk M B 1965 An Analysis of Variance Test for Normality: Complete Samples (UK: Oxford University Press) **52** pp 591–611
- [17] Singh O P, Howe T A and Malarvili M B 2018 Real-time human respiration carbon dioxide measurement device for cardiorespiratory assessment *J. Breath Res.* **12** 026003