

See discussions, stats, and author profiles for this publication at: <https://www.researchgate.net/publication/346577903>

A Single Objective Flower Pollination Algorithm for Modeling the Horizontal Flexible Plate System

Conference Paper · December 2020

CITATIONS

0

READS

37

6 authors, including:



Muhamad Sukri Hadi
Universiti Teknologi MARA

36 PUBLICATIONS 59 CITATIONS

[SEE PROFILE](#)



Annisa Jamali
University Malaysia Sarawak

43 PUBLICATIONS 121 CITATIONS

[SEE PROFILE](#)



Hanim Mohd Yatim
University of Kuala Lumpur

29 PUBLICATIONS 53 CITATIONS

[SEE PROFILE](#)



Hussin Talib
Universiti Teknologi Malaysia

26 PUBLICATIONS 84 CITATIONS

[SEE PROFILE](#)

Some of the authors of this publication are also working on these related projects:



Flexible Robotics Arm [View project](#)



PID controller for NARX and ANFIS models of marine pipe cylinder undergoes vortex induced vibration [View project](#)

A Single Objective Flower Pollination Algorithm for Modeling the Horizontal Flexible Plate System

Siti Zakiah Maseri
Faculty of Mechanical Engineering
Universiti Teknologi MARA
Shah Alam, Malaysia
sitizakiahmaseri@gmail.com

*Muhamad Sukri Hadi
Faculty of Mechanical Engineering
Universiti Teknologi MARA
Shah Alam, Malaysia
msukrihadi@uitm.edu.my

Annisa Jamali
Faculty of Engineering
Universiti Malaysia Sarawak
Kota Samarahan, Malaysia
jannisa@unimas.my

Hanim Mohd Yatim
School of Mechanical Engineering
Universiti Teknologi Malaysia
Johor, Malaysia
hanim.my@utm.my

Mat Hussin Ab Talib
School of Mechanical Engineering
Universiti Teknologi Malaysia
Johor, Malaysia
mathussin@utm.my

Intan Zaurah Mat Darus
School of Mechanical Engineering
Universiti Teknologi Malaysia
Johor, Malaysia
intan@utm.my

Abstract— Flexible plate structure is a chosen technology used for many applications since past decades ago. However, this structure has a disadvantage that needs to be avoided which is easy to vibrate. Thus, this project presents the modelling of horizontal flexible plate system using bio-inspired flower pollination algorithm. The objective is to obtain an accurate model of the real system in the simulated environment. The collected of real vibration data through experimental study was then utilized to develop the dynamic system model based on linear autoregressive with exogenous (ARX) model structure and optimized by flower pollination algorithm (FPA). The algorithm is a novel bio-inspired optimization algorithm that mimics the real-life processes of the flower pollination. The gained model in this simulation is approved utilizing the most minimal mean squared error, correlation tests, and pole zero graph stability due to check the robustness of the model. The performance of the developed model was then compared with the conventional algorithm known as recursive least square (RLS). The best model achieved in this study will be used as a platform of controller development using active vibration control technique.

Keywords—recursive least square, flower pollination algorithm, evolutionary swarm algorithm, system identification, flexible plate structure

I. INTRODUCTION

In the past several decades, a flexible structure is widely used in various applications. Based on previous researches, this structure has been used in various study such as fluid, chemical, spacecraft and many more [1–4]. Different elements will be implemented to the structure like frames, shells, beams, and plates for different applications in order to produce good effect results [5]. Flexible structure systems are known to demonstrate an intrinsic property of vibration when subjected to disturbance forces, leading to components and structural damage [6].

The thin rectangular plate structures are the most commonly used in the industrial applications such as bridge decks, solar panels, airport baggage transport conveyor and electronic circuit board design [5]. Most of the industry's applications use flexible structure compared to rigid structures due to its advantages such as lightweight, reliable and high efficiency. In some reasons, the advantages can be the downside of a flexible structure. The lightweight of the flexible structure can be easily influenced by the vibration which will cause damage to the structure [7]. Thus, the

unwanted vibration should be removed to sustain an effective system.

In order to obtain a better controller, a proper model of the system need to be modelled at initial. Recently, one of the well-known methods has been given attention by the researchers, which is using system identification technique. System identification is a candidate used to describe mathematical tools and algorithms that build dynamical models from measured data. The practical application domains include pattern recognition, time-series prediction, Boolean function generation, and symbolic regression [6].

System identification had experienced an evolution from time to time. Previously, the methods used to model a structure are Finite Difference and Finite Element methods which are also categorized in system identification. In some time, the conventional algorithm is gradually prefaced as one of the methods to represent the modelling. The latest system identification that had been developed by the researchers is an evolutionary swarm algorithm which is bio-inspired the real-life processes. For instances, the algorithms that recently done by the researchers are particle swarm optimization (PSO), artificial bee colony (ABC), bat algorithm (BAT), flower pollination, firefly and many more.

Recently, a great attention has been received by flower pollination algorithm due to its ability in solving computationally complex and mathematically intractable problems. Inspired by the thoughts of previous research, thus, this study presents the modeling of a horizontal flexible plate structure using evolutionary swarm algorithm via flower pollination algorithm (FPA) and the performance of proposed method will be compared with the conventional algorithm known as recursive least square (RLS).

II. EXPERIMENTAL SETUP

An information securing framework is utilized as an accumulation of programming and equipment to gauge or control the physical qualities of a framework. A total information procurement framework comprises of DAQ equipment, sensors and actuators, signal conditioning equipment, and a PC running DAQ programming. Along these lines, from the test arrangement, the info yield vibration information were gathered for flat adaptable plate structure framework. The exploratory apparatus included the parts of mechanical, electrical, and hardware which are work

generator, control enhancer, attractive shaker, DAQ framework, and piezo-pillar type accelerometer.

The primary part for this examination is the adaptable structure displayed by square, meager, and level aluminium plate and has the steady estimation which is 0.6m for each side. The position picked for the plate structure is flat with all edges clipped. The chose excitation point will create the method of vibrations of the adaptable plate structure. So as to energize the structure, a self-form attractive shaker was put a ways off of 1cm parallel to the changeless magnet connected at the excitation point. The attractive shaker was associated with capacity generator through power enhancer in which the capacity generator is an electronic test gear to produce various sorts of electrical waveforms during making of incitation force [8].

Next, two bits of piezo-shaft type accelerometers were connected at two unique positions which are perception and identification focuses. The reason for the accelerometers is to get the increasing speed signal in the trial. The National Instrumentation (NI) and information procurement framework (DAQ) which are mounted inside the PC used to examine the info yield analyse information where the accelerometers were straightforwardly associated [9]. Fig. 1 demonstrates the test arrangement utilized in this examination for accumulation information while Fig. 2 demonstrates the schematic chart of experimental arrangement.

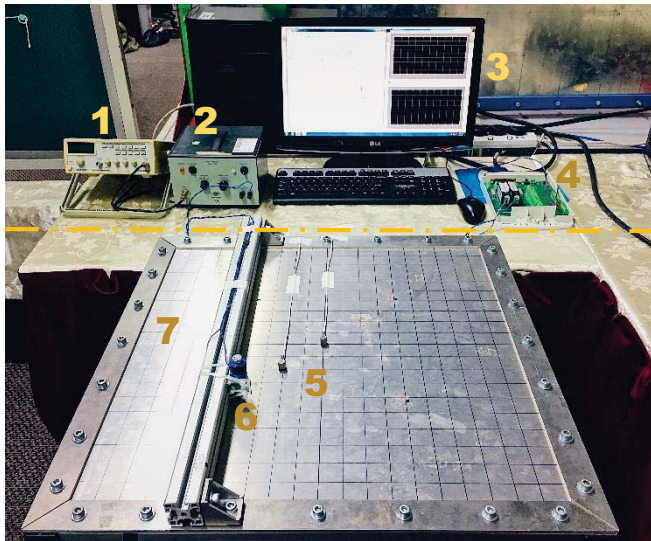

Fig. 1. The experimental arrangement utilized in this examination a) the combination of information securing and instrumentation framework into the test rig, b) perspective on the sensors from the base of the plate [10].

TABLE I. NAME OF COMPONENT IN EXPERIMENTAL SETUP

No.	Instrumentation
1.	Function Generator
2.	Power Amplifier (Type 2706)
3.	Personal Computer with Matlab Software
4.	Data Acquisition System (PCI 6259)
5.	Accelerometer (Kistler-8636C50)
6.	Magnetic Shaker
7.	Experimental Rig

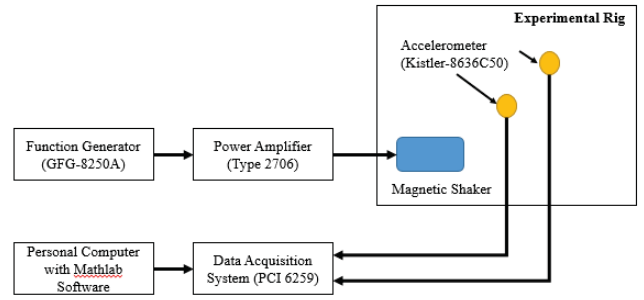

Fig. 2. The schematic diagram of experimental setup [10].

III. SYSTEM IDENTIFICATION

System identification is a potential technique in obtaining the accurate model of dynamic system based on input-output acquired data from experiment. This method represent the dynamic response in the form of mathematical models [9]. Previously, there are conventional algorithm such as least square, recursive least square, neural network, differential evolution and many more. However, recently, there is improvement from conventional algorithm to evolutionary swarm algorithm. Evolutionary swarm algorithm which is also known as intelligent algorithm is inspired from nature in solving the optimization problem. The example of the intelligent algorithm are bacterial foraging, genetic algorithm, cuckoo search, flower pollination and many more.

A. Recursive Least Square (RLS)

Recursive Least Square Algorithm (RLS) is one of the ordinary calculations that had been utilized to show the gathered information around to the plate structure. This customary calculation will deliver the fix result for the approval tests for various model request consequently, it is simpler contrasted with intelligent algorithm. In RLS, there is a parameter which loads late information all the more vigorously known as an overlooking variable where the worth is in the scope of 0 to 1 [11]. The hypothetical formula for RLS calculation is represented as below [12]:

$$\theta(i) = \theta(i-1) + K(i) * E(i) \quad (1)$$

$$E(i) = y(i) - x(i)^T \theta(i-1) \quad (2)$$

$$K(i) = \frac{\lambda^{-1} P(i-1) x(i)}{1 + \lambda^{-1} x(i)^T P(i-1) x(i)} \quad (3)$$

$$P(i) = \lambda^{-1} P(i-1) - \lambda^{-1} K(i) x(i)^T P(i-1) \quad (4)$$

$\theta(i)$ is a present parameter vector, $K(i)$ is the least square weighting element, $P(i)$ is a matrix that corresponding to change of recently evaluated vector, $E(i)$ is present estimation error, $\theta(i-1)$ is recently assessed vector, λ is a forgetting factor, $x(i)$ and $y(i)$ is the system input and output respectively [13].

B. Flower Pollination Algorithm (FPA)

Flower Pollination Algorithm (FPA) had been found by Yang (2012) and it is roused with the fertilization procedure of plants [14]. This FPA mirrors the propagation of flower by means of fertilization process. To put it plainly, flower fertilization is connected with the exchange of pollen grains

because of flying creatures or creepy crawlies which act as pollinators [15]. here are two significant types of fertilization which are biotic and abiotic fertilization and it is plainly clarified in 4 guidelines [16]:

1. Biotic or cross-fertilization is considered as global fertilization process and the dust conveying pollinators move in a manner that obeys Levy flights.
2. Abiotic or self-pollination is viewed as local pollination process.
3. Pollinators can create bloom consistency which is proportionate to propagation strength which is relative to the similarity of two blossoms included.
4. The connection or exchanging the local and global pollination can be constrained by utilizing switch likelihood $p \in [0, 1]$.

As to be justifiable, the rules above should be changed over into updating conditions. In example, the main standard expressed is identified with global fertilization. For this procedure, the flower pollen gametes are conveyed by the pollinators, for example, bugs or flying creatures. These pollinators will travel to every part of the dust over a long separation in light of the fact that these pollinators frequently fly and move in an any longer range. Subsequently, this progression is represented by:

$$x_i^{t+1} = x_i^t + L(x_i^t - gbest) \quad (5)$$

Where x_i^t is the pollen i at iteration t and $gbest$ is the current best solution found among all solutions at the current generation. L is the Levy flights dependent on step size relates to the quality of the fertilization. L can be utilized to copy the conduct of creepy crawlies which can travel through long separations utilizing different separation steps. This Levy distribution legitimate for huge advance size ($s > 0$).

$$L = \frac{\lambda \Gamma(\lambda) \sin\left(\frac{\pi\lambda}{2}\right)}{\pi} \left(\frac{1}{s^{1+\lambda}}\right) \quad (6)$$

Here, $\Gamma(\lambda)$ is the standard gamma work with $\lambda = 1.5$ [17]. For local fertilization, it is represented as:

$$x_i^{t+1} = x_i^t + \epsilon(x_j^t - x_k^t) \quad (7)$$

In which, x_j^t and x_k^t are pollen from various lower of same plant species copying the flower consistency in a limited neighborhood.

Bloom fertilization exercises can be occurred at both local and global. Be that as it may, in a genuine nature process, nearby bloom patches are bound to be pollinated by local blossom dust contrasted with those distant. So as to copy this, rule 4 is applied where switch likelihood is proficiently used to switch between global to local fertilization [16]. Fig. 3 presents the flowchart of FPA.

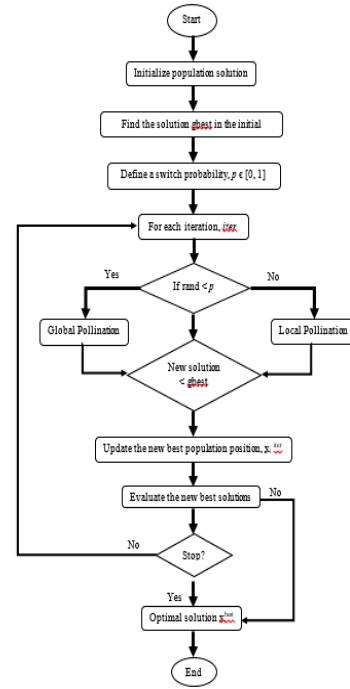

Fig. 3. Flow chart for flower pollination algorithm system identification.

IV. RESULT AND DISCUSSION

System identification was selected in developing mathematical model of flexible plate system via evolutionary swarm algorithm. This algorithm were inspired with the biological system happen in nature. The algorithm proposed for this study is flower pollination (FPA) where this algorithm mimics the reproduction of flower via pollination process. Based on previous research, FPA had been applied in least number of engineering application [18]. Thus, this algorithm was selected in this study in order to achieve the main purpose which is to develop mathematical modelling for determining the transfer function of horizontal flexible plate system.

The system representation was developed based on ARX model structure in MATLAB software. Heuristic method was chosen order as there is no specific knowledge in selecting the best model order. From the previous experiment, 5000 datasets had been collected and divided into two groups of data points. Both divided groups consists of 2500 data points respectively. The first group known as training data points was used in estimating the model parameters whilst the second group was used for validation of the estimated parameter. There were three considered criteria in obtaining the best represented model which are listed below:

- The lowest mean squared error (MSE) in testing data system.
- Correlation test for the developed model must be within 95% of confidence level.
- The system has a very good stability.

A. Modelling using Recursive Least Square

For RLS tuning process, two parameters that need to tune which are forgetting factor and model orders. Table 1 shows the parameters used to obtain the best model representing flexible plate structure. Based on the tuning, it shows that with the factor of 0.4 and model order of 12, the best model

for flexible plate structure was achieved. The model had achieved the lowest mean squared error for RLS identification which are 2.0×10^{-3} and 5.1240×10^{-4} for training and testing data, respectively. Figs. 4 and 5 show the actual and prediction outputs of the system in the time and frequency domain, respectively, while Fig. 6 shows the error between actual and estimated outputs of the system.

TABLE II. THE SET OF PARAMETERS USED FOR RLS MODELING

Parameters	Value
Model order	12
Forgetting factor	0.4

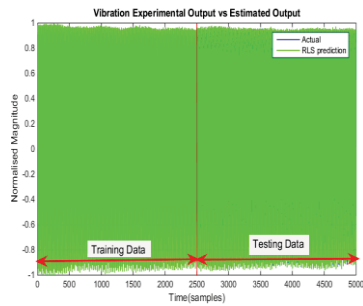

Fig. 4. Actual and prediction outputs of the system in the time domain using RLS modelling chart for flower pollination algorithm system identification.

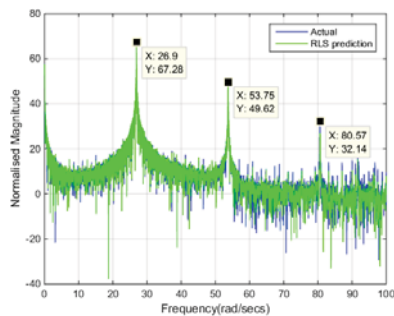

Fig. 5. Actual and prediction outputs in the frequency domain using RLS modelling.

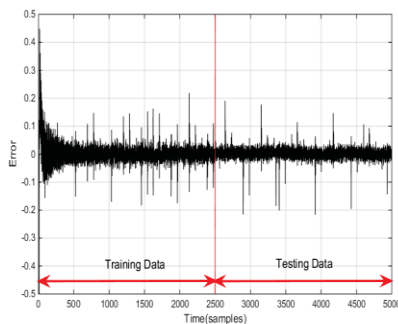

Fig. 6. Error between actual and estimated outputs of the system using RLS modelling.

Meanwhile, the correlation tests and pole zero diagram are plotted in Figs. 7 and 8, respectively. The correlation tests were carried out to determine the effectiveness of the developed model. For RLS algorithm, the model is biased as the results for auto correlation was observed over the 95% of confidence level. According to pole-zero diagram, the

developed model clearly show the stability of the system in RLS modelling as all the poles were located in the unit circle. The discrete transfer function obtained from the best model order as in Table 2.

TABLE III. DISCRETE TRANSFER FUNCTION FOR RLS MODELING

Transfer Function	
Numerator	Denominator
$a1 = -0.1084$	$b1 = -0.2862$
$a2 = 0.0625$	$b2 = -0.1016$
$a3 = 0.1415$	$b3 = 0.02019$
$a4 = -0.03345$	$b4 = 0.07373$
$a5 = -0.3125$	$b5 = 0.06755$
$a6 = -0.4341$	$b6 = -0.02379$

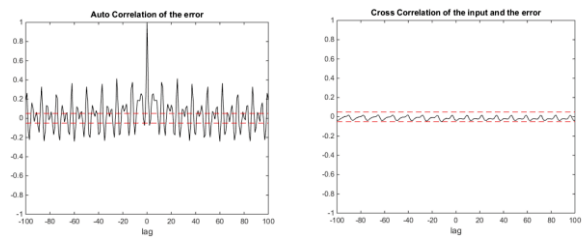

(a) (b)

Fig. 7. Correlation tests for RLS modelling: (a) Auto correlation, (b) Cross correlation.

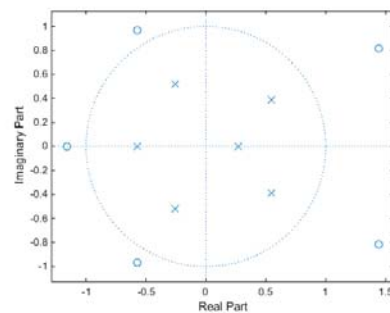

Fig. 8. Pole-zero diagram of the system using RLS modelling.

B. Modelling using Flower Pollination Algorithm

The similar process was applied in obtaining the best model for FPA which is tuning the involved parameters which were population size, maximum generation, switch probability and model orders. Based on the parameters listed in Table 3, the best model order for the structure was found to be the second order. The lowest MSE achieved for FPA identification are 1.8347×10^{-5} and 5.3212×10^{-6} for training and testing data, respectively. Fig. 9 shows the plotted result for mean squared error versus the number of generations for FPA modelling. Next, Figs. 10 and 11 show the actual and predicted outputs for the system in time and frequency domains, respectively. It is proved that the developed model is able to imitate the measured outputs very well. Other than that, the error between actual and estimated output using FPA modelling is plotted in Fig. 12

TABLE IV. THE SET OF PARAMETERS USED FOR FPA MODELING

Parameters	Value
Maximum generation	1400
Population size	25
Switch probability, p	0.8
Model order	4
Number of parameters	8

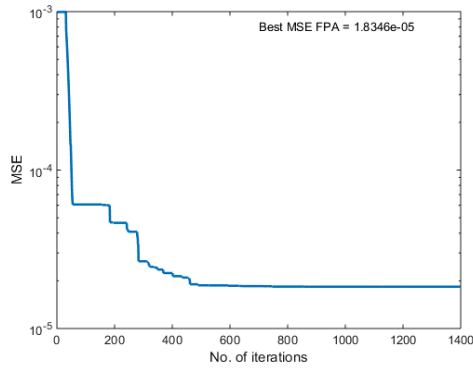

Fig. 9. Mean squared error versus the number of generation using flower pollination modelling.

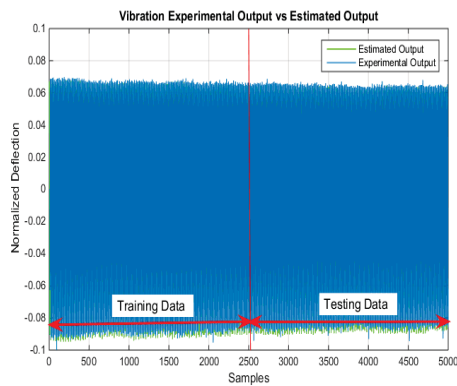

Fig. 10. Actual and prediction outputs of the system in the time domain using FPA modelling.

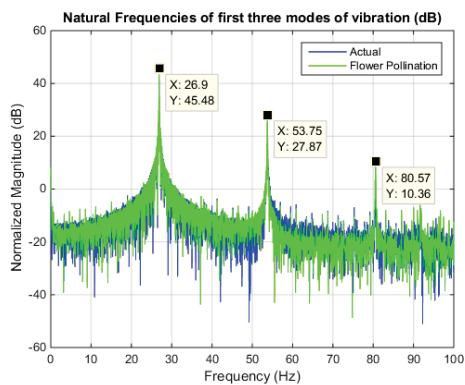

Fig. 11. Actual and prediction outputs in the frequency domain using FPA modelling.

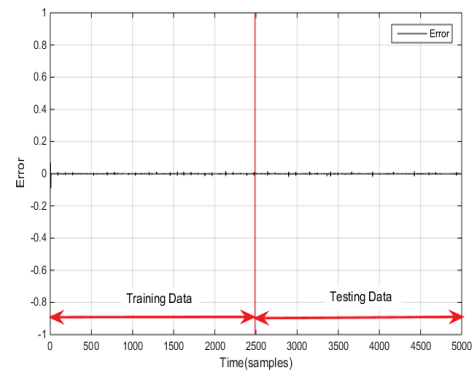

Fig. 12. Error between actual and estimated outputs of the system using FPA modelling.

Figs. 13 and 14 indicate the correlation tests and pole-zero diagram, respectively. The correlation tests are important as it is one of the validation to determine the effectiveness of the developed system. FPA modelling indicate that the obtained model is unbiased when the results were observed to be within the 95% confidence level. According to stability, the pole-zero diagram proved that all the poles were in the unit circle. The discrete transfer function obtained from the best model order for FPA modeling as in Table 4.

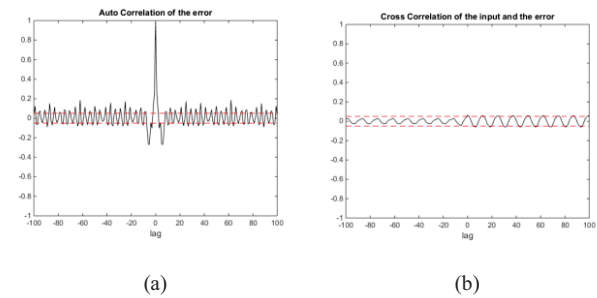

Fig. 13. Correlation tests: (a) Auto correlation, (b) Cross correlation.

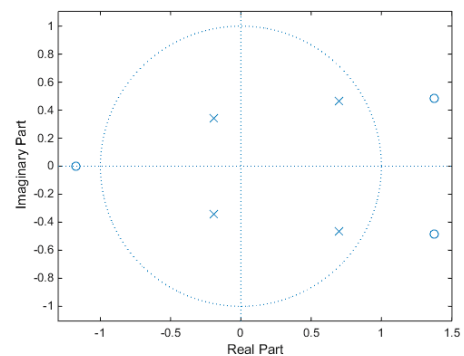

Fig. 14. Pole-zero diagram of the system using FPA modelling.

TABLE V. DISCRETE TRANSFER FUNCTION FOR FPA MODELING

Transfer Function	
Numerator	Denominator
$a1 = -0.2315$	$b1 = -1.01$
$a2 = 0.3649$	$b2 = 0.3248$
$a3 = 0.2546$	$b3 = 0.05497$
$a4 = -0.5764$	$b4 = 0.1078$

V. CONCLUSION

This paper had discussed on the dynamic response system represent flexible plate structure using system identification technique. The main objective of this study which is to develop mathematical model of horizontal flexible plate system via conventional and intelligent algorithm had achieved using recursive least square (RLS) and flower pollination algorithm (FPA). The mathematical model developed was validated by three methods which are lowest mean squared error, pole-zero stability and correlation tests within 95% of confidence level. The best developed model obtained must fulfil these criteria, thus it is approximately representing the horizontal flexible plate system and continue for vibration suppression of plate system. Based on this research, it was found that FPA had achieved to model the approximate flexible plate system and fulfil the criteria of validation which are lowest mean squared error, high stability and good correlation tests compared to RLS. RLS had achieved the best model in model order 12 but has biased in correlation tests in which in which not correlated up to 95% of confidence level. This correlation tests is important for effectiveness developed model validation. To be conclude, FPA has successfully represented the model of horizontal flexible plate system accurately.

ACKNOWLEDGMENT

The authors would like to express their gratitude to Minister of Education Malaysia (MOE), Universiti Teknologi MARA (UiTM), Universiti Malaysia Sarawak (Unimas) and Universiti Teknologi Malaysia (UTM) for giving the opportunities in conducting this research.

REFERENCES

- [1] Z. cheng Qiu, X. feng Wang, X. M. Zhang, and J. guo Liu, "A novel vibration measurement and active control method for a hinged flexible two-connected piezoelectric plate," *Mech. Syst. Signal Process.*, vol. 107, pp. 357–395, 2018.
- [2] C. Tang and X. Y. Lu, "Self-propulsion of a three-dimensional flapping flexible plate," *J. Hydrodyn.*, vol. 28, no. 1, pp. 1–9, 2016.
- [3] S. Yayla and S. Teksin, "Flow measurement around a cylindrical body by attaching flexible plate: A PIV approach," *Flow Meas. Instrum.*, vol. 62, no. May, pp. 56–65, 2018.
- [4] C. Zhang, J. Ma, X. Liang, F. Luo, R. Cheng, and F. Gong, "Fabrication of metallic bipolar plate for proton exchange membrane fuel cells by using polymer powder medium based flexible forming," *J. Mater. Process. Technol.*, vol. 262, no. February, pp. 32–40, 2018.
- [5] I. Z. M. Darus and A. A. M. Al-Khafaji, "Non-parametric modelling of a rectangular flexible plate structure," *Eng. Appl. Artif. Intell.*, vol. 25, no. 1, pp. 94–106, 2011.
- [6] A. A. M. Al-Khafaji, I. Z. M. Darus, and M. F. Jamid, "ANFIS modelling of flexible plate structure," 2010 1st Int. Conf. Energy, Power Control, vol. 6, no. 1, pp. 78–82, 2010.
- [7] A. I. Control, O. F. Vibration, O. F. Flexible, and P. Structures, "Active Intelligent Control of Vibration of Flexible Plate Structures," no. April, 2011.
- [8] M. S. Hadi, I. Z. Mat Darus, M. O. Tokhi and M. F. Jamid, "Active vibration control of a horizontal flexible plate structure using intelligent proportional-integral-derivative controller tuned by fuzzy logic and artificial bee colony algorithm," *J. Low Freq. Noise Vib & Actv Cont.*, vol. 0, no. 0, pp. 1-13, 2019.
- [9] M. S. Hadi, I. Z. M. Darus, R. T. P. Eek, and H. M. Yatim, "Swarm Intelligence for Modeling a Flexible Plate Structure System with Clamped-Clamped-Free-Free Boundary Condition Edges," 2014 IEEE Symp. Ind. Electron. Appl., no. January 2019, pp. 119–124, 2018.
- [10] M. S. Hadi and H. M. Yatim, "Modelling and control of horizontal flexible plate using particle swarm optimization Modelling and control of horizontal flexible plate using particle swarm optimization," no. January, 2018.
- [11] E. A. Ribeiro, E. M. de O. Lopes, and C. A. Bavastrri, "A numerical and experimental study on optimal design of multi-DOF viscoelastic supports for passive vibration control in rotating machinery," *Journal Sound and Vibration*, vol. 411, pp. 346–361, 2017.
- [12] N. Fadhilah, M. Ros, M. S. Saad, M. Z. Zakaria, and I. Z. M. Darus, "Modeling of Flexible Beam Using System Identification Approach," pp. 146–150, 2017.
- [13] A. Zippo, G. Ferrari, M. Amabili, M. Barbieri, and F. Pellicano, "Active vibration control of a composite sandwich plate," *Composite Structures*, vol. 128, pp. 100–114, 2015.
- [14] R. Wang, Y. Zhou, S. Qiao, and K. Huang, "Flower Pollination Algorithm with Bee Pollinator for cluster analysis," *Information Processing Letters*, vol. 116, no. 1, pp. 1–14, 2016.
- [15] R. Peesapati, V. Kumar, and N. Kumar, "Flower pollination algorithm based multi-objective congestion management considering optimal capacities of distributed generations," *Energy*, vol. 147, pp. 980–994, 2018.
- [16] A. Y. Abdelaziz, E. S. Ali, and S. M. A. Elazim, "Electrical Power and Energy Systems Combined economic and emission dispatch solution using Flower Pollination Algorithm," *International Journal of Electrical Power Energy System*, vol. 80, pp. 264–274, 2016.
- [17] M. Gao, J. Shen, and J. Jiang, "Optik Visual tracking using improved flower pollination algorithm," *Optic - International Journal Light Electron Optik*, vol. 156, pp. 522–529, 2018.
- [18] R. Salgotra and U. Singh, "Application of mutation operators to flower pollination algorithm," *Expert System with Applications*, vol. 79, pp. 112–129, 2017.