

The simulation analysis of piezoelectric transducer with multi-array configuration

Nik Ahmad Kamil Zainal Abidin¹, Norkharziana Mohd Nayan¹, M M Azizan¹, Azuwa Ali¹,
Nuriziani Hussin¹, N A Azli², N M Nordin²

¹Centre of Excellence for Renewable Energy (CERE), School of Electrical Systems Engineering, Universiti Malaysia Perlis, Pauh Putra Campus, 02600 Arau, Perlis, Malaysia.

²Power Electronics and Drive Research Group, School of Electrical Engineering, Universiti Teknologi Malaysia, 81310 Skudai, Johor, Malaysia

E-mail : norkharziana@unimap.edu.my

Abstract: Low frequency energy harvesting using piezoelectric is one of promising method on harvesting energy from a free source. This method offered powering low load and remote device application. However, due to its nature which is inconsistency in providing the magnitude of input, specifically in low frequency harvesting, better solution to stable up and increase the converted output is explored widely. There are a few parameter that influences in the piezoelectric output generation. These parameter includes the type of piezoelectric, piezoelectric array configuration, AC-DC converter and etc. The types of the piezoelectric used in this project are the circular piezoelectric. When there is a force (motion) exerted on the piezoelectric disk, electrical charge was produced which initiated the energy conversion. In this research, the configuration of array connection for piezoelectric were investigated. The system is tested with different load configuration in a range of 10 k Ω to 1 M Ω . The design and development of the piezoelectric array variant were series (S), parallel(P), series parallel (SP) and parallel-series (PS). The observation emphasized on finding the best types of piezoelectric array configuration in producing optimum output of the harvested power. The simulation part consists of designing, simulating and analysing the result are done by using PSIM software. For validation of the simulation result, the implementation design of the hardware prototype that supplies pressure to piezoelectric have been done. In conclusion, a proper implementation of piezoelectric array configuration will produce optimum power output which can fulfil the minimum requirement of energy for powering low load device.

1. Piezoelectric as energy harvesting device

Recent studies on development of energy harvesting device shows that a lot of work focused on developing systems that can optimized the harvested energy. The research work involved energy harvesting exploration aiming to increase the output power [1]–[4]. Apart from that, the developed systems are also have been tackled to made it portable and flexible, with the purpose that in can be placed at the road, rail, walkways, vibrating machines, and even on the human body. Difference approach on the harvesting design includes the circuit design, piezoelectric sensor configuration and its harvesting material have been take into account in order to optimize the amplitude of energy harvested [1], [2]. There is a concern over the lack of approach breakthrough in energy harvesting, thus it has become an obstacle to being adopted into technologies. This can be overcome with an approach of harvesting device optimization, which is capable to increase the power density of harvested energy in such a significant results. Therefore, the power density of a harvesting device can be significantly improved using appropriate method via device optimization. Apart from device optimization, there is another form of improving the power output of the device; which is through the manipulation of harvesting electrical circuit. It is often used to increase and stabilize the output power.

Basically, the piezoelectric sensor produced the vibration energy receiving from the surrounding. The energy from surrounding made a force toward at the surface of piezoelectric to generate vibration and at the same time, the piezoelectric sensor was work as a generator to convert the mechanical energy into electrical energy[5]–[7]. The material is very sensitive to a bending motion introduces when stress exist onto their surface There are many types of piezoelectric transducer in the market which are categorized according to its shapes, material build up and applications. The piezoelectric transducer change the kinetic energy produced from the mechanical vibration to an AC source[8]–[10]. Therefore an AC/DC converter circuit is required for storage purpose as most standalone application are using a DC power supply for operation. Depth exploration can be done upon the electronics circuit design which are voltage multiplier, AC/DC converter, and charging, the types of piezoelectric for optimal output, etc. Therefore, this research will focus on designing a suitable combination array of piezoelectric configuration circuit which extracting low frequency vibration in order to find the best piezoelectric sensor configuration to harvest a low frequency vibration energy.

Previous research has shown that low frequency application can be found in a source of vibration[11], [12], [3]. By using piezoelectric sensor, the vibration can be detected and converted into electrical energy. The potential of exploiting the low vibration frequency application is promising as the system can be implemented in any public place and the low vibration frequency source exists almost everywhere [10], [11], [13]–[15]. However, few problems encountered as the vibration are not consistent depending on the few factors such as pressure amplitude, frequency of the motion that touch the piezoelectric surface plate and its disk displacement. Furthermore, the circuit design in extracting the vibration is also crucial to ensure it stable, suitable and reliable with the piezoelectric and the vibration source consistency. Therefore, there is a significant issue in the search for suitable array configuration (series, parallel, combination) for circular piezoelectric to harvest an optimum low frequency vibration.

2. The piezoelectric transducer energy harvesting device system

Piezoelectric materials response applied mechanical stress with an accumulation of charge. Piezoelectric materials have been used to convert mechanical energy into electricity for many years [5], [7], [16]. Piezoelectric materials can be classify into several application such as sensor and actuator applications, spin valve devices, magnetoelectric material, energy harvesting applications, tissue engineering, modeling studies for PVDF and reversible 3D shape transformation of the PVDF and thin Film[17], [18].

The block diagram and equivalent circuit of the piezoelectric energy harvesting system shown in Figure 1. It consists of five main parts which are of a piezoelectric generator, AC-DC converter, DC-DC converter, energy storage device and a load. These system can be constructed and implemented using a different method in order to increase the system performance. Different block has specific function and operational to produce useful electricity. The first block is piezoelectric transduce, also known as a piezoelectric sensor. The piezoelectric sensor is functional to convert the vibration energy into electrical energy. The energy conversion will take place when the stress applied to the piezoelectric disk surface. The second block is the AC-DC converter circuit. The function of this block is to convert the AC source to the DC source using several types of AC-DC converter circuit. The third block is a DC-DC converter circuit that typically employs a DC-DC converter, mainly to match the source voltage with the battery charging level. The fourth block is storage that usually use a battery to store the charge from the source. Therefore, the charge stored in the battery could be used to energize and power the application.

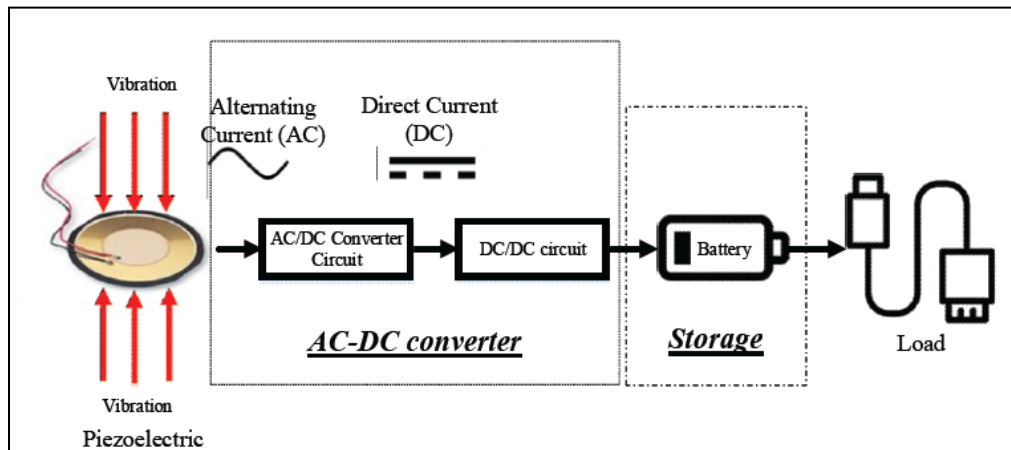

Figure 1 Basic block diagram of piezoelectric energy harvesting device

3. The multi-array configuration of piezoelectric sensor device.

The system starts with harvesting the vibration in a low frequency manner to the piezoelectric as shown in Figure 1. The piezoelectric changes the vibration energy to electrical energy. The current voltage form is in an AC voltage form. Therefore, the AC-DC converter circuit is needed to convert the generated AC to DC voltage form. At the harvesting stage, several types of topologies for array connection of piezoelectric are tested which are series, parallel, and combination series and parallel will be tested. Then the investigation on the output is done by observing optimum output with variant types of piezoelectric sensor array connection. Then the voltage will pass through the AC/DC converter circuit and DC/DC circuit before the extracted energy stores into the battery and utilized to the load.

Simulation of Array Configuration of the Piezoelectric Sensor

An array configuration of the piezoelectric is basically the arrangement of the piezoelectric sensor to increase the converter voltage, more than one piezoelectric sensor is used and arranged in specific array connection. Arrangement of several piezoelectric sensors in a specific structure can produce optimum energy which can be used to harvest the low-frequency vibration energy. There are four types of array connection used in harvest power from piezoelectric which is series, parallel, combination series and parallel and combination parallel and series.

The electrical output from piezoelectric can be determined from using the equivalent circuit shown in Figure 2. This circuit uses an AC current source, and an internal capacitance C_p represents a piezoelectric sensor. The displacement and frequency of the vibration affect the amplitude I_p of the current source. The current is represented as Eq. (1), where Eq. (2) and f_p is the frequency which the piezoelectric harvester is excited. The output power from the piezoelectric sensor was produced in AC source form that cannot be used directly for low load electronic device. Therefore, it needs to convert in DC source using the AC-DC converter circuit. The converting circuit should be able to extract the maximum power from piezoelectric energy harvester.

$$i_s = I_p \sin \omega_p t \quad (1)$$

$$\omega_p = 2\pi f_p \quad (2)$$

Then, a load resistor is used to perform an external circuit to the device which is for calculating the amount of power produced from piezoelectric harvester to the load. The design and construction of an efficient power conversion circuit is one of the challenges in a power generator to harvest the energy from the piezoelectric material. The internal impedance for piezoelectric generators is relatively high compared to the power supplies and batteries, which typically have very low internal impedance. This

problem reduce the amount of output current that can be produced by the piezoelectric source to the microampere range [4]. The value of I_s for simulation is obtained from hardware result using one unit piezoelectric experimental testing through $1\text{ M}\Omega$ resistance load. Besides that, the value of C_p is obtained from the datasheet piezoelectric model namely ABT-448-90-RC.

Table 1 Simulated parameter of piezoelectric.

Parameters	Value
Input Current	$1.36\ \mu\text{A}$
Voltage Input, V_{p-p}	2.68 V
Frequency	1 Hz
Load Resistance	$1\text{ M}\Omega$

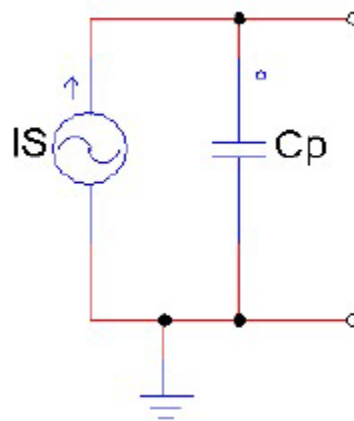

Figure 2 Modelling circuit of piezoelectric sensor

Types of Multi-Array Configuration for Piezoelectric

The first stage simulation piezoelectric sensor is done by connecting the piezoelectric sensor in parallel and series manner of the array configuration from one unit until 22 unit of the piezoelectric sensor. The purpose of this simulation is to estimate the expected output and characteristic of piezoelectric sensor with increment number of piezoelectric sensor in step size of one. Then, the simulation continued with utilization of three units of piezoelectric sensor connection with different types configuration circuits. Emphasis of this set of three piezoelectric sensor were investigated in this research because of to minimize the possibility of the series effect to the connection of piezoelectric sensor and to construct the minimum array connection of piezoelectric sensor configuration.

Table 1 show condition of piezoelectric when connected in series connection. Initial findings shows that if only one of the piezo is pressed out of three piezo in series connection, no output is recorded. If the piezo array is varied according to variation in the table below, the output is either decrease or no output at all. Therefore, a minimum of three pieces of piezo is adequate to test the various combination of series and parallel thus finding the best optimum output for further investigation.

The simulation continues by simulating a set of three piezoelectric sensor in four different types of configurations as Series configuration (S), Parallel configuration (P), Combination Series-parallel configuration (SP) and Combination Parallel- Series configuration (PS). Modelling of the piezoelectric sensor in series configuration connection is shown in Figure 3. Various load resistance (RL) value is used in measuring the performances of the device and the output power.

Table 2. Types of series effect in set of three piezoelectric sensor

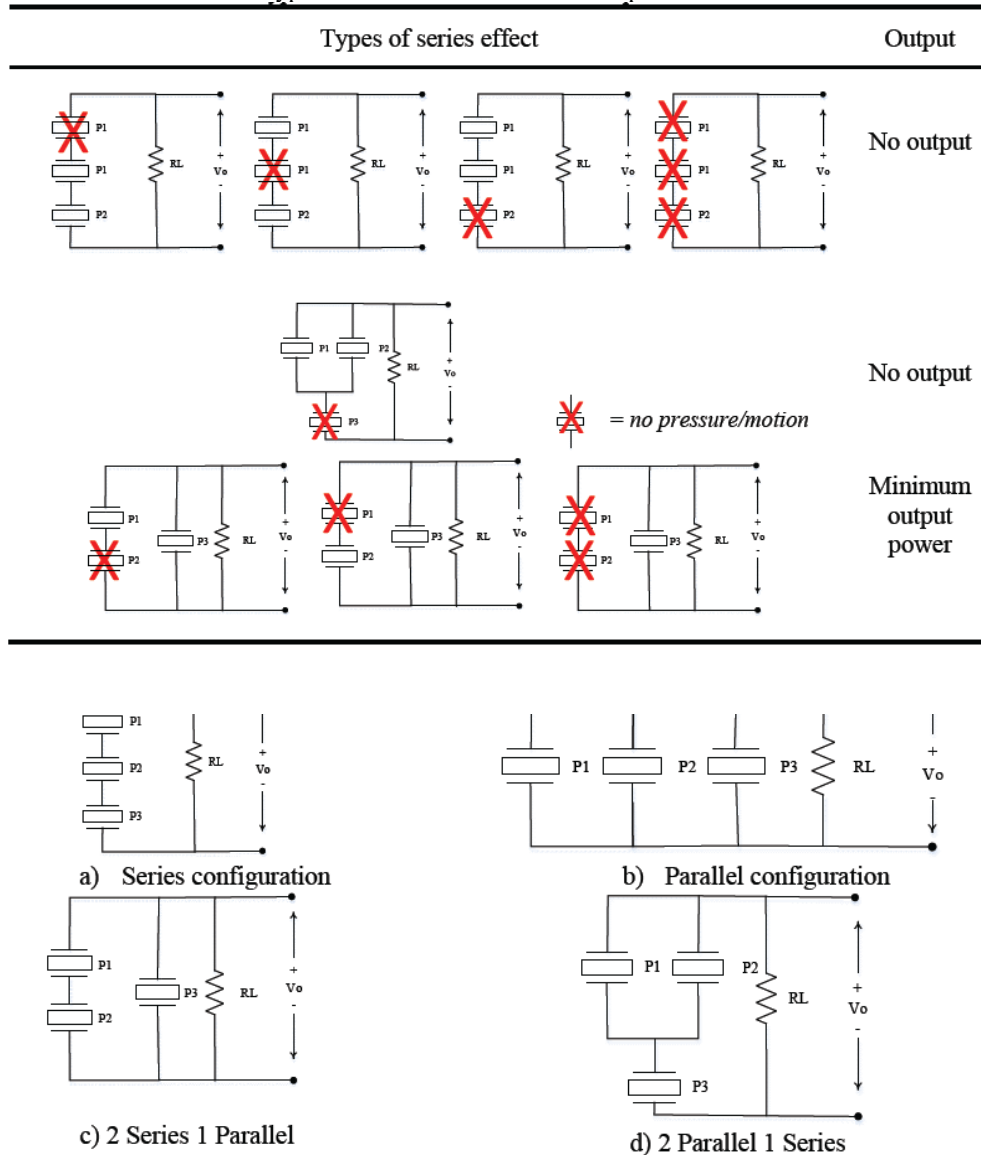

Figure 3 Configuration circuit of piezoelectric sensor connection

4. Simulation result

The simulated parameter of piezoelectric is shown in Table 1. This parameter values were collected from the hardware result by a motion device. The motion device was used to oscillate piezoelectric disk at a certain voltage output value with a repetitive motion. Table 2. Types of series effect in set of three piezoelectric sensor

Figure 4 shows the graph of number of piezoelectric sensors versus configuration of the sensor array in series and parallel across 1 MΩ load resistance. The output voltage was simulated at a fixed input current and frequency. The result shows that by increasing the number of the piezoelectric sensor, the resulting V_{rms} output voltage for series configuration is in similar magnitude of output from 1 units of piezoelectric to 22 unit of piezoelectric sensor. Meanwhile the V_{rms} output voltage for parallel configuration was increase exponentially with increasing the number of piezoelectric. The maximum output voltage for series configuration is lower than parallel configuration which is 1.36V and 5.95V for the later with total 22 unit piezoelectric sensor. The simulation is then continued with arrays three units piezoelectric configuration connected in series, parallel and combination between series and

parallel. Figure 5 shows the output voltage comparison of the variant types of array piezoelectric configuration graph with $1\text{ M}\Omega$ load resistor. The graph shows that with set of 3 unit of piezoelectric sensor with parallel configuration will produce highest voltage output as compared with other types of configuration.

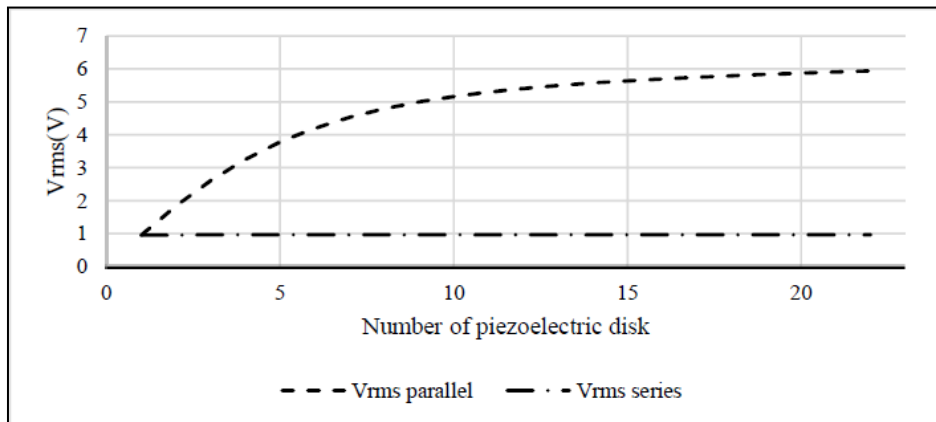

Figure 4 Number of sensor versus voltage output in series and parallel array configuration

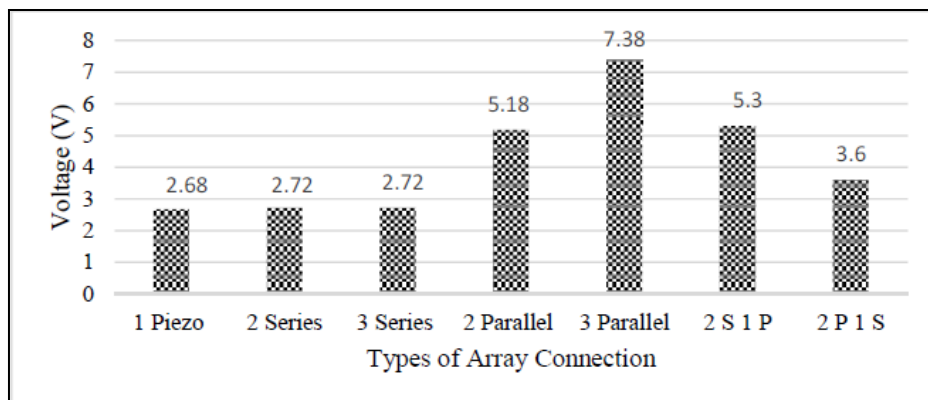

Figure 5 Output voltage comparison of the variant types array configuration with 3 unit of piezoelectric sensor

Simulation result for series piezoelectric configuration

The simulation of piezoelectric array configuration continued in series connection. Investigation were done to observe the voltage output under various value load resistances ranging from $10\text{ k}\Omega$ to $1\text{ M}\Omega$. The connection is done by connecting set of piezoelectric in series configuration; 1 unit of piezoelectric in series, 2 units of piezoelectric configuration in series and array of 3 units of piezoelectric configuration in series. The graph shows that from $10\text{ k}\Omega$ to $1\text{ M}\Omega$ load resistance the output voltage increases linearly with the load resistance value. There is no distinct difference in voltage output between the slope of the graph when piezoelectric are connected in series as compared to the maximum voltage output produced by one unit of piezoelectric disk. The one-unit piezoelectric disk produced maximum V_{rms} of 0.95V at $1\text{ M}\Omega$ and for the two series piezoelectric connection was produced maximum V_{rms} of 0.96V . While three series piezoelectric connection was produced maximum voltage also at 0.96V . It is found that, the increment number of piezoelectric sensors does not affect the amplitude of the voltage output. This same voltage output is due to the current source are connected in series connection. When the current sources are connected in series, the output voltage would be generated at the same output although adding the several current sources.

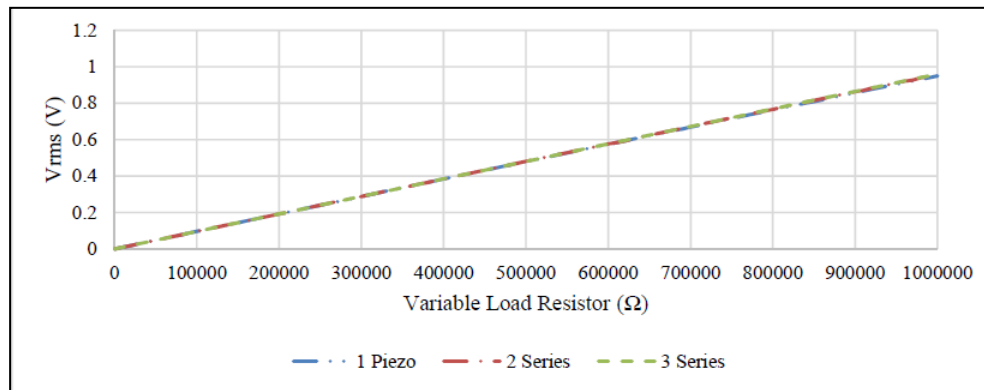

Figure 6 Output voltage using a series array configuration of a piezoelectric sensor

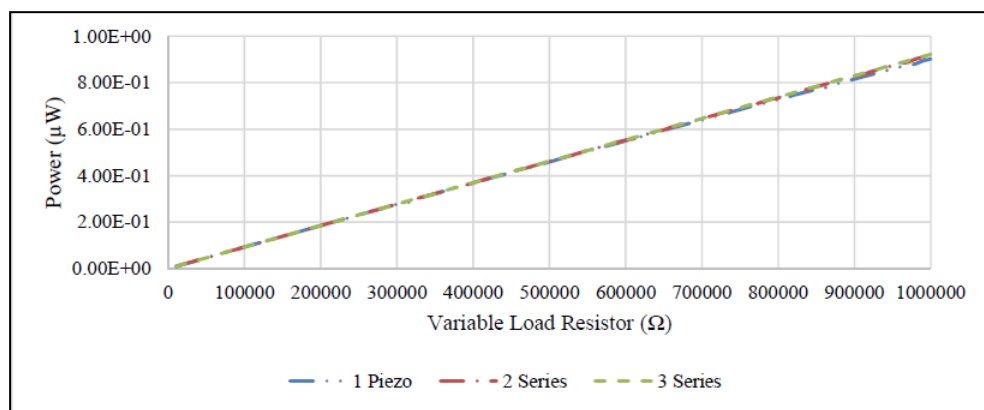

Figure 7 Output power using a series array configuration of piezoelectric sensr

However, in series connection, the current output is expected to be lower and this would definitely affect the power output of the connected piezoelectric. Based on the result obtained in Figure 6 and Figure 7, the value is converted into power output, the different maximum value shown in each graph. The power generated is optimum at $0.90\mu\text{W}$ for single piezoelectric connection during $1\text{M}\Omega$ load resistance. Meanwhile for 2 series connection and 3 series connection of piezoelectric which are same as $0.92\mu\text{W}$. The same value of maximum power is due to the fact that current source value when connected in series because of the coupling effect from the internal capacitance piezoelectric. Due to the fact that piezoelectric is a conservative device, the charge produced by the piezoelectric is indirectly effect and will be dissipated through another conservative piezoelectric as there is no isolation between the piezoelectric when connected together in series connection. Therefore adding more piezoelectric in series is not helpful in term of gaining the power output since it will produce same the power level.

Simulation result for parallel piezoelectric configuration

The piezoelectric array configuration in parallel connection as can be seen in Figure 3(b) results in voltage output as shown in Figure 8 while the result for its power value is shown in Figure 9. The V_{rms} output with three types of array connection increase linearly with increasing the load resistance from $10\text{ k}\Omega$ to $1\text{ M}\Omega$. The maximum output voltage achieved by using 3 parallel piezoelectric connection is 2.61V and for 2 unit in parallel connection and the single piezoelectric connection is 1.84V and 0.94 . Simulation results of total voltage for two and three parallel piezoelectric connection voltage slightly increases than single piezoelectric. The total power of the circuit was increasing proportionally to the load resistance when the power source is connected in parallel. This is shown in Figure 9, there are difference degree of slope with increment of connection of piezoelectric sensor and its array configuration. The power output increase in double for two and triple for three piezoelectric sensor connection which is $3.37\mu\text{W}$ and $6.81\mu\text{W}$ compare to a single piezoelectric connection is $0.90\mu\text{W}$ at $1\text{ M}\Omega$.

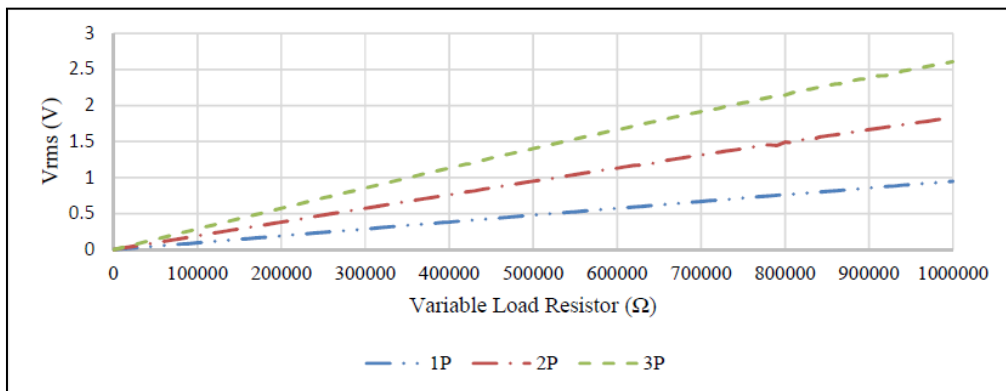

Figure 8 Output rms voltage using parallel array connection of piezoelectric simulation

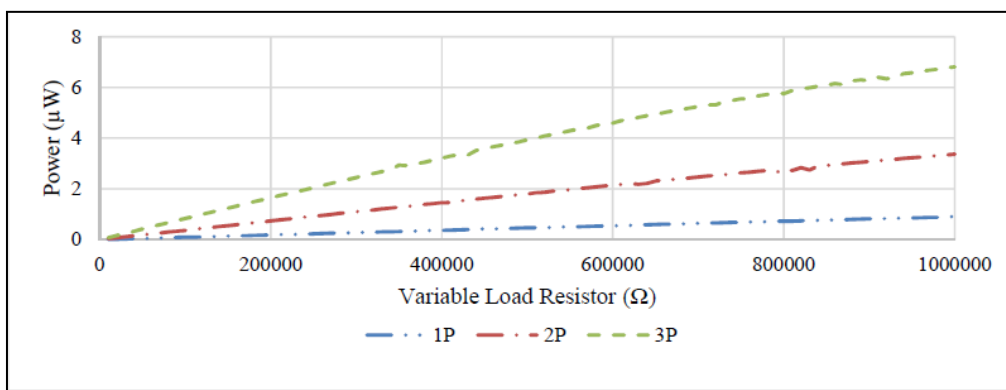

Figure 9 Output power using parallel array connection of piezoelectric simulation

Simulation result using a combination of series and parallel piezoelectric connection

The combination of piezoelectric array configuration in series and parallel connection is observed within a range of 1 MΩ resistances. The simulation result of voltage output is shown in Figure 10, while the simulation result for its power value in shows in Figure 11. It can be seen that, the combination between array piezoelectric connection affect the harvested output voltage in positive manner rather than using single piezoelectric sensor. The Vrms output increases linearly with load resistor from 10 kΩ to 1 MΩ. In the same time, compared with single piezoelectric sensor, the maximum voltage outputs obtained from the combination array connection of piezoelectric are much higher. 1.87Vrms maximum obtained for 2S1P piezoelectric connection and 1.28Vrms for 2P1S piezoelectric connection. However, the voltage value is not as high as compared to the voltage result obtained from the series piezoelectric connection. Same goes to its output power value, it is higher compared to the power produced by series and parallel piezoelectric connection, in which 2S1P piezoelectric connection produced a maximum power of 3.50 μW and 2P1S piezoelectric connection produced a maximum power of 1.63μW at 1 MΩ load resistor.

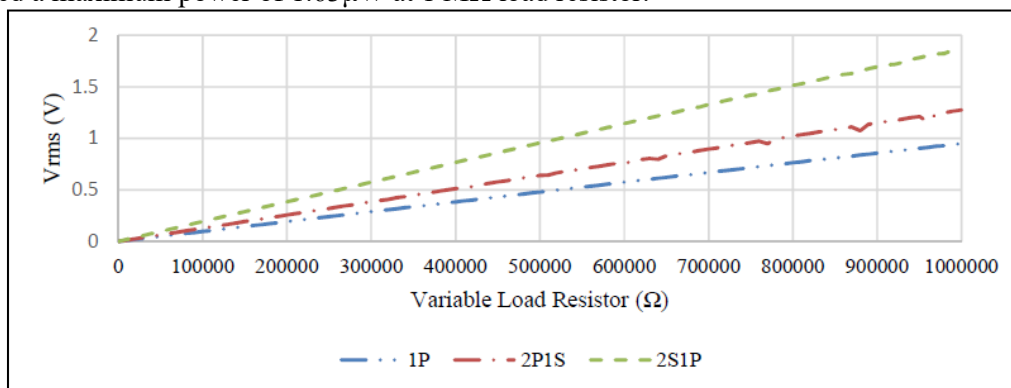

Figure 10 Output voltage using combination array connection of piezoelectric simulation

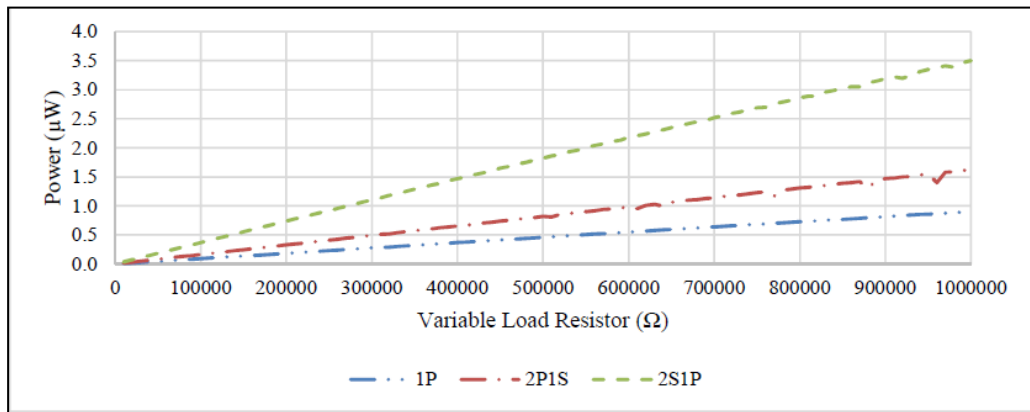

Figure 11 Output power using combination array connection of piezoelectric simulation

5. Conclusions

The simulation analysis of piezoelectric sensor simulation have been done in order to observe its performance using PSIM software. The simulation is done for set of an array of piezoelectric sensor configuration in finding the best configuration to maximize the output as compared to one piezoelectric sensor. An equivalent circuit is used to represent the piezoelectric sensor in simulation which consists of current source and capacitor (internal capacitance). The value of capacitor affects the harvesting output as in on each configuration. From the simulation, it is concluded that the maximum number of piezoelectric of 22 unit will makes the Vrms output will remain constant even the number of piezoelectric sensor is added.

Then by varying the piezoelectric configuration with 3 unit piezoelectric sensor, there were significant impact of the output can be found. Piezoelectric sensor configuration combination with series and parallel (2S1P and 1S2P) connection the output for parallel is the highest by 28.63% and 51.15%. In order to harvest optimum output from kinetic or vibration energy with piezoelectric sensor, emphasis need to be done in design stage of its configuration circuit. Different types of configuration will give difference level of output. Apart from that, from the experimental results, it can be seen that the piezoelectric sensor need to received even pressure of motion in order to gain maximum output. Design circuit also need to be in line with types of energy harvesting end application as different application will limits the requirement of its energy harvesting conditioning circuit. High voltage gain can be further obtained by connecting the harvesting circuit with appropriate rectifier and/or inverter circuits.

References

- [1] H. Jabbar, S. D. Hong, S. K. Hong, C. H. Yang, S. Y. Jeong, and T. H. Sung, "Sustainable micropower circuit for piezoelectric energy harvesting tile," *Integr. Ferroelectr.*, vol. 183, no. 1, pp. 193–209, Sep. 2017.
- [2] "Road energy harvester designed as a macro-power source using the piezoelectric effect," *Int. J. Hydrog. Energy*, vol. 41, no. 29, pp. 12563–12568, Aug. 2016.
- [3] A. Daniels, M. Zhu, and A. Tiwari, "Evaluation of piezoelectric material properties for a higher power output from energy harvesters with insight into material selection using a coupled piezoelectric-circuit-finite element method," *IEEE Trans. Ultrason. Ferroelectr. Freq. Control*, vol. 60, no. 12, pp. 2626–2633, Dec. 2013.
- [4] "An Efficient Piezoelectric Energy Harvesting Interface Circuit Using a Bias-Flip Rectifier and Shared Inductor - IEEE Journals & Magazine." [Online]. Available: <https://ieeexplore.ieee.org/document/5357551>. [Accessed: 08-Jul-2019].

- [5] R. Calìo et al., “Piezoelectric Energy Harvesting Solutions,” *Sensors*, vol. 14, no. 3, pp. 4755–4790, Mar. 2014.
- [6] M. Zhang and J. Wang, “Experimental Study on Piezoelectric Energy Harvesting from Vortex-Induced Vibrations and Wake-Induced Vibrations,” *J. Sens.*, 2016.
- [7] W. Tian, Z. Ling, W. Yu, and J. Shi, “A Review of MEMS Scale Piezoelectric Energy Harvester,” *Appl. Sci.*, vol. 8, no. 4, p. 645, Apr. 2018.
- [8] D. Kumar, P. Chaturvedi, and N. Jejurikar, “Piezoelectric energy harvester design and power conditioning,” in *2014 IEEE Students’ Conference on Electrical, Electronics and Computer Science (SCEECS)*, 2014, pp. 1–6.
- [9] D. Vasic and Y. Yao, “PWM interface for piezoelectric energy harvesting,” *Electron. Lett.*, vol. 49, no. 13, pp. 843–845, Jun. 2013.
- [10] J. Hu, J. Jong, and C. Zhao, “Vibration energy harvesting based on integrated piezoelectric components operating in different modes,” *IEEE Trans. Ultrason. Ferroelectr. Freq. Control*, vol. 57, no. 2, pp. 386–394, Feb. 2010.
- [11] “A study of low level vibrations as a power source for wireless sensor nodes,” *Comput. Commun.*, vol. 26, no. 11, pp. 1131–1144, Jul. 2003.
- [12] “A low-frequency piezoelectric-electromagnetic-triboelectric hybrid broadband vibration energy harvester,” *Nano Energy*, vol. 40, pp. 300–307, Oct. 2017.
- [13] J. Liang and W.-H. Liao, “Energy harvesting and dissipation with piezoelectric materials,” in *International Conference on Information and Automation, 2008. ICIA 2008, 2008*, pp. 446–451.
- [14] D. F. Berdy, P. Srisungsitthisunti, B. Jung, X. Xu, J. F. Rhoads, and D. Peroulis, “Low-frequency meandering piezoelectric vibration energy harvester,” *IEEE Trans. Ultrason. Ferroelectr. Freq. Control*, vol. 59, no. 5, pp. 846–858, May 2012.
- [15] “High-Performance Piezoelectric Energy Harvesters and Their Applications,” *Joule*, vol. 2, no. 4, pp. 642–697, Apr. 2018.
- [16] Z. Wang, X. Pan, Y. He, Y. Hu, H. Gu, and Y. Wang, “Piezoelectric Nanowires in Energy Harvesting Applications,” *Adv. Mater. Sci. Eng.*, 2015.
- [17] “The Piezoelectric Effects and Its Applications,” Tacuna Systems. [Online]. Available: <https://tacunasystems.com/knowledge-base/force-measurement-tips/the-piezoelectric-effects-and-itsapplications/>. [Accessed: 08-Jul-2019].
- [18] D. Koyama and K. Nakamura, “Electric power generation using a vibration of a polyurea piezoelectric thin film,” in *2008 IEEE Ultrasonics Symposium, 2008*, pp. 938–941.