

PAPER • OPEN ACCESS

## Design and control of a motor wheel system controlled by smartphone

To cite this article: Z Asus *et al* 2020 *IOP Conf. Ser.: Mater. Sci. Eng.* **884** 012097

View the [article online](#) for updates and enhancements.



**ECS** **240th ECS Meeting**  
Digital Meeting, Oct 10-14, 2021  
**We are going fully digital!**  
Attendees register for free!  
**REGISTER NOW**

# Design and control of a motor wheel system controlled by smartphone

**Z Asus<sup>1,7</sup>, M F I Mat Razi<sup>2</sup>, M F Mahmudin<sup>3</sup>, Z H Che Daud<sup>4</sup>, I I Mazali<sup>5</sup> and M I Ardani<sup>6</sup>**

<sup>1,2,3</sup> Department of Applied Mechanic and Design, School of Mechanical Engineering, Faculty of Engineering, Universiti Teknologi Malaysia, 81310 Johor Bahru, Johor, MALAYSIA.

<sup>4,5,6</sup> Department of Aeronautics, Automotive, and Ocean Engineering, School of Mechanical Engineering, Faculty of Engineering, Universiti Teknologi Malaysia, 81310 Johor Bahru, Johor, MALAYSIA.

<sup>1,4,6</sup> Automotive Development Centre, School of Mechanical Engineering, Faculty of Engineering, Universiti Teknologi Malaysia, 81310 Johor Bahru, Johor, MALAYSIA.

E-mail: zainabasus@utm.my, fikri.irsyad.samura@gmail.com, fazzlan@gmail.com, hilmi@mail.fkm.utm.my, izhariizmi@utm.my, ibthisham@utm.my

**Abstract.** The purpose of this project is to design a wheel system controlled by smartphone for multiple utilisations and determine its efficient control. The motor wheel system is equipped with four mecanum wheels with ten movements: forward, reverse, left, right, clockwise, counter-clockwise, and four on diagonal. PID control which is a closed-loop control was implemented to regulate the speed of the wheel system. The system is equipped with Bluetooth and a mobile application was developed as its user interface. Two control mode was developed in this project which is the precision mode where the user controls the wheel system manually using the smartphone as a control panel and another mode is the following mode where smartphone internal gyroscope and accelerometer are combined together to move the wheel system automatically with respect to the user body movements. CAD model of the design is developed in Solidworks and finite element analysis is done using CAE. FEA analysis is studied and discussed with focus on the critical location of the design. The full-size prototype of the design is developed and tested in normal running conditions. The system is proven to be reliable to carry loads and can be controlled efficiently by smartphone.

## 1. Introduction

A motor-driven wheel system consists of an electric DC motor connected to a wheel through direct or indirect medium. On the other hand, wheel system controlled by an on-board controller can be categorized as robot. A robot is defined as a machine controlled by a computer that is used to perform task automatically [1, 2]. Autonomous guided vehicles (AGVs) are mobile robots that can move autonomously on the ground within indoor or outdoor environments while performing a set of tasks [3]. Autonomous mobile robot (AMR) is very similar to AGV, but instead of having a guidance system to navigate the AMR navigates via maps that its software constructs on-site or via pre-loaded

<sup>7</sup> To whom any correspondence should be addressed.



facility drawings [4, 5]. This project falls under the AMR category where the robot is fully controlled using a smartphone instead of any plan guidance system.

A control system manages, commands, and regulates the behavior of a device to achieve a specific task or to suit its sole function [6, 7]. A controllable wheel system has been widely used in various fields such as military, agriculture, industrial and even household appliances. Generally, a wheel system is used to carry huge amount of load or mount other sub-systems that perform a specific task on top of it [8, 9]. Wheel system also been used to navigate in hostile environments such as warzone, high radiation places, extreme heat and also high-pressure conditions such as in a deep-sea environment to carry out a mission or task [8, 10].

Smartphones have been used for many applications such as drones and smartwatch [11]. One method to control a wheel system via smartphone is through a wireless Bluetooth medium. For that, a smartphone application needs to be created as a remote control for the wheel system. A simple arrow such as up, down, left, right and et cetera graphic user interface (GUI) can be used as precision control for the wheel system. On the other hand, a built-in accelerometer and gyroscope in the smartphone can be implemented to be used as following mode for the wheel system. In this project, the wheel system will use a four-wheel-drive transmission pack together in a rigid chassis structure driven by a motor driver controlled by Arduino and using a Li-po battery as the power source.

## 2. Motor wheel system design

In designing a motor wheel system suitable for multiple utilisations, there are several design specifications that have to be followed. The objective is for the system to be able to carry heavy load of up to 100 kg without fail with a steady speed for all range of load. The structure should have an ample safety factor to carry on with its function and without any apparent deformation. And lastly, the control using the smartphone should be reliable and can give the intended trajectory for all possible movements.

### 2.1. Mecanum wheels

The mecanum wheel is an Omni-directional wheel concept designed by Bengt Ikon in 1973. The design consists of a series of rollers placed at an angle of  $45^\circ$  [5]. The implementation of the mecanum wheels allows the robot to move in the Omni-directional movement without needing a conventional steering, making it possible for the robot to move sideways without changing the orientation of the robot. The angle of the roller is the key to the force vector for each wheel, a set of four wheels of different force vector direction are combined to produce the desired total force vector of the robot as illustrated in Figure 1a).

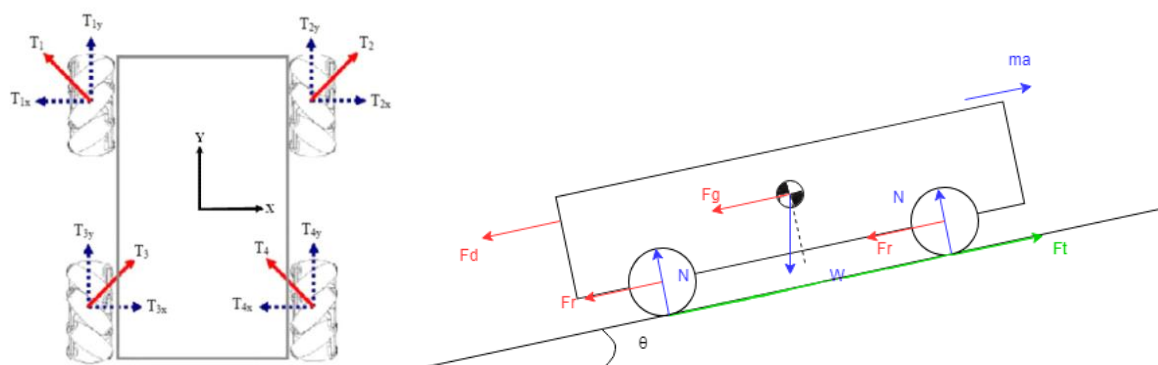

**Figure 1. (a) Mecanum force vector and (b) Free body diagram of the motor wheel system.**

### 2.2. Torque calculation

The primary criterion of designing a robot that carries load is to calculate the torque required to transmit the weight of the load from one point to another. Torque calculation is done for each gross weight from 10 kg to 100 kg with actual working condition assumption shown in figure 1(b). Torque required for the system is calculated using the total tractive effort,  $F_t$  of the system as in equation 1. Where  $ma$  is the equivalent inertial force,  $F_r$  is the rolling resistance,  $F_g$  is the gradient resistance and  $F_d$  is aerodynamic drag. The aerodynamic drag of the system is neglected due to an insignificant value. Torque at each wheel,  $T$  are in function of the total tractive effort and the wheel's effective radius,  $R$  divided by the number of wheel,  $n$ .

$$F_t = ma + F_r + F_g + F_d \quad (1)$$

$$T = F_t R / n \quad (2)$$

### 3. Control mode

There are two control methods developed for this wheel system. The first method is precision mode and the other method is the following mode. Smartphone is used to act as the remote control for this wheel system through a smartphone application. The wheel system was also implemented with PID control to regulate the speed for better control.

#### 3.1. Precision mode

In the precision control method, the wheel system is programmed to move in 10 directions which are forward, reverse, left, right, left-up diagonal, left-down diagonal, right-up diagonal, right-down diagonal, clockwise and counter-clockwise. In the application, there will be 10 arrow buttons for each direction. Figure 3 shows the smartphone application.

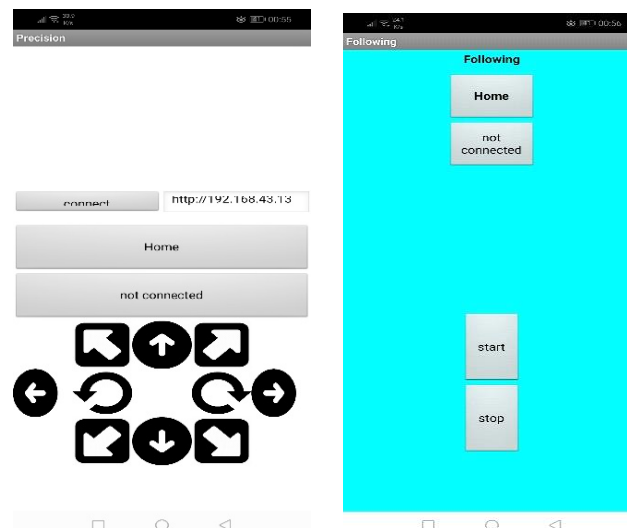

**Figure 3.** The smartphone mobile application graphical user interface.

Figure 4 shows the flow of the precision control. Starting with the input, the user will give the direction to move. The smartphone apps will then give the signal to Arduino via Bluetooth communication which later will be received by the Arduino which finally control the motor by signalling the motor driver.

### Precision Control

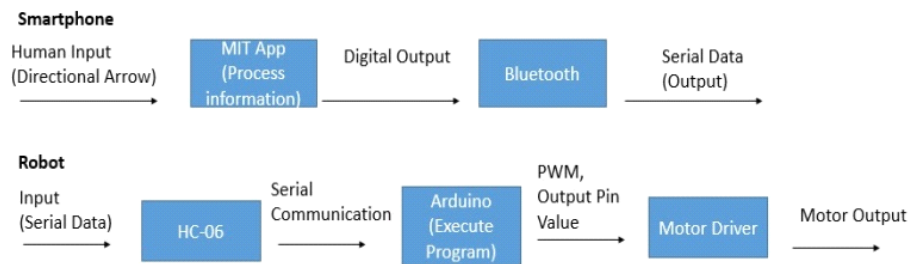

**Figure 4.** The control process flow for the precision mode.

### Following control

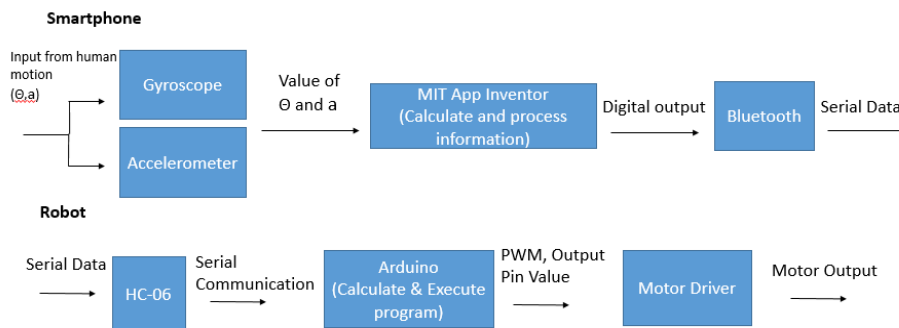

**Figure 5.** The control process flow for the following mode.

### 3.2. Following mode

In the following control method, the wheel system is programmed to follow the user movement and motion whenever the user walking. This can be done by taking advantage of the micro-electromechanical system (MEMS) sensors in the user's smartphone. The control flow is as shown in figure 5. Referring to figure 3, the application interface for the following mode has no arrow button but only a start and stop button. The start button will make the wheel system follow the user, while the stop button is for stopping the following action. This will make the wheel system stay still. Gyroscope in the MEMS sensor can detect the angular velocity caused by orientation changes made by the user. This mechanism is used to tell the apps if the user is changing his orientation. In order to detect a forward movement, the accelerometer built in the smartphone is used. Whenever a user moves forward, he will produce an acceleration that will be detected by the accelerometer. The accelerometer will then tell the wheel system to move forward as long as the user is moving and will stop as soon as the user stop moving.

### 3.3. Speed control

A proportional–integral–derivative (PID controller) is used to control the speed control. The purpose of utilizing PID control in the wheel system is to ensure the wheel system moves at a fixed speed. In no-load condition, the wheel system can move at high speed without problem. But as the load increases, the speed of the wheel system will be slower. One of the solutions is to set the motor output to its maximum level so that at the maximum carrying capacity, the wheel system will still move with the designated speed. But, by setting the motor output at maximum value at all times will make the wheel system hard and difficult to control in no load condition. The wheel system will be highly uncontrollable and will cause damage to the wheel system motor gearbox and also pose safety hazard

to its surrounding. The best solution is to use a PID control so that the wheel system speed is regulated according to its carrying load. When the wheel system is slowing down due to heavy loads, the PID control will compensate the slow movement by raising the motor output level. Figure 6 shows the PID block diagram for the wheel system.

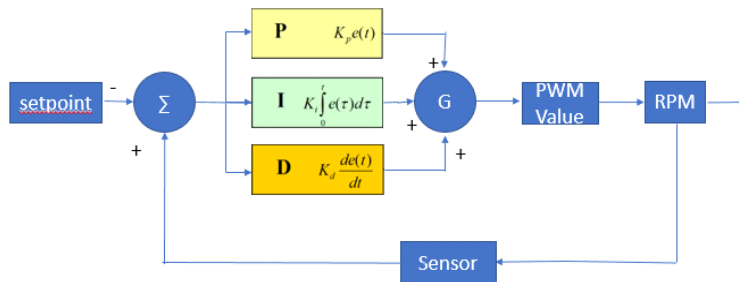

**Figure 6.** The PID block diagram to control the speed of the motor wheel system.

#### 4. Results and discussion

There are two results to be presented and discussed in this section. The first result is the PID control. The PID value has been tuned manually by minimizing the time delay for the system to reach the desired speed and limiting the power overshoot. For the PID control, a graph of the pulse width modulation (PWM) and speed in round per minute (RPM) for the wheel speed was plotted to see the relationship between the two parameters. The other result is the engineering analysis. The CAD model of the design is built in complete detail with the mechanical properties of each material assigned as it will be used to run the engineering analysis. A full-scale working prototype is then developed for physical testing and demonstration. Table 1 shows the torque needed at each wheel at different loads.

**Table 1.** Required motor torque at each wheel.

Gross mass (kg)	Torque (Nm)	Torque per wheels (Nm)	Motor Torque (Kgcm)
10	1.400	0.350	3.567
20	2.800	0.700	7.135
50	6.999	1.750	17.837
70	9.799	2.450	24.971
100	13.998	3.500	35.673

##### 4.1. PID control

Figure 7 shows the overlapped graph of the motor speed and PWM versus time. In the graph, the speed and PWM is inversely proportional to each other. As the speed drops, the PWM level rise and it will drop if the speed rise. This is due to the fact that for the power given depends on its speed and torque needed at an instant which explains the ups and downs in the graph, where the torque needed is translated as the PWM. Figure 7 also concludes that the PID controller system is working. The compensation of the PWM level due to slowing down of the wheel rotation is done simultaneously according to the load it carries.

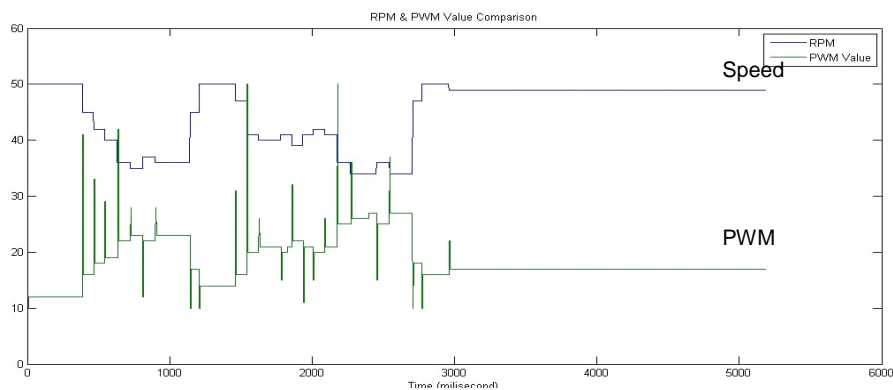

**Figure 7.** Graph of the motor wheel system speed and PWM versus Time in milliseconds.

#### 4.2. Engineering analysis

To understand the structural performance of the design, Solidworks simulation is used to execute the finite element analysis (FEA). The FEA method predicts a product's real-world physical behavior by virtually testing CAD models with a set of defined environments similar to the real-world environment. Attention of the FEA results is focused on critical areas where the component most likely to break. A quarter model of the design is analyzed with an operating load of 100 kg and fixed geometry constraint at each surface in contact with the wheel assuming that the load at the surface is taken fully by the wheels. The results of the analysis are as follows: Maximum stress of the design is located at the contact of the edge of the top support and the top plate platform with a value of 118.1 MPa. All of the FEA analysis leads to factor of safety results where it helps to understand why and where the design will fail.

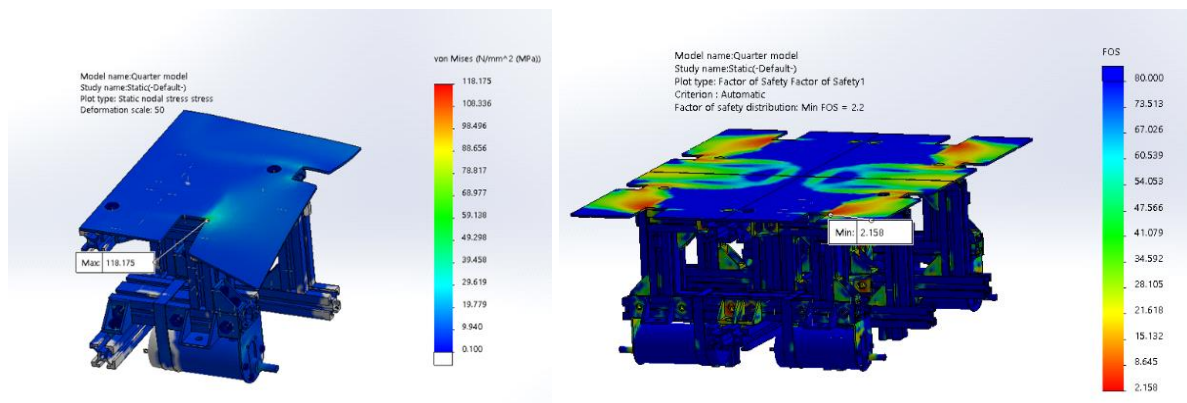

**Figure 8.** FEA results of the system for (a) Maximum stresses and (b) Safety factor.

According to the result obtained from the FEA, the safety factor is determined to be 2.16. Based on recommendation by R. Juvinall, the safety factor for materials operated in an ordinary environment with load and stresses that can be determined is recommended to be between 2 to 2.5 [1]. And the safety factor for the design is in the recommended range. The maximum deformation of the structure is situated at its end corners with 0.65 mm deformation. This small deformation will not affect the function of the system nor will it intervene with movement of the wheels. Apart from the FEA, the other analysis that has been done is on the material selection and motor type determination. The usage of aluminium instead of carbon steel significantly reduces the weight of the system. And, the motor chosen delivers much more torque that enables the system reliable to carry heavier weight.

## 5. Conclusion

In conclusion, the wheel system is able to move in four-axis which translated to ten movements that are, forward and reverse, rotation clockwise and counter-clockwise, sideways left and right and diagonally left-up, left-down, right-up and right-down. With PID control, this wheel system can move at a fixed speed at any amount of loads that the wheel system is carrying. The speed can be set as desired. The wheel system can be controlled with two modes which are precision mode and the following mode. The design achieves the objective of having a reliable design that is small and compact, light, high in no-load speed and high maximum load. The additional features added gives operational value advantage, the omnidirectional drive significantly improves the mobility of the robot, modularity features enable a user to attach modified parts to the robot and aluminium profiles are easy to be replaced without professional assistance. Overall, the objective of this study has been achieved. In the future, the smartphone application can be updated to be more user-friendly and have a fresh looking user interface.

## Acknowledgments

The authors would like to thank the Ministry of Education (MoE) and Universiti Teknologi Malaysia (UTM) for funding this research and also UTM Research Management Centre (RMC) for managing the research activities under vote no. Q.J130000.3551.07G10.

## References

- [1] Juvinal R C and Marshek Kurt M 2017 *Fundamentals of machine component design*
- [2] Kim M and Choi D 2019 *Design and development of a variable configuration delivery robot platform (International Journal of Precision Engineering and Manufacturing)* p 1757-1765
- [3] Klančar G, Zdešar A, Blažič S, and Škrjanc I 2017 *Wheeled Mobile Robotics* (Kidlington: Butterworth-Heinemann.)
- [4] Mohd Salih J E, Rizon M, and Yaacob S 2006 *Designing Omni-Directional Mobile Robot with Mecanum Wheel (American Journal of Applied Sciences)*
- [5] Annusewicz A 2019 *The use of vision systems in the autonomous control of mobile robots equipped with a manipulator* (Transcom 2019)
- [6] Schlee K L and Schlee B A 2013 *Mecanum wheel* (United States)
- [7] Siegwart Roland and Nourbakhsh I R 2004 *Introduction to Autonomous Mobile Robots (Robotica 2nd ed. Vol. 23)* (Cambridge: The MIT Press)
- [8] David Pierce 2017 *The Cute Robot That Follows You Around And Schleps All Your Stuff*. Retrieved from <https://www.wired.com/2017/02/piaggio-gita-drone/> [September 2018]
- [9] Yang Q, Qu D, Xu F, Zou F, He G and Sun M 2018 *Mobile robot motion control and autonomous navigation in GPS-denied outdoor environments using 3D laser scanning (Assembly Automation, Emerald Publishing Limited)* p 469-478
- [10] Tiago T R and Conceicao A G S 2019 *Nonlinear model predictive visual path following control to autonomous mobile robots (Journal of Intelligent and Robotics Systems)* p 731-743
- [11] Elena G P and Yulia V R 2019 *Results, Industry 4.0: Industrial Revolution of the 21st Century* (Cham Switzerland. Springer International Publishing AG) p 13-18