

PAPER • OPEN ACCESS

Potential Review on Energy Analysis Attributes for in 6 Dimension Application in Building Information Modelling (BIM)

To cite this article: Abdul Hadi Ahamad *et al* 2020 *IOP Conf. Ser.: Earth Environ. Sci.* **498** 012101

View the [article online](#) for updates and enhancements.



ECS **240th ECS Meeting**
Digital Meeting, Oct 10-14, 2021

**Register early and save
up to 20% on registration costs**

Early registration deadline Sep 13

REGISTER NOW

Potential Review on Energy Analysis Attributes for in 6 Dimension Application in Building Information Modelling (BIM)

Abdul Hadi Ahamad¹, Eeydzah Aminudin^{1*}, Rozana Zakaria¹, Nurulhuda Ahamad¹, A Rahim¹, L P Chung¹ and Santi Edra Nisa Lau¹

¹ School of Civil Engineering, Universiti Teknologi Malaysia, Skudai Johor, Malaysia

*Corresponding author: eeydzah@utm.my

Abstract. Rapid advancement on digitalisation is changing the way buildings are planned, designed, built and managed nowadays. A collaborative computer-based environment known as Building Information Modelling (BIM) is one of the advancements introduced as a platform to boost up the efficiency of the construction industry. However, poorly designed, constructed and managed building or infrastructure contribute to environmental issues such as CO² emissions and energy consumption. Thus, attachment of sustainability element in BIM not only increase the efficiency of the project but also can help to plan, design and construct in a more environmentally friendly way. A study on the overall energy use throughout the construction life cycle is needed to identify the most critical stages and to develop energy-reduction strategies via BIM. Thus, this paper provides an intensive review of BIM understanding, its energy analysis practices in the construction phase and existing building environmental assessment tools in BIM. To achieve this, an in-depth review was carried out focusing on the content analysis of a few journal articles related to BIM, energy analysis and sustainability assessment tool. Hence, this paper contributes by discussing the wide variety of building environmental assessment instruments and categorising existing tools to be used in the BIM.

1. Introduction

Resource scarcity, sustainability issues and stricter directives for reuse and resource efficiency in buildings [1] are empowering the Architecture, Engineering Construction (AEC), Facility Management (FM) and Deconstruction Communities to handle resources efficiently [2]. Because of growing environmental issues such as rising CO² emissions and energy dependence on fossil fuels, the construction sectors have been pushed to implement green building strategies [3–5]. Maintenance and deconstruction management are also significant levers for dealing with resource efficiency and enabling closed-loop material cycles due to long building life cycles. This can be seen in particular in developed countries with low new construction rates, construction activities gradually turning to modifications of buildings, retrofits and deconstruction of existing buildings.

Building Information Modelling (BIM) is a collaborative tool used in software applications in the AEC industries. [6]. It is a technology and a method to handle building projects [7]. Furthermore, BIM is a set of technological developments and processes that transform the design, analysis, construction and management of infrastructure [8]. On top of that, BIM will enhance and develop project schedules, design and development.

It is when sustainability begins in the post-construction phase, which falls under 6 Dimension (6D) BIM. Comprehensive environmental assessment, sustainable component monitoring, green rating



tracking, energy audit and other sustainability activities are involved within this stage. This study will, therefore, focus on the 6D BIM category, where processes and tools for sustainable development are discussed (Table 1).

Table 1. BIM classification in construction.

4D	5D	6D	7D
SCHEDULING	ESTIMATING	SUSTAINABILITY	FACILITY MANAGEMENT APPLICATIONS
<ul style="list-style-type: none"> ▪ Project Phasing Simulations ▪ Lean Scheduling ▪ Visual Validation for Payment Approval 	<ul style="list-style-type: none"> ▪ Real-time conceptual modelling and cost planning ▪ Quantity extraction to support detailed cost estimates ▪ Trade Verifications from Fabrication Models ▪ Value Engineering ▪ Prefabrication Solutions 	<ul style="list-style-type: none"> ▪ Theoretical energy analysis ▪ Detailed energy analysis ▪ Sustainable element tracking ▪ LEED tracking 	<ul style="list-style-type: none"> ▪ Life cycle BIM strategies ▪ BIM as-builts ▪ BIM embedded O&M manuals ▪ Data population and extraction ▪ BIM maintenance plans and technical support

2. Methodology

In this review paper, most data primarily obtained its resources from relevant web search in online academic publication databases for collecting academic and applied established journal articles (e.g. Automation in Construction, Journal of Cleaner Production, Journal Build Environment, Journal of Computer Science and Information Technology, Building and Environment, Energy and Buildings, etc.), conference papers, books, and others related to this topic. The contents assessed were enclosed to the main subject of assessment tools; (1) the previous studies of evaluation tools used for building; (2) life-cycle phases of construction projects; and (3) energy audit process and practice in evaluating energy performance that need to be improved to ensure energy usage to be reduced and keep in minimum use. Therefore, to refine data in the search engine, the keywords used to search related data in online academic publication for this paper essentially optimise “energy audit”, “energy analysis”, “6D BIM construction”, “assessment tools”, and “evaluation tools”. Every publication is analysed critically and compared with the other assessment tools for energy analysis to be applied in the construction phase. The outcome was eventually presented in this paper summarising the of energy analysis tools, previous studies, and the phases of life-cycle in which BIM which can be related to energy analysis towards the construction industry practices.

3. Energy audit

An energy audit can be characterised as a tool for evaluating the types and costs of energy consumption in buildings, assessing where a building uses energy, and finding opportunities to reduce its use. The Energy Conservation Act 2001 specifies the verification, tracking and analysis of energy use including the submission of a technical report including, the recommendation for energy efficiency enhancement with cost-benefit analysis and an action plan for reducing energy use [9]. It is a systematic method for determining and tracking the use of energy in the building and for defining the waste origin. The energy audit will estimate the total energy usage and, if necessary, the energy consumption of different equipment can also be calculated [10]. Potential energy conservation measures can be stimulated to improve the use of energy in a particular building. An energy audit can even predict the potential savings in energy and cost savings from efficient energy use [11]. The energy audit process is shown in Figure 1.

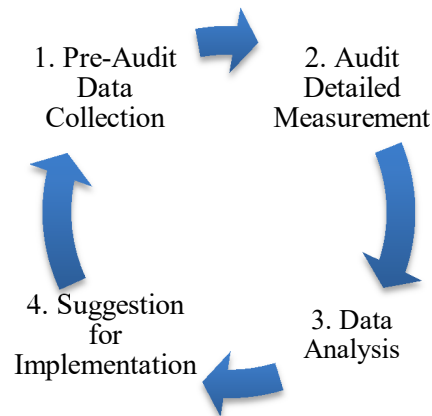

Figure 1. Energy audit process

4. The need and objective of an energy audit

An energy audit will help to understand more about how energy and fuel are used in any industry and help identify areas where waste can occur and where the scope is needed to improve resource efficiency. To understand which type of fuel or energy being used for the production and utilities of a particular process and product, the quantity and cost of different forms of energy will be identified. An energy audit provides preventive maintenance and will assist in continuing focusing on energy cost variations, monitoring energy consumption at different levels, availability, reliable energy supply, highlighting waste concerning inputs and outputs, identifying energy conservation technologies, retrofitting for energy conservation equipment, etc. [12].

Propose effective policies to reduce energy consumption by production unit or to reduce operational costs is the primary goal of an energy audit. An energy review provides a reference point for energy management in the organisation thus provides the basis for implementing more efficient energy use in the entire organisation [12], among of the energy audit goals listed as follows:

Collect and analyse historical energy consumption, a study of the building and its functional features, spot potential changes to reduce energy consumption and cost, conduct an engineering and economic assessment of possible changes, prepare a ranking list of appropriate adjustments, and report the analytical process and findings by writing a report.

5. Existing building environmental assessment tools

Environmental evaluation tools vary widely. There are various tools available for building components, entire buildings and entire building assessment frameworks. The tools cover multiple phases of the life cycle of a building and take account of various environmental problems. These instruments are global, national and, in some cases, local. Some national tools can be used as global tools if regional databases are updated [13]. Tools designed for various purposes such as research, consulting, decision-making and maintenance were developed. These issues lead to various users, such as designers, architects, scholars, contractors, owners, consultants and authorities. Variety of tools are used to evaluate existing and new buildings. Besides, the type of building (residential, office, and commercial) affects the choice of environmental assessment tool [14].

16 different building environmental assessment tools have been studied. They were chosen to know and well reflect existing tools of environmental assessment. The following methods were part of the study (Table 2), and it is literature-based only whereby none of the tools in this study has been tested.

Table 2. Building environmental assessment tools for this study.

Tool	Usage
ATHENA TM Environmental Impact Estimator	LCA-based software package that helps designers easily incorporate environmental information while in the early stages of a project
Building Environmental Assessment Tool (BEAT) 2002	LCA based tool developed for use during design of new buildings, where it can be used both early and later in the design phase, also been successfully used for retrofitting
BeCost	Resource for determining the life cycle of building structures and the building as a whole.
Building for Environment and Economic Sustainability (BEES) 4.0	Powerful software for selecting cost-effective, environmentally-preferable building products. Measure the environmental performance of building products by using the life-cycle assessment approach specified in the ISO 14040 series of standard
BREEAM	It recognises and reflects the value in higher performing assets across the built environment lifecycle, from new construction to in-use and refurbishment.
EcoEffect	To measure and evaluate the environmental effects of using a property in the long-term.
Eco-Profile	Help to determine the effect of greenhouse gas emissions and non-renewable energy use on many metrics.
Eco-Quantum	To assess the overall environmental impacts caused by a product or service
Tool	Usage
Invest 2	A tool that simplifies the otherwise very complex process of designing buildings with low environmental impact and whole life costs.
Environmental Status Model	Computerise the model and make it easy to use and compare buildings with each other for different purposes.
EQUER	A simulation tool developed in order to evaluate the life cycle and environmental quality of a building
ESCALE	Capable of assessing a building's environmental quality along with its development processes.
LEGEP	Tool for integrated life-cycle analysis. Supports design, development, quantity assessment, and analysis of new or existing structures by the planning departments.
Leadership in Energy and Design (LEED®)	Voluntary and regional quality based on consensus. It's an easy, algorithm-free rating system.
Programmation et Analyse de Projets d'Ouvrages	Decision-aid tool, aimed at owners of buildings, addresses a dozen environmental issues, with a particular focus on energy and users, and includes cost aspects.
TEAM TM	Enables any industrial system to be described and its associated cycle inventories, and potential environmental impacts to be calculated.

6. Building environmental assessment tools

There are several tools with many specific functions in BIM, including environmental assessment tools, which are used to predict or evaluate the total energy performance in various phases of the building life

cycle. Previously, environmental assessment methods were more evaluated as individuals than as groups. Such methods, however, be separated into two (2) well-known classification systems in this review. One was established by the Institute of ATHENA and the other by IEA Annex 31 [15].

The focus in the ATHENA classification is on evaluation tools. The tools are divided into different levels depending on where they are used during the assessment process and for what purpose [15]. In addition to the evaluation tools, the IEA Annex 31 includes software for energy modelling, various environmental policies, checklists, product declarations and classification system authorisations. Therefore, in the IEA Annex 31 category, the area of classified methods is much broader than in the ATHENA classifications. All tools classified in the ATHENA category belong in the IEA Annex 31 classification to the second or third tier.

6.1. ATHENA classification system

The ATHENA Institute introduced an ' Assessment Tool Typology ' classification system (referred to later as ATHENA classification) [15] which consists of three levels (Table 3):

Table 3. ATHENA classification level.

Rank	Description	Tools
Level 1	Tools for comparing products and sources of information	BEES 3.0 and TEAM™
Level 2	Whole building design or decision support tools	ANTHENA™, BEAT, BeCost, Eco-Quantum, Envest 2, EQUER, LEGEP, and PAPOOSE
Level 3	Framework or systems for building evaluation	BREAM, EcoEffect, EcoProfile, Environmental Status Model, ESCALE, and LEED.

6.2. IEA Annex 31 classification system

The assessment tools were classified into five categories in the IEA Annex 31 project "energy-related environmental impacts of buildings" [15]. The classification system here merged with the classification system of ATHENA (Figure 2):

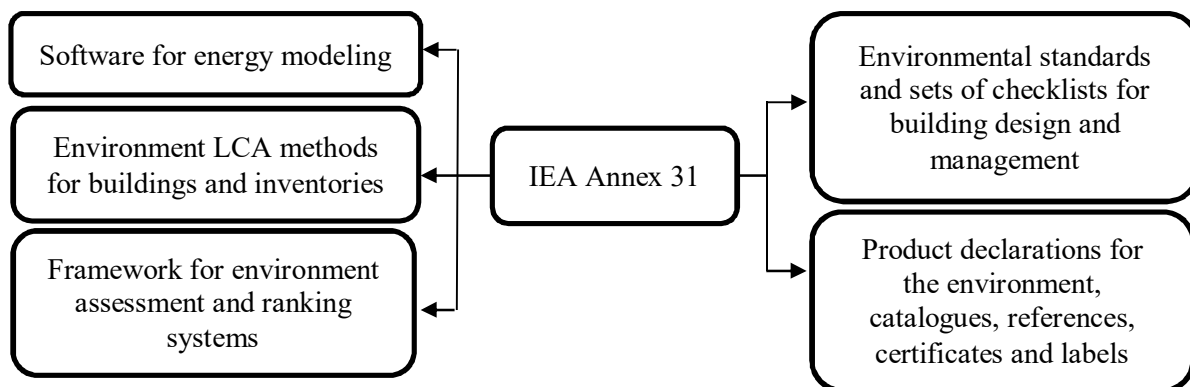

Figure 2. Annex 31 classification system.

6.3. Assessed building

Environmental assessment tools can be used to evaluate existing buildings, new buildings, renovated buildings, as well as buildings products and components (Table 4). Level 1 tools are mainly for comparison of product and information resources. Meanwhile, Levels 2 and 3 category tools are mostly used to assess the environment in an entire building [15].

A few of the tools are suitable for comparing products and evaluating the environment for building holistically, BEAT and EcoEffect, as well as TEAMTM at certain levels. The whole building is divided into parts and elements when TEAMTM is used for an evaluation of an entire building. Nevertheless, Level 1 tools can be overloaded if used in decision-making for a whole building [15]. Although TEAMTM can be used to analyse the entire building, it was not initially designed for this task. TEAMTM is, therefore considered a tool for comparing items.

There are different building categories; residential buildings (single-family or multi-units), office buildings and other building forms. The majority of the methods included in this study can be used for the assessment of several building types. Nevertheless, some of the instruments can be used in specific building types only; for example, Envest 2 may be used for the environmental assessment of office buildings only. Some of the references used do not distinguish different building categories. In such instances, it is impossible to know whether or not the assessment method is suitable for all types of buildings.

Table 4. Tools for assessment in life cycle phases.

Level	Assessment tool	Construction	Use/operation	Maintenance	Demolition
1	BEES 4.0		●	●	
	TEAM TM	●	●	●	
2	ANTHENA TM	●		●	●
	BEAT 2002	●	●	●	●
	BeCost				
	Eco-Quantum	●	●	●	●
	Envest 2	●	●	●	●
	EQUER	●	●	●	●
	LEGEP	●	●	●	●
Level	Assessment tool	Construction	Use/operation	Maintenance	Demolition
3	PAPOOSE		●	●	●
	BREEAME	●	●	●	
	EcoEffect	●	●	●	●
	EcoProfile		●	●	
	Environmental Status Model				
	ESCALE	●	●	●	●
	LEED	●	●	●	●

6.4. Life cycle phases

To compare building environmental assessment tools, the lifecycle of a building "from the cradle to the grave" is divided into stages. The tools address the life cycle stages of the building accordingly. Half of the tools cover all life cycle stages; four Level 2 tools, and two Level 3 tools. Certain of the tools do not include in one or two of life cycle stages. TEAMTM and BREEAM do not cover demolition but do cover disposal.

Furthermore, among construction phases, ATHENATM excludes covering operation phase. Though, a tool like TEAMTM can develop LCA demolition process model. Among the tools which are EcoProfile and ESCALE, emphasis further towards building usage and care. Some tool can use multiple criteria for a process, whereas another tool only uses a few requirements, although both tools cover the phase. Also, corresponding to different indicators, tools might use the same parameters to suit these criteria.

7. Sustainable building assessment tool typology

Energy analysis is beneficial for energy auditor to evaluate a building construction [16]. While there are lots of assessment tools with varieties of functions that suitable to be applied in construction phases, [16] stated that these tools mostly be classified in level 2 of ATHENA classification system due to its function as a decision support tools for energy assessor or auditor. The integration of an energy audit in 6D BIM phase will reinforce sustainability in the life cycle phase of building construction [16]. Being a decision support tools means it will assist energy auditor in conducting energy evaluation more precise with the additional support of model simulation, and comprehensive data extraction [16]. Figure 3 illustrated a typology for a building assessment tool typology where it highlights the key flow of energy evaluation process in sustainable construction practice.

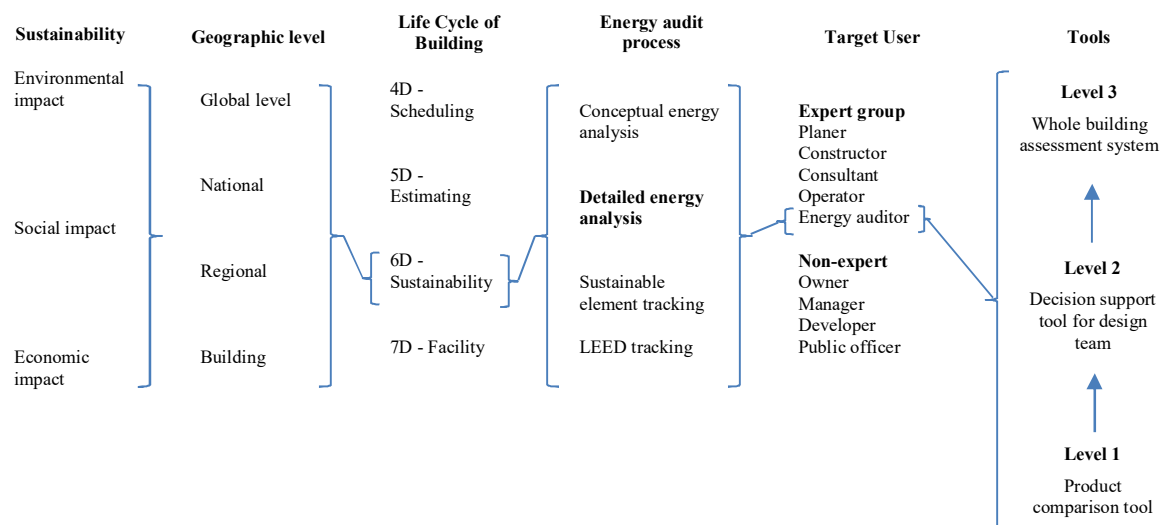

Figure 3. A typology for a sustainable building assessment tool.

8. Conclusions

BIM implementation can lead to successful project development in construction projects. In the construction industry, BIM tools have been used to improve the building process and analyse the building energy consumption, respectively. By enhancing the project schedule, detecting conflicts during the design phase, reducing the costs of building and improve communication between construction players, BIM will benefit building projects. Since the area of environmental assessment building tools is broad, this study aims to explain this field by evaluating and categorising the resources that exist. Comparisons between the instruments and the outcomes are not easy. The tools for assessing different types of building, for instance, emphasise different phases of the life cycle and use various databases, guidelines and questionnaires.

Assessment methods are solutions for the implementation and calculation of evaluation methods. The tools can often be used to aid scheduling and decision-making in the design phase. The 13 instruments used in this study are assessment tools, which can be used as planning tools (level 1 and 2 tools, and also Level 3 Tools which is EcoProfile and ESCALE). Software programs are the majority of environmental assessment tools. Nevertheless, perimeter range is massive. The more assessment and data involved, the more reliant such tools for intellect construction technology.

9. References

[1] Regulation E U 2011 Regulation (EU) No. 305/2011 of the European Parliament and of the Council of 9 March 2011 laying down harmonized conditions for the marketing of construction products and repealing Council Directive 89/106/EEC *Official J. of the European Union L* **88** 5-43

- [2] Akbarnezhad A, Ong K C G and Chandra L R 2014 Economic and environmental assessment of deconstruction strategies using building information modelling *Automation in Construction* **37** 131-144
- [3] Eastman C, Teicholz P, Sacks R and Liston K 2011 *BIM handbook: A guide to building information modelling for owners, managers, designers, engineers and contractors* (New Jersey: John Wiley & Sons)
- [4] Lu Y and Song X 2017 Beyond boundaries: global use of life cycle inventories for construction materials *J. of Cleaner Production* **156** 876-887
- [5] Chang R D, Soebarto V, Zhao Z Y and Zillante G 2016 Facilitating the transition to sustainable construction: China's policies *J. of Cleaner Production* **131**(2) 534-544
- [6] Robinson C 2007 Structural BIM: discussion, case studies and latest developments *The structural design of tall and special buildings* **16**(4) 519-533
- [7] Azhar S, Behringer A, Sattineni A and Mqsood T 2012 BIM for facilitating construction safety planning and management at job sites *Proceedings of the CIB-W099 International Conference: Modelling and Building Safety (Singapore)* pp. 10-11
- [8] Cho H, Lee K H, Lee S H, Lee T, Cho H J, Kim S H and Nam S H 2011 Introduction of Construction management integrated system using BIM in the Honam High-speed railway lot No. 4-2 *Proceedings of the 28th ISARC (Seoul, Korea)*
- [9] Kulkarni S U and Patil K 2013 Energy audit of an industrial unit-A Case Study *Int. J. of Emerging Science and Engineering (IJESE) ISSN 2319-6378*
- [10] Yik F W, Yee K F, Sat P S and Chan C W 1998 A detailed energy audit for a commercial office building in Hong Kong *HKIE Transactions* **5**(3) 84-88
- [11] Saidur R, Rahim N A, Masjuki H H, Mekhilef S, Ping H W and Jamaluddin M F 2009 End-use energy analysis in the Malaysian industrial sector *Energy* **34**(2) 153-158
- [12] Dongellini M, Marinosci C and Morini G L 2014 Energy audit of an industrial site: a case study *Energy Procedia* **45** 424-433
- [13] Singh M, Singh G and Singh H 2012 Energy audit: a case study to reduce lighting cost *Asian J. of Computer Sci. and Information Technology* **2**(5) 119-122
- [14] Haapio A and Viitaniemi P 2008 A critical review of building environmental assessment tools, *Environmental impact assessment review* **28**(7) 469-482
- [15] Hobday R 2010 *Energy-related environmental impact of buildings* Tech. Synth. Rep Annex 31 (United Kingdom:FaberMaunsell Ltd.)
- [16] Trusty W B 2000 Introducing an assessment tool classification system *Advanced Building Newsletter* **25**(7) 125-134

Acknowledgements

The authors would like to thank Universiti Teknologi Malaysia for supporting with financial grants, Cost Centre No: Q.J130000.2522.19H53, Q.J130000.3551.06G64, GreenPROMPT research team members and Department of Construction Management, UTM CRC, together with the opportunity to conduct the research.