

Control Strategies and Novel Techniques for Autonomous Rotorcraft Unmanned Aerial Vehicles: A Review

SHERIF I. ABDELMAKSOU¹, MUSA MAILAH¹, (Senior Member, IEEE),
AND AYMAN M. ABDALLAH²

¹School of Mechanical Engineering, Universiti Teknologi Malaysia (UTM), Johor Bauru 81310, Malaysia

²Department of Aerospace Engineering, King Fahd University of Petroleum and Minerals, Dhahran 31261, Saudi Arabia

Corresponding author: Sherif I. Abdelmaksoud (iasherif@graduate.utm.my)

ABSTRACT This paper presents a review of the various control strategies that have been conducted to address and resolve several challenges for a particular category of unmanned aerial vehicles (UAVs), the emphasis of which is on the rotorcraft or rotary-wing systems. Initially, a brief overview of the important relevant definitions, configurations, components, advantages/disadvantages, and applications of the UAVs is first introduced in general, encompassing a wide spectrum of the flying machines. Subsequently, the focus is more on the two most common and versatile rotorcraft UAVs, namely, the twin-rotor and quadrotor systems. Starting with a brief background on the dual-rotor helicopter and a quadcopter, the full detailed mathematical dynamic model of each system is derived based on the *Euler–Lagrange* and *Newton-Euler* methods, considering a number of assumptions and considerations. Then, a state-of-the-art review of the diverse control strategies for controlling the rotorcraft systems with conceivable solutions when the systems are subjected to the different impediments is demonstrated. To counter some of these limitations and adverse operating/loading conditions in the UAVs, several innovative control techniques are particularly highlighted, and their performance are duly analyzed, discussed, and compared. The applied control techniques are deemed to produce a useful contribution to their successful implementation in the wake of varied constraints and demanding environments that result in a degree of robustness and efficacy. Some of the off-the-shelf developments in the rotorcraft systems for research and commercial applications are also presented.

INDEX TERMS Rotary-wing system, rotorcraft, unmanned aerial vehicle, twin-rotor helicopter, quadcopter, hexacopter, linear/non-linear controllers, robust/adaptive control, artificial intelligence, disturbance rejection, slung or swing load motion, chattering effect, nontrivial maneuvers, collision avoidance, fault-tolerant control, autonomous system, shared autonomy, teleoperation, machine learning.

I. INTRODUCTION

There is no doubt that the field of unmanned aerial vehicles (UAVs) is one of the pivotal areas of research that has attracted researchers from various academic and industry disciplines. Not surprisingly, the high concentration of UAVs applications is due to the rapidly growing technological prosperity and several desirable features such as light weight, high maneuverability, low cost, and fuel efficiency. This leads to utilizing them in a wide range of applications such as surveillance, aerial photography and video, mapping

The associate editor coordinating the review of this manuscript and approving it for publication was Huiping Li.

and traffic monitoring, search and rescue, meteorological reconnaissance, civil and military tasks [1].

Before we begin to move forward on the UAVs, let us first briefly discuss the different types of systems. Based on robotics, the systems may be divided into three categories: autonomous, shared autonomous, and teleoperation systems. An autonomous system is a system with some level of automation to assist or replace human control. Based on the Society of Automotive Engineers (SAE), automated functionality ranges from no automated features (level 0) to full automation (level 5) [2]. While the shared autonomous system is the integration of human interaction using a feedback loop with system autonomy to generate a bilateral shared

control system. It is a user-system interaction to achieve shared goals [3], [4]. Meanwhile, teleoperation is the full operation of the system by the user but performed remotely [5].

Regarding unmanned aerial systems (UASs), a block diagram architecture of the different systems is demonstrated in **Figure 1**. While the different types of autonomous and shared autonomous systems with their advantages and disadvantages as well as real-time applications are shown in **Table 1**.

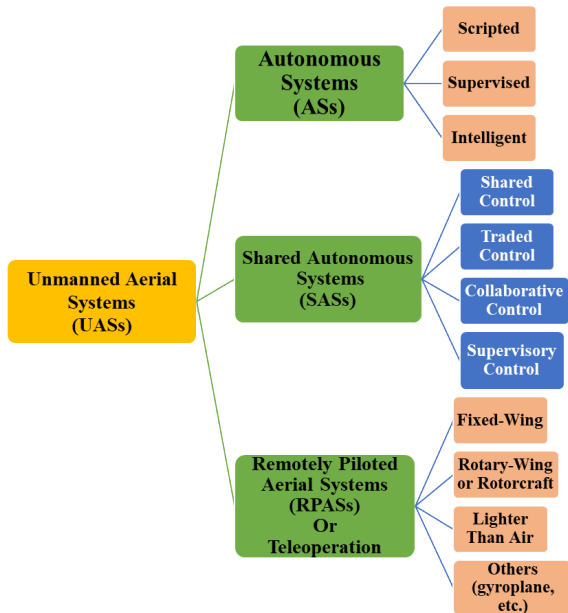

FIGURE 1. The different unmanned aerial systems [3], [4], [7], [8].

The term UAV is utilized to depict any vehicle that has no one on its board amid its flight. UAVs can be categorized by five parameters, namely, size, mission, capability, degree of autonomy, and aero-structural configuration [6] described as follows:

Size: The size where the maximum take-off weight (MTOW) is the factor that distinguishes between aerial vehicles:

- <2 kg – micro
- 2-20 kg – small
- 20-150 kg – medium
- >150 kg - large

Mission: It includes six fundamental points; surveillance, combat, transportation, support, communications, and target.

Capability: It relates to performance, such as range, endurance, speed, payload, and service ceiling.

Degree of autonomy: It relates to guidance, planning, and self-accomplishment of the assigned tasks.

Aero-structural configuration: It concentrates on design, configuration, and the interconnection between the fields of structure and aerodynamics.

Each type of UAV is equipped with some basic components such as, the body (structure) that connects the entire system with each other, and the propulsion system or power supply

TABLE 1. Types of autonomous and shared autonomous systems with their advantages, disadvantages, and real-time applications [3], [4], [7], [8].

	Autonomous Systems	Shared Autonomous Systems
Types	<p>Scripted</p> <ul style="list-style-type: none"> Systems that are basically autopilots Perform preplanned scripts of actions based on foreseen events to accomplish the mission objective <p>Supervised</p> <ul style="list-style-type: none"> Allow the evolution of mission sequence <p>Intelligent</p> <ul style="list-style-type: none"> Allow the evolution of mission objective Aims to implement the human directives Adapt to unforeseen events 	<p>Shared/Guided Control</p> <ul style="list-style-type: none"> Focus on the control generating from the user towards the system which has its own control loop and is autonomously reacting to the environment and executes the specified action. <p>Traded Control</p> <ul style="list-style-type: none"> The user and system take turns. <p>Collaborative Control / Mixed-Initiative Control</p> <ul style="list-style-type: none"> The user and system share a task and work as a group collaboratively in the same space and at the same time <p>Supervisory Control</p> <ul style="list-style-type: none"> The user only monitors the execution of the autonomously working system.
Advantages	<ul style="list-style-type: none"> Time-saving Much safer Extra navigation systems and maps 	<ul style="list-style-type: none"> Exploit the benefits of human control and machine control. Safe navigation, control, and stable interaction. Extend human operators sensing and manipulation capability.
Disadvantages	<ul style="list-style-type: none"> High cost for implementing the technology Complex communication networks Hacking and security aspects Lacks adaptation in difficult and complex tasks 	<ul style="list-style-type: none"> Safety concerns Policy and operational framework Large time delay Limited bandwidth and insufficient visibility of visual feedback signal-based design
Real-time applications	<ul style="list-style-type: none"> UAVs Flying in hazardous or radiation areas 	<ul style="list-style-type: none"> Search and rescue mission Monitoring and inspection tasks

that propels or lifts the entire structure in a certain direction and resists the drag force. Also, sets of sensors that monitor specific parameters and groups of actuators that drive certain subsystems in the desired positions. Finally, a combination of the data processing unit, flight controller, or communication

systems, which is responsible for planning, navigation, and guidance [9].

Due to the many features of UAVs such as ease of maintenance compared to manned vehicles, small size, high-mobility, self-stability, and automatic navigation, they gained great global attractions over the past three decades. They have been used in a wide range of applications, for instance, search and rescue, image processing and analysis, remote sensing, precision agriculture, real-time monitoring of road traffic, security and surveillance, freight transport, civil infrastructure inspection [10], measuring hazardous gases [11], providing wireless coverage [1], [10], monitoring of forest resources and real-time forest fire [12], and thermal detection of the human body using a built-in thermal camera in the case of spreading of some viruses such as COVID-19.

Based on the classification of aerodynamic configuration, UAVs are usually classified into three categories as shown in Figure 2 [13]:

- (1) fixed-wing aircraft, with the advantages of long-endurance, long-range, and high cruise speed.
- (2) rotary-wing or rotorcraft such as the helicopter, quadcopter, hexacopter, octocopter, etc.
- (3) flapping-wing aircraft, which fly like birds and insects [14].

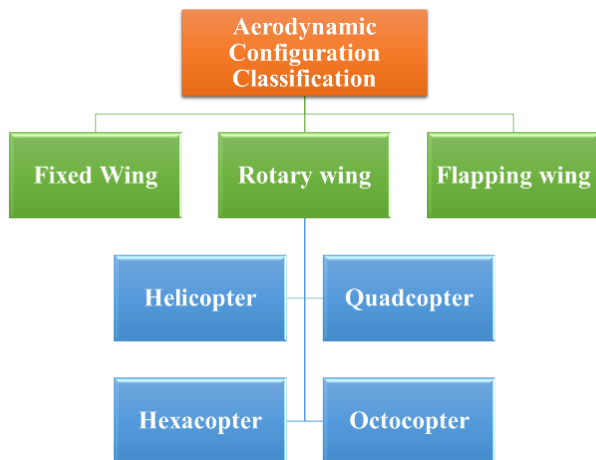

FIGURE 2. UAVs classification based on aerodynamic configuration [13].

Each classification has its design specifications, advantages, and shortcomings [15], as shown in Figure 3. Another promising trend is the hybrid UAVs, which can combine the advantages of both fixed-wing and VTOL systems such as in the work done by [1], [16]. In this work, the focus is more on the rotorcraft systems due to their numerous features and applications.

Rotorcraft or rotary-wing systems, among other types of UAVs, are distinguished by their ability to take-off and land vertically, hover in one spot or limited zones, perform swift maneuvers, and fly backward or sideways. The different types of fixed and multirotor with their advantages and disadvantages as well as real-time applications are shown in Table 2.

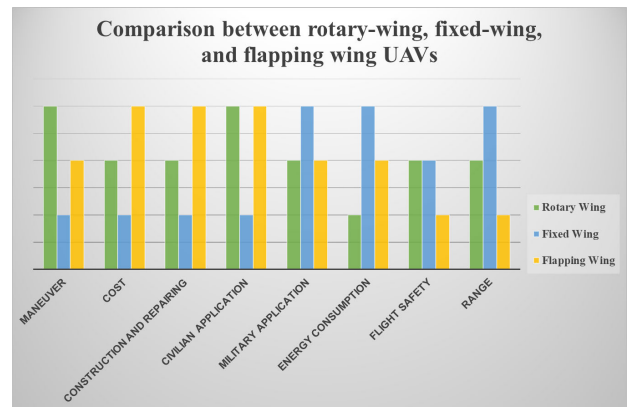

FIGURE 3. Comparison between rotary-wing, fixed-wing, and flapping wing UAVs.

TABLE 2. Types of fixed and multirotor systems with their advantages, disadvantages, and real-time applications [1], [17], [18].

	Fixed	Multirotor
Types	Straight Wing: <ul style="list-style-type: none"> Rectangular Straight Wing Tapered Wing Rounded or elliptical wing 	Helicopter UAV with dual rotors Quadcopter UAV with four rotors Hexacopter UAV with six rotors Octocopter UAV with eight rotors Decacopter UAV with twelve rotors
Advantages	Swept Wing: <ul style="list-style-type: none"> Slightly swept wing Moderately swept wing Highly swept wing <ul style="list-style-type: none"> Higher flight safety More energy-efficient Longer range and endurance Excellent stability 	<ul style="list-style-type: none"> Ability to take-off and land vertically Landing/take-off substantial area is not required Ability to hover in one spot Ability to perform agile maneuvering
Disadvantages	<ul style="list-style-type: none"> Lacks hovering capability Need more space for take-off and landing 	<ul style="list-style-type: none"> Lower speeds and shorter flight ranges Small payload capacity
Real-time applications	<ul style="list-style-type: none"> Surveillance Aerial mapping Military tasks 	<ul style="list-style-type: none"> Aerial photography and video recording Aerial inspection

There are various types of rotorcraft systems, such as the helicopter, quadcopter, hexacopter, octocopter, decacopter, etc. Among these models, helicopter and quadcopter can be considered the most widespread flying machines nowadays and have attracted many researchers over the past few years due to their many benefits and uses. However, for heavy payloads and shorter flight durations, hexacopter and octocopter

are the best options however are relatively expensive and heavy with higher energy consumption [13]. Thus, this paper concentrates on the twin-rotor helicopter and quadcopter and the derivation of their mathematical models, as case studies while various control strategies for all rotorcraft UAVs were discussed.

The helicopter is a multi-variable, nonlinear, and strongly coupled system. A two degree's of freedom (2-DOF's) helicopter model is a dual-rotor laboratory experimental rig that is commonly used as a test platform, to verify the effectiveness of control strategies designed for a real helicopter system. It consists of two propellers at both ends of a beam pivoted on its fixed base allowing to rotate freely in both the vertical and horizontal planes. The front rotor, which is horizontal to the ground, is the main rotor and causes a pitching moment around the pitch axis while the back or tail rotor generates a yawing moment around the yaw axis. Both the front and back rotors generate a torque on each other resulting in the coupling effect. The beam is driven by two perpendicular propellers that are actuated by two DC motors. A number of researches have been conducted to develop control techniques for the twin-rotor helicopter over the past decades to provide appropriate robust solutions in demanding environments.

On the other hand, the quadcopter is a multirotor UAV that is lifted by four rotors and consists of a rigid body connected by four propellers with fixed-pitch blades as their airflows point downward to generate a lifting upward force. The propellers' axes of rotation are fixed and parallel to each other. Also, the quadcopter has two pairs of identical propellers, two rotate clockwise (CW) while the other two counter-clockwise (CCW), allowing the quadcopter to be controlled by varying the speed of rotors. The arrangements of rotors with respect to the quadcopter body coordinate system usually lead to three quadcopter configurations: the 'X', '+', and 'H' types. Each configuration has its advantages as the first type is the most stable design among them while the second configuration is more used for acrobatic flight and the last one is utilized for races [15], [19].

The quadcopter has six DOFs, namely, x , y , and z which are translational motions, and ϕ , θ , and ψ which are rotational motions, and only four propellers (inputs); throttle, roll, pitch, and yaw motions. If one of the pairs rotates CW and the other CCW (equal in magnitude), then this is considered having a yaw motion tendency causing the quadcopter to bend either right or left around the vertical axis. For the upward and downward movements (+Throttle and -Throttle), all four rotors should be accelerated up or down at the same speed. To move forward/backward (pitching) or right/left (rolling), a difference in the angular velocities must occur between the pairs, as shown in **Figure 4** [13]. Therefore, the quadcopter model is an underactuated mechanical system with two degrees of underactuation.

Rotorcraft UAVs encounter several challenges during the flight-related to instability, moving and fixed obstacles, motors failure, trajectory tracking, external disturbances,

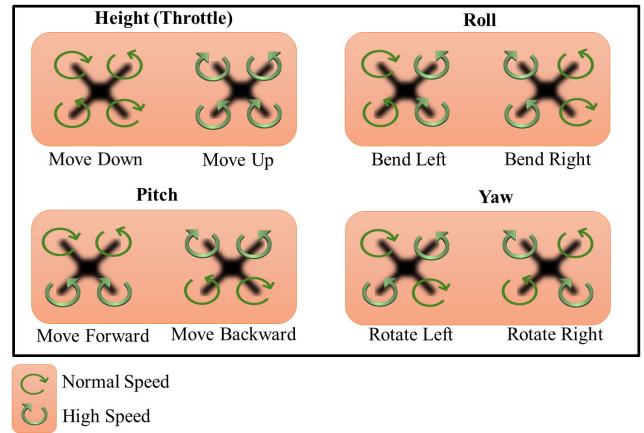

FIGURE 4. Quadcopter movements [13].

model uncertainties, etc. Before discussing the different control strategies that have been proposed to solve some of these impediments, it is deemed necessary to describe adequately the mathematical model as it plays a vital role in understanding the behavior of the dynamic system. In this study, the mathematical models for both the 2-DOF helicopter and quadcopter systems were fully derived in the following section as case studies.

The motivation for this work stems from the need to provide a state-of-the-art review of the current and diverse control systems that have been proposed for a specific and widespread class of the UAVs called rotorcraft or rotary-wing aircraft. Moreover, a comparative discussion of the differences between linear, non-linear, and intelligent control strategies in terms of the advantages and drawbacks of each system is presented to reach the most appropriate selection based on various difficulties faced by rotorcraft systems and other factors that may affect their performance in successfully completing their missions. Several novel and innovative techniques are also introduced to provide a successful operation in various loading and operating conditions with added robustness in challenging environments. Furthermore, several research problems that need more attention are highlighted. Lastly, some of the off-the-shelf developments in rotorcraft systems for research and commercial use are presented.

The rest of this paper is set as follows: Section 2 describes the dynamics of the 2-DOF helicopter and quadcopter under certain considerations. Then, a state-of-the-art review of various control strategies and innovative techniques are discussed in section 3. Section 4 shows some of the current developments in rotorcraft UAVs. Finally, the conclusion is presented in section 5.

II. MODELING THE SYSTEM DYNAMICS

The mathematical model has an essential role in describing the properties of the dynamic system. Thus, it is necessary to obtain an accurate dynamic model whose functional details are the inputs to the control system. In the following sections, the mathematical models of the 2-DOF helicopter and

quadcopter were derived, as case studies of the rotorcraft systems. The *Euler-Lagrange* formulation was utilized for the 2-DOF helicopter model, while the *Newton-Euler* method was used for the quadcopter system, considering various considerations and assumptions.

A. 2-DOF HELICOPTER MODELING

In this section, the mathematical model of the 2-DOF helicopter model is derived according to the work done in [20].

The 2-DOF helicopter model was derived based on the following assumptions [21], [22]:

- The main and back rotors are the same size and equidistant from each other
- Both the front and back rotors generate a torque on each other.
- The model is horizontal and parallel to the ground when the pitch angle is zero.
- The pitch angle increases positively when the front rotor is moved upwards, and the body rotates CCW about the y-axis and the front rotor voltage is positive.
- The yaw angle increases positively when the body rotates CCW about the z-axis and the back-rotor voltage is positive.
- As the system is fixed, it cannot rotate around the roll axis or move along the axis.

To derive the model of the 2-DOF helicopter, it is necessary to note that the center of mass displaces a distance l_{cm} on the x-axis, as shown in **Figure 5**. Thus, after undergoing a transformation of the coordinates based on the pitch and yaw rotation matrices, the center of mass, is as follows [20]:

$$\begin{aligned} X_{cm} &= l_{cm} \cos \psi \cos \theta \\ Y_{cm} &= l_{cm} \sin \psi \cos \theta \\ Z_{cm} &= l_{cm} \sin \theta \end{aligned} \tag{1}$$

where θ and ψ are the pitch and yaw angles, respectively, l_{cm} is the distance of the center of mass and intersection of the pitch and yaw axes. The center of mass is represented by the *Cartesian* coordinate with respect to the pitch and yaw angles.

Based on the free body diagram of the 2-DOF helicopter shown in **Figure 5**, the total potential energy (PE) of the system due to gravity is [20]:

$$PE = m_h g l_{cm} \sin \theta \tag{2}$$

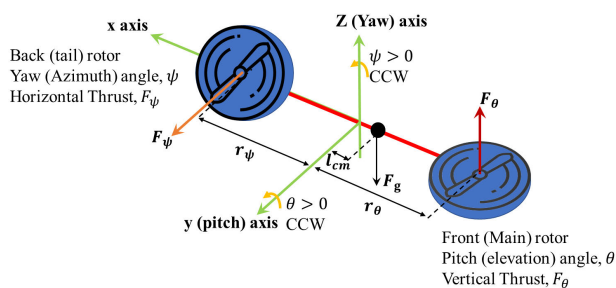

FIGURE 5. Free-body diagram of the 2-DOF helicopter model.

The total kinetic energy (KE) based on **Figure 5**, is the combination of the rotational KEs acting on the pitch and yaw motions, respectively. The translational KE generated by the movement of the center of mass is given by [20]:

$$\begin{aligned} KE &= \frac{1}{2} J_{\theta} \dot{\theta}^2 + \frac{1}{2} J_{\psi} \dot{\psi}^2 + \frac{1}{2} m_h [(-\sin(\psi) \dot{\psi} \cos(\theta) l_{cm} \\ &\quad - \cos(\psi) \sin(\theta) \dot{\theta} l_{cm})^2 + (-\cos(\psi) \dot{\psi} \cos(\theta) l_{cm} \\ &\quad + \sin(\psi) \sin(\theta) \dot{\theta} l_{cm})^2 + \cos(\theta)^2 \dot{\theta}^2 l_{cm}^2] \end{aligned} \tag{3}$$

where,

J_{θ}, J_{ψ} : total moment of inertia about the pitch and yaw axes, respectively

m_h : total moving mass

The torques generated at the pitch and yaw axes are a function of the voltages applied to the motors [23],

$$\begin{aligned} \tau_{\theta}(t) &= K_{\theta\theta} u_{\theta}(t) + K_{\theta\psi} u_{\psi}(t) \\ \tau_{\psi}(t) &= K_{\psi\theta} u_{\theta}(t) + K_{\psi\psi} u_{\psi}(t) \end{aligned} \tag{4}$$

where,

$\tau_{\theta}(t), \tau_{\psi}(t)$: control torques act on the pitch axis and yaw axes, respectively

$u_{\theta}(t), u_{\psi}(t)$: control actions applied as motor voltages to the pitch and yaw rotors, respectively

$K_{\theta\theta}$: torque thrust gain from the pitch rotor

$K_{\theta\psi}$: cross-torque thrust gain acting on the pitch from the yaw rotor

$K_{\psi\theta}$: cross-torque thrust gain acting on the yaw from the pitch rotor

$K_{\psi\psi}$: torque thrust gain from the yaw rotor

The generalized forces vector is given by [23]:

$$\begin{aligned} \mathbf{Q} = [Q_1, Q_2] &= [K_{\theta\theta} u_{\theta}(t) + K_{\theta\psi} u_{\psi}(t) - D_{\theta} \dot{\theta}(t), \\ &\quad K_{\psi\theta} u_{\theta}(t) + K_{\psi\psi} u_{\psi}(t) - D_{\psi} \dot{\psi}(t)] \end{aligned} \tag{5}$$

where D_{θ} and D_{ψ} are the damping about the pitch and yaw axes, respectively.

From the *Lagrangian* of the system, the non-conservative forces of the system are written as [23]:

$$\begin{aligned} \frac{\partial}{\partial t} \frac{\partial L}{\partial \dot{q}_1} - \frac{\partial}{\partial q_1} L &= Q_1 \\ \frac{\partial}{\partial t} \frac{\partial L}{\partial \dot{q}_2} - \frac{\partial}{\partial q_2} L &= Q_2 \end{aligned} \tag{6}$$

where,

q_1 and q_2 : generalized coordinates θ and ψ , respectively

L : *Lagrangian* equation which is the difference between the total kinetic and potential energies of the system, $L = KE - PE$

Based on the *Euler-Lagrange* formulation, the nonlinear dynamic equations of motion that describe the motions of the pitch and yaw with the servo motor voltages can be described as follows [24]:

$$(J_\theta + m_h l_{cm}^2) \ddot{\theta} + D_\theta \dot{\theta} + \alpha + \beta = K_{\theta\theta} u_\theta + K_{\theta\psi} u_\psi \quad (7)$$

where,

$$\alpha = m_h l_{cm}^2 \dot{\psi}^2 \sin(\theta) \cos(\theta)$$

$$\beta = m_h g l_{cm} \cos(\theta)$$

$$(J_\psi + m_h l_{cm}^2 \cos(\theta)^2) \ddot{\psi} + D_\psi \dot{\psi} - \gamma = K_{\psi\theta} u_\theta + K_{\psi\psi} u_\psi \quad (8)$$

where,

$$\gamma = 2m_h l_{cm}^2 \sin(\theta) \cos(\theta) \dot{\theta} \dot{\psi}$$

For the control design, and by linearizing the system around an operating point, the linearized model can be expressed as [25]:

$$(J_\theta + m_h l_{cm}^2) \ddot{\theta}(t) + D_\theta \dot{\theta}(t) = K_{\theta\theta} u_\theta + K_{\theta\psi} u_\psi \quad (9)$$

$$(J_\psi + m_h l_{cm}^2) \ddot{\psi}(t) + D_\psi \dot{\psi}(t) = K_{\psi\theta} u_\theta + K_{\psi\psi} u_\psi \quad (10)$$

The closed-loop schematic block diagram of a 2-DOF helicopter model is shown in **Figure 6**.

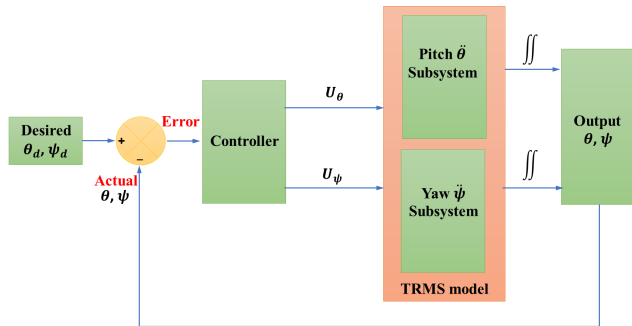

FIGURE 6. Schematic block diagram of a 2-DOF helicopter model.

B. QUADCOPTER MODELING

The quadcopter is a non-linear MIMO dynamic system that has a complex structure with high non-linear terms. Thus, obtaining the mathematical model is considered a difficult task [15], [26]–[28]. In this section, the detailed mathematical model of a quadcopter system was derived based on the work done in [29], [30].

1) COORDINATE FRAMES

To derive the dynamics of the quadcopter, the coordinate frames used to describe the motion must be initially defined. **Figure 7** shows the earth (inertial) fixed frame with $x_E - y_E - z_E$ axes and the body fixed frame with $x_B - y_B - z_B$ axes. The distance between the earth fixed frame and the

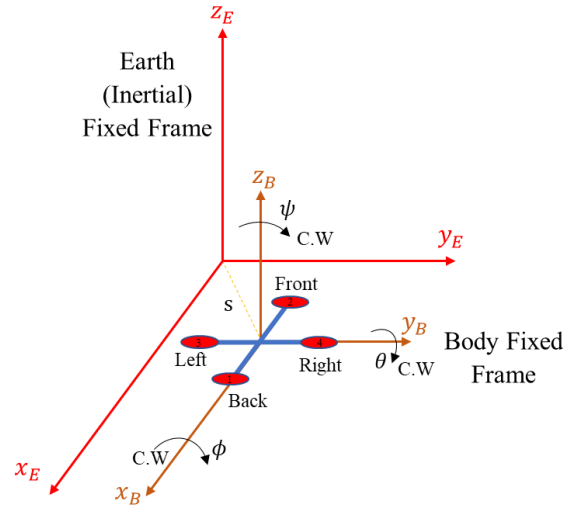

FIGURE 7. Earth (inertial) fixed frame and the body-fixed frame.

body-fixed frame is the absolute distance between the center of gravity of each other, s . Here, the *Euler* angles were utilized for describing the orientation of a model in space with respect to the earth coordinate frame by defining two intermediate coordinate systems: Frame 1 and Frame 2 beside the earth and body-fixed frames. Let R_E^B defines the rotation from the earth fixed frame to the body-fixed frame. Therefore, the rotation R_E^B is given by:

$$R_E^B = R_{f_2}^B R_{f_1}^{f_2} R_E^{f_1} \quad (11)$$

where the notation $R_E^{f_1}$ indicates a rotation from earth Frame E to Frame 1 which is the first intermediate frame, and $R_{f_1}^{f_2}$ indicates a rotation from Frame 1 to Frame 2 which is the second intermediate frame wherein, $R_{f_2}^B$ describes a transformation from Frame 2 to body Frame B . Therefore, the complete rotation matrix from the body-fixed frame to the earth fixed frame R is given by:

$$R = R_B^E = \begin{bmatrix} c\theta c\psi & s\phi s\theta c\psi - c\phi s\psi & c\phi s\theta c\psi + s\phi s\psi \\ c\theta s\psi & s\phi s\theta s\psi + c\phi c\psi & c\phi s\theta s\psi - s\phi c\psi \\ -s\theta & s\phi c\theta & c\phi c\theta \end{bmatrix} \quad (12)$$

Note that in equation (12) and other related equations that follow, $c = \cos$ and $s = \sin$.

A quadcopter can be considered as five inflexible bodies associated together in relative motion [26]. These five bodies are the quadcopter body itself B , and four propellers r_i attached to the rigid body as shown in **Figure 8**.

Let $F_{T_E} : \{O_E, x_E, y_E, z_E\}$ be the earth fixed frame attached to its center of gravity O_E whereas, $F_{T_B} : \{O_B, x_B, y_B, z_B\}$ be the body-fixed frame attached to its center of gravity O_B . Also, the rotors frames are taken to be parallel to each other and attached to their centers of gravity O_{r_i} . They are given by $F_{T_{r_i}} : \{O_{r_i}, x_{r_i}, y_{r_i}, z_{r_i}\}$ where $i = 1, \dots, 4$ and are parallel to the body-fixed frame.

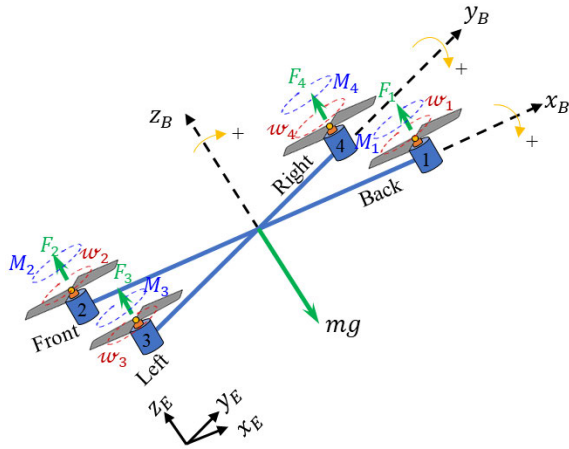

FIGURE 8. Thrust, moment, and rotational speed of each rotor in the quadcopter.

In this study, the dynamics of the quadcopter model were obtained based on the *Newton-Euler* method as it is deemed more suitable for modeling based control [19].

2) SIMPLIFICATION ASSUMPTIONS

The quadcopter model was derived based on the following assumptions [19]:

- The quadcopter model is rigid and symmetrical.
- The center of gravity of the quadcopter model coincides with the body-fixed frame origin.
- The propellers of the rotor are inflexible (no flapping blade).
- Thrust and drag are proportional to the square of the propeller’s speed.
- The axes of the quadcopter coincide with the axes of the body-fixed frame.

The quadcopter is a six DOF system and has two sub-systems; the translational sub-system that describes its position (x, y, z) and the rotational sub-system which describes its orientations (ϕ, θ, ψ). The quadcopter model is considered an underactuated system as it has four independent control inputs used to control the six DOF motions.

Consider a quadcopter is represented by a mass m . Based on *Newton’s* second law, the translation motions of the quadcopter, that is described in the body frame, is obtained by considering its forces F , described in earth frame by:

$$F^E = m \frac{d}{dt}(V^E) \tag{13}$$

It is more practical to express equation (13) in terms of the body-fixed frame. To achieve this, the *Coriolis* equation that relates the vector derivatives at two distinctive frames through an angular velocity vector, ω is used to describe the angular rotation of the body-fixed frame with respect to the earth fixed frame [31].

Therefore $\sum F^B$ will be as follows:

$$\sum F^B = m\dot{v}^B + \omega^B \times (m\dot{v}^B) \tag{14}$$

where ω is the angular velocity vector and equation (14) is the non-linear translational motion.

For the rotational sub-system, the angular momentum of a body with inertia matrix J is described in earth frame as follows:

$$M^E = J \frac{d}{dt}(\omega^E) \tag{15}$$

Similar to the expression described for the forces in equation (14), the *Euler* equations may be described in the body-fixed frame to provide the rotational motion. Therefore $\sum M^B$ can be expressed as:

$$\sum M^B = J\dot{\omega}^B + \omega^B \times (J\omega^B) \tag{16}$$

3) DYNAMICS OF QUADCOPTER

a: TRANSLATIONAL EQUATIONS OF MOTION

Based on equation (14), with reference to **Figure 8**, and the assumption that the perturbations are small when the quadcopter hovers at a lower height, therefore the translation equations of motion based on *Newton’s* second law are as follows [30]:

$$\sum F^B = m\dot{v}^B \tag{17}$$

$$m\dot{v}^B = \begin{bmatrix} 0 \\ 0 \\ -mg \end{bmatrix} + RF_{ng} + D - F_d \tag{18}$$

$$F_{ng} = \begin{bmatrix} 0 \\ 0 \\ F_1 + F_2 + F_3 + F_4 \end{bmatrix} = \begin{bmatrix} 0 \\ 0 \\ K_F(\omega_1^2 + \omega_2^2 + \omega_3^2 + \omega_4^2) \end{bmatrix} = \begin{bmatrix} 0 \\ 0 \\ U_1 \end{bmatrix} \tag{19}$$

where,

- m : mass of the quadcopter
- F_{ng} : non-gravitational forces acting on the quadcopter
- F_d : drag forces, $[k_1\dot{x} \ k_2\dot{y} \ k_3\dot{z}]^T$; where, $k_1, k_2,$ and k_3 are the aerodynamic translational coefficients
- D : disturbances, $D = [d_1 \ d_2 \ d_3]^T$
- K_F : aerodynamic force coefficient
- U_1 : altitude control input
- w_i : rotational speed of rotor i

After rearrangement, the translational equations of motion are given by [29]:

$$\ddot{x} = \frac{U_1}{m} (c\phi s\theta c\psi + s\phi s\psi) - k_1\dot{x} + d_1 \tag{20}$$

$$\ddot{y} = \frac{U_1}{m} (c\phi s\theta s\psi - s\phi c\psi) - k_2\dot{y} + d_2 \tag{21}$$

$$\ddot{z} = \frac{U_1}{m} (c\phi c\theta) - g - k_3\dot{z} + d_3 \tag{22}$$

It is obvious that the translational subsystem is underactuated and depends on both the translational and rotational state variables as shown in **Figure 9**.

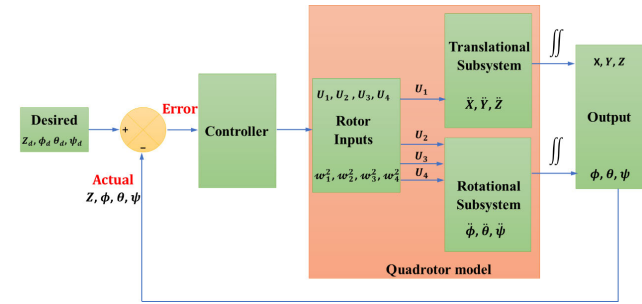

FIGURE 9. Schematic block diagram of a quadcopter.

b: ROTATIONAL EQUATIONS OF MOTION

By using the *Newton-Euler* method and with reference to **Figure 8**, equation (16) can be expressed as [30]:

$$J\dot{\omega} = [M_{Dis} + M - M_G - M_{Ar}] - \omega \times J\omega \quad (23)$$

$$F_i = K_F \omega_i^2 \quad (24)$$

$$M_i = K_M \omega_i^2 \quad (25)$$

where,

J : diagonal inertia matrix,

$$J = \begin{bmatrix} I_{xx} & 0 & 0 \\ 0 & I_{yy} & 0 \\ 0 & 0 & I_{zz} \end{bmatrix};$$

I_{xx} , I_{yy} , and I_{zz} are the moments of inertia about the principal axes in the body frame, and $I_{xy} = I_{xz} = I_{yx} = I_{yz} = I_{zx} = I_{zy} = 0$, since the quadcopter structure is symmetric

ω : angular velocity vector in the body frame,

$$\omega = \begin{bmatrix} \dot{\phi} \\ \dot{\theta} \\ \dot{\psi} \end{bmatrix} \text{ and } \dot{\omega} = \begin{bmatrix} \ddot{\phi} \\ \ddot{\theta} \\ \ddot{\psi} \end{bmatrix}$$

M_{Dis} : random disturbance moment

M : moments acting on the quadcopter in the body frame

M_G : gyroscopic moments due to rotors' inertia and can be expressed as:

$$M_G = \omega \times \begin{bmatrix} 0 \\ 0 \\ J_r \omega_r \end{bmatrix} \quad (26)$$

- J_r is the rotor inertia constant.
- ω_r is the rotor relative speed,

$$\omega_r = \omega_1 + \omega_2 - \omega_3 - \omega_4$$

M_{Ar} : air friction moment

K_M : aerodynamic moment coefficients

Note that, ω_i is the rotational speed of rotor i , while ω is the angular velocity vector in the body frame and w is the linear velocity in z_B axis in the body frame.

Each rotor causes an upward force (lift F_i) and a moment, M_i with direction opposite to the rotational speed of the rotor, ω_i . Propellers 1 and 2 rotate in the same direction (CW) while Propellers 3 and 4 rotate in the other direction (CCW) leading to stability in the entire model, balance in the overall torque, and cancelation of the gyroscopic and aerodynamics torques in stationary flights, as shown in **Figure 8**.

The total moment in x , y , and z directions are given by:

$$M = \begin{bmatrix} lK_F(\omega_3^2 - \omega_4^2) \\ lK_F(\omega_2^2 - \omega_1^2) \\ K_M(-\omega_1^2 - \omega_2^2 + \omega_3^2 + \omega_4^2) \end{bmatrix} = \begin{bmatrix} lU_2 \\ lU_3 \\ U_4 \end{bmatrix} \quad (27)$$

where, l is the moment arm, which is the distance between the center of the rotor and the center of gravity of the body frame. U_2 , U_3 , and U_4 are the rolling, pitching, and yawing control inputs, respectively.

Therefore, by substitution into equation (23), the rotational equations of motion are given by [29]:

$$\ddot{\phi} = M_{dp} + \frac{lU_2}{I_{xx}} - \frac{\dot{\theta}J_r\omega_r}{I_{xx}} + \dot{\psi}\dot{\theta} \left(\frac{I_{yy} - I_{xx}}{I_{xx}} \right) - k_4\dot{\phi} \quad (28)$$

$$\ddot{\theta} = M_{dq} + \frac{lU_3}{I_{yy}} + \frac{\dot{\phi}J_r\omega_r}{I_{yy}} + \dot{\psi}\dot{\phi} \left(\frac{I_{zz} - I_{xx}}{I_{yy}} \right) - k_5\dot{\theta} \quad (29)$$

$$\ddot{\psi} = M_{dr} + \frac{U_4}{I_{zz}} + \dot{\phi}\dot{\theta} \left(\frac{I_{xx} - I_{yy}}{I_{zz}} \right) - k_6\dot{\psi} \quad (30)$$

where

- k_4 , k_5 , and k_6 : the aerodynamic friction coefficients
- M_{dp} , M_{dq} , and M_{dr} : the random disturbance moments

The relationship between the control laws and angular speeds of the four rotors, from equations (19) and (27) is given as:

$$\begin{bmatrix} U_1 \\ U_2 \\ U_3 \\ U_4 \end{bmatrix} = \begin{bmatrix} K_F & K_F & K_F & K_F \\ 0 & 0 & K_F & -K_F \\ -K_F & K_F & 0 & 0 \\ -K_M & -K_M & +K_M & +K_M \end{bmatrix} \begin{bmatrix} \omega_1^2 \\ \omega_2^2 \\ \omega_3^2 \\ \omega_4^2 \end{bmatrix} \quad (31)$$

Thus, to get the angular speeds as a function of the control laws, the inverse of equation (31) needs to be obtained.

It is obvious that the rotational subsystem is fully actuated and depends only the state variables $x_1 \rightarrow x_6$ that correspond to $[\phi \ \dot{\phi} \ \theta \ \dot{\theta} \ \psi \ \dot{\psi}]$, as shown in **Figure 9**.

By linearizing the dynamic system around an operating point, the linear model of the quadcopter is given by [32]:

$$\begin{aligned} \ddot{\phi} &= \frac{lU_2}{I_{xx}} \\ \ddot{\theta} &= \frac{lU_3}{I_{yy}} \end{aligned}$$

$$\begin{aligned} \ddot{\psi} &= \frac{U_4}{I_{zz}} \\ \ddot{z} &\approx \frac{U_1}{m} - g \end{aligned} \quad (32)$$

III. CONTROL STRATEGIES

Rotorcraft systems are multi-variable, non-linear, and highly coupled systems. While performing certain missions, they face many challenges such as obstacles, external disturbances, parametric and non-parametric uncertainties, etc. Therefore, designing a robust and efficient controller is of significant interest to stabilize the rotorcraft systems and improve their performances in either normal or complex environments. Usually, the proposed control strategies present acceptable results in the ideal case however indeed there are differences in their performance and effectiveness on dynamic systems. Thus, to reach the best performance of the control systems, there are some analysis tools used to assess and optimize them, such as [19], [33]:

- Integral Squared Control Input (ISCI), $ISCI = \int_{t_0}^{t_f} u^2(t) dt$
- Integral Squared Error (ISE), $ISE = \int_{t_0}^{t_f} e^2(t) dt$
- Mean Absolute Error (MAE), $MAE = \int_{t_0}^{t_f} |e|(t) dt$
- Integral Time Squared Error (ITSE), $ITSE = \int_{t_0}^{t_f} te^2(t) dt$
- Integral Time Absolute Error (ITAE), $ITAE = \int_{t_0}^{t_f} t|e|(t) dt$
- Maximum Absolute Error (MAE), $MAE = \max|e|$
- Error Variance (EV)
- $O = Ae + Bt_{st} + CM_{Po}$, where e , t_{st} , and M_{Po} , are steady-state error, settling time, and percent overshoot, respectively, A , B , and C are positive constants and O is the objective/fitness functions.

In the next sections, a state-of-the-art review of the various control strategies that have been conducted to control the rotorcraft systems exposed to different impediments is presented as the most commonly used types of controllers are shown in **Figure 10**. In this study, the rotorcraft UAVs were divided into three categories, namely, the twin-rotor (i.e., twin-rotor system or 2-DOF helicopter), quad-rotor (or quadcopter), and multi-rotor (i.e., more than four rotors such as hexacopter, octocopter, decacopter, etc.) systems.

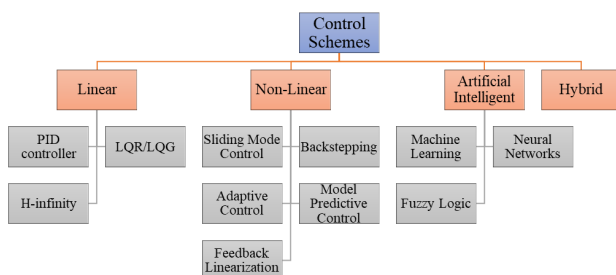

FIGURE 10. Control systems classifications.

A. TWIN-ROTOR SYSTEMS

Starting with linear controllers, one of the most common control systems in this category is the proportional-integral-derivative (PID). It is the most popular control unit in the industry because of its simplicity, ease of design, and ability to provide a preliminary satisfactory performance with relatively minimal control efforts [34]. The essential matter in designing a PID controller is the proper selection or tuning of its gains, i.e., the proportional term (K_P) which expresses the present error, the integral term (K_I) which describes the accumulated past error, and the derivative term (K_D) which predicts the future error. They can be tuned using a trial-and-error method (TEM) or any optimization algorithms.

The PID controller has been proposed for the TRMS (twin rotor MIMO system) wherein it can be combined with other complementary algorithms to enhance its behavior. Maiti *et al.* [35] proposed, via systematical and experimental means, a particle swarm optimization (PSO)-based PID controller in addition to utilizing a cross-coupling technique for reaching the desired position without any unwanted movements during trajectory tracking. Pandey *et al.* [36] also implemented, analytically and practically, a robust PID controller tuned using a bacterial foraging optimization (BFO) method, to solve the stabilizing problem of a twin-rotor helicopter subjected to actuator nonlinearity, disturbances, and uncertainties, on the basis of *Kharitonov* robust stability criteria. However, PID compensation is unsuccessful to reject various types of disturbances or model uncertainties and its performance is strongly influenced by the coupling effect as well.

One of the recent methods that drew attention and is considered more effective than the conventional PID controller is a fractional-order PID (FOPID). The difference between the conventional PID and FOPID is as follows:

The ideal form of a PID controller in the time domain is:

$$u(t) = K_P e(t) + K_I \int_0^t e(\tau) d\tau + K_D \frac{de}{dt} \quad (33)$$

Or in another form:

$$u(t) = K_P + \frac{K_I}{s} + K_D s \quad (34)$$

However, the difference in the FOPID is:

$$u(t) = K_P + \frac{K_I}{s^\lambda} + K_D s^\mu \quad (35)$$

If $\lambda = \mu = 1$, then it is considered a description of the classical PID controller, as shown in **Figure 11**. The FOPID reveals better efficacy against disturbances and model uncertainties while PID exhibits limited ability to reject disturbances [37]. However, the point of concern about FOPID is the proper estimation of the FOPID's gains. In the work done by [38], the study utilized the sequential quadratic programming (SQP) optimization algorithm to optimize the FOPID control parameters for a dual-rotor helicopter subjected to strong non-linear and coupling effects. The results showed the FOPID controller outperformed

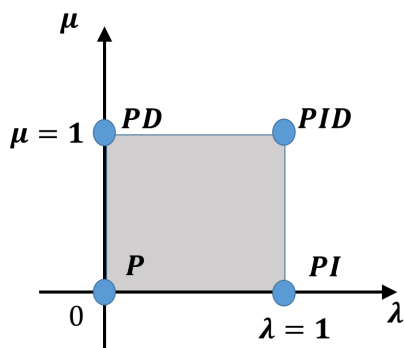

FIGURE 11. The difference between PID and FOPID.

the standard PID counterpart. Ates *et al.* [39] also presented, experimentally and numerically, a model-independent fine-tuning FOPID controller, for a double-rotor helicopter, using master-slave stochastic multi-parameters divergence optimization (SMDO) strategy where the results demonstrated the effectiveness of the suggested strategy in adjusting the reference model and FOPID and allowing more fitting without prior knowledge of the model assumptions simultaneously. Moreover, Ijaz *et al.* [40] designed a FOPID controller adjusted using *Nelder Mead* (NM) optimization method and it turned out to be more effective when compared with FOPID tuned using PSO, and the traditional PID controller as well. However, the proper tuning of FOPID controller gains poses a problem in the case of multi-DOFs systems.

The linear quadratic regulator (LQR) is also a linear control system used to control the attitude and position tracking of the helicopter system. Almtireen *et al.* [41] proposed three linear control designs which are full state feedback (FSF), LQR, and standard PID, and the results showed better performance for LQR at the expense of greater control effort. In another study, Choudhary [42] studied the optimal control design of a LQR control unit with a prescribed degree of stability and the simulated results showed satisfactory tracking performance.

Another linear controller that has caught the attention in TRMS control is the H_∞ control method. Pazera *et al.* [43] implemented, empirically, a new robust sensor-fault tolerant control scheme composed of a robust state and fault estimator and a H_∞ controller to solve sensor problems. Further, Witczak *et al.* [44] introduced a novel robust state and fault estimation design in the presence of external disturbances and unknown inputs, using the H_∞ approach to achieve a certain level of attenuation with observer convergence. However, the H_∞ controller needs a high level of mathematical treatment with poor robustness.

Several research works have been carried out using the non-linear controllers for the helicopter system. In this case, *Lyapunov* functions are utilized to ensure stability as *Lyapunov's* theorem is the basis for designing backstepping control (BC) and sliding mode control (SMC) methods. For BC, Huang *et al.* [45] displayed, practically and

systematically, a model-free backstepping (MFBS) control scheme to solve the problems of model uncertainties, coupling effects, and time-varying parameters of a 2-DOF helicopter system where the results showed the superiority of the MFBS compared to LQR controller. Haruna *et al.* [46] also proposed a new adjusted dual boundary conditional integral BC to achieve stability, efficient asymptotic output regulation without degrading the transient execution, accurate trajectory tracking, and precise attainment of a specific position. Moreover, Rashad *et al.* [47] proposed, empirically and numerically, a new non-linear control structure based on an integral BC approach with disturbances observers, and filtering extension for a double-rotor helicopter system in the presence of external disturbances and uncertainties. The effectiveness and strength of the suggested control unit were demonstrated in improving trajectory tracking in complex environments or any arbitrary paths with the ability to reject any external constant disturbances in case of partial failure in the actuator.

Regarding SMC, Rojas-Cubides *et al.* [48] suggested a robust control scheme combining a first-order SMC approach with a high-order generalized proportional integral (GPI) observer to handle fault and parametric uncertainties, nonlinearities, and external disturbances, and verified simulation results experimentally on a 2-DOF helicopter where the proposed controller showed good results in terms of robustness and disturbance rejection capability. Faris *et al.* [49] demonstrated the real-time implementation of a decentralized SMC for a TRMS that revealed the efficacy and robustness of the proposed controller in stabilizing and efficiently rejecting the external disturbances. Rashad *et al.* [50] investigated, experimentally and analytically, a robust tracking controller for a helicopter system subjected to external disturbances and model uncertainties with a partial failure in the actuator, by utilizing integral sliding mode disturbances observer SMC (SMDO-SMC). The results exhibited that the suggested control approach could provide less tracking error with lower control action and effective behavior due to parametric uncertainty. Rakhtala and Ahmadi [51] designed a second-order SMC to handle the pitch and yaw angles of a TRMS in the presence of model uncertainties, noises, and external disturbances where results indicated the effectiveness of the proposed control structure in reducing the tracking errors and rate of fluctuations with no chattering effect.

In regards to adaptive control, Kulkarni and Purwar [52] proposed a new adaptive non-linear gain based composite feedback controller (AND-CNF) for a 2-DOF helicopter system under input saturation for improving the system dynamic response. The results revealed the efficiency of the suggested control scheme in improving the settling time and root mean square error (RMSE) with acceptable overshoot and tracking of the desired paths as well. Moreover, Kavuran *et al.* [53] demonstrated both experimentally and analytically, the implementation of a fractional-order adjustment rule-based model reference adaptive control (FOAR-MRAC) strategy combined with the standard PID

controller to a twin-rotor helicopter model, by modifying the model approximation error utilizing a piecewise linear, near-zero dead zone function. Roman *et al.* [54] applied the data-driven model-free adaptive control (MFAC), model-free control (MFC), and virtual reference feedback tuning (VRFT) strategies for controlling a dual rotor aerodynamic model.

For the feedback linearization (FBL) approach, Xin *et al.* [21] proposed an input-output feedback linearization tracking control method for controlling a 2-DOF helicopter model by utilizing improved resetting and overlapping implementation of an algebraic differential estimation strategy. Both the simulation and experimental results showed better performance and precise trajectory tracking of the proposed control strategy when compared to the LQR controller. Pandey *et al.* [55] also presented an adaptive control method-based feedback linearization strategy, to solve the poor convergence, large transient responses, and uncertainties in the TRMS performance. In this work, it was shown an improvement in transient behavior, steady-state error, and tracking response. Furthermore, Chi [56] suggested an adaptive feedback linearization controller both practically and analytically to solve the tracking problem of the helicopter system in the presence of external disturbances and uncertainties with flexible dynamics, non-linearities, and cross-coupling effect. The results showed the robustness and effectiveness of the proposed controller in improving the paths tracking capability and accuracy.

From the previous discussion, the BC scheme efficiently eliminates the steady-state error while the SMC provides less tracking error with lower control action and higher efficiency in rejecting the parametric uncertainty. Further, the non-linear controllers are clearly effective in improving the tracking responses efficiently considering different loading and operating conditions. However, applying *Lyapunov* functions does not always give good performance and accuracy, and the use of non-linear controllers may lead to adverse effects such as chattering, oscillations, and noises. Ilyas *et al.* [57] designed first-order SMC and BC schemes to deal with the oscillations and chattering in pitch and yaw angles where BC shows better results in handling them compared to SMC. Concerning the strong cross-coupling effect and non-linearity between the main and tail rotors, Raghavan and Thomas [58] presented a model predictive control (MPC) design, via systematic and experimental means. The results revealed its ability to reject these effects and provide better performance compared to the SMC and PID controllers.

With the expansion of artificial intelligence (AI), many researchers employed it individually or in conjunction with other control systems to enhance the performance of rotorcraft systems. One such innovative intelligent control strategy is iterative learning control (ILC) or the so-called betterment process which is a type of adaptive intelligent control that acts smartly to enhance automatic control systems and achieve better performance in reference tracking. It is based on improving the transient response of dynamic systems that operate repetitively over a fixed time interval [59]. It also

enhances the system performance by utilizing the prior information of the previous iterations [60], as shown in **Figure 12**.

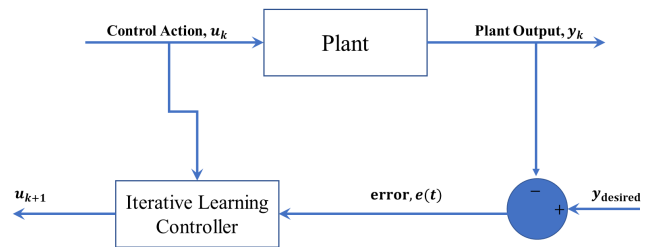

FIGURE 12. The schematic diagram of the iterative learning method.

In the work done by [61], ILC was applied to a double-rotor helicopter system both numerically and experimentally, to achieve higher efficiency in trajectory tracking. ILC is considered one of the more promising intelligent and adaptive methods as it features ease of design and implementation characterized by its inherent simple and linear algorithms and its ability to adjust its control parameters automatically and on-line. This is in contrast with some other seemingly advanced control techniques that involve complex mathematical treatment and require tuning of their parameters typically in an off-line mode, thereby deemed posing some difficulties for real-time implementation in real-world applications.

In the meantime, fuzzy logic (FL) and artificial neural network (ANN)-based artificial intelligent systems are promising computational tools because they rely on training experience and continuous learning ability [13]. Behzadimanesh *et al.* [62] designed an observer-based optimal-fuzzy state feedback controller for discrete-time *Takagi-Sugeno* fuzzy (TSF) system via LQR based on non-monotonic *Lyapunov* function, and compared its capability, experimentally, with the optimal fuzzy feedback controller design based on common quadratic *Lyapunov* function to achieve relaxed stability conditions with less conservatism. It is deduced that the control method based on non-monotonic *Lyapunov* function is more effective to track the reference and reject disturbances than the common *Lyapunov* function, however, at the expense of a little more control effort. Roman *et al.* [63] proposed a hybrid control strategy that includes a second-order data-driven model-free control (MFC), PI controller, and TSF controller. They showed that the control system with the MFC-TSF algorithm outperforms the conventional MFC algorithm-based controller. In other work, the entropy-based optimized FL control (FLC) tuned using the genetic algorithm (GA) method was studied experimentally and its efficacy was compared with the traditional PID controller [64]. The obtained results implied a substantial enhancement in the reference tracking capability for the twin-rotor helicopter system. Meanwhile, Zeghlache and Amardjia [65] proposed a control scheme combined the FLC with the SMC where the results showed the effectiveness of the proposed controller in reaching the desired position and attenuating the chattering effect efficiently.

For the ANN, Dheeraj *et al.* [66] analyzed analytically, the adequacy and achievability of a direct adaptive control law via a radial basis function (RBF) neural network utilizing the FBL approach on affine non-linear systems such as TRMS in the absence of comprehensive information where the outcomes implied the superiority of this approach in developing suitable control law for the MIMO systems without any knowledge of non-linearities. Lin *et al.* [67] also proposed a new control structure combining the FBL method and feed-forward neural network control to solve the tracking problem of the twin-rotor helicopter with disturbance decoupling capability. The simulated results showed the efficiency of the proposed methodology in improving the desired tracking and disturbance decoupling performance. Agand *et al.* [68] demonstrated, experimentally the efficiency of using an adaptive neural network based inverse dynamic control (IDC) for a helicopter system. In this work, an enhancement in the steady-state performance of two to three times compared to the conventional PID was exhibited. It is obvious that the FLC and ANN-based methods show reductions in the tracking error and weight drift; however, they need several simplifications in the model dynamics to reduce the computational power and pre-knowledge for initialization.

B. QUAD-ROTOR SYSTEMS

Numerous linear, non-linear, and intelligent control systems have been implemented both analytically and experimentally, to control the quadcopter system in the wake of a number of difficulties encountered.

Many research works employed the conventional PID controller to stabilize the quadcopter system, individually or in combination with other sub-control units to improve its capability in different operating conditions. PID gains can be adjusted using TEM [69], a look-up table such as *Ziegler-Nichols* (ZN) [28], or any optimization technique including the GA [19], [29], [70], and PSO [71]–[73]. Putra *et al.* [74] proposed a PID controller tuned using the fast GA technique where results demonstrated its superiority over the conventional GA in speeding up the optimizing generation achievement and reducing the simulation execution time. Hasseni *et al.* [75] carried out a comparative study of a PID controller based on stochastic nature-inspired algorithms of GA, evolution strategies (ES), differential evolutionary (DE), and cuckoo search (CS) to control a quadcopter according to a reference tracking task. The success of the GA and ES in obtaining the best path tracking was revealed. However, the ES controllers had rotational sensitivity. In the work done by [76], a comparative study was performed based on the optimal PID controller tuned using PSO, BFO, or PSO-BFO techniques to analyze the system output responses. It was observed that the PSO-BFO-based PID strategy performed better than other control schemes considered in the study. Moreover, the AI methods can be utilized for tuning the PID gains.

Integrating the intelligent system with the PID control, Dong and He [77] designed a new control strategy that

combined the PID-ILC and FLC to reject the applied disturbances and model uncertainties. The results demonstrated the effectiveness of the suggested strategy in improving the performance of the dynamic system in the presence of small or large lumped disturbances, or external wind gusts. In addition, FL can be used to tune the PID control parameters in case of a sudden change in the dynamic system parameters for varied operating and loading conditions [78], [79]. Demir *et al.* [80] applied the attitude control and real-time trajectory tracking of a UAV through the use of a self-tuning (ST) fuzzy-PID controller. The results demonstrated its outstanding performance in reducing the reference tracking error compared to the conventional PID.

One of the innovative strategies used to control the quadcopter system is the FOPID which is the generalized form of the standard PID controller but deemed to have much better performance, stability, and robustness [81]. Shi *et al.* [82] presented a fractional-order backstepping SMC method for a quadcopter system. The efficacy of the planned scheme in reducing the chattering effect and improving reference tracking performance in the presence of complex paths accompanying disturbances has been demonstrated. Further, Ayad *et al.* [83] studied full control of a quadcopter aircraft using a FOPID control scheme, taking into account the gyroscopic and non-linear effects. Han *et al.* [84] also designed a fractional order PI controller to control the pitch loop of a quadcopter subjected to a wind gust. However, the effectiveness of the FOPID was not experimentally validated without considering the external disturbances and model uncertainties to verify the sensitivity of the proposed strategy.

Other popular linear control systems used to control the quadcopter system are the LQR and linear quadratic *Gaussian* (LQG) with their performance compared to other control strategies. Fessi and Bouallègue [85] discussed the modeling and control of a quadcopter model using a PSO-based LQG controller. The results implied the superior behavior of the proposed strategy in terms of fastness convergence, solutions quality, and exploitation capabilities in comparison to other algorithms. Additionally, Du *et al.* [86] proposed a new distributed consensus formation control algorithm based on the LQR optimal control and finite-time control theory to solve the distributed formation flying control problem for a group of quadcopter aircraft under a leader-following structure. The results revealed the effectiveness of the control strategy in converging all the quadcopter models to the required formation pattern in 3D space. Meanwhile, Smirnova and Smirnov [87] examined two diverse methods which are the PID and LQR methods applied to a quadrotor system. They demonstrated that the LQR controller was more robust and caused a low steady-state error though at the expense of a high transition time.

Other researchers implemented the H_∞ controller for the quadcopter system because of its robustness in rejecting the model uncertainties and external disturbances. Noormohammadi-Asl *et al.* [88] suggested a H_∞ controller for a quadcopter model to cope up with the unmodeled

dynamics and unknown parameters. The experimental results indicated the robustness of the designed controller in providing better tracking performance compared to a well-tuned PID and μ synthesis controllers. Wang *et al.* [89] also proposed a H_∞ attitude tracking control scheme for a quadcopter UAV to implement a large angle flip and complex flight maneuvers. The ability of the proposed controller to reject the applied disturbances and improve robustness was shown via a simulation study. Further, Li *et al.* [90], presented a robust H_∞ fault-tolerant control strategy to regulate the attitude of a quadcopter system exhibiting the efficacy of the proposed controller in stabilizing the aerial vehicle with rapid response and small fluctuations while at the same time, efficiently attenuating the applied disturbances. Ortiz *et al.* [91] developed a robust H_∞ -PID controller both in simulation and experimental works, for attitude and rotational moments regulation in the presence of unmodeled dynamics and uncertainties. The performance showed more effectiveness and robustness of the proposed scheme when benchmarked against the conventional PID controller.

The development and implementation of non-linear control systems have become a necessity, due to the realistic and inherent non-linearities in the real-world dynamic systems and the need to deal with a wide range of operating and loading conditions that cannot be adequately handled and covered by linear controllers. SMC has been employed for controlling the quadcopter model due to its insensitivity to modeling errors, disturbances, and uncertainties. Maqsood and Qu [92] developed a novel non-linear disturbance observer integrated with a gain scheduled SMC for a quadcopter subjected to parametric uncertainties and exogenous disturbances. The effectiveness of the developed control system in improving the disturbance rejection capability, accommodating parametric variations, and retaining nominal tracking performance was shown. Wang *et al.* [93] also presented a dual-loop integral sliding mode attitude controller based on linear extended state observer (LESO) to solve the trajectory tracking problems in the quadcopter subjected to external disturbances and uncertainties. The experimental and simulation results revealed the efficiency and strength of the designed control strategy in enhancing the reference tracking performance and disturbances rejection capability. In another similar study, Sanwale *et al.* [94], proposed a robust non-linear position and attitude control methods based on a quaternion based third-order SMC paired with a low pass filter and disturbance observer for a quadcopter position control. The efficacy of the suggested controller was illustrated to reject continuous disturbances and model uncertainties with position accuracy up to a millimeter margin. Rios *et al.* [95] also introduced experimentally a robust tracking output-control strategy integrating a finite-time sliding-mode observer (FT-SMO) with a combination of PID controllers and three continuous SMC controllers for a quadcopter model subjected to external disturbances and uncertainties. It was shown that the proposed strategy improved the desired trajectory with good precision in the presence of

uncertainties of the system. However, the proposed scheme was not benchmarked against other robust control strategies.

It should be noted that the chattering phenomenon is the major negative predicament in SMC and the best design should effectively address and resolve it. Eltayeb *et al.* [96], introduced an improved integral SMC strategy with a satisfactory reduction in chattering for the attitude (inner) loop control while a conventional PD controller was proposed for the position (outer) loop control of the quadcopter model. Perozzi *et al.* [97] studied ways to address the difficulties of position tracking, reduce the chattering effect, and handle the rotor dynamics in the quadcopter UAV in the presence of wind perturbation by applying a robust SMC method. The results indicated the effectiveness of the proposed controller in stabilizing the aerial system under varying wind load. Chang *et al.* [98] used smooth and adaptive second-order SMC algorithms for estimating the roll and pitch angles of a quadcopter model in the presence of some bias and noises. Both algorithms produced agreeable time convergence and good overall performance. Fractional order can also be employed for non-linear controllers, such as the fractional-order SMC (FOSMC) to ensure robust tracking stability in the presence of external disturbances and model uncertainties [99].

Another nonlinear control system that has been used for the non-linear quadcopter is the BC approach [100]–[103]. Liu *et al.* [104] studied the formation control problem for a group of quadcopters subjected to underactuated, highly non-linear, strongly coupled dynamics, and disturbances using a distributed robust controller consisting of position controller and attitude controller and based on robust compensation theory and the backstepping technique. The results showed the effectiveness of the proposed controller in achieving good tracking performances with robust stability. Xuan-Mung and Hong [105] presented a novel robust extended state observer (ESO) based backstepping tracking control scheme for a quadcopter model in the presence of input saturation, disturbances, and uncertainties. The results indicated the effectiveness of the proposed controller in improving the reference tracking performance, rejecting uncertainties and disturbances while achieving fast response compared to the BC-based approaches. Saif *et al.* [106] also proposed a decentralized BC strategy optimized using the differential evolution method. It was shown that the proposed strategy could efficiently reject the external disturbances and achieve the decoupling of the motions. Meanwhile, Chovancová *et al.* [107] carried out a comparative study based on the PD, LQR, and BC methods for controlling the position of a quadcopter model by utilizing quaternion representation of the attitude in the presence of noise, actuator limitations, and streamlined unsettling influences. It is exhibited that some of the controllers revealed similar performance and behavior whereas the best performance is achieved by using the backstepping attitude controller.

Regarding the FBL strategy, it has been employed to transform the non-linear quadcopter model, either partly or

completely into a linear system. Hu and Lanzon [108] utilized a robust FBL to control both the translational and rotational motions independently and accomplish the most noteworthy of maneuverability. Alkamachi and Erçelebi [109] introduced an optimal H_∞ controller with FBL method to control an overactuated tilt-rotor quadcopter. This scheme yielded better execution performance than the traditional quadcopter control configuration, delicate traceability of the complex route, and much-improved controllability. Zhang *et al.* [110] also presented the standard PID controller with feedforward control and FBL using the backstepping strategy for a quadcopter in the presence of actuator dynamics and aerodynamic impact and further experimentally applied it in an indoor environment. The robustness of the proposed scheme in the moving target tracking control was clearly displayed in this study.

The MPC is an advanced non-linear control system that largely depends on predicting the future states of the system and simultaneously tracking the errors to improve the performance of the dynamic system [30]. MPC has also been used for controlling the quadcopter system [111]. Eskandarpour and Sharf [112] proposed a linear constrained MPC scheme to resolve the trajectory tracking problem for a quadcopter experiencing external disturbances. Its efficacy in improving the disturbance rejection capability, fast reference tracking, and achieving stability with the desired performance was positively implied. Williams *et al.* [113] also developed a model predictive path integral control algorithm based on a generalized importance sampling for a quadcopter moving within a troublesome (complex) environment where the results of the study showed its effectiveness and robustness to a greater extent against the conventional optimal controller. Additionally, Lu *et al.* [114] proposed an anti-disturbance control utilizing MPC with inputs limitations and states using anti-disturbance control which was an effective combination of a disturbance observer and H_∞ control to considerably increase the system robustness against numerous disturbances while making positive strides considering constriction capacities.

For the adaptive control domain, Eltayeb *et al.* [115] presented an adaptive FBL method for a quadcopter model in the presence of external disturbances and model uncertainties in which the results showed a substantial decrease in attitude and altitude errors to around 82% and 53%, respectively, compared to the conventional FBL scheme. Huang *et al.* [116] developed a robust adaptive SMC structure for altitude and attitude tracking control of a quadcopter against external disturbances and parametric uncertainties. The simulation results implied the success of the proposed control strategy in eliminating the tracking error, while the experimental results demonstrated its superiority and robustness in tracking performance compared to the conventional LQR and active disturbance rejection control (ADRC) systems. In the work done by [117], the study proposed a novel adaptive SMC (ASMC) for finite-time stabilizing of a quadcopter aircraft subjected to parametric uncertainties. In this

work, the ability of the ASMC-based controller to improve the finite-time tracking and stability of the quadcopter system was revealed. Kun and Hwang [118] also suggested a novel linear matrix inequality-based adaptive robust control to regulate the attitude and position control of an X-configuration quadcopter model. In this work, its efficacy against the external disturbances, unmodeled dynamics, and uncertainties without any loss in performance was demonstrated. Further, Islam *et al.* [119] highlighted an observer-based adaptive output feedback control system for a quadcopter subjected to bounded uncertainty. The results showed that the tracking performance can be recovered asymptotically and the efficacy of the proposed strategy for real-time applications considerably improved as well. Islam *et al.* [120]–[122] introduced a *Lyapunov*-based robust adaptive SMC algorithm to solve the stability and tracking control problems of a miniature unmanned multirotor aerial vehicle (MUMAV) subjected bounded parametric uncertainty. The results revealed the effectiveness of the proposed control scheme for real-time applications and its ability to guarantee asymptotic stability and improved tracking control property.

The reliance on intelligent control methods to control quadcopter systems has found growing interest by researchers. Mahmoodabadi and Babak [123], presented a robust fuzzy controller based on the LQR technique and optimized it using multi-objective high exploration PSO (MOHEPSO) for a non-linear quadcopter. The effectiveness of the suggested scheme in reducing the overshoot, settling time, and improving robustness compared to the standard LQR controller was illustrated. Zhang *et al.* [124] also developed an adaptive fuzzy-based global SMC strategy to improve the trajectory tracking of a quadcopter UAV subjected to parameter uncertainties and external disturbances. The results showed its ability to eliminate the chattering effect and tolerate parameter uncertainties and external disturbances compared to the conventional SMC. However, the finite-time stability was not addressed in the design. Further, Hwang *et al.* [125] proposed, via experimental means, an extended Kalman filter-based fuzzy tracking incremental control (EKF-FTIC) for a quadcopter model to improve the on-line obstacle detection, avoidance, and mapping. The proposed scheme showed its effectiveness and robustness in dealing with the stochastic noise and dense obstacle avoidance environment. For a precise terminal landing phase, Al-Sharman *et al.* [126] developed a low cost adaptive fuzzy data fusion algorithm in which the results indicated an accurate adaptive altitude estimation and improvement in precise state estimating. Bounemour *et al.* [127] developed a novel active fuzzy fault-tolerant tracking control (AFFTTC) system for a non-linear quadcopter system and proved its efficacy in the presence of aerodynamic disturbances, actuator faults, sensor failures, and approximation errors.

Related to ANN, Xingling *et al.* [128] developed a neuro-adaptive integral robust controller image-based visual servo (IBVS) with minimal learning parameter (MLP) technology to solve the problem of visual tracking control of ground

moving target for a quadcopter UAV suffering from noises, uncertainties, and external disturbances. The results showed the superiority of the proposed control system by significantly improving the system performance in decreasing the image matching errors and providing a stable servo tracking with robust anti-disturbance capability. Moreover, Wang *et al.* [129] proposed backpropagating constraints-based trajectory tracking control (BCTTC) method to solve the trajectory tracking problem of a quadrotor model with complex unknowns and constrained actuator dynamics. The results indicated the effectiveness of the BCTTC in achieving high-accuracy trajectory tracking and its outperform without addressing inner nonlinearities or actuator constraints. Razmi and Afshinfar [130] also proposed an ANN-based adaptive SMC approach for a quadcopter subjected to external disturbances and parametric uncertainties with *Lyapunov* theory used to ensure stability. An enhancement was demonstrated in the transient and steady-state behaviors plus exhibiting insensitivity to parametric changes, and the ability to reject disturbances. Khosravian and Maghsoudi [131], presented a recurrent ANN-based non-linear PID control algorithm for attitude control and path tracking of a quadcopter system. In this study, the efficiency of the proposed control scheme in tracking the reference trajectory and stabilizing the attitude of the system simultaneously was demonstrated. Muliadi and Kusumoputro [132] also compared the effectiveness of ANN's direct inverse control (DIC-ANN) with the classical PID control system to control the attitude motion of a quadcopter model with the obtained results displaying viability and improved performance of the DIC-ANN compared to the PID counterpart. Fu *et al.* [133] presented an adaptive ANN backstepping dynamic surface control algorithm based on asymmetric time-varying barrier *Lyapunov* function to control the attitude sub-system of a quadcopter UAV in the presence of uncertainties, external disturbances, and output constraints. The results indicated its efficiency and robustness to track desired paths with high precision, stabilize the non-linear dynamic system, and bound all signals. In the meantime, Hatamleh *et al.* [134] conducted a comparative study based on three strategies: iterative bi-section shooting (IBSS), ANN, and Hybrid ANN-IBSS to determine the ambiguous parameters of a quadcopter model exposed to noise. The simulated results revealed that IBSS and ANN can evaluate the most unknown parameters even with noisy signals. however, their accuracy was inadequate in the case of small value parameters with the hybrid ANN-IBSS yielded better precision compared to other techniques.

In relation to adaptive learning, Bulucu *et al.* [135] introduced an on-line adaptive learning algorithm for robust adaptive non-linear auto-regressive moving average (NARMA) control strategy based on *Hammerstein*-based plant and *Wiener*-based controller models for twin rotor and quadcopter systems and verified them experimentally on the real TRMS subjected to cross-coupling effect. The results showed the ability of the proposed control scheme in ensuring closed-loop system stability, providing robustness against noise

and disturbances, and improving the tracking performance. Further, Mu and Zhang [136] developed a learning-based robust tracking control strategy using ANN for a quadcopter system subjected to time-varying and uncertainties. The simulated results yielded the effectiveness of the control method compared to the LQR controller. Ohnishi *et al.* [137] presented a safe learning framework that employs an adaptive learning algorithm with barrier certificates for a quadcopter UAV and *Brushbot* (a mobile robot with bristles or brush) with improvement ensured under mild conditions and the good efficacy of the proposed learning framework in real-time applications. Meanwhile, Alabsi and Fields [138] investigated the potential implementation of the recursive *Fourier* transform regression (FTR) method combined with a non-linear dynamic inversion (NDI) control for the *Learn-to-Fly* concept utilizing a quadcopter model. The results addressed the challenges during estimating the model parameters and introduced efficient integration between real-time modeling and control adaptation. Additionally, Liu *et al.* [139] applied experimentally and numerically, a learning rate based SMC for variable load altitude control of a quadcopter aircraft model. It was shown the effectiveness of the proposed control scheme in improving convergence and accuracy performance of the altitude tracking capability under large variable load disturbance and estimation efficiently.

There is a recent interest in using data-driven approaches based on machine learning (ML). A comprehensive review of the latest uses, applications, challenges, and methods of deep learning for UAVs was reported in [140]. Additionally, in the work done by [141], the different solved problems of wireless networks such as handover latency reduction, routing, link duration prediction, etc. were analyzed using machine learning-based prediction techniques, and further problems were also identified, to which these methods can be applied to them. Moreover, Kouhdaragh *et al.* [142] discussed the advantages and potentials of designing of UAVs-based radio access networks (RANs) (U-RANs) to improve the stringent requirements of 5G network using ML methods and specifically the supervised and reinforcement learning strategies. However, ML algorithms may perform poorly, or unexpectedly when the obtained solutions work on data that have characteristics different from those that used to train the model. While Mahajan *et al.* [143] developed a complete machine learning model from a new comprehensive dataset obtained using camera-equipped drones for predicting lane-changing and lane-keeping maneuvers, to enhance highway safety. The results demonstrated the efficiency of the proposed strategy in predicting the lane changes in real-time with an average detection time of at least 3 seconds with a small percentage of false alarms. however, the recorded data were obtained from a short highway segment and the use of velocity direction with respect to the reference frame needs further investigation. Moreover, in the work done by [144], a comprehensive deep learning methodology was proposed to generate an absolute or relative point cloud estimation of a digital elevation model (DEM) given a single satellite or

drone image for a wide range of applications and disciplines such as 3D flight planning, autonomous driving, and satellite navigation. Shan *et al.* [145] also formed a new method based on a machine learning approach to collect and share data among drones and other aircraft, analyze data and establish models, and capture more detailed characteristics about drone communications, which is useful for avoiding hazardous conditions. It was shown the effectiveness of the proposed strategy in being able to better create complex models with less effort to improve drone control. One of the applications of using machine learning data-driven approaches is precision agriculture such as in the work done by [146]. The paper displayed a data-driven methodology based on outdoor experiments to develop a mathematical model that can predict the distribution of pest treatment to optimize UAV-based delivery of natural enemies in the presence of wind and different conditions. Furthermore, Ferdaus *et al.* [147] presented a new online identification method, applied to a quadcopter model, and employing real-time empirical flight data streams based on metacognitive scaffolding learning machine (McSLM) to be known as metacognitive scaffolding interval type 2 recurrent fuzzy neural network (McSIT2RFNN) as results indicated significant improvements in both accuracy and complexity.

For a hybrid controller, Tang *et al.* [148] studied the design of a flight controller consisting of a hybrid control strategy comprising an optimal LQR and SMC strategies for a quadcopter model considering induced momentum, rotor blade distortion, and various aerodynamics effects, not only in hovering but also high speed and translational motion. The exceptional execution of the proposed controller for achieving better stability than the traditional control strategies was clearly demonstrated.

C. MULTI-ROTOR SYSTEMS

Due to payload limitations, lack of actuators redundancy in the quadcopter, and need for a stable, safer, and more powerful flight, hexacopter and octocopter are deemed the best solutions [149]. They are used in a wide range of applications such as mapping, accurate data acquisition, hyperspectral imagery [150]–[153], spectral data acquisition [154], aerial surveys [155], [156], pollutant open areas determination [157], and health monitoring [158].

Researchers have recently given more attention to the hexacopter and octocopter UAVs. Beginning with the PID controller, Božek *et al.* [159] proposed PID controllers tuned using the ZN method to control the attitude and altitude of the desired trajectory of a hexacopter system, configured with an automated arm that is subjected to aerodynamic and unsettling influences impacts. The results showed satisfactory behavioral performance, though not ideal. Alaimo *et al.* [160] also analyzed the responses of a hexacopter model by utilizing the LQR-tuned PD and PID controllers in which the results revealed that the suggested schemes could stabilize the perturbed structure rapidly at around an equilibrium position for about half a second.

For non-linear controllers and starting with SMC, Nguyen *et al.* [161] investigated experimentally a control strategy that integrates a *Thau* observer-based fault detection unit, and a SMC with disturbance observer-based altitude/attitude control system for a hexacopter subjected to actuator faults and disturbances. The results showed the efficacy of the control strategy in ensuring stability and safe flight even in the presence of one or two actuator failures. Lee *et al.* [162] and Lee and Kim [163] studied both analytically and empirically, the planning and controlling of a hexacopter UAV with a 2-DOF robotic arm, using an augmented adaptive SMC based on a closed-chain robot dynamic with a *Bezier* random tree star (RRT) and dynamic movement primitives (DMPs), for transporting an object in a certain trajectory with the ability to avoid obstacles in an unknown environment. The results displayed the effectiveness of the proposed controller strategy in avoiding the unknown obstacles and positively tracking the desired paths. Further, Yang *et al.* [164] demonstrated a solution for a failure in the motors system of a hexacopter by using SMC for outdoor flight tests. Zhang *et al.* [165] presented a robust BC strategy to solve the trajectory tracking problems of a hexacopter system due to the coupled characteristics in the presence of uncertainties and disturbances. The comparative simulations results showed the superiority of the proposed controller in performing the task. In another study, Lee *et al.* [166], developed a new attitude tracking control of a hexacopter UAV subjected to a failure in one or multiple rotors subjected to external disturbances by utilizing a time delay control strategy.

In this study, the superiority of the proposed strategy by adding durability and efficiency to the vehicle was illustrated when compared with the conventional PID control.

Ferdaus *et al.* [167] presented an adaptive control technique in the form of a model-free evolving controller called a parsimonious controller (PAC) based on an evolving neuro-fuzzy system known as parsimonious learning machine (PALM) architecture to solve the high degree of environmental perturbations for the bio-inspired flapping-wing micro aerial vehicle (BI-FWMAV) and hexacopter model in cluttered environments. The results revealed the effectiveness of the proposed strategy through various trajectory tracking performance tests compared to other controllers with its distinction, needing far fewer network parameters.

For hybrid control, Ferdaus *et al.* [168] proposed a novel self-evolving generic controller (G-controller) consisting of a generic evolving neuro-fuzzy inference system (GENEFIS) incorporating a SMC technique to handle the changes in the dynamics of a hexacopter aircraft without requiring any prior information. It was shown that the G-controller can change its system parameters on-line and effectively reject any unknown disturbances and uncertainties with satisfactory trajectory tracking capability.

Nguyen *et al.* [169] proposed a new cascaded control strategy based on the FBL method, to control the behavior of a hexacopter system to achieve safe tracking of predefined trajectories with the ability to avoid detected obstacles during

outdoor flight tests. The results indicated the efficacy of the suggested method for avoiding obstacles without getting stuck into local minima.

Further, Rosales *et al.* [170] proposed a novel and practical adaptive PID controller based on ANN designed in discrete time to alter the controller gains without any earlier knowledge of the model for trajectory tracking of a hexacopter that is subjected to outside disturbances and dynamic uncertainties. The suggested control scheme produced an excellent performance and has the ability to implement in any obscured and non-linear dynamic framework. Artale *et al.* [171] also carried out experimentally, a new real-time control strategy based on ANN to stabilize and track the reference trajectories of a hexacopter model. The results are seemingly and adequately promising for the planned control technique with regard to error measures and recreation of the hexacopter dynamics through its angular velocities.

D. NOVEL TECHNIQUES

In this section, the focus is more on discussing six impediments facing rotorcraft systems and possibly causing a failure in their fully entire dynamic system, namely, the external disturbances, slung load oscillations motion, non-trivial maneuvers, fixed and moving obstacles, faults, failures, or damages relevant to system components, and time-varying nature of the environment. Therefore, this study emphasizes the latest novel and innovative control techniques that have been proposed to efficiently solve these difficulties as described in the ensuing sections.

1) EXTERNAL DISTURBANCES

External disturbances including wind gusts are considered one of the major challenges facing rotorcraft UAVs due to their rapid and large negative impacts that may lead to failure in the entire dynamic system. Numerous studies have been carried out to counter or reject their effects while ensuring stability in the dynamic system. One promising method is to use an ADRC strategy such as the work done in [172] where the study proposed a robust tracking control unit based on the ADRC and flatness theory with ESO to improve the tracking performance of a quadcopter model. The results showed the efficiency of the proposed control strategy in rejecting the external disturbances and uncertainties. Najm and Ibraheem [173] also presented an improved approach of ADRC consisting of an improved tracking differentiator (ITD), a LESO, and a non-linear PID controller (NLPID) to stabilize a multicopter model and efficiently expel the exogenous disturbances and uncertainties. The superiority of the proposed control structure was clearly demonstrated when compared to the conventional PID. Further, Zhang *et al.* [174] displayed a sliding mode ADRC scheme to improve tracking control of a quadcopter system with an efficient disturbance rejection capability. The proposed control strategy performed excellently in comparison to the classical ADRC.

One of the innovative methods to control the dynamical systems is the active force control (AFC) technique that was first demonstrated by Hewit and Burdess [175]. It can be

readily integrated with the classical, modern, or intelligent controllers to effectively trigger its robust control action. The basic idea of the AFC technique is the appropriate estimation of the mass/inertia parameter of the dynamical system and measurements of the acceleration and force/torque signals generated by the system as shown in **Figure 13**. Some research works have been reported in [176], [177] that analytically utilized the AFC-based technique with a PID controller to control the TRMS model and compensate for the applied disturbances. The works presented a comparative study of system performance by analyzing the output responses based on PID-AFC, PID-AFC-ANN, and PID-AFC-FL schemes. It was concluded that the PID-AFC-FL is deemed more robust and effective in trajectory tracking and significantly improved the attitude control with a much faster response when compared to the other schemes. However, the efficiency of the AFC technique was not validated experimentally.

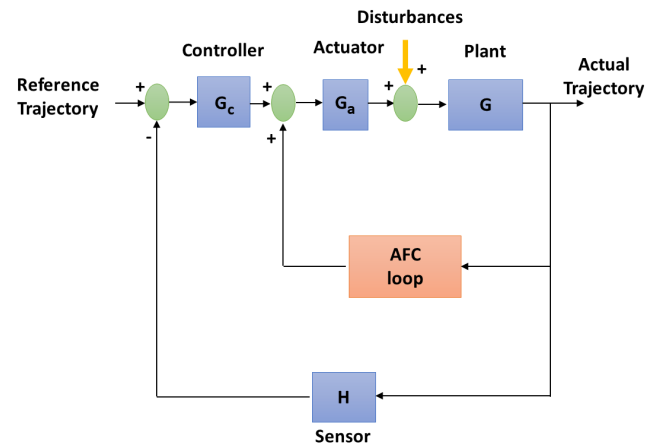

FIGURE 13. The schematic diagram of the AFC technique.

Similarly, Omar *et al.* [69] applied the AFC method to a quadcopter model that was adjusted using the crude approximation method with a PID controller tuned using TEM to control the altitude and yaw motions subjected to various types of external disturbances. It was shown that the PID-AFC strategy significantly improved the altitude control with a much faster response than the conventional PID controller. Additionally, Abdelmaksoud *et al.* [178] presented an innovative hybrid control scheme for a quadrotor model to improve the disturbances rejection capability and body jerk performance by utilizing the AFC-based robust intelligent control system via a simulation study. However, based on the literature, no research work has been performed related to the practical implementation of the intelligent active force control (IAFC) strategy on the UAV systems to assess its viability in enhancing disturbance rejection capability and its agreement with the simulation results counterpart.

2) SLUNG LOAD MOTION SUPPRESSION

One of the vital issues, that has recently attracted researchers is the slung load or load swing motion and the ability of the control system to stabilize the rotorcraft system by suppressing the slung load vibrations and oscillations to reach the desired location. Kuszniir and Smoczek [179], proposed a

control method combining a FBL strategy to control the attitude and altitude dynamics with an adaptive pole placement method-based SMC to suppress horizontal positioning and payload vibrations for a coupled quadcopter-pendulum system. The results showed the efficacy of the suggested control scheme in minimizing the vibrational levels compared to the partial FBL controller and zero vibration derivative-derivative (ZVDD) input shaper. Yu *et al.* [180] implemented a non-linear BC for an underactuated quadcopter- slung load system with the simulated results revealed the effectiveness and robustness of the proposed strategy while experimental results showed the validity and capability of the scheme in damping the oscillations. In another work, Xian *et al.* [181] presented a non-linear adaptive controller based on energy analysis of a quadcopter slung-payload system in the presence of unknown system parameters and aerodynamic drag force. The experimental results demonstrated superior system performance and robustness in achieving good position control and suppressing the payload swing motion quickly and effectively. De Angelis *et al.* [182] also suggested a novel control strategy based on an artificial two-time-scale separation of system dynamic modes to stabilize a multirotor holding a suspended load. The simulated results showed the suitability of the proposed strategy for practical application in various operational scenarios. Shi *et al.* [183] presented a harmonic extended state observer (HESO)-based anti-swing attitude control method for a quadcopter both numerically and experimentally and the system is subjected to a slung load effect. The results showed better performance and robustness of the proposed approach when compared to the traditional second-order ESO in estimating the periodic disturbances. Further, Liang *et al.* [184] proposed a time-optimal motion planning method for a multirotor system to improve the reference tracking and suppress the vibrational level of a payload swing motion. The experimental results implied the superior performance of the proposed method to effectively suppress and dampen the vibrations. Guerrero-Sánchez *et al.* [185] also applied both analytically and experimentally, a control technique to achieve package transportation quickly and safely while at the same time, solve the load fluctuation stability problems by equipping a quadcopter model with an interconnection and damping assignment-passivity based control strategy. The results showed the effectiveness of the suggested technique in improving the trajectory tracking capability, stabilizing the dynamic system, rejecting parametric uncertainties, and reducing the fluctuation motion.

3) NON-TRIVIAL MANEUVERS CONTROL

For the non-trivial maneuvers, Bhargavapuri *et al.* [186] proposed a practical, nominal, and robust non-linear BC systems for a variable-pitch quadcopter in which the results showed the effectiveness of the proposed controller in enhancing the attitude and position tracking, and flip maneuver as well. Meanwhile, Liu *et al.* [187] developed a fully robust non-linear control strategy consisting of an attitude controller, BC strategy, six-dimensional observer, and an on-line

trajectory planner based on a MPC approach for a multirotor model subjected to external disturbances and uncertainties to achieve stability, improve complex trajectory tracking, and perform forceful maneuvers. Experimental results demonstrated the superiority of the suggested strategy under the influence of strong winds, co-ordinated navigation, and navigation with obstacles.

4) COLLISION AVOIDANCE

Due to the absence of the pilot on board, safe flying is a major concern for UAVs. Reducing the collision rates/tendencies and avoiding obstacles with rapid and predictive responses are indispensable for preventing any collisions. Various research works have been conducted to enhance the collision avoidance control and efficiently improve responses for any known or unknown obstacles. Dai *et al.* [188] introduced an automatic obstacle avoidance system based on a convolutional neural network (CNN) for a quadcopter system to automatically avoid obstacles and fly safely and efficiently in unknown indoor/outdoor environments. The method revealed several advantages including low sensor requirements, strong learning capability, light-weight network structure, and environmental adaptability. Huang *et al.* [189] also proposed a finite-time formation tracking control with complicated collision avoidance based on the artificial potential function (APF) and fast terminal sliding mode surface (FTSM) for a group of quadcopter UAVs subjected to external disturbances. The results showed the ability of the proposed strategy to track the desired trajectory in a specific formation arrangement within the safe distance while simultaneously avoid moving obstacles. Arul and Manocha [190] developed a novel decentralized collision avoidance algorithm based on optimal reciprocal collision avoidance (ORCA) and flatness-based MPC to navigate a group of quadcopters subjected to fixed and moving obstacles. It was shown the proposed control strategy performed excellently in terms of smoothness in trajectory tracking and lower collision rates during severe maneuvering compared to the other state-of-the-art decentralized methods. Abdul Samed *et al.* [191] investigated the design of a novel robust control structure consisting of adaptive fuzzy controllers and tunable PID controllers (TPIDCs) both adjusted using the PSO algorithm for a quadcopter model operated in an unknown environment. The results showed the ability of the proposed control system in maintaining the desired trajectory tracking with obstacle avoidance capability. Yang *et al.* [192] proposed a new reactive obstacle avoidance system that employed an on-line adaptive convolutional neural networks and traversable way-point selection with consideration of non-uniformly distributed depth errors and field of view constraint to improve depth estimation from a monocular camera in unfamiliar environments for a quadcopter aircraft. Best results were achieved compared with state-of-the-art methods plus it also demonstrated the effectiveness of the proposed system for real-time applications.

For hexacopter systems, Park and Cho [193] suggested a reactive 3D maneuver strategy based on a collision avoidance

algorithm enhanced using the collision cone approach to avoid potential collisions. The simulation results showed the effectiveness of the proposed strategy in satisfactory handling the moving obstacles. Chen *et al.* [194] also conducted numerically and experimentally, a monocular vision-based algorithm to detect obstacles and identify obstacle-free regions for efficiently guiding a multicopter platform. It was concluded that the proposed strategy produced satisfactory results in detecting obstacles and estimating depth in unknown outdoor environments.

5) FAULT-TOLERANT CONTROL

Fault detection or fault-tolerant control is essential for UAVs. This is because a slight fault, damage, or failure in any component of the aerial system may lead to catastrophic consequences. Several studies have been proposed to provide quick and comprehensive solutions related to fault-tolerant control. Emami and Banazadeh [195] proposed a novel fault-tolerant MPC-based trajectory tracking approach for a multirotor system. A generalized online sequential extreme learning machine (OS-ELM) was presented to identify the corresponding coefficients of the actuator faults. Both the simulation and experimental results demonstrated the efficiency of the suggested control system to ensure stability and provide satisfactory performance in trajectory tracking in a 3D environment with actuator faults and external disturbances. Wang *et al.* [196] introduced systematically and experimentally, an active fault-tolerant control strategy based on adaptive SMC and recurrent NN for a quadcopter platform subjected to uncertainties and actuator faults. The results indicated the ability of the proposed strategy to maintain tracking performance and stability and its superiority compared to the model-based fault estimator and conventional adaptive SMC. Mallavalli and Fekih [197] presented an adaptive fuzzy state observer-based integral terminal SMC (AFSE-ITSMC) scheme to solve the trajectory tracking problem for a quadcopter system subjected to simultaneous actuator faults, exogenous disturbances, and actuator saturation limits. The results showed the efficacy and robustness of the proposed strategy in improving tracking performance without any performance degradation even under worst-case scenarios. Further, Nian *et al.* [198] developed both an adaptive fault estimation observer (AFEO) and dynamic output feedback fault-tolerant controller (DOFFTC) using the interval matrix method and H_∞ method to solve the problem of fault estimation and fault-tolerant control for a multirotor model in the presence of external disturbances and parameter uncertainties. The robustness and durability of the planned strategy were shown in improving the reference tracking capability and AFEO was found to have faster estimation speed and estimation accuracy. Falconi *et al.* [199] presented, numerically and practically, an adaptive fault-tolerant controller to control position tracking of a hexacopter model. The results revealed the efficacy of the proposed strategy in dealing with any unknown degradation and failure of any rotor.

6) TIME-VARYING NATURE OF THE ENVIRONMENT

The time-varying nature of the environment can affect the control strategies. An end-to-end survey was presented on available air to ground (AG) propagation channel measurement campaigns, large- and small-scale fading channel models, limitations, and future research directions for UAV communication scenarios [200]. Rieth *et al.* [201] concentrated on aircraft to ground station channel sounding and characterization for UAV control and non-payload communication (CNPC) link designs to avoid any degradation in the performance and reliability of the wireless communication system. Furthermore, She *et al.* [202] established a framework of maximizing the available range of the ground control station for ultra-reliable and low-latency communications in the CNPC links of the UAV communication systems via optimizing the altitude of UAVs, durations of uplink and downlink phases, and the antenna configuration. The results showed the ability of modified distributed multi-antenna systems (M-DAS) in remarkably improving the maximal available range of the ground control station, compared to distributed multi-antenna systems (DAS) and centralized multi-antenna systems (CAS). While Harikumar *et al.* [203] proposed an oxyrrhis marina-inspired search and dynamic formation control (OMS-DFC) structure for multi UAV systems to effectively search and neutralize of dynamic targets (forest fire) in unknown or uncertain environments. Moreover, In the work done by [204], novel equalization methods were synthesized for continuous phase modulated (CPM) signals to be used in UAV CNPC links operating over doubly selective wireless channels. The obtained results revealed that the proposed receiver structures are able to satisfactorily compensate for dual-selective channels and provide good performances even for low-to-moderate values of energy contrast in typical UAV scenarios.

E. DISCUSSION, SCIENTIFIC REFLECTIONS, AND FUTURE DIRECTIONS

From the preceding discussion of the various control strategies of the rotorcraft systems, it can be deduced that the linear control systems are characterized by their ability to ensure the stability of closed-loop dynamic systems within small zones around the operating points, less energy consumption, low cost, ease in designing, implementing, tracking and solving various problems. However, they do not have the ability to cover all the operating and loading conditions and are also not robust enough against the different types of external disturbances and uncertainties. While non-linear controllers have a wider operating range, better durability with faster responses, and greater efficacy against external disturbances and uncertainties, they are nevertheless usually costly, complex, and more sensitive to parametric changes and may have detrimental effects on the system's transient responses such as chattering and noise which in turn may lead to potential failure in some dynamic systems.

Regarding performance analysis and evaluation of the latest technology applied to UAVs and rotorcraft systems, the appropriate choice of a specific control technique depends on the control target the aerial vehicle must meet, target mission, and test rig developed for testing to be configured for implementation in real-time applications. Most of the proposed control strategies provide good performance under normal conditions but differ in performance under different operating and loading conditions. Also, the accuracy of the mathematical model is a necessity to regulate performance but in the case of complex mathematical modeling, model-free based control is a smart solution. Moreover, tuning the proposed control system is vital because it improves the control action of the controller and thus enhances the system performance. There are numerous optimizing and intelligent methods used for tuning but to choose the best method, it depends on the properties of the controller, characteristics of the dynamic system, and ease of implementation in simulation and experimentation environments. One of the best options is perhaps the ILC or FL due to their ease of implementation and ability to optimize the control parameters on-line and automatically; this is particularly essential for autonomous systems. In terms of experimental implementation for both indoor and outdoor environments, the minimal logistics and infrastructure surrounding the hardware and software aspects should be adequately prepared. This may involve flexible computing interfaces using the universal serial bus (USB) or serial peripheral interface (SPI) connections that are configured to be fully compatible with the popular MATLAB/Simulink or LabVIEW computing platforms and Intel Aero Compute Board or QFLEX 2 computing interface. The outdoor environment, in particular, may include real-life cases, readily available autopilots such as Pixhawk that is compatible with remote control (RC) transmitter and receiver [205], [206].

Based on previous studies, the percentages related to the extent of the use of various control strategies for the categories involving twin-rotor, quad-rotor, and multi-rotor models using pie charts based on the *Web of Science* and *Scopus* databases over the last five years are graphically shown in Figures 14 to 16.

It can be concluded that the PID controller is one of the most designed and commonly used control types in research works related to rotorcraft systems control, either separately, in conjunction with other control systems, or for comparison with the proposed new control systems to test their effectiveness.

The FOPID controller has revealed efficacy against disturbances and uncertainties and can be combined with non-linear or intelligent control systems to add more robustness and effectiveness.

Arguably, the H_∞ controller is the least common type of linear control and some research works have combined it with other control strategies to add robustness in rejecting model uncertainties and external disturbances and improve reference tracking.

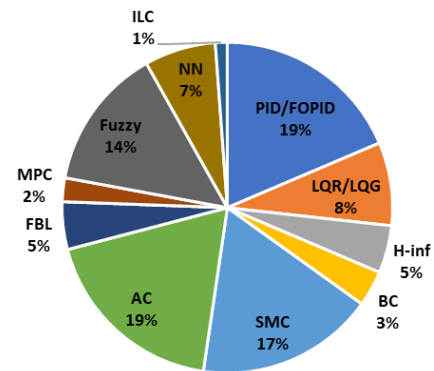

FIGURE 14. Distribution of various control strategies for twin-rotor systems.

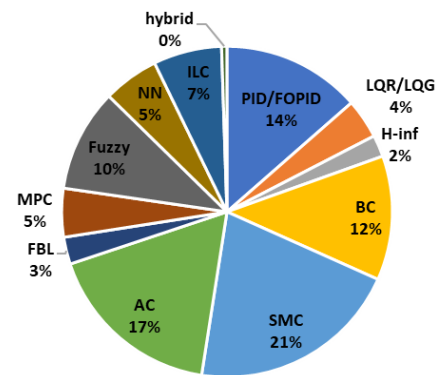

FIGURE 15. Distribution of various control strategies for quad-rotor systems.

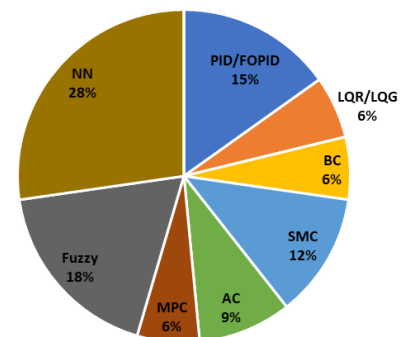

FIGURE 16. Distribution of various control strategies for multi-rotor systems.

It can also be noted that the most commonly non-linear controllers used are SMC and adaptive controllers due to their efficiency and durability and with regard to the chattering effect (for SMC, in particular), this study has demonstrated a number of powerful solutions to reduce this phenomenon.

Intelligent control systems show distinct positive performance, especially when used together or combined with linear or non-linear controllers or when applied to adjust the control parameters as they further consolidate the strength, robustness, efficiency of the proposed control schemes allowing the dynamic system to operate in varied operating and loading conditions.

The Neuro-fuzzy system is a distinctive hybrid system that combines the adaptive learning capabilities from NNs and the

ability of FL rules in which the results observed better performance in handling noise and external disturbances. However, it may give an unsatisfactory performance in dealing with uncertainties and parameter changes. Thus, an evolving intelligent system (EIS)-based fuzzy system is a proper solution to cope up with severe challenges and changes.

Meanwhile, hexacopter, octocopter, etc. still need more attention and scrutiny. Further research works on them, either experimentally and analytically should be carried out, as they are promising systems due to their durability, overactuation, and strength. However, problems related to their energy sources still present a dilemma for these systems.

AFC technique is a promising method that can be seamlessly merged with classical, modern, or intelligent controllers to stabilize the dynamic system and effectively reject the different types of unknown/known external disturbances and uncertainties. Besides, its control algorithm is simple, implying potential excellent real-time implementation.

A complete summary of the advantages and shortcomings of the various control strategies discussed for the rotorcraft UAVs is shown in **Table 3**.

With regard to future directions and latest technology relating to multicopter systems, one such example can be found in Beg *et al.* [207] in which they introduced and implemented an intelligent and autonomous traffic policing system that has the ability to detect traffic emergency cases or investigative situations with quick action units using UAV networks to solve deficiencies in traffic policing and emergency response handling systems involving many critical scenarios. Furthermore, the new system has the ability to issue emergency response units in case of severe/extreme scenarios to significantly reduce time delay and provide route prioritization service. Additionally, the proposed system can assist to track stolen vehicles or reroute traffic effectively in the event of an emergency.

Based on the study, a number of research problems need more attention and have to be taken into account when designing and developing the control schemes for UAVs as follows:

- 1- In aggressive maneuvering, for instance, the singularities that exist in a vertical looping maneuver have to be avoided; real-time implementation of how effective of a maneuver regulation-based control scheme on real rotorcraft UAV models, and path planning algorithms design need to take into account the aerodynamic and friction effects to allow aggressive aerobatic trajectories.
- 2- Smooth take-off and landing under complex situations such as inclined levels, curved surfaces, and horizontal and flat pads with to selectively adopt a disturbance rejection capability along with fault detection and recovery algorithm to improve flight safety and anti-windup scheme.
- 3- Finite-time controller design based on disturbance-observer with atmosphere disturbances and multiple time-varying delays.

TABLE 3. Advantages and shortcomings of various control strategies for UAVs.

Control Approach	Advantages	Shortcomings
PID	<ul style="list-style-type: none"> • Less energy consumption • Simple in design • Common in industry 	<ul style="list-style-type: none"> • Limited operating range • Unsuccessful in compensating for the various types of disturbances • Inability in performing aggressive maneuvers • Not robust • Not effective for complex systems
LQR/LQG	<ul style="list-style-type: none"> • No need for complete information about the state • Appropriate tracking ability 	<ul style="list-style-type: none"> • High level of mathematical understanding • Not the best option for highly non-linear systems
H_{∞}	<ul style="list-style-type: none"> • Accurate tracking ability • Successful in rejecting disturbances and uncertainties 	<ul style="list-style-type: none"> • Large control signals • Complete knowledge of the full state
Backstepping Control (BC)	<ul style="list-style-type: none"> • Robust • Fast Response • Less computational resources • Successful in rejecting disturbances • Precise tracking capability 	<ul style="list-style-type: none"> • Loss of performance in the event of vigorous disturbances and uncertainties • Chattering effect
Sliding Mode Control (SMC)	<ul style="list-style-type: none"> • Robust • Simple structure • Accurate tracking capability • Disturbance rejection capability • Insensitive to the external environment changes 	<ul style="list-style-type: none"> • Large energy consumption
Feedback Linearization (FBL)	<ul style="list-style-type: none"> • Smooth control signal • Simple design and good performance • Compensate for blade flapping • Aggressive maneuvers 	<ul style="list-style-type: none"> • Extreme sensitive to parameters change • Loss of precision • Prior knowledge of model
Adaptive	<ul style="list-style-type: none"> • Robust • Insensitive to parameters and external environment changes • Stability guarantee • Successful in rejecting disturbances and uncertainties • Superior in the desired tracking 	<ul style="list-style-type: none"> • High cost. • Practical implementation • Based on adaptation to the plant uncertainties • Chattering effect
Model Predictive Control (MPC)	<ul style="list-style-type: none"> • Disturbances rejection capability • Fast reference tracking • Allowing dynamic difficulties • Insensitive to parameters change and sensors failure 	<ul style="list-style-type: none"> • Accurate dynamic model • High computational cost. • Not guaranteed stability
Intelligent	<ul style="list-style-type: none"> • Wide operating range • Model-free design 	<ul style="list-style-type: none"> • Abundant computational resources • Need expert knowledge for a good initialization

- 4- Non-linear stochastic dynamics with non-affine controls for troublesome environments.
- 5- Swing-motion attenuation with different types of cables suspending various forms of payloads in the presence of external disturbances and model uncertainties within various operating conditions.
- 6- Beyond velocity and acceleration, how effective the control strategies can handle the jerk, snap, and higher derivatives, and optimal trajectory generation for rotorcraft systems.
- 7- Real-time implementation of the AFC-based controller for real rotorcraft systems. This will be extremely useful to further evaluate the practical viability of the method in real-world scenarios, considering different operating and loading conditions.
- 8- Slung load motion suppression for other multirotor systems such as hexacopter, octocopter, etc.

IV. OTHER RELATED DEVELOPMENTS

There is no doubt that the rapid development in smart and composite materials, control theory, nano/micro-controller platforms, electronic technologies, DC motors, 3D printers, etc., has caused a quantum/huge leap in the development of the UAVs industry in general and rotorcraft systems, in particular. This UAVs development not only attracted the academia circle but also industrialists and amateurs.

Regarding the recent developments of the twin-rotor helicopter, the *Quanser* company designed a fully integrated dual-motor laboratory experimental module for advanced control research and for teaching control concepts, called *Quanser AERO*, as shown in **Figure 17**. It is a compact and integrated system that includes highly efficient coreless DC motors, flexible *QFLEX 2* computing interface for *USB* and *SPI* connections, integrated data acquisition (DAQ) device, built-in voltage amplifier with integrated current sensor, digital tachometer, and high-resolution optical encoder. It is a reconfigurable system, from 1-DOF and 2-DOF helicopter to a half-quadcopter [205]. Also, *ACROME* company provides an integrated system of a 1-DOF model called *ACROME 1 DOF Copter* for control fundamentals and advanced research, as shown in **Figure 18**. It features a solid body, high-resolution incremental encoder, fully open-source software, and is fully compatible with *MATLAB/Simulink* and *LabVIEW* environments [208].

There are several multicopters developed for commercial and research uses (indoors and outdoors environments), and development is still on-going.

For the commercial market, many types can be found, based on a number of factors, like flight endurance, camera resolution, range, battery life, etc. To name a few, some of the top professional multirotor models with long battery life, an HD camera, and simple controls, are *DJI Phantom 4 Pro*, *DJI Inspire 2*, *DJI Mavic 2 Pro*, *Kespry 2S*, *Yuneec Typhoon H*, *DJI Matrice 200*, *Parrot AR.Drone 2*, *ELIOS 1 and 2*, *Parrot ANAFI USA*, *Trimble ZX5*, and *Yuneec 3DR* [17], [209]–[211].

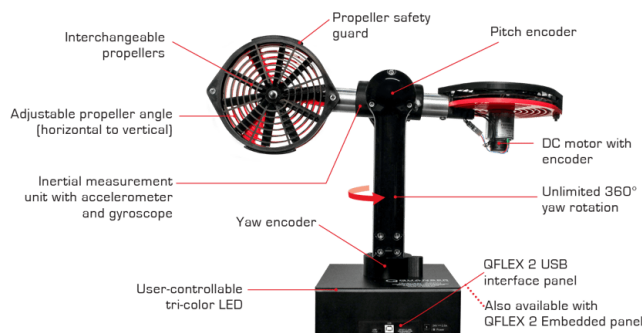

FIGURE 17. Quanser aero platform.



FIGURE 18. ACROME 1 DOF copter.

For research use, *QDrone* from *Quanser* company is a high-performance quadcopter monitoring device. It is suitable for a wide range of research applications and is able to test new control strategies due to its several desirable features, such as light weight, high maneuverability, and little downtime for maintenance [212]. It is equipped with avionics data acquisition, 3-axis accelerometer, 3-axis gyroscope, sonar height sensor, and high-resolution cameras. It is an innovative indoor platform, as shown in **Figure 19**, for accurate localization and tracking system, and real-time decision making [205].

It has been observed that the rotorcraft UAVs have undergone impressive evaluation and development in the past few years. Meanwhile, researchers continue to test new designs, configurations, and control strategies for realistic implementation environments. Rotorcraft will continue to evolve to become safer, faster, smaller, stronger, and smarter.



FIGURE 19. QDrone platform.

V. CONCLUSION

Recently, and due to their flexibility and versatility, the rotorcraft or rotary-wing UAVs are becoming extremely popular in both civil and military sectors. However, there are several and critical challenges deemed to occur during the flight or while performing specific tasks that need to be countered and resolved. Some of these challenges include external disturbances, model uncertainties, and unknown obstacles. Also, these types of vehicles are considered highly non-linear, coupled, and complex systems. Therefore, it is imperative to develop effective and robust control strategies for controlling these dynamical systems. Researchers have recently given more attention to rotorcraft UAVs and a large number of research works have been conducted because of their benefits and diversity in terms of applications. In this paper, a state-of-the-art review of various control strategies for rotorcraft systems in the presence of various impediments or adverse operating/loading conditions has been highlighted. Also, the detailed mathematical dynamic models for both the twin-rotor helicopter and quadcopter have been derived as case studies since they are considered the most utilized rotorcraft UAVs, considering certain assumptions and considerations. This study has also demonstrated the innovative and novel control techniques that can be implemented for countering some of these impediments that affect the performance of the aerial vehicles. In addition, some of the related off-the-shelf developments in the rotorcraft systems for the research and commercial uses have been considered.

REFERENCES

- [1] A. S. Saeed, A. B. Younes, C. Cai, and G. Cai, "A survey of hybrid unmanned aerial vehicles," *Prog. Aerosp. Sci.*, vol. 98, pp. 91–105, Apr. 2018, doi: [10.1016/j.paerosci.2018.03.007](https://doi.org/10.1016/j.paerosci.2018.03.007).
- [2] S. Narayanan, E. Chaniotakis, and C. Antoniou, "Shared autonomous vehicle services: A comprehensive review," *Transp. Res. C, Emerg. Technol.*, vol. 111, pp. 255–293, Feb. 2020, doi: [10.1016/j.trc.2019.12.008](https://doi.org/10.1016/j.trc.2019.12.008).
- [3] S. Islam, R. Ashour, and A. Sunda-Meya, "Haptic and virtual reality based shared control for MAV," *IEEE Trans. Aerosp. Electron. Syst.*, vol. 55, no. 5, pp. 2337–2346, Oct. 2019, doi: [10.1109/TAES.2018.2885642](https://doi.org/10.1109/TAES.2018.2885642).
- [4] S. Islam, P. X. Liu, A. E. Saddik, R. Ashour, J. Dias, and L. D. Seneviratne, "Artificial and virtual impedance interaction force reflection-based bilateral shared control for miniature unmanned aerial vehicle," *IEEE Trans. Ind. Electron.*, vol. 66, no. 1, pp. 329–337, Jan. 2019, doi: [10.1109/TIE.2018.2793178](https://doi.org/10.1109/TIE.2018.2793178).
- [5] S. Javdani, S. S. Srinivasa, and J. A. Bagnell, "Shared autonomy via hindsight optimization," Apr. 2015, *arXiv:1503.07619*. Accessed: Jul. 18, 2020. [Online]. Available: <http://arxiv.org/abs/1503.07619>
- [6] A. J. Keane, A. Söbester, and J. P. Scanlan, *Small Unmanned Fixed-Wing Aircraft Design: A Practical Approach*. Hoboken, NJ, USA: Wiley, 2017.
- [7] M. Schilling, S. Kopp, S. Wachsmuth, B. Wrede, H. Ritter, T. Brox, B. Nebel, and W. Burgard, "Towards a multidimensional perspective on shared autonomy," in *Proc. AAAI Fall Symp. Ser.*, 2016, pp. 1–7.
- [8] N. R. Council, *Autonomous Vehicles in Support of Naval Operations*. Washington, DC, USA: National Academies Press, 2005.
- [9] P. Fahlstrom and T. Gleason, *Introduction to UAV Systems*. Hoboken, NJ, USA: Wiley, 2012.
- [10] H. Shakhtrah, A. H. Sawalmeh, A. Al-Fuqaha, Z. Dou, E. Almaita, I. Khalil, N. S. Othman, A. Khreishah, and M. Guizani, "Unmanned aerial vehicles (UAVs): A survey on civil applications and key research challenges," *IEEE Access*, vol. 7, pp. 48572–48634, 2019, doi: [10.1109/ACCESS.2019.2909530](https://doi.org/10.1109/ACCESS.2019.2909530).
- [11] O. I. D. Bashi, W. Z. W. Hasan, N. Azis, S. Shafie, and H. Wagatsuma, "Autonomous quadcopter altitude for measuring risky gases in hazard area," *J. Telecommun., Electron. Comput. Eng.*, vol. 10, nos. 2–5, pp. 31–34, Jul. 2018.
- [12] H. T. Berie and I. Burud, "Application of unmanned aerial vehicles in earth resources monitoring: Focus on evaluating potentials for forest monitoring in Ethiopia," *Eur. J. Remote Sens.*, vol. 51, no. 1, pp. 326–335, Jan. 2018, doi: [10.1080/22797254.2018.1432993](https://doi.org/10.1080/22797254.2018.1432993).
- [13] M. M. Ferdous, S. G. Anavatti, M. Pratama, and M. A. Garratt, "Towards the use of fuzzy logic systems in rotary wing unmanned aerial vehicle: A review," *Artif. Intell. Rev.*, vol. 53, no. 1, pp. 257–290, Jan. 2020, doi: [10.1007/s10462-018-9653-z](https://doi.org/10.1007/s10462-018-9653-z).
- [14] L. R. G. Carrillo, A. E. D. López, R. Lozano, and C. Pégard, *Quad Rotorcraft Control: Vision-Based Hovering and Navigation*. London, U.K.: Springer, 2013.
- [15] S. N. Ghazbi, Y. Aghli, M. Alimohammadi, and A. A. Akbari, "Quadrotors unmanned aerial vehicles: A review," *Int. J. Smart Sens. Intell. Syst.*, vol. 9, no. 1, pp. 309–333, Mar. 2016, doi: [10.21307/ijssis-2017-872](https://doi.org/10.21307/ijssis-2017-872).
- [16] A. S. Saeed, A. B. Younes, S. Islam, J. Dias, L. Seneviratne, and G. Cai, "A review on the platform design, dynamic modeling and control of hybrid UAVs," in *Proc. Int. Conf. Unmanned Aircr. Syst. (ICUAS)*, Jun. 2015, pp. 806–815, doi: [10.1109/ICUAS.2015.7152365](https://doi.org/10.1109/ICUAS.2015.7152365).
- [17] C. F. Liew, D. DeLatte, N. Takeishi, and T. Yairi, "Recent developments in aerial robotics: A survey and prototypes overview," Nov. 2017, *arXiv:1711.10085*. Accessed: Dec. 5, 2018. [Online]. Available: <http://arxiv.org/abs/1711.10085>
- [18] S. Barbarino, O. Bilgen, R. M. Ajaj, M. I. Friswell, and D. J. Inman, "A review of morphing aircraft," *J. Intell. Mater. Syst. Struct.*, vol. 22, no. 9, pp. 823–877, Jun. 2011, doi: [10.1177/1045389X11414084](https://doi.org/10.1177/1045389X11414084).
- [19] A. Alkamachi and E. Erçelebi, "Modelling and genetic algorithm based-PID control of H-shaped racing quadcopter," *Arabian J. Sci. Eng.*, vol. 42, no. 7, pp. 2777–2786, Jul. 2017, doi: [10.1007/s13369-017-2433-2](https://doi.org/10.1007/s13369-017-2433-2).
- [20] M. J. G. Guarnizo, R. C. L. Trujillo, and M. J. A. Guacaneme, "Modeling and control of a two DOF helicopter using a robust control design based on DK iteration," in *Proc. 36th Annu. Conf. IEEE Ind. Electron. Soc. (IECON)*, Nov. 2010, pp. 162–167, doi: [10.1109/IECON.2010.5675183](https://doi.org/10.1109/IECON.2010.5675183).
- [21] Y. Xin, Z.-C. Qin, and J.-Q. Sun, "Input-output tracking control of a 2-DOF laboratory helicopter with improved algebraic differential estimation," *Mech. Syst. Signal Process.*, vol. 116, pp. 843–857, Feb. 2019, doi: [10.1016/j.ymssp.2018.07.027](https://doi.org/10.1016/j.ymssp.2018.07.027).
- [22] F. S. dos Barbosa, G. G. Neto, and A. elico, "Digital integrative LQR control of a 2DOF helicopter," presented at the 21st Congresso Brasileiro de Automática, Vitória, Brazil, Oct. 2016.
- [23] K. Harshatha, P. S. Manoharan, and M. Varatharajan, "Model predictive control of TRMS," in *Proc. Biennial Int. Conf. Power Energy Syst., Towards Sustain. Energy (PESTSE)*, Jan. 2016, pp. 1–5, doi: [10.1109/PESTSE.2016.7516455](https://doi.org/10.1109/PESTSE.2016.7516455).
- [24] Z.-C. Qin, Y. Xin, and J.-Q. Sun, "Dual-loop robust attitude control for an aerodynamic system with unknown dynamic model: Algorithm and experimental validation," *IEEE Access*, vol. 8, pp. 36582–36594, 2020, doi: [10.1109/ACCESS.2020.2974578](https://doi.org/10.1109/ACCESS.2020.2974578).
- [25] S. P. Sadala and B. M. Patre, "A new continuous sliding mode control approach with actuator saturation for control of 2-DOF helicopter system," *ISA Trans.*, vol. 74, pp. 165–174, Mar. 2018, doi: [10.1016/j.isatra.2018.01.027](https://doi.org/10.1016/j.isatra.2018.01.027).
- [26] B. J. Emran and H. Najjaran, "A review of quadrotor: An underactuated mechanical system," *Annu. Rev. Control*, vol. 46, pp. 165–180, Jan. 2018, doi: [10.1016/j.arcontrol.2018.10.009](https://doi.org/10.1016/j.arcontrol.2018.10.009).
- [27] X. Ding, X. Wang, Y. Yu, and C. Zha, "Dynamics modeling and trajectory tracking control of a quadrotor unmanned aerial vehicle," *J. Dyn. Syst., Meas., Control*, vol. 139, no. 2, p. 11, Feb. 2017.
- [28] V. Praveen and A. S. Pillai, "Modeling and simulation of quadcopter using PID controller," *Int. J. Control Theory Appl.*, vol. 9, no. 15, pp. 7151–7158, Jan. 2016.
- [29] S.-E.-I. Hasseni and L. Abdou, "Decentralized PID control by using GA optimization applied to a quadrotor," *J. Autom., Mobile Robot. Intell. Syst.*, vol. 12, no. 2, pp. 33–44, Jun. 2018, doi: [10.14313/JAMRIS_2-2018/9](https://doi.org/10.14313/JAMRIS_2-2018/9).
- [30] H. Elkholy, "Dynamic modeling and control of a quad rotor using linear and nonlinear approaches," M.S. thesis, Amer. Univ. Cairo, Cairo, Egypt, 2014. [Online]. Available: <http://dar.aucegypt.edu/handle/10526/3965>

- [31] A. M. Abdallah, "Flight dynamics nonlinearity assessment across a new aerodynamic attitude flight envelope," Ph.D. dissertation, Aersp. Eng., Old Dominion Univ., Norfolk, VA, USA, 2015. [Online]. Available: https://digitalcommons.odu.edu/mae_etds/107, doi: [10.25777/hakk-hy29](https://doi.org/10.25777/hakk-hy29).
- [32] N. A. Ofodile and M. C. Turner, "Anti-windup design for input-coupled double integrator systems with application to quadrotor UAV's," *Eur. J. Control*, vol. 38, pp. 22–31, Nov. 2017, doi: [10.1016/j.ejcon.2017.07.002](https://doi.org/10.1016/j.ejcon.2017.07.002).
- [33] N. S. Özbek, M. Önkol, and M. Ö. Efe, "Feedback control strategies for quadrotor-type aerial robots: A survey," *Trans. Inst. Meas. Control*, vol. 38, no. 5, pp. 529–554, May 2016, doi: [10.1177/0142331215608427](https://doi.org/10.1177/0142331215608427).
- [34] A. Zulu and S. John, "A review of control algorithms for autonomous quadrotors," *Open J. Appl. Sci.*, vol. 4, no. 14, pp. 547–556, 2014, doi: [10.4236/ojapps.2014.414053](https://doi.org/10.4236/ojapps.2014.414053).
- [35] R. Maiti, K. D. Sharma, and G. Sarkar, "PSO based parameter estimation and PID controller tuning for 2-DOF nonlinear twin rotor MIMO system," *Int. J. Autom. Control*, vol. 12, no. 4, pp. 582–609, Jan. 2018, doi: [10.1504/IJAAC.2018.095109](https://doi.org/10.1504/IJAAC.2018.095109).
- [36] S. K. Pandey, J. Dey, and S. Banerjee, "Design of robust proportional-integral-derivative controller for generalized decoupled twin rotor multi-input-multi-output system with actuator non-linearity," *Proc. Inst. Mech. Eng., I, J. Syst. Control Eng.*, vol. 232, no. 8, pp. 971–982, Aug. 2018, doi: [10.1177/0959651818771487](https://doi.org/10.1177/0959651818771487).
- [37] R. Ayad, W. Nouibat, M. Zareb, and Y. B. Sebanne, "Full control of quadrotor aerial robot using fractional-order FOPID," *Iranian J. Sci. Technol., Trans. Electr. Eng.*, vol. 43, no. S1, pp. 349–360, Jul. 2019, doi: [10.1007/s40998-018-0155-4](https://doi.org/10.1007/s40998-018-0155-4).
- [38] O. W. Abdulwahhab and N. H. Abbas, "A new method to tune a fractional-order PID controller for a twin rotor aerodynamic system," *Arabian J. Sci. Eng.*, vol. 42, no. 12, pp. 5179–5189, Dec. 2017, doi: [10.1007/s13369-017-2629-5](https://doi.org/10.1007/s13369-017-2629-5).
- [39] A. Ates, B. B. Alagoz, and C. Yeroglu, "Master-slave stochastic optimization for model-free controller tuning," *Iranian J. Sci. Technol., Trans. Electr. Eng.*, vol. 41, no. 2, pp. 153–163, Jun. 2017, doi: [10.1007/s40998-017-0029-1](https://doi.org/10.1007/s40998-017-0029-1).
- [40] S. Ijaz, M. T. Hamayun, L. Yan, and M. F. Mumtaz, "Fractional order modeling and control of twin rotor aero dynamical system using nelder mead optimization," *J. Electr. Eng. Technol.*, vol. 11, no. 6, pp. 1863–1871, Nov. 2016.
- [41] N. Almtireen, H. Elmoaqet, and M. Ryalat, "Linearized modelling and control for a twin rotor system," *Autom. Control Comput. Sci.*, vol. 52, no. 6, pp. 539–551, Nov. 2018, doi: [10.3103/S0146411618060020](https://doi.org/10.3103/S0146411618060020).
- [42] S. K. Choudhary, "Optimal feedback control of twin rotor MIMO system with a prescribed degree of stability," *Int. J. Intell. Unmanned Syst.*, vol. 4, no. 4, pp. 226–238, Oct. 2016, doi: [10.1108/IJIUS-07-2016-0005](https://doi.org/10.1108/IJIUS-07-2016-0005).
- [43] M. Pazera, M. Buciakowski, and M. Witczak, "Robust multiple sensor fault-tolerant control for dynamic non-linear systems: Application to the aerodynamical twin-rotor system," *Int. J. Appl. Math. Comput. Sci.*, vol. 28, no. 2, pp. 297–308, Jun. 2018, doi: [10.2478/amcs-2018-0021](https://doi.org/10.2478/amcs-2018-0021).
- [44] M. Witczak, M. Buciakowski, V. Puig, D. Rotondo, and F. Nejari, "An LMI approach to robust fault estimation for a class of nonlinear systems," *Int. J. Robust Nonlinear Control*, vol. 26, no. 7, pp. 1530–1548, May 2016, doi: [10.1002/rnc.3365](https://doi.org/10.1002/rnc.3365).
- [45] J.-W. Huang, Y. Fan, Y. Xin, and Z.-C. Qin, "Demonstration of a model-free backstepping control on a 2-DOF laboratory helicopter," *Int. J. Dyn. Control*, Jun. 2020, pp. 1–12, doi: [10.1007/s40435-020-00644-9](https://doi.org/10.1007/s40435-020-00644-9).
- [46] A. Haruna, Z. Mohamed, M. Ö. Efe, and M. A. M. Basri, "Dual boundary conditional integral backstepping control of a twin rotor MIMO system," *J. Franklin Inst.*, vol. 354, no. 15, pp. 6831–6854, Oct. 2017, doi: [10.1016/j.jfranklin.2017.08.050](https://doi.org/10.1016/j.jfranklin.2017.08.050).
- [47] R. Rashad, A. Abouodonia, and A. El-Badawy, "A novel disturbance observer-based backstepping controller with command filtered compensation for a MIMO system," *J. Franklin Inst.*, vol. 353, no. 16, pp. 4039–4061, Nov. 2016, doi: [10.1016/j.jfranklin.2016.07.017](https://doi.org/10.1016/j.jfranklin.2016.07.017).
- [48] H. Rojas-Cubides, J. Cortés-Romero, H. Coral-Enriquez, and H. Rojas-Cubides, "Sliding mode control assisted by GPI observers for tracking tasks of a nonlinear multivariable twin-rotor aerodynamical system," *Control Eng. Pract.*, vol. 88, pp. 1–15, Jul. 2019, doi: [10.1016/j.conengprac.2019.04.002](https://doi.org/10.1016/j.conengprac.2019.04.002).
- [49] F. Faris, A. Moussaoui, B. Djamel, and T. Mohammed, "Design and real-time implementation of a decentralized sliding mode controller for twin rotor multi-input multi-output system," *Proc. Inst. Mech. Eng., I, J. Syst. Control Eng.*, vol. 231, no. 1, pp. 3–13, Jan. 2017, doi: [10.1177/0959651816680457](https://doi.org/10.1177/0959651816680457).
- [50] R. Rashad, A. El-Badawy, and A. Abouodonia, "Sliding mode disturbance observer-based control of a twin rotor MIMO system," *ISA Trans.*, vol. 69, pp. 166–174, Jul. 2017, doi: [10.1016/j.isatra.2017.04.013](https://doi.org/10.1016/j.isatra.2017.04.013).
- [51] S. M. Rakhtala and M. Ahmadi, "Twisting control algorithm for the yaw and pitch tracking of a twin rotor UAV," *Int. J. Autom. Control*, vol. 11, no. 2, pp. 143–163, Jan. 2017, doi: [10.1504/IJAAC.2017.083296](https://doi.org/10.1504/IJAAC.2017.083296).
- [52] A. Kulkarni and S. Purwar, "Adaptive nonlinear gain based composite nonlinear feedback controller with input saturation," *IMA J. Math. Control Inf.*, vol. 35, no. 3, pp. 757–771, Sep. 2018, doi: [10.1093/imamci/dnw075](https://doi.org/10.1093/imamci/dnw075).
- [53] G. Kavuran, A. Ates, B. B. Alagoz, and C. Yeroglu, "An experimental study on model reference adaptive control of TRMS by error-modified fractional order MIT rule," *J. Control Eng. Appl. Informat.*, vol. 19, no. 4, pp. 101–111, Dec. 2017.
- [54] R.-C. Roman, M.-B. Radac, R.-E. Precup, and E. M. Petriu, "Data-driven model-free adaptive control tuned by virtual reference feedback tuning," *Acta Polytechnica Hungarica*, vol. 13, no. 1, p. 14, 2016.
- [55] V. K. Pandey, I. Kar, and C. Mahanta, "Controller design for a class of nonlinear MIMO coupled system using multiple models and second level adaptation," *ISA Trans.*, vol. 69, pp. 256–272, Jul. 2017, doi: [10.1016/j.isatra.2017.05.005](https://doi.org/10.1016/j.isatra.2017.05.005).
- [56] N. V. Chi, "Adaptive feedback linearization control for twin rotor multiple-input multiple-output system," *Int. J. Control, Autom. Syst.*, vol. 15, no. 3, pp. 1267–1274, Jun. 2017, doi: [10.1007/s12555-015-0245-2](https://doi.org/10.1007/s12555-015-0245-2).
- [57] M. Ilyas, N. Abbas, M. UbaidUllah, W. A. Intiaz, M. A. Q. Shah, and K. Mahmood, "Control law design for twin rotor MIMO system with nonlinear control strategy," *Discrete Dyn. Nature Soc.*, vol. 2016, Jul. 2016, Art. no. 2952738, doi: [10.1155/2016/2952738](https://doi.org/10.1155/2016/2952738).
- [58] R. Raghavan and S. Thomas, "Practically implementable model predictive controller for a twin rotor multi-input multi-output system," *J. Control, Autom. Electr. Syst.*, vol. 28, no. 3, pp. 358–370, Jun. 2017, doi: [10.1007/s40313-017-0311-5](https://doi.org/10.1007/s40313-017-0311-5).
- [59] S. Arimoto, S. Kawamura, and F. Miyazaki, "Convergence, stability and robustness of learning control schemes for robot manipulators," in *Proc. Int. Symp. Robot Manipulators Recent Trends Robot., Modeling, Control Educ.*, New York, NY, USA, 1986, pp. 307–316. Accessed: May 25, 2019. [Online]. Available: <http://dl.acm.org/citation.cfm?id=23592.23632>
- [60] J.-X. Xu and Y. Tan, *Linear and Nonlinear Iterative Learning Control*. Berlin, Germany: Springer-Verlag, 2003.
- [61] R. M. Palliser, R. Costa-Castelló, and G. A. Ramos, "Iterative learning control experimental results in twin-rotor device," *Math. Problems Eng.*, vol. 2017, Oct. 2017, Art. no. 6519497, doi: [10.1155/2017/6519497](https://doi.org/10.1155/2017/6519497).
- [62] S. Behzadimanesh, A. Fatehi, and S. F. Derakhshan, "Optimal fuzzy controller based on non-monotonic Lyapunov function with a case study on laboratory helicopter," *Int. J. Syst. Sci.*, vol. 50, no. 3, pp. 652–667, Feb. 2019, doi: [10.1080/00207721.2019.1567864](https://doi.org/10.1080/00207721.2019.1567864).
- [63] R.-C. Roman, R.-E. Precup, and R.-C. David, "Second order intelligent proportional-integral fuzzy control of twin rotor aerodynamic systems," *Procedia Comput. Sci.*, vol. 139, pp. 372–380, Oct. 2018.
- [64] A. Jain, S. Sheel, and P. Kuchhal, "Fuzzy logic-based real-time control for a twin-rotor MIMO system using GA-based optimization," *World J. Eng.*, vol. 15, no. 2, pp. 192–204, Apr. 2018, doi: [10.1108/WJE-03-2017-0075](https://doi.org/10.1108/WJE-03-2017-0075).
- [65] S. Zeghlache and N. Amardjia, "Real time implementation of non linear observer-based fuzzy sliding mode controller for a twin rotor multi-input multi-output system (TRMS)," *Optik*, vol. 156, pp. 391–407, Mar. 2018, doi: [10.1016/j.ijleo.2017.11.053](https://doi.org/10.1016/j.ijleo.2017.11.053).
- [66] K. Dheeraj, J. Jacob, and M. P. Nandakumar, "Direct adaptive neural control design for a class of nonlinear multi input multi output systems," *IEEE Access*, vol. 7, pp. 15424–15435, 2019, doi: [10.1109/ACCESS.2019.2892460](https://doi.org/10.1109/ACCESS.2019.2892460).
- [67] C.-W. Lin, T.-H.-S. Li, and C.-C. Chen, "Feedback linearization and feedforward neural network control with application to twin rotor mechanism," *Trans. Inst. Meas. Control*, vol. 40, no. 2, pp. 351–362, Jan. 2018, doi: [10.1177/0142331216656758](https://doi.org/10.1177/0142331216656758).
- [68] P. Agand, M. A. Shoorehdeli, and A. Khaki-Sedigh, "Adaptive recurrent neural network with Lyapunov stability learning rules for robot dynamic terms identification," *Eng. Appl. Artif. Intell.*, vol. 65, pp. 1–11, Oct. 2017, doi: [10.1016/j.engappai.2017.07.009](https://doi.org/10.1016/j.engappai.2017.07.009).
- [69] M. Omar, M. Mailah, and S. I. Abdelmaksoud, "Robust active force control of a quadcopter," *Jurnal Mekanikal*, vol. 40, no. 2, pp. 12–22, Dec. 2017.
- [70] K. Khuwaja, N.-U.-Z. Lighari, I. C. Tarca, and R. C. Tarca, "PID controller tuning optimization with genetic algorithms for a quadcopter," *Recent Innov. Mechatron.*, vol. 5, no. 1, p. 7, Apr. 2018.

- [71] T. T. Mac, C. Copot, R. D. Keyser, and C. M. Ionescu, "The development of an autonomous navigation system with optimal control of an UAV in partly unknown indoor environment," *Mechatronics*, vol. 49, pp. 187–196, Feb. 2018, doi: [10.1016/j.mechatronics.2017.11.014](https://doi.org/10.1016/j.mechatronics.2017.11.014).
- [72] A. Noordin, M. A. M. Basri, Z. Mohamed, and A. F. Z. Abidin, "Modelling and PSO fine-tuned PID control of quadrotor UAV," *Int. J. Adv. Sci., Eng. Inf. Technol.*, vol. 7, no. 4, pp. 1367–1373, Aug. 2017, doi: [10.18517/ijaseit.7.4.3141](https://doi.org/10.18517/ijaseit.7.4.3141).
- [73] A. Adriansyah, S. H. M. Amin, A. Minarso, and E. Ihsanto, "Improvement of quadrotor performance with flight control system using particle swarm proportional-integral-derivative (PS-PID)," *Jurnal Teknologi*, vol. 79, no. 6, Aug. 2017, doi: [10.11113/jt.v79.10680](https://doi.org/10.11113/jt.v79.10680).
- [74] N. P. Putra, G. J. Maulany, F. X. Manggau, and P. Betaubun, "Attitude quadrotor control system with optimization of PID parameters based on fast genetic algorithm," *Int. J. Mech. Eng. Technol.*, vol. 10, no. 1, pp. 335–343, 2019.
- [75] S.-E.-I. Hasseni, L. Abdou, and H.-E. Glida, "Parameters tuning of a quadrotor PID controllers by using nature-inspired algorithms," *Evol. Intell.*, Nov. 2019, doi: [10.1007/s12065-019-00312-8](https://doi.org/10.1007/s12065-019-00312-8).
- [76] M. J. Mohammed, M. T. Rashid, and A. A. Ali, "Design optimal PID controller for quad rotor system," *Int. J. Comput. Appl.*, vol. 106, no. 3, pp. 0975–8887, Nov. 2014.
- [77] J. Dong and B. He, "Novel fuzzy PID-type iterative learning control for quadrotor UAV," *Sensors*, vol. 19, no. 1, p. 24, Dec. 2018, doi: [10.3390/s19010024](https://doi.org/10.3390/s19010024).
- [78] E. Kuantama, T. Vesselenyi, S. Dzitac, and R. Tarca, "PID and fuzzy-PID control model for quadcopter attitude with disturbance parameter," *Int. J. Comput., Commun. Control*, vol. 12, no. 4, pp. 519–532, Aug. 2017, doi: [10.15837/ijccc.2017.4.2962](https://doi.org/10.15837/ijccc.2017.4.2962).
- [79] D. K. Tiep and Y.-J. Ryoo, "An autonomous control of fuzzy-PD controller for quadcopter," *Int. J. Fuzzy Log. Intell. Syst.*, vol. 17, no. 2, pp. 107–113, Jun. 2017, doi: [10.5391/IJFIS.2017.17.2.107](https://doi.org/10.5391/IJFIS.2017.17.2.107).
- [80] B. E. Demir, R. Bayir, and F. Duran, "Real-time trajectory tracking of an unmanned aerial vehicle using a self-tuning fuzzy proportional integral derivative controller," *Int. J. Micro Air Vehicles*, vol. 8, no. 4, pp. 252–268, Dec. 2016, doi: [10.1177/1756829316675882](https://doi.org/10.1177/1756829316675882).
- [81] S. Alameri, D. Lazić, and M. Ristanovic, "A comparative study of PID, PID with tracking, and FPID controller for missile canard with an optimized genetic tuning method using simscape modelling," *Tehnički vjesnik*, vol. 25, pp. 427–436, Sep. 2018, doi: [10.17559/TV-20171207130458](https://doi.org/10.17559/TV-20171207130458).
- [82] X. Shi, Y. Cheng, C. Yin, S. Dadras, and X. Huang, "Design of fractional-order backstepping sliding mode control for quadrotor UAV," *Asian J. Control*, vol. 21, no. 1, pp. 156–171, Jan. 2019, doi: [10.1002/asjc.1946](https://doi.org/10.1002/asjc.1946).
- [83] R. Ayad, W. Nouibat, M. Zareb, and Y. B. Sebanne, "Full control of quadrotor aerial robot using fractional-order FOPID," *Iranian J. Sci. Technol., Trans. Electr. Eng.*, vol. 43, no. S1, pp. 349–360, Jul. 2019, doi: [10.1007/s40998-018-0155-4](https://doi.org/10.1007/s40998-018-0155-4).
- [84] J. Han, L. Di, C. Coopmans, and Y. Chen, "Pitch loop control of a VTOL UAV using fractional order controller," *J. Intell. Robot. Syst.*, vol. 73, nos. 1–4, pp. 187–195, Jan. 2014, doi: [10.1007/s10846-013-9912-9](https://doi.org/10.1007/s10846-013-9912-9).
- [85] R. Fessi and S. Bouallègue, "LQG controller design for a quadrotor UAV based on particle swarm optimisation," *Int. J. Autom. Control*, vol. 13, no. 5, pp. 569–594, May 2019. Accessed: Feb. 3, 2020. [Online]. Available: <https://www.inderscienceonline.com/doi/abs/10.1504/IJAAC.2019.101910>
- [86] H. Du, W. Zhu, G. Wen, Z. Duan, and J. Lu, "Distributed formation control of multiple quadrotor aircraft based on nonsmooth consensus algorithms," *IEEE Trans. Cybern.*, vol. 49, no. 1, pp. 342–353, Jan. 2019, doi: [10.1109/TCYB.2017.2777463](https://doi.org/10.1109/TCYB.2017.2777463).
- [87] M. A. Smirnova and M. N. Smirnov, "Dynamic modeling and hybrid control design with image tracking for a quadrotor UAV," *Int. J. Appl. Eng. Res.*, vol. 12, no. 15, pp. 5073–5077, 2017.
- [88] A. Noormohammadi-Asl, O. Esrafilian, M. A. Arzati, and H. D. Taghirad, "System identification and H-infinity-based control of quadrotor attitude," *Mech. Syst. Signal Process.*, vol. 135, Jan. 2020, Art. no. 106358, doi: [10.1016/j.ymssp.2019.106358](https://doi.org/10.1016/j.ymssp.2019.106358).
- [89] H. Wang, Z. Li, H. Xiong, and X. Nian, "Robust H ∞ attitude tracking control of a quadrotor UAV on SO(3) via variation-based linearization and interval matrix approach," *ISA Trans.*, vol. 87, pp. 10–16, Apr. 2019, doi: [10.1016/j.isatra.2018.11.015](https://doi.org/10.1016/j.isatra.2018.11.015).
- [90] C. Li, H. Jing, J. Bao, S. Sun, and R. Wang, "Robust H ∞ fault tolerant control for quadrotor attitude regulation," *Proc. Inst. Mech. Eng., I, J. Syst. Control Eng.*, vol. 232, no. 10, pp. 1302–1313, Nov. 2018, doi: [10.1177/0959651818780763](https://doi.org/10.1177/0959651818780763).
- [91] J. P. Ortiz, L. I. Minchala, and M. J. Reinoso, "Nonlinear robust H-infinity PID controller for the multivariable system quadrotor," *IEEE Latin Amer. Trans.*, vol. 14, no. 3, pp. 1176–1183, Mar. 2016, doi: [10.1109/TLA.2016.7459596](https://doi.org/10.1109/TLA.2016.7459596).
- [92] H. Maqsood and Y. Qu, "Nonlinear disturbance observer based sliding mode control of quadrotor helicopter," *J. Electr. Eng. Technol.*, vol. 15, no. 3, pp. 1453–1461, May 2020, doi: [10.1007/s42835-020-00421-w](https://doi.org/10.1007/s42835-020-00421-w).
- [93] K. Wang, C. Hua, J. Chen, and M. Cai, "Dual-loop integral sliding mode control for robust trajectory tracking of a quadrotor," *Int. J. Syst. Sci.*, vol. 51, no. 2, pp. 203–216, Jan. 2020, doi: [10.1080/00207721.2019.1622815](https://doi.org/10.1080/00207721.2019.1622815).
- [94] J. Sanwale, P. Trivedi, M. Kothari, and A. Malagaudanavar, "Quaternion-based position control of a quadrotor unmanned aerial vehicle using robust nonlinear third-order sliding mode control with disturbance cancellation," *Proc. Inst. Mech. Eng., G, J. Aerosp. Eng.*, vol. 234, no. 4, pp. 997–1013, Mar. 2020, doi: [10.1177/0954410019893215](https://doi.org/10.1177/0954410019893215).
- [95] H. Rios, R. Falcon, O. A. Gonzalez, and A. Dzul, "Continuous sliding-mode control strategies for quadrotor robust tracking: Real-time application," *IEEE Trans. Ind. Electron.*, vol. 66, no. 2, pp. 1264–1272, Feb. 2019, doi: [10.1109/TIE.2018.2831191](https://doi.org/10.1109/TIE.2018.2831191).
- [96] A. Eltayeb, M. F. Rahmat, M. A. M. Basri, and M. S. Mahmoud, "An improved design of integral sliding mode controller for chattering attenuation and trajectory tracking of the quadrotor UAV," *Arabian J. Sci. Eng.*, vol. 45, no. 8, pp. 6949–6961, Aug. 2020, doi: [10.1007/s13369-020-04569-5](https://doi.org/10.1007/s13369-020-04569-5).
- [97] G. Perozzi, D. Efimov, J.-M. Biannic, and L. Planckaert, "Trajectory tracking for a quadrotor under wind perturbations: Sliding mode control with state-dependent gains," *J. Franklin Inst.*, vol. 355, no. 12, pp. 4809–4838, Aug. 2018, doi: [10.1016/j.jfranklin.2018.04.042](https://doi.org/10.1016/j.jfranklin.2018.04.042).
- [98] J. Chang, J. Cieslak, J. Dávila, A. Zolghadri, and J. Zhou, "Analysis and design of second-order sliding-mode algorithms for quadrotor roll and pitch estimation," *ISA Trans.*, vol. 71, pp. 495–512, Nov. 2017, doi: [10.1016/j.isatra.2017.09.012](https://doi.org/10.1016/j.isatra.2017.09.012).
- [99] C. Izaguirre-Espinoza, A.-J. Muñoz-Vázquez, A. Sanchez-Orta, V. Parra-Vega, and P. Castillo, "Contact force tracking of quadrotors based on robust attitude control," *Control Eng. Pract.*, vol. 78, pp. 89–96, Sep. 2018, doi: [10.1016/j.conengprac.2018.06.013](https://doi.org/10.1016/j.conengprac.2018.06.013).
- [100] R. Wang and J. Liu, "Trajectory tracking control of a 6-DOF quadrotor UAV with input saturation via backstepping," *J. Franklin Inst.*, vol. 355, no. 7, pp. 3288–3309, May 2018, doi: [10.1016/j.jfranklin.2018.01.039](https://doi.org/10.1016/j.jfranklin.2018.01.039).
- [101] Z. Song and K. Sun, "Adaptive compensation control for attitude adjustment of quad-rotor unmanned aerial vehicle," *ISA Trans.*, vol. 69, pp. 242–255, Jul. 2017, doi: [10.1016/j.isatra.2017.04.003](https://doi.org/10.1016/j.isatra.2017.04.003).
- [102] J. Ghommam, L. F. Luque-Vega, B. Castillo-Toledo, and M. Saad, "Three-dimensional distributed tracking control for multiple quadrotor helicopters," *J. Franklin Inst.*, vol. 353, no. 10, pp. 2344–2372, Jul. 2016, doi: [10.1016/j.jfranklin.2016.04.003](https://doi.org/10.1016/j.jfranklin.2016.04.003).
- [103] M. R. Mokhtari and B. Cherki, "A new robust control for minirotorcraft unmanned aerial vehicles," *ISA Trans.*, vol. 56, pp. 86–101, May 2015, doi: [10.1016/j.isatra.2014.12.003](https://doi.org/10.1016/j.isatra.2014.12.003).
- [104] H. Liu, T. Ma, F. L. Lewis, and Y. Wan, "Robust formation control for multiple quadrotors with nonlinearities and disturbances," *IEEE Trans. Cybern.*, vol. 50, no. 4, pp. 1362–1371, Apr. 2020, doi: [10.1109/TCYB.2018.2875559](https://doi.org/10.1109/TCYB.2018.2875559).
- [105] N. Xuan-Mung and S. K. Hong, "Robust backstepping trajectory tracking control of a quadrotor with input saturation via extended state observer," *Appl. Sci.*, vol. 9, no. 23, p. 5184, Nov. 2019, doi: [10.3390/app9235184](https://doi.org/10.3390/app9235184).
- [106] A.-W.-A. Saif, A. Aliyu, M. A. Dhaifallah, and M. Elshafei, "Decentralized backstepping control of a quadrotor with tilted-rotor under wind gusts," *Int. J. Control, Autom. Syst.*, vol. 16, no. 5, pp. 2458–2472, Oct. 2018, doi: [10.1007/s12555-017-0099-x](https://doi.org/10.1007/s12555-017-0099-x).
- [107] A. Chovancová, T. Fico, P. Hubinský, and F. Duchoň, "Comparison of various quaternion-based control methods applied to quadrotor with disturbance observer and position estimator," *Robot. Auton. Syst.*, vol. 79, pp. 87–98, May 2016, doi: [10.1016/j.robot.2016.01.011](https://doi.org/10.1016/j.robot.2016.01.011).
- [108] J. Hu and A. Lanzon, "An innovative tri-rotor drone and associated distributed aerial drone swarm control," *Robot. Auton. Syst.*, vol. 103, pp. 162–174, May 2018, doi: [10.1016/j.robot.2018.02.019](https://doi.org/10.1016/j.robot.2018.02.019).
- [109] A. Alkamachi and E. Erçelebi, "H ∞ control of an overactuated tilt rotors quadcopter," *J. Central South Univ.*, vol. 25, no. 3, pp. 586–599, Mar. 2018, doi: [10.1007/s11771-018-3763-2](https://doi.org/10.1007/s11771-018-3763-2).
- [110] D. Zhang, H. Qi, X. Wu, Y. Xie, and J. Xu, "The quadrotor dynamic modeling and indoor target tracking control method," *Math. Problems Eng.*, vol. 2014, pp. 1–9, Mar. 2014, doi: [10.1155/2014/637034](https://doi.org/10.1155/2014/637034).

- [111] R. C. Shekhar, M. Kearney, and I. Shames, "Robust model predictive control of unmanned aerial vehicles using waypoints," *J. Guid., Control, Dyn.*, vol. 38, no. 10, pp. 1898–1907, Oct. 2015, doi: [10.2514/1.G000787](https://doi.org/10.2514/1.G000787).
- [112] A. Eskandarpour and I. Sharf, "A constrained error-based MPC for path following of quadrotor with stability analysis," *Nonlinear Dyn.*, vol. 99, no. 2, pp. 899–918, Jan. 2020, doi: [10.1007/s11071-019-04859-0](https://doi.org/10.1007/s11071-019-04859-0).
- [113] G. Williams, A. Aldrich, and E. A. Theodorou, "Model predictive path integral control: From theory to parallel computation," *J. Guid., Control, Dyn.*, vol. 40, no. 2, pp. 344–357, Feb. 2017, doi: [10.2514/1.G001921](https://doi.org/10.2514/1.G001921).
- [114] H. Lu, C. Liu, L. Guo, and W.-H. Chen, "Constrained anti-disturbance control for a quadrotor based on differential flatness," *Int. J. Syst. Sci.*, vol. 48, no. 6, pp. 1182–1193, Apr. 2017, doi: [10.1080/002071721.2016.1244307](https://doi.org/10.1080/002071721.2016.1244307).
- [115] A. Eltayeb, M. F. Rahmat, and M. A. M. Basri, "Adaptive feedback linearization controller for stabilization of quadrotor UAV," *Int. J. Integr. Eng.*, vol. 12, no. 4, pp. 1–17, 2020.
- [116] T. Huang, D. Huang, Z. Wang, and A. Shah, "Robust tracking control of a quadrotor UAV based on adaptive sliding mode controller," *Complexity*, vol. 2019, Dec. 2019, Art. no. 7931632, doi: [10.1155/2019/7931632](https://doi.org/10.1155/2019/7931632).
- [117] O. Mofid and S. Mobayen, "Adaptive sliding mode control for finite-time stability of quad-rotor UAVs with parametric uncertainties," *ISA Trans.*, vol. 72, pp. 1–14, Jan. 2018, doi: [10.1016/j.isatra.2017.11.010](https://doi.org/10.1016/j.isatra.2017.11.010).
- [118] D. W. Kun and I. Hwang, "Linear matrix inequality-based nonlinear adaptive robust control of quadrotor," *J. Guid., Control, Dyn.*, vol. 39, no. 5, pp. 996–1008, May 2016, doi: [10.2514/1.G001439](https://doi.org/10.2514/1.G001439).
- [119] S. Islam, P. X. Liu, and A. E. Saddik, "Observer-based adaptive output feedback control for miniature aerial vehicle," *IEEE Trans. Ind. Electron.*, vol. 65, no. 1, pp. 470–477, Jan. 2018, doi: [10.1109/TIE.2017.2714148](https://doi.org/10.1109/TIE.2017.2714148).
- [120] S. Islam, P. X. Liu, and A. El Saddik, "Nonlinear robust adaptive sliding mode control design for miniature unmanned multirotor aerial vehicle," *Int. J. Control, Autom. Syst.*, vol. 15, no. 4, pp. 1661–1668, Aug. 2017, doi: [10.1007/s12555-016-0013-y](https://doi.org/10.1007/s12555-016-0013-y).
- [121] S. Islam, P. X. Liu, and A. El Saddik, "Robust control of four-rotor unmanned aerial vehicle with disturbance uncertainty," *IEEE Trans. Ind. Electron.*, vol. 62, no. 3, pp. 1563–1571, Mar. 2015, doi: [10.1109/TIE.2014.2365441](https://doi.org/10.1109/TIE.2014.2365441).
- [122] S. Islam, X. P. Liu, and A. E. Saddik, "Adaptive sliding mode control of unmanned four rotor flying vehicle," *Int. J. Robot. Autom.*, vol. 30, no. 2, pp. 140–148, 2015, doi: [10.2316/Journal.206.2015.2.206-3960](https://doi.org/10.2316/Journal.206.2015.2.206-3960).
- [123] M. J. Mahmoodabadi and N. R. Babak, "Robust fuzzy linear quadratic regulator control optimized by multi-objective high exploration particle swarm optimization for a 4 degree-of-freedom quadrotor," *Aerosp. Sci. Technol.*, vol. 97, Feb. 2020, Art. no. 105598, doi: [10.1016/j.ast.2019.105598](https://doi.org/10.1016/j.ast.2019.105598).
- [124] J. Zhang, Z. Ren, C. Deng, and B. Wen, "Adaptive fuzzy global sliding mode control for trajectory tracking of quadrotor UAVs," *Nonlinear Dyn.*, vol. 97, no. 1, pp. 609–627, Jul. 2019, doi: [10.1007/s11071-019-05002-9](https://doi.org/10.1007/s11071-019-05002-9).
- [125] C.-L. Hwang, H.-M. Wu, and J.-Y. Lai, "On-line obstacle detection, avoidance, and mapping of an outdoor quadrotor using EKF-based fuzzy tracking incremental control," *IEEE Access*, vol. 7, pp. 160203–160216, 2019, doi: [10.1109/ACCESS.2019.2950324](https://doi.org/10.1109/ACCESS.2019.2950324).
- [126] M. K. Al-Sharman, B. J. Emran, M. A. Jaradat, H. Najjaran, R. Al-Husari, and Y. Zweiri, "Precision landing using an adaptive fuzzy multi-sensor data fusion architecture," *Appl. Soft Comput.*, vol. 69, pp. 149–164, Aug. 2018, doi: [10.1016/j.asoc.2018.04.025](https://doi.org/10.1016/j.asoc.2018.04.025).
- [127] A. Bounemour, M. Chemachema, and N. Essounbouli, "Indirect adaptive fuzzy fault-tolerant tracking control for MIMO nonlinear systems with actuator and sensor failures," *ISA Trans.*, vol. 79, pp. 45–61, Aug. 2018, doi: [10.1016/j.isatra.2018.04.014](https://doi.org/10.1016/j.isatra.2018.04.014).
- [128] S. Xingling, T. Biao, Y. Wei, and Z. Wendong, "Estimator-based MLP neuroadaptive dynamic surface containment control with prescribed performance for multiple quadrotors," *Aerosp. Sci. Technol.*, vol. 97, Feb. 2020, Art. no. 105620, doi: [10.1016/j.ast.2019.105620](https://doi.org/10.1016/j.ast.2019.105620).
- [129] N. Wang, S.-F. Su, M. Han, and W.-H. Chen, "Backpropagating constraints-based trajectory tracking control of a quadrotor with constrained actuator dynamics and complex unknowns," *IEEE Trans. Syst., Man, Cybern. Syst.*, vol. 49, no. 7, pp. 1322–1337, Jul. 2019, doi: [10.1109/TSMC.2018.2834515](https://doi.org/10.1109/TSMC.2018.2834515).
- [130] H. Razmi and S. Afshinfar, "Neural network-based adaptive sliding mode control design for position and attitude control of a quadrotor UAV," *Aerosp. Sci. Technol.*, vol. 91, pp. 12–27, Aug. 2019, doi: [10.1016/j.ast.2019.04.055](https://doi.org/10.1016/j.ast.2019.04.055).
- [131] E. Khosravian and H. Maghsoudi, "Design of an intelligent controller for station keeping, attitude control, and path tracking of a quadrotor using recursive neural networks," *Int. J. Eng.*, vol. 32, no. 5, pp. 747–758, May 2019, doi: [10.5829/ije.2019.32.05b.17](https://doi.org/10.5829/ije.2019.32.05b.17).
- [132] J. Muliadi and B. Kusumoputro, "Neural network control system of UAV altitude dynamics and its comparison with the PID control system," *J. Adv. Transp.*, vol. 2018, pp. 1–18, Jan. 2018, doi: [10.1155/2018/3823201](https://doi.org/10.1155/2018/3823201).
- [133] C. Fu, W. Hong, H. Lu, L. Zhang, X. Guo, and Y. Tian, "Adaptive robust backstepping attitude control for a multi-rotor unmanned aerial vehicle with time-varying output constraints," *Aerosp. Sci. Technol.*, vol. 78, pp. 593–603, Jul. 2018, doi: [10.1016/j.ast.2018.05.021](https://doi.org/10.1016/j.ast.2018.05.021).
- [134] K. S. Hatamleh, M. Al-Shabi, A. Al-Ghaseem, and A. A. Asad, "Unmanned aerial vehicles parameter estimation using artificial neural networks and iterative bi-section shooting method," *Appl. Soft Comput.*, vol. 36, pp. 457–467, Nov. 2015, doi: [10.1016/j.asoc.2015.06.031](https://doi.org/10.1016/j.asoc.2015.06.031).
- [135] P. Bulucu, M. U. Soydemir, S. Şahin, A. Kocaoğlu, and C. Güzelış, "Learning stable robust adaptive NARMA controller for UAV and its application to twin rotor MIMO systems," *Neural Process. Lett.*, vol. 52, no. 1, pp. 353–383, Aug. 2020, doi: [10.1007/s11063-020-10265-0](https://doi.org/10.1007/s11063-020-10265-0).
- [136] C. Mu and Y. Zhang, "Learning-based robust tracking control of quadrotor with time-varying and coupling uncertainties," *IEEE Trans. Neural Netw. Learn. Syst.*, vol. 31, no. 1, pp. 259–273, Jan. 2020, doi: [10.1109/TNNLS.2019.2900510](https://doi.org/10.1109/TNNLS.2019.2900510).
- [137] M. Ohnishi, L. Wang, G. Notomista, and M. Egerstedt, "Barrier-certified adaptive reinforcement learning with applications to brushbot navigation," *IEEE Trans. Robot.*, vol. 35, no. 5, pp. 1186–1205, Oct. 2019, doi: [10.1109/TRO.2019.2920206](https://doi.org/10.1109/TRO.2019.2920206).
- [138] M. Alabsi and T. Fields, "Flight controller learning based on real-time model estimation of a quadrotor aircraft," *Proc. Inst. Mech. Eng., G, J. Aerosp. Eng.*, vol. 233, no. 9, pp. 3298–3312, Jul. 2019, doi: [10.1177/0954410018795524](https://doi.org/10.1177/0954410018795524).
- [139] Z. Liu, X. Liu, J. Chen, and C. Fang, "Altitude control for variable load quadrotor via learning rate based robust sliding mode controller," *IEEE Access*, vol. 7, pp. 9736–9744, 2019, doi: [10.1109/ACCESS.2018.2890450](https://doi.org/10.1109/ACCESS.2018.2890450).
- [140] A. Carrio, C. Sampedro, A. Rodriguez-Ramos, and P. Campoy, "A review of deep learning methods and applications for unmanned aerial vehicles," *J. Sensors*, vol. 2017, pp. 1–13, Aug. 2017, doi: [10.1155/2017/3296874](https://doi.org/10.1155/2017/3296874).
- [141] G. Bhutani, "Application of machine-learning based prediction techniques in wireless networks," *Int. J. Commun., Netw. Syst. Sci.*, vol. 7, no. 5, pp. 131–140, 2014, doi: [10.4236/ijens.2014.75015](https://doi.org/10.4236/ijens.2014.75015).
- [142] V. Kouhdaragh, F. Verde, G. Gelli, and J. Abouei, "On the application of machine learning to the design of UAV-based 5G radio access networks," *Electronics*, vol. 9, no. 4, p. 689, Apr. 2020, doi: [10.3390/electronics9040689](https://doi.org/10.3390/electronics9040689).
- [143] V. Mahajan, C. Katrakazas, and C. Antoniou, "Prediction of lane-changing maneuvers with automatic labeling and deep learning," *Transp. Res. Rec., J. Transp. Res. Board*, vol. 2674, no. 7, pp. 336–347, Jul. 2020, doi: [10.1177/0361198120922210](https://doi.org/10.1177/0361198120922210).
- [144] E. Panagiotou, G. Chochlakakis, L. Grammatikopoulos, and E. Charou, "Generating elevation surface from a single RGB remotely sensed image using deep learning," *Remote Sens.*, vol. 12, no. 12, p. 2002, Jun. 2020, doi: [10.3390/rs12122002](https://doi.org/10.3390/rs12122002).
- [145] L. Shan, R. Miura, T. Kagawa, F. Ono, H.-B. Li, and F. Kojima, "Machine learning-based field data analysis and modeling for drone communications," *IEEE Access*, vol. 7, pp. 79127–79135, 2019, doi: [10.1109/ACCESS.2019.2922544](https://doi.org/10.1109/ACCESS.2019.2922544).
- [146] A. L. Teske, G. Chen, C. Nansen, and Z. Kong, "Optimised dispensing of predatory mites by multirotor UAVs in wind: A distribution pattern modelling approach for precision pest management," *Biosyst. Eng.*, vol. 187, pp. 226–238, Nov. 2019, doi: [10.1016/j.biosystemseng.2019.09.009](https://doi.org/10.1016/j.biosystemseng.2019.09.009).
- [147] M. M. Ferdous, M. Pratama, S. G. Anavatti, and M. A. Garratt, "Online identification of a rotary wing unmanned aerial vehicle from data streams," *Appl. Soft Comput.*, vol. 76, pp. 313–325, Mar. 2019, doi: [10.1016/j.asoc.2018.12.013](https://doi.org/10.1016/j.asoc.2018.12.013).
- [148] Y.-R. Tang, X. Xiao, and Y. Li, "Nonlinear dynamic modeling and hybrid control design with dynamic compensator for a small-scale UAV quadrotor," *Measurement*, vol. 109, pp. 51–64, Oct. 2017, doi: [10.1016/j.measurement.2017.05.036](https://doi.org/10.1016/j.measurement.2017.05.036).
- [149] Y. Yang, W. Wang, D. Iwakura, A. Namiki, and K. Nonami, "Sliding mode control for hexacopter stabilization with motor failure," *J. Robot. Mechatron.*, vol. 28, no. 6, pp. 936–948, Dec. 2016, doi: [10.20965/jrm.2016.p0936](https://doi.org/10.20965/jrm.2016.p0936).

- [150] E. Thomson, Y. Malhi, H. Bartholomeus, I. Oliveras, A. Gvozdevaite, T. Peprah, J. Suomalainen, J. Quansah, J. Seidu, C. Adonteng, A. Abraham, M. Herold, S. Adu-Bredu, and C. Doughty, "Mapping the leaf economic spectrum across west African tropical forests using UAV-acquired hyperspectral imagery," *Remote Sens.*, vol. 10, no. 10, p. 1532, Sep. 2018, doi: [10.3390/rs10101532](https://doi.org/10.3390/rs10101532).
- [151] O. Tziavou, S. Pytharouli, and J. Souter, "Unmanned aerial vehicle (UAV) based mapping in engineering geological surveys: Considerations for optimum results," *Eng. Geol.*, vol. 232, pp. 12–21, Jan. 2018, doi: [10.1016/j.enggeo.2017.11.004](https://doi.org/10.1016/j.enggeo.2017.11.004).
- [152] E. Lee, H. Yoon, S. P. Hyun, W. C. Burnett, D. Koh, K. Ha, D. Kim, Y. Kim, and K. Kang, "Unmanned aerial vehicles (UAVs)-based thermal infrared (TIR) mapping, a novel approach to assess groundwater discharge into the coastal zone," *Limnology Oceanogr. Methods*, vol. 14, no. 11, pp. 725–735, Nov. 2016, doi: [10.1002/lom3.10132](https://doi.org/10.1002/lom3.10132).
- [153] P. Christian and J. Davis, "Hillslope gully photogeomorphology using structure-from-motion," *Zeitschrift für Geomorphologie, Supplementary Issues*, vol. 60, no. 3, pp. 59–78, Aug. 2016, doi: [10.1127/zfg_suppl/2016/00238](https://doi.org/10.1127/zfg_suppl/2016/00238).
- [154] L. G. T. Crusiol, M. R. Nanni, G. F. C. Silva, R. H. Furlanetto, A. A. da Silva Gualberto, A. D. C. Gasparotto, and M. N. De Paula, "Semi professional digital camera calibration techniques for vis/NIR spectral data acquisition from an unmanned aerial vehicle," *Int. J. Remote Sens.*, vol. 38, nos. 8–10, pp. 2717–2736, May 2017, doi: [10.1080/01431161.2016.1264032](https://doi.org/10.1080/01431161.2016.1264032).
- [155] J. Fernández-Guisuraga, E. Sanz-Ablanedo, S. Suárez-Seoane, and L. Calvo, "Using unmanned aerial vehicles in postfire vegetation survey campaigns through large and heterogeneous areas: Opportunities and challenges," *Sensors*, vol. 18, no. 2, p. 586, Feb. 2018, doi: [10.3390/s18020586](https://doi.org/10.3390/s18020586).
- [156] Y. L. Zabulonov, V. M. Burntyak, L. A. Odukalets, and L. A. Odukalets, "System for effective remote control and monitoring of radiation situation based on unmanned aerial vehicle," *Sci. Innov.*, vol. 13, no. 4, pp. 40–45, Nov. 2017, doi: [10.15407/scine13.04.040](https://doi.org/10.15407/scine13.04.040).
- [157] J. Aurell, W. Mitchell, V. Chirayath, J. Jonsson, D. Tabor, and B. Gullett, "Field determination of multipollutant, open area combustion source emission factors with a hexacopter unmanned aerial vehicle," *Atmos. Environ.*, vol. 166, pp. 433–440, Oct. 2017, doi: [10.1016/j.atmosenv.2017.07.046](https://doi.org/10.1016/j.atmosenv.2017.07.046).
- [158] A. Apprill, C. A. Miller, M. J. Moore, J. W. Durban, H. Fearnbach, and L. G. Barrett-Lennard, "Extensive core microbiome in drone-captured whale blow supports a framework for health monitoring," *mSystems*, vol. 2, no. 5, pp. 1–15, Oct. 2017, doi: [10.1128/mSystems.00119-17](https://doi.org/10.1128/mSystems.00119-17).
- [159] P. Božek, A. M. Al Akkad, P. Blištan, and I. N. Ibrahim, "Navigation control and stability investigation of a mobile robot based on a hexacopter equipped with an integrated manipulator," *Int. J. Adv. Robot. Syst.*, vol. 14, no. 6, pp. 1–13, Nov. 2017, doi: [10.1177/1729881417738103](https://doi.org/10.1177/1729881417738103).
- [160] A. Alaimo, V. Artale, G. Barbaraci, C. L. R. Milazzo, C. Orlando, and A. Ricciardello, "LQR-PID control applied to hexacopter flight," *J. Numer. Anal., Ind. Appl. Math.*, vols. 9–10, nos. 3–4, pp. 47–56, 2016.
- [161] N. P. Nguyen, N. X. Mung, and S. K. Hong, "Actuator fault detection and fault-tolerant control for hexacopter," *Sensors*, vol. 19, no. 21, p. 4721, Oct. 2019, doi: [10.3390/s19214721](https://doi.org/10.3390/s19214721).
- [162] J. Y. S. Lee, K. K. Leang, and W. Yim, "Design and control of a fully-actuated hexrotor for aerial manipulation applications," *J. Mech. Robot.*, vol. 10, no. 4, pp. 041007-1–041007-10, Apr. 2018, doi: [10.1115/1.4039854](https://doi.org/10.1115/1.4039854).
- [163] H. Lee and H. J. Kim, "Constraint-based cooperative control of multiple aerial manipulators for handling an unknown payload," *IEEE Trans. Ind. Informat.*, vol. 13, no. 6, pp. 2780–2790, Dec. 2017, doi: [10.1109/TII.2017.2692270](https://doi.org/10.1109/TII.2017.2692270).
- [164] Y. Yang, D. Iwakura, A. Namiki, K. Nonami, and W. Wang, "Autonomous flight of hexacopter under propulsion system failure," *J. Robot. Mechatron.*, vol. 28, no. 6, pp. 899–910, Dec. 2016, doi: [10.20965/jrm.2016.p0899](https://doi.org/10.20965/jrm.2016.p0899).
- [165] J. Zhang, D. Gu, C. Deng, and B. Wen, "Robust and adaptive backstepping control for hexacopter UAVs," *IEEE Access*, vol. 7, pp. 163502–163514, 2019, doi: [10.1109/ACCESS.2019.2951282](https://doi.org/10.1109/ACCESS.2019.2951282).
- [166] J. Lee, H. S. Choi, and H. Shim, "Fault tolerant control of hexacopter for actuator faults using time delay control method," *Int. J. Aeronaut. Space Sci.*, vol. 17, no. 1, pp. 54–63, Mar. 2016, doi: [10.5139/IJASS.2016.17.1.54](https://doi.org/10.5139/IJASS.2016.17.1.54).
- [167] M. M. Ferdaus, M. Pratama, S. G. Anavatti, M. A. Garratt, and E. Lughofer, "PAC: A novel self-adaptive neuro-fuzzy controller for micro aerial vehicles," *Inf. Sci.*, vol. 512, pp. 481–505, Feb. 2020, doi: [10.1016/j.ins.2019.10.001](https://doi.org/10.1016/j.ins.2019.10.001).
- [168] M. M. Ferdaus, M. Pratama, S. G. Anavatti, M. A. Garratt, and Y. Pan, "Generic evolving self-organizing neuro-fuzzy control of bio-inspired unmanned aerial vehicles," Feb. 2018, *arXiv:1802.00635*. Accessed: Jun. 19, 2019. [Online]. Available: <http://arxiv.org/abs/1802.00635>
- [169] P. D. H. Nguyen, C. T. Recchiuto, and A. Sgorbissa, "Real-time path generation and obstacle avoidance for multirotors: A novel approach," *J. Intell. Robot. Syst.*, vol. 89, nos. 1–2, pp. 27–49, Jan. 2018, doi: [10.1007/s10846-017-0478-9](https://doi.org/10.1007/s10846-017-0478-9).
- [170] C. Rosales, C. M. Soria, and F. G. Rossomando, "Identification and adaptive PID control of a hexacopter UAV based on neural networks," *Int. J. Adapt. Control Signal Process.*, vol. 33, no. 1, pp. 74–91, Jan. 2019, doi: [10.1002/acs.2955](https://doi.org/10.1002/acs.2955).
- [171] V. Artale, M. Collotta, C. Milazzo, G. Pau, and A. Ricciardello, "An integrated system for UAV control using a neural network implemented in a prototyping board," *J. Intell. Robot. Syst.*, vol. 84, nos. 1–4, pp. 5–19, Dec. 2016, doi: [10.1007/s10846-015-0324-x](https://doi.org/10.1007/s10846-015-0324-x).
- [172] A. Abadi, A. E. Amraoui, H. Mekki, and N. Ramdani, "Robust tracking control of quadrotor based on flatness and active disturbance rejection control," *IET Control Theory Appl.*, vol. 14, no. 8, pp. 1057–1068, May 2020, doi: [10.1049/iet-cta.2019.1363](https://doi.org/10.1049/iet-cta.2019.1363).
- [173] A. A. Najm and I. K. Ibraheem, "Altitude and attitude stabilization of UAV quadrotor system using improved active disturbance rejection control," *Arabian J. Sci. Eng.*, vol. 45, no. 3, pp. 1985–1999, Mar. 2020, doi: [10.1007/s13369-020-04355-3](https://doi.org/10.1007/s13369-020-04355-3).
- [174] Y. Zhang, Z. Chen, M. Sun, and X. Zhang, "Trajectory tracking control of a quadrotor UAV based on sliding mode active disturbance rejection control," *Nonlinear Anal., Model. Control*, vol. 24, no. 4, pp. 545–560, Jun. 2019, doi: [10.15388/NA.2019.4.4](https://doi.org/10.15388/NA.2019.4.4).
- [175] J. R. Hewit and J. S. Burdess, "Fast dynamic decoupled control for robotics, using active force control," *Mechanism Mach. Theory*, vol. 16, no. 5, pp. 535–542, Jan. 1981, doi: [10.1016/0094-114X\(81\)90025-2](https://doi.org/10.1016/0094-114X(81)90025-2).
- [176] H. Ramli, W. Kuntjoro, M. S. Meon, and K. M. A. K. Ishak, "Adaptive active force control application to twin rotor MIMO system," *Appl. Mech. Mater.*, vol. 393, pp. 688–693, Sep. 2013, doi: [10.4028/www.scientific.net/AMM.393.688](https://doi.org/10.4028/www.scientific.net/AMM.393.688).
- [177] M. S. Meon, T. L. T. Mohamed, M. H. M. Ramli, M. Z. Mohamed, and N. F. A. Manan, "Review and current study on new approach using PID active force control (PIDAFC) of twin rotor multi input multi output system (TRMS)," in *Proc. IEEE Symp. Humanities, Sci. Eng. Res.*, Jun. 2012, pp. 163–167, doi: [10.1109/SHUSER.2012.6268848](https://doi.org/10.1109/SHUSER.2012.6268848).
- [178] S. I. Abdelmaksoud, M. Mailah, and A. M. Abdallah, "Robust intelligent self-tuning active force control of a quadrotor with improved body jerk performance," *IEEE Access*, vol. 8, pp. 150037–150050, 2020, doi: [10.1109/ACCESS.2020.3015101](https://doi.org/10.1109/ACCESS.2020.3015101).
- [179] T. Kusznir and J. Smoczek, "Sliding mode-based control of a UAV quadrotor for suppressing the cable-suspended payload vibration," *J. Control Sci. Eng.*, vol. 2020, Jan. 2020, Art. no. 5058039, doi: [10.1155/2020/5058039](https://doi.org/10.1155/2020/5058039).
- [180] G. Yu, D. Cabecinhas, R. Cunha, and C. Silvestre, "Nonlinear backstepping control of a quadrotor-slung load system," *IEEE/ASME Trans. Mechatronics*, vol. 24, no. 5, pp. 2304–2315, Oct. 2019, doi: [10.1109/TMECH.2019.2930211](https://doi.org/10.1109/TMECH.2019.2930211).
- [181] B. Xian, S. Wang, and S. Yang, "Nonlinear adaptive control for an unmanned aerial payload transportation system: Theory and experimental validation," *Nonlinear Dyn.*, vol. 98, no. 3, pp. 1745–1760, Nov. 2019, doi: [10.1007/s11071-019-05283-0](https://doi.org/10.1007/s11071-019-05283-0).
- [182] E. L. de Angelis, F. Giulietti, and G. Pipeleers, "Two-time-scale control of a multirotor aircraft for suspended load transportation," *Aerosp. Sci. Technol.*, vol. 84, pp. 193–203, Jan. 2019, doi: [10.1016/j.ast.2018.10.012](https://doi.org/10.1016/j.ast.2018.10.012).
- [183] D. Shi, Z. Wu, and W. Chou, "Harmonic extended state observer based anti-swing attitude control for quadrotor with slung load," *Electronics*, vol. 7, no. 6, p. 83, May 2018, doi: [10.3390/electronics7060083](https://doi.org/10.3390/electronics7060083).
- [184] X. Liang, Y. Fang, N. Sun, and H. Lin, "Dynamics analysis and time-optimal motion planning for unmanned quadrotor transportation systems," *Mechatronics*, vol. 50, pp. 16–29, Apr. 2018, doi: [10.1016/j.mechatronics.2018.01.009](https://doi.org/10.1016/j.mechatronics.2018.01.009).
- [185] M. E. Guerrero-Sánchez, D. A. Mercado-Ravell, R. Lozano, and C. D. García-Beltrán, "Swing-attenuation for a quadrotor transporting a cable-suspended payload," *ISA Trans.*, vol. 68, pp. 433–449, May 2017, doi: [10.1016/j.isatra.2017.01.027](https://doi.org/10.1016/j.isatra.2017.01.027).

- [186] M. Bhargavapuri, S. R. Sahoo, M. Kothari, and Abhishek, "Robust nonlinear control of a variable-pitch quadrotor with the flip maneuver," *Control Eng. Pract.*, vol. 87, pp. 26–42, Jun. 2019, doi: [10.1016/j.conengprac.2019.03.012](https://doi.org/10.1016/j.conengprac.2019.03.012).
- [187] Y. Liu, S. Rajappa, J. M. Montenbruck, P. Stegagno, H. Bölhoff, F. Allgöwer, and A. Zell, "Robust nonlinear control approach to non-trivial maneuvers and obstacle avoidance for quadrotor UAV under disturbances," *Robot. Auton. Syst.*, vol. 98, pp. 317–332, Dec. 2017, doi: [10.1016/j.robot.2017.08.011](https://doi.org/10.1016/j.robot.2017.08.011).
- [188] X. Dai, Y. Mao, T. Huang, N. Qin, D. Huang, and Y. Li, "Automatic obstacle avoidance of quadrotor UAV via CNN-based learning," *Neurocomputing*, vol. 402, pp. 346–358, Aug. 2020, doi: [10.1016/j.neucom.2020.04.020](https://doi.org/10.1016/j.neucom.2020.04.020).
- [189] Y. Huang, W. Liu, B. Li, Y. Yang, and B. Xiao, "Finite-time formation tracking control with collision avoidance for quadrotor UAVs," *J. Franklin Inst.*, vol. 357, no. 7, pp. 4034–4058, May 2020, doi: [10.1016/j.jfranklin.2020.01.014](https://doi.org/10.1016/j.jfranklin.2020.01.014).
- [190] S. H. Arul and D. Manocha, "DCAD: Decentralized collision avoidance with dynamics constraints for agile quadrotor swarms," *IEEE Robot. Autom. Lett.*, vol. 5, no. 2, pp. 1191–1198, Apr. 2020, doi: [10.1109/LRA.2020.2967281](https://doi.org/10.1109/LRA.2020.2967281).
- [191] B. N. AbdulSamed, A. A. Aldair, and A. Al-Mayyahi, "Robust trajectory tracking control and obstacles avoidance algorithm for quadrotor unmanned aerial vehicle," *J. Electr. Eng. Technol.*, vol. 15, no. 2, pp. 855–868, Mar. 2020, doi: [10.1007/s42835-020-00350-8](https://doi.org/10.1007/s42835-020-00350-8).
- [192] X. Yang, H. Luo, Y. Wu, Y. Gao, C. Liao, and K.-T. Cheng, "Reactive obstacle avoidance of monocular quadrotors with online adapted depth prediction network," *Neurocomputing*, vol. 325, pp. 142–158, Jan. 2019, doi: [10.1016/j.neucom.2018.10.019](https://doi.org/10.1016/j.neucom.2018.10.019).
- [193] J. Park and N. Cho, "Collision avoidance of hexacopter UAV based on LiDAR data in dynamic environment," *Remote Sens.*, vol. 12, no. 6, p. 975, Mar. 2020, doi: [10.3390/rs12060975](https://doi.org/10.3390/rs12060975).
- [194] H.-C. Chen, "Monocular vision-based obstacle detection and avoidance for a multicopter," *IEEE Access*, vol. 7, pp. 167869–167883, 2019, doi: [10.1109/ACCESS.2019.2953954](https://doi.org/10.1109/ACCESS.2019.2953954).
- [195] S. A. Emami and A. Banazadeh, "Fault-tolerant predictive trajectory tracking of an air vehicle based on acceleration control," *IET Control Theory Appl.*, vol. 14, no. 5, pp. 750–762, Mar. 2020, doi: [10.1049/iet-cta.2019.0596](https://doi.org/10.1049/iet-cta.2019.0596).
- [196] B. Wang, Y. Shen, and Y. Zhang, "Active fault-tolerant control for a quadrotor helicopter against actuator faults and model uncertainties," *Aerosp. Sci. Technol.*, vol. 99, Apr. 2020, Art. no. 105745, doi: [10.1016/j.ast.2020.105745](https://doi.org/10.1016/j.ast.2020.105745).
- [197] S. Mallavalli and A. Fekih, "A fault tolerant tracking control for a quadrotor UAV subject to simultaneous actuator faults and exogenous disturbances," *Int. J. Control*, vol. 93, no. 3, pp. 655–668, Mar. 2020, doi: [10.1080/00207179.2018.1484173](https://doi.org/10.1080/00207179.2018.1484173).
- [198] X. Nian, W. Chen, X. Chu, and Z. Xu, "Robust adaptive fault estimation and fault tolerant control for quadrotor attitude systems," *Int. J. Control*, vol. 93, no. 3, pp. 725–737, Mar. 2020, doi: [10.1080/00207179.2018.1484573](https://doi.org/10.1080/00207179.2018.1484573).
- [199] G. P. Falconi, J. Angelov, and F. Holzapfel, "Adaptive fault-tolerant position control of a hexacopter subject to an unknown motor failure," *Int. J. Appl. Math. Comput. Sci.*, vol. 28, no. 2, pp. 309–321, Jun. 2018, doi: [10.2478/amcs-2018-0022](https://doi.org/10.2478/amcs-2018-0022).
- [200] W. Khawaja, I. Guvenc, D. W. Matolak, U.-C. Fiebig, and N. Schneckenburger, "A survey of air-to-ground propagation channel modeling for unmanned aerial vehicles," *IEEE Commun. Surveys Tuts.*, vol. 21, no. 3, pp. 2361–2391, 3rd Quart., 2019, doi: [10.1109/COMST.2019.2915069](https://doi.org/10.1109/COMST.2019.2915069).
- [201] D. Rieth, C. Heller, and G. Ascheid, "Aircraft to ground-station C-band channel—Small airport scenario," *IEEE Trans. Veh. Technol.*, vol. 68, no. 5, pp. 4306–4315, May 2019, doi: [10.1109/TVT.2019.2904661](https://doi.org/10.1109/TVT.2019.2904661).
- [202] C. She, C. Liu, T. Q. S. Quek, C. Yang, and Y. Li, "Ultra-reliable and low-latency communications in unmanned aerial vehicle communication systems," *IEEE Trans. Commun.*, vol. 67, no. 5, pp. 3768–3781, May 2019, doi: [10.1109/TCOMM.2019.2896184](https://doi.org/10.1109/TCOMM.2019.2896184).
- [203] K. Harikumar, J. Senthilnath, and S. Sundaram, "Multi-UAV oxymyrrhis marina-inspired search and dynamic formation control for forest fire-fighting," *IEEE Trans. Autom. Sci. Eng.*, vol. 16, no. 2, pp. 863–873, Apr. 2019, doi: [10.1109/TASE.2018.2867614](https://doi.org/10.1109/TASE.2018.2867614).
- [204] D. Darsena, G. Gelli, I. Iudice, and F. Verde, "Equalization techniques of control and non-payload communication links for unmanned aerial vehicles," *IEEE Access*, vol. 6, pp. 4485–4496, 2018, doi: [10.1109/ACCESS.2018.2791098](https://doi.org/10.1109/ACCESS.2018.2791098).
- [205] Quanser, Markham, ON, Canada. (2016). *Quanser 2 DOF Helicopter User and Control Manual*. [Online]. Available: <https://www.quanser.com/products/quanser-aero/>
- [206] Pixhawk | The Hardware Standard for Open-Source Autopilots. Accessed: Jul. 20, 2020. [Online]. Available: <https://pixhawk.org/>
- [207] A. Beg, A. R. Qureshi, T. Sheltami, and A. Yasar, "UAV-enabled intelligent traffic policing and emergency response handling system for the smart city," *Pers. Ubiquitous Comput.*, Feb. 2020, pp. 1–18, doi: [10.1007/s00779-019-01297-y](https://doi.org/10.1007/s00779-019-01297-y).
- [208] *I-DOF Copter—Acrome Robotics*. Accessed: Apr. 14, 2020. [Online]. Available: <https://acrone.net/helicopter#>
- [209] L. Buşoniu, V. S. Varma, J. Lohéac, A. Codrean, O. Ştefan, I.-C. Morărescu, and S. Lasaulce, "Learning control for transmission and navigation with a mobile robot under unknown communication rates," *Control Eng. Pract.*, vol. 100, Jul. 2020, Art. no. 104460, doi: [10.1016/j.conengprac.2020.104460](https://doi.org/10.1016/j.conengprac.2020.104460).
- [210] J. Shahmoradi, E. Talebi, P. Roghanchi, and M. Hassanalani, "A comprehensive review of applications of drone technology in the mining industry," *Drones*, vol. 4, no. 3, p. 34, Jul. 2020, doi: [10.3390/drones4030034](https://doi.org/10.3390/drones4030034).
- [211] *Parrot Store Official*. Accessed: Jul. 18, 2020. [Online]. Available: <https://www.parrot.com/us/>
- [212] Z. Zhou, H. Wang, Z. Hu, Y. Wang, and H. Wang, "A multi-time-scale finite time controller for the quadrotor UAVs with uncertainties," *J. Intell. Robot. Syst.*, vol. 94, no. 2, pp. 521–533, May 2019, doi: [10.1007/s10846-018-0837-1](https://doi.org/10.1007/s10846-018-0837-1).



SHERIF I. ABDELMAKSOU received the M.S. degree in aerospace engineering from the King Fahd University of Petroleum and Minerals (KFUPM), Saudi Arabia, in 2015. He is currently pursuing the Ph.D. degree with the School of Mechanical Engineering, Universiti Teknologi Malaysia (UTM), Malaysia. His research interests include dynamic systems modeling, active force control, active vibration control, intelligent control systems, and autonomous unmanned aerial vehicles (UAVs).



MUSA MAILAH (Senior Member, IEEE) received the B.Eng. degree in mechanical engineering from Universiti Teknologi Malaysia (UTM), in 1988, and the M.Sc. degree in mechatronics and the Ph.D. degree in robot control and mechatronics from the University of Dundee, U.K., in 1992 and 1998, respectively. He is a registered Chartered Engineer (C.Eng.), U.K. He is currently a Professor with the School of Mechanical Engineering, Faculty of Engineering, UTM, where he is currently the Head of the Intelligent Control and Automation (iCA) Research Group. His research interests include intelligent systems, the active force control of dynamical systems, robot control, mobile manipulators, applied mechatronics, and industrial automation.



AYMAN M. ABDALLAH received the B.S. and M.S. degrees in aerospace engineering from the King Fahd University of Petroleum and Minerals (KFUPM), Dhahran, Saudi Arabia, and the Ph.D. degree in aerospace engineering from Old Dominion University, Norfolk, VA, USA, in 2015. He is currently an Assistant Professor and the Chairman of the Department of Aerospace Engineering, KFUPM. His research interests include new concept for aerodynamic attitude flight envelope, aircraft nonlinearity assessment, and flight dynamics and control.