

Acoustic Partial Discharge Detection Using Low-cost Pre-amplified Piezoelectric Transducer and Coated Optical Fiber Sensor

C. L. G. Pavan Kumar¹, I. Arizu¹, A. H. M. Nasib¹, M. H. Ahmad¹, Z. Nawawi², M. A. B. Sidik², M. I. Jambak², R. F. Kurnia², M. Y. Mohd Noor³, A. I. Azmi³, E. P. Waldi⁴, Aulia⁴

¹Institute of High Voltage and Current, School of Electrical Engineering, Faculty of Engineering, Universiti Teknologi Malaysia, Johor Bahru, Johor, Malaysia

²Department of Electrical Engineering, Faculty of Engineering, Universitas Sriwijaya, Ogan Ilir, West Sumatera, Indonesia

³Department of Communication Engineering, School of Electrical Engineering, Faculty of Engineering, Universiti Teknologi Malaysia, Johor Bahru, Johor, Malaysia

⁴Department of Electrical Engineering, Andalas University, Padang, West Sumatera, Indonesia
nawawi_z@yahoo.com

Abstract— Partial discharges (PD) occur in high voltage equipment are considered as major problem that required to be prevented to avoid any breakdown, damage and loss from happening. In addition, this pre-breakdown phenomenon can be detected using appropriate sensors such as acoustic emission sensor. In this study, acoustic emission sensor was chosen as the method to detect the PD in high voltage insulation. Low-cost piezoelectric transducer (PZT) with pre-amplifier and optical fiber sensor (OFS) were used as a sensing device to detect PD but OFS was expected to highlight its usage towards PD detection. Development of optical fiber sensor (OFS) based on Single Mode-Multi Mode-Single Mode (SMS) structure which implementing a Multimode Interference effects (MMI) was focused on. PD measurement test was conducted according to IEC 60270 and IEC TS 62478 standards. A coated SMS based OFS was fabricated and then was used in PD measurement test. Furthermore, after implementing the pre-amplified PZT sensor and coated OFS in PD measurement test, results were compared with a measuring impedance by analyzing the Phase Resolved Partial Discharge (PRPD) patterns. From the results, all sensors can detect PD as accurately as the MI but the usage of pre-amplifier on PZT has shown a great deal of advantage in removing noises and amplifying small signal, but the SMS coated OFS has shown similar ability in detecting the PD.

Keywords—partial discharges; acoustic; piezoelectric transducer; fiber optic; SMS structure; multimode interference.

I. INTRODUCTION

Partial discharge is an electrical phenomenon which could cause insulation degradation in high voltage power equipment due to the accumulating effect of mechanical, thermal and electrical stresses over a period of time. Therefore, PD detection during the entire equipment's lifetime is considered as a major step in ensuring a long lifespan for the equipment. From the PD generation process, some physical effects are generated, such as, conducted and radiated electromagnetic pulses, light, acoustic noise, localized temperature variation and chemical changes [1]. Popular methods have been implemented to detect PDs and are grouped into three (3) categories: electrical, chemical and acoustical. In practice for the acoustical detection which falls under the non-conventional method, PD is detected based on IEC 60270 and IEC TS 62478 standards.

Traditionally, piezoelectric transducers (PZT) dominate the sensors that currently being used. Acoustic sensors are well known best with their potential to convert acoustic energy into an electrical signal. Since PZT sensor is small and thin, they have the capability to be attached at the transformer and Gas Insulated Switchgear (GIS) wall and have been extensively used in PD detection. However, these sensors are not immune to electromagnetic interference. The exact positioning of PD is therefore limited and multiple sensors must be used to exactly pinpoint the discharge location.

The drawbacks of PZT's implementation can somehow through the advancement of fiber optic technology as clear benefits are provided in such applications. It may be used because of its small size or can be multiplexed along the length of a single fiber by using light wavelength shift, or by sensing the time delay as light passes along the fiber [2]. Additionally, this sensor can be designed to withstand high temperature when it is embedded in the power equipment for remote applications and offering high sensitivity in locating location of the PD because it can be deployed closely to the source of the discharges [2, 3]. This sensor possesses the biggest advantage as it is immune to electromagnetic interference (EMI) and does not carry electrical quantities. Hence, fiber optic can be chemically and electrically used in places with a high electric field strength and will not disrupt the performance of the equipment being tested.

Recently, the MMI occurring in a fiber-hetero structure configuration known as SMS fiber structure in which a MMF is spliced between two SMFs have been studied and developed to act as novel optical devices such as sensors or filters. Waluyo and Bayuwati have concluded that SMS sensor has the potential for monitoring vibration in an RF-noisy condition, spark-prone environment, and remote location from the monitoring station due to the inherent optical fiber sensor advantages [4]. These advantages include high compactness, wide wavelength operation range, low cost, ease of fabrication and ease of packaging. In similar research, Sun et al employed an SMS structure as a high sensitive optical fiber microphone which can detect human voice within 2-meter range meanwhile Wu et al used a bent SMS structure for vibration sensing [5, 6].

As for PD monitoring by using fiber optic, Deng et al discovered that the signal amplitude has a strong

dependence on the location distance between the sensor and the PD source [7]. Al Saedi et al also highlighted that OFS has good sensitivity and suggested that MMF are able to act as acoustic sensor with a large wide band of the signals [8]. However, the ability of the coated SMS based OFS for the PD detection application has yet been explored. Thus, this study aimed to design a SMS coated OFS and compared the result of the analysis with the low-cost pre-amplified PZT sensor for measuring the PD patterns.

II. METHODOLOGY

A. Piezoelectric Transducer

The industrialized R15i-AST acoustic sensors Physical Acoustics-MISTRAS Group are currently being utilized in detecting acoustic wave caused by PD since its bandwidth can cover the frequency range of the acoustic emission (AE). Due to its high cost, other piezoelectric transducers are rather being considered which are the piezoelectric diaphragm and piezoelectric ceramic. However, these alternative transducers do not have the capability to detect high frequencies of acoustic waves due its low resonance frequency. Hence, an external preamplifier was introduced. The preamplifier circuit represented in Fig. 1 was fabricated with a high pass filtering ability at lower cut off frequency of 31 kHz.

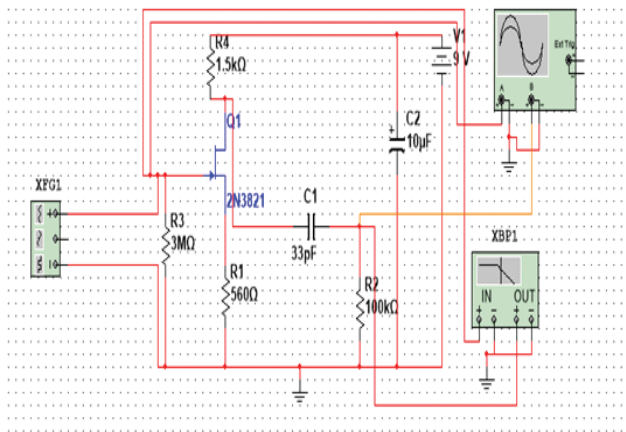

Fig. 1: Schematic diagram of PZT preamplifier

B. Optical Fiber Sensor

Due to the biggest advantages of having immunity towards EMI, fiber optic has been acknowledged as an ideal sensor to detect PD from the acoustic detection method. SMS structure based on MMI effects that yet to make a breakthrough in high voltage testing are considered. Design was finalized and the OFS sensor consists of 9/125 μm SMF spliced together at both ends of a 105/125 μm MMF with no offset between them. The SMF length was set constant at 3 cm whereby the MMF was cut into two 6 cm length with unremoved coating as shown in Fig. 2.



Fig. 2: Coated SMS fiber structure with MMF property.

Fibers was cleaved by using Optical Fiber Cleaver (S326) from Furukawa Electric Co., LTD and was cleaned with propanol. Splicing process was completed by using Fusion Splicer (S178A, V2) from the same manufacturer which was set to auto splicing mode. Finally, the sensor was attached to two separate electrical plastic conduits to prevent the fibers from breaking.

C. PD Measurement Test

The coated SMS based OFS is then used with PZTs in the PD measurement test. As for the experimental setup for the PD measurement test that are represented in Fig. 3, instead of connecting the photodetector to the DAQ card, it was connected directly to a digital oscilloscope through a BNC cable. PZT that has been connected to the preamplifier was attached to the wall of the test cell of the PD experiment and must be covered entirely with the remove EMI from surrounding. MI was used as reference, a ratio between the fabricated sensors and MI are to be expected. Then, high voltage was applied on the test cell and the voltage was maintained at 20 kV for 10 minutes until the discharges occur. PD monitoring is achieved by observing the digital oscilloscope and data were recorded by LabVIEW. PD parameters were analyzed and PRPD patterns were recorded for further analysis.

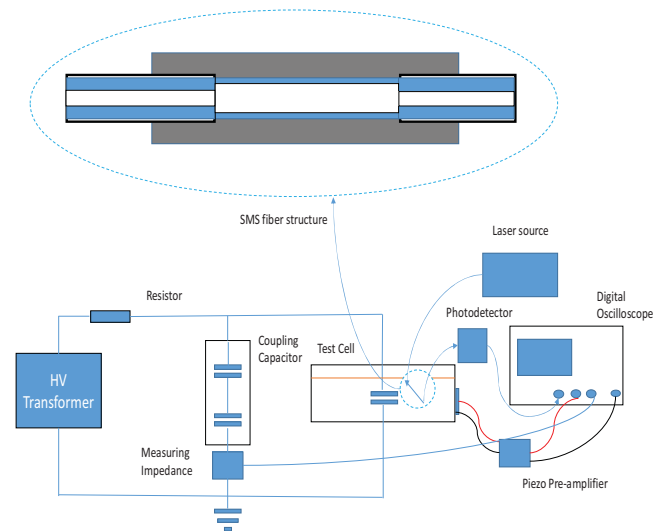

Fig. 3: PD measurement test set up

III. RESULTS AND ANALYSIS

A. PD Measurement Test

The data collection using piezoelectric diaphragm were conducted with and without the use of a preamplifier and was compared to the MI. Fig. 4 and Fig. 5 show the detected PD by MI and the unpre-amplified piezoelectric diaphragm respectively. It can be clearly seen that the piezoelectric diaphragm was able to recognize PD as the commercial detector at the first and third quadrant of the sinusoidal waveform and some PDs occur at the peak. However, bad contact noises are present between the transitions of these two quadrants as marked in the circle in Fig. 8.

From the PD pattern in Fig. 5, the detected discharges are not great in numbers compare with the MI. Some contributing factors that could lead to the low level of detected PD pulses is due to PD that has a lower level of signal. This low signal can however be detected once the preamplifier is introduced and the results shows a greater occurrence of PD as shown in Fig. 6. The highest positive peak recorded for the pre-amplified signal is around 25 mV compared to the unamplified signal with a value of 16 mV. Noises shown in previous figure are also filtered out in addition to the features of the preamplifier.

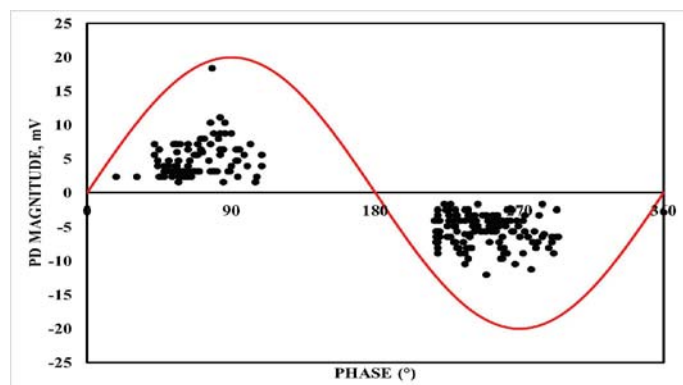

Fig 4: Detected PD using Measuring Impedance

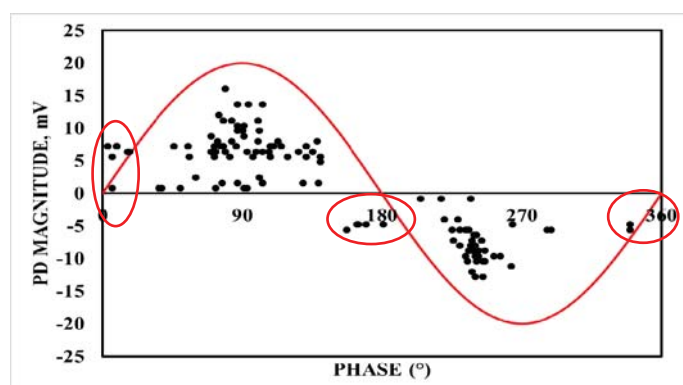

Fig 5: Detected PD using unamplified Piezoelectric Diaphragm

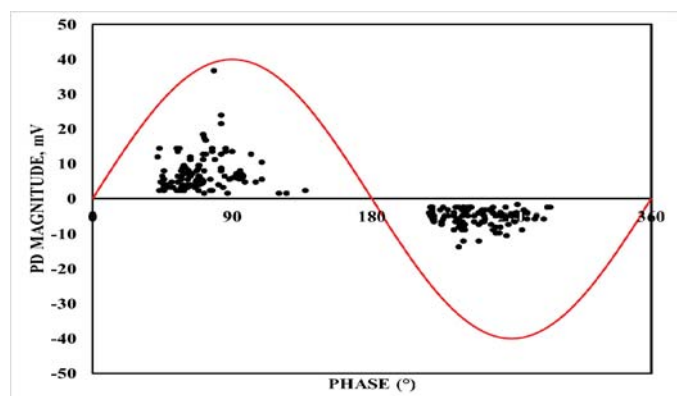

Fig 6: Detected PD using pre-amplified Piezoelectric Diaphragm

Similar patterns are shown with the use the unpre-amplified and pre-amplified piezoelectric ceramic. However, piezoelectric ceramic was capable to detect PD as accurately as the MI despite of being amplified or not. MI averagely detects PD at 8mV of positive peak and at -15 mV

of negative peak and the unamplified piezoelectric ceramic records about the same value as shown in Fig. 7 and Fig. 8 respectively. In term of PD pattern, the piezoelectric ceramic was able to sense more PD pulses compared to the MI.

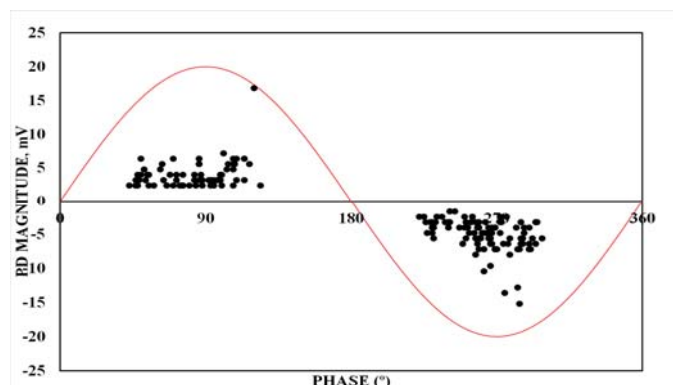

Fig 7: Detected PD using Measuring Impedance

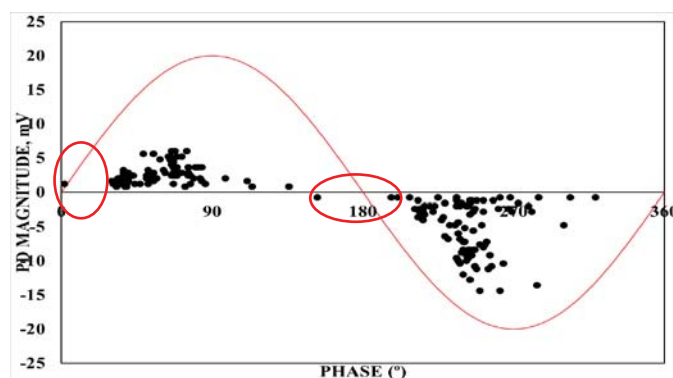

Fig 8: Detected PD using unamplified Piezoelectric Ceramic

By definition, the introduction of preamplifier to the piezoelectric ceramic should also resulted in higher values of peak voltage and more PD pulses to be detected and it was shown in Fig. 9. The highest peak voltages at the positive cycle and the negative cycle for the pre-amplified piezoelectric ceramic were recorded at 38 mV and -48 mV respectively.

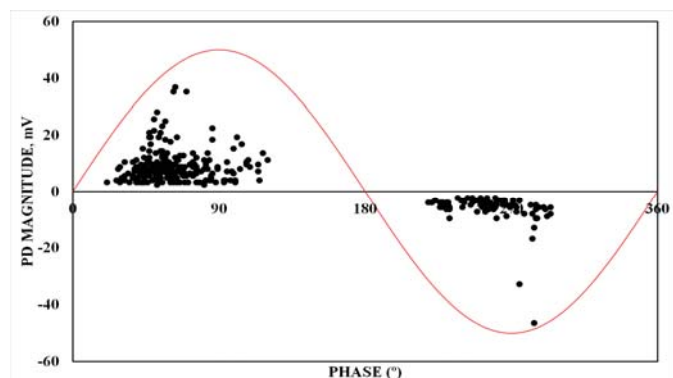

Fig 9: Detected PD using pre-amplified Piezoelectric Ceramic

Similar with the former PZT sensors, results from OFS in PD measurement test were compared with the MI and the results were shown in Fig. 10 and Fig. 11 respectively. Since the OFS inherits the biggest advantage of having immunity against EMI and has high tolerance for noise, the

use of preamplifier was not needed. From the displayed pattern, PD pulses are extensively detected by the OFS as well as the MI.

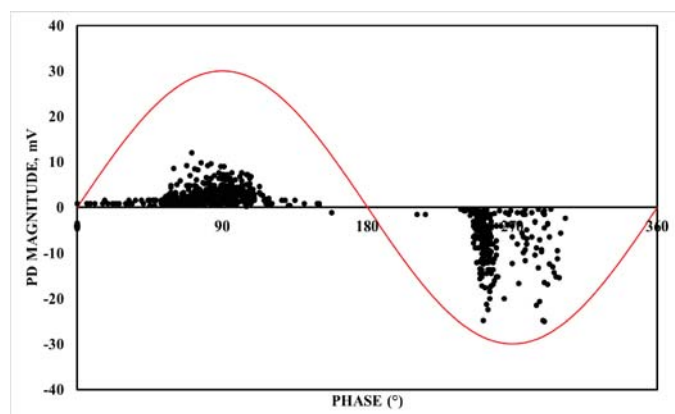

Fig 10: Detected PD using Measuring Impedance

To summarize the results from these works, the use of PZTs without a preamplifier were fully able to detect PD as much as MI but the pulses are rather dispersed and includes the detection of the noise from the surrounding. The introduction of preamplifier to the PZT has improved PD detection by amplifying the small PD signal and filtering out the noises. In terms of PD patterns under the point of occurrence in the first and third quadrant, PD detection using piezoelectric ceramic leads the piezoelectric diaphragm by far. However, OFS has highlighted its forwarding advantages as it was immune to noised and detected the PD pulses as compared to the former sensors used in this experiment.

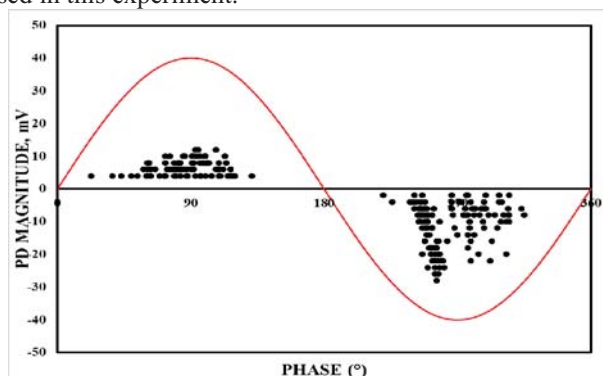

Fig 11: Detected PD using Optical Fiber Sensor

IV. CONCLUSION

As conclusions, both PZT and OFS are fabricated and experimented successfully. The data extraction and results evaluation from the fabricated sensors have been affluently obtained from the usage of LabVIEW software. Plus, the performance of the fabricated sensors is measured on its ability to record the highest peak voltage and the highest occurrence of PD from the PD pattern. Based on the discussed results earlier, the fabricated sensors are proven to be useful in detecting PD as similar as the MI. PZTs are fully able to detect PD too, however, the implementation of OFS in PD detection has canceled out the former sensors used in this experiment. Therefore, OFS has been identified to be more suitable sensor to be used in acoustic detection of partial discharges.

ACKNOWLEDGEMENT

Authors gratefully thank Universiti Teknologi Malaysia and Universitas Sriwijaya, Indonesia for financial support through research grants: 4B278, 4B279, 4B340, 4B342 and 13H98.

REFERENCES

- [1] J. B. Rosolem et al., "A fiber optic powered sensor designed for partial discharges monitoring on high voltage bushings," SBMO/IEEE MTT-S Int. Microw. Optoelectron. Conf., Porto de Galinhas, Brazil, pp 1-5, 2015.
- [2] S. Qian, H. Chen, Y. Xu, L. Zhong, A. S. Single, and M. Fiber, "Acoustic Fiber Optic Sensors for Partial Discharge Monitoring," 2016 IEEE Electrical Insulation Conference (EIC), pp. 19–22, 2016.
- [3] M. Lindgren and M. Kharezy, "Report on Fiberoptic sensors for high-voltage applications," pp. 1-13, 2015.
- [4] T. B. W. and D. Bayuwati, "An SMS (single mode – multi mode – single mode) fiber structure for vibration sensing," 2nd Int. Symp. Front. Appl. Phys. (ISFAP 2016), pp. 1-6, 2017.
- [5] A. Sun, Y. Semenova, G. Farrell, A novel highly sensitive optical fiber micro- phone based on single mode–multimode–single mode structure, *Microwave Opt. Technol. Lett.* Vol. 53, No. 2, pp. 442–445, 2011.
- [6] Q. Wu, Y. Semenova, P. Wang, et al., The use of a bent singlemode multimode–singlemode (SMS) fiber structure for vibration sensing, in: 21st International Conference on Optical Fibre Sensors (OFS21), International Society for Optics and Photonics, 2011, 77535G-77535G-4.
- [7] Deng, Jiangdong & Xiao, Hai & Huo, Wei & Luo, Ming & May, Russ & Wang, Anbo & Liu, Yilu. Optical fiber sensor-based detection of partial discharges in power transformers. *Optics and Laser Technology - OPT LASER TECHNOL.* Volume 33, Issue 5, July 2001, Pages 305-311.
- [8] M. A. Alsaedi, J. R. Rashed, A. M. Dakhil, and S. F. Atyah, "Localization of Acoustic Wave Using Leakage Current and Fiber Optic Sensor Techniques," International Conference on Chemistry, Biomedical and Environment Engineering (ICCBEE'14) Oct 7-8, 2014 Antalya (Turkey), pp. 7–10, 2014.