

Non-linear PID Controller for Trajectory Tracking of a Differential Drive Mobile Robot

Umar Zangina^{†,‡†}, Salinda Buyamin^{†*}, Mohamad Shukri Zainal Abidin[†], Mohd Saiful Azimi Mahmud[†], Hameedah Sahib Hasan^{†,‡†}

[†]School of Electrical Engineering, Faculty of Engineering, Universiti Teknologi Malaysia, 81310 UTM Skudai, Johor, Malaysia

[‡]Ministry of Higher Education and Scientific Research, Al Furat Al Awsat Technical University, Iraq.

^{‡†}Research Fellow 1 @ sokoto energy research centre Usmanu Danfodiyo University sokoto, Nigeria

*Corresponding author E-mail: salinda@fke.utm.my

ABSTRACT: The application of differential drive robots has grown from scientific research to broader industrial and commercial purposes. In order to Navigate the robot in difficult terrains, it must be well equipped with a robust controller with good path tracking ability and general stability. Typically, the wheeled mobile robot (WMR) can essentially be kinematically controlled by defining a route and determining the traveling time, speed and direction to get from one place to another. However, by ignoring the dynamic model of the robot, a purely kinematic model approach has been revealed to produce unrealistic results at higher speeds and loads. As a consequence, there are significant limitations to the applicability of solely kinematic systems to mobile robotics and hence, in recent years, there has been a trend towards the application of dynamic modelling. In this study, a simple but effective solution for the path tracking problem of a mobile robot using a PID controller is proposed. The method adopted is a trial and error technique with six tuning parameters for the robot to track a desired trajectory. The final mathematical derivation for a nonholonomic differential drive mobile robot was computationally simulated using MATLAB for both kinematic and dynamic models respectively. The controller was used to overcome the nonlinearity of the reference trajectory tracking as well as the speed of the DC motor adjustments. In order to evaluate the performance of the developed robot controller, tests were also carried out for different trajectories in terms of the initial and final conditions. The results show that the developed PID controller is responsive enough to be able to speed up when required to match the reference trajectory.

KEYWORDS: differential drive, trajectory tracking, mobile robot, PID controller and dynamic model.

INTRODUCTION

Mobile robots are robots that can move autonomously from one particular predefined location to another. They possess the exceptional features of stirring around without restrictions within a known workspace contrasting with the majority of industrial robots that can only move in a definite workspace [1]. This flexibility makes them more suitable for a considerably better performance in terms of applications in structured, semi-structured and unstructured environments. Differential drive wheeled mobile robot is the most commonly used mobile robot and it comprises of a robot platform having two fixed powered wheels attached to its left and right sides. Both wheels are independently driven and one or more passive castor wheels are used for stability and balancing [2]. The robot moves straightforward or backward if the wheels rotate at the same speed. It tracks a curved route along the arc of an instantaneous circle if one wheel is running faster than the other; and if the two wheels are rotating at equal speeds in opposite directions, the robot turns about the midpoint of the two driving wheels [2,3]. From the viewpoint of control design, an essential characteristic of mobile robots is the non-square proportions of the models. However, this makes the task of designing their controller simpler since they generally entertain only two variables (linear and angular speed) in modelling the movement while employing three variables to model their positions [4]. The position variables are the x and y coordinates on a plane and the angle the robot forms with the horizontal x axis. Therefore, there are fewer control variables than variables to be controlled [5]. The simplest and most fundamental control of a robot in an environment can be achieved with a point-to-point method (classic control), as the path of the states between the initial and final states are not critical. The second option is to control

the robot to guide it to abide by a reference trajectory from its start point to the ending, which renders it the most used approach because the environment typically presents obstacles. The closed loop control is always used because it is robust to the initial state's errors and other disturbances alongside the operation, which would not be achievable in an open loop system [6,7]. The major problem in the field of mobile robotic with nonholonomic restrictions is the path tracking control which primarily ensures that the robot adheres to its predefined trajectory autonomously [8].

LITERATURE REVIEW

The literatures have offered countless proposals for nonholonomic mobile robots path tracking (WMR) but the majority of them commonly employ the model based on the robot's kinematic equations namely, the kinematic model, owing to its simplicity. However, a model for motion generation of differential-drive mobile robots was introduced [9]. The model takes into account the robot's kinematic and dynamic constraints, making the velocities and accelerations confined and well-suited to those the robot can perform. However, the major contribution of the research work being the design of the motion controller itself and optimizing the system performance to meet the design requirements. In order to guide a differential drive mobile robot (unicycle-like mobile robot) through trajectory tracking in an adaptive controller was used [7]. Nonetheless, only the kinematic model of the robot was considered in generating the desired values of the linear and angular velocities at the initial stage.

Subsequently, the robot dynamics were compensated for, by processing such values and thereby, generating the commands for angular and linear velocities delivered to the robot actuators. In a similar manner, proposes a scheme of robust trajectory tracking for a nonholonomic differential drive wheeled mobile robot with parameter uncertainty, input constraints and peripheral disturbances [10]. In contrast with the aforementioned works, particularly in comparison with the tracking was achieved in the presence of kinematic and dynamic uncertainties [7,9]. These interact with disturbances that are dependent upon the sliding velocity which are generally considered to have unwarranted effects as regards to the performance of the trajectory tracking. This was achieved through, firstly, a feedback linearization based kinematic controller approach and then, a dynamic controller that is based on reference adaptive control. The disturbances in the robot model was remodeled as uncertain and a general LMI-based disturbance observer was then calculated to globally estimate them asymptotically. In a study, an adaptive robust controller based on structural information of the robot dynamics was proposed [11].

The odometric calculation of the robot's position with the wheels and actuator dynamics were also duly taken into consideration. In a similarly way, proposed a fuzzy-PID controller for path tracking with consideration to both dynamic and kinematic model [1]. The robust controller comprises of Fuzzy controller and a PID controller with two inputs and three outputs. This works in such a way that the controller tunes the parameters of the PID when the error rate drops to zero. An improved linear quadratic tracker is adopted to track a path in which was achieved using an enhanced reactive scheme that combines the dynamic flow with the Fuzzy logic to make the robots movement towards the target faster even in a complex environment [12]. The Fuzzy-logic can be used to dynamically regulate the weights but this is not always definite owing to the problem of selecting the appropriate weight. Taking into account both the dynamic model of the mechanical structure and the mathematical model of the actuators during the control design stage for the WMR which is very cumbersome, the task becomes more and more complex. However, it permits the design of a controller that resolves the trajectory tracking problem more efficiently which can be observed when the WMR is moving at high speeds or when its mass is variable [13].

RELATED LITERATURE

The simple adaptive control method for path tracking of nonholonomic mobile robots proposed in incorporates actuator dynamics with three-level controller that performs the trajectory tracking task [5]. They, however, consider the dynamics in relation to the three subsystems namely, the mechanical structure, the actuators, and the power stage. The low-level controller is related to two cascade controls based on sliding modes and PI control for the power stage while the medium level is based on two sensors less control. These are designed via differential flatness for the actuators and the high level corresponds to an input-output linearization control for the mechanical structure. Another three-level hierarchical controller designed is proposed which considers the mathematical model of the mechanical structure (differential drive WMR), actuators (DC motors), and power stage DC/DC Buck power converters [14].

A different approach proposed a PID and kinematic based back stepping controller (KBBC) for a differential drive mobile robot designed to be able to track a desired trajectory [15]. The KBBC and PID controllers were used to overcome the nonlinearity of the trajectory tracking and adjustment of the actuator speed. An observer-based trajectory tracking controller approach for the wheeled mobile robot (WMR) model is proposed In order to further simplify the design complexity, the dynamic surface control method was effectively and successfully exploited and proposed for tracking controller with special considerations to the dynamics of the actuator [16]. Likewise, in an innovative method of kinematic and dynamic modelling using a principle of virtual work is proposed [17]. The essence is to use the principle of virtual work in dynamic model equations to control the actuators torques to follow the desired trajectory during implementation of the mobile robot task. This approach complements existing work on dynamic modelling and trajectory tracking control of holonomic mobile robots.

Summarily, there are very few controllers which considered the comprehensive dynamic system as well as motors with actuators owing to the complexities in their design procedures [5,15-18]. However, the developed PID controller in this paper proposes a trial and error technique that tackles the problem of non-linearities in reference trajectory tracking. In addition, the designed control system offers high degree of freedom by maintaining six (6) control constants and consequently permits the optimization of the overall system performance of the robot. The PID controller here, not only considers the distance error to the target, but also develops a cruise or speed control. At the same time, the angular velocity and the angular error are being made the controllable parameters. Furthermore, by the technique presented here, a practical trial and error approach is developed to find six (6) constant values. In Section 2, the model transformation of the systems including the kinematics and dynamics of the mobile robot and the problem of designing controller based on the PID technique were discussed, and Section 3 deals with several results to show the effectiveness of the proposed method. Finally, some conclusions are drawn in Section 4

Kinematics of the Robot

In a two-wheel differential drive robot, angular and linear motion is implemented by two independent wheels. Pure angular motion is achieved when:

$$\theta_l = -\theta_r \tag{1}$$

Subscripts l and r refer to the two wheels (left and right), and θ is the rotation angle in the wheel. Pure linear motion is achieved when:

$$\theta_l = \theta_r \tag{2}$$

Motion of the robot is assumed to be in 2-D plane. In 2-D plane, robot's position is fully resolved when the following parameters are known: x and y: coordinates of the robot in the plane of motion.

φ angle between robot's x axis and y axis as seen in Figure 1.

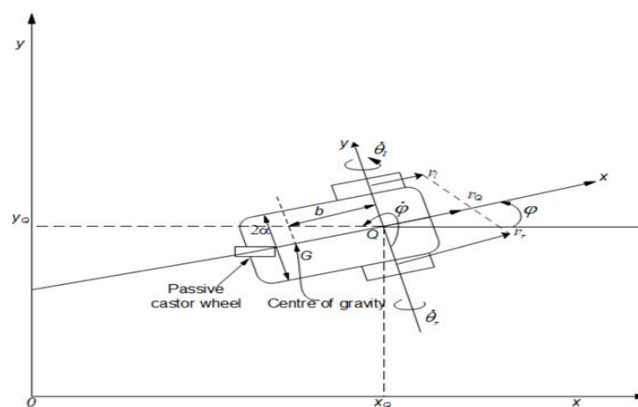

Figure 1. Differential drive mobile robot

In the above figure, α is the half distance between two wheels, and b is the distance between wheel's axis and the center of gravity. In robot kinematics, looking for the relationship between robot's local and global variables is

imperative. Considering the wheel's speeds, we have:

$$\dot{\varphi} = \frac{v_r - v_l}{\alpha} \quad (3)$$

$$v_Q = \frac{v_r + v_l}{2} \quad (4)$$

In the global coordinates:

$$\dot{x} = v_x = v_Q \cos(\varphi) \quad (5)$$

$$\dot{y} = v_y = v_Q \sin(\varphi) \quad (6)$$

However:

$$v_r = r\dot{\theta}_r \quad (7)$$

$$v_l = r\dot{\theta}_l \quad (8)$$

where r is the wheel's radius. Substituting equations 7 & 8 in 3 & 4 and then in 5 & 6, equation 9 is obtained in matrix form. This equation correlates coordinates derivatives to wheels rotation. Final equations in matrix form are [2,13,19]:

$$\dot{P} = \begin{bmatrix} \dot{x} \\ \dot{y} \\ \dot{\varphi} \end{bmatrix} = \frac{r}{2} \begin{bmatrix} \cos(\varphi) & \cos(\varphi) \\ \sin(\varphi) & \sin(\varphi) \\ \alpha & -\alpha \end{bmatrix} \begin{bmatrix} \dot{\theta}_r & \dot{\theta}_l \end{bmatrix} \quad (9)$$

These equations correlate two coordinates, global to local but does not provide any information about the forces and torques. Kinematics of the robot is helpful in the sense that, the angular velocities of the wheels are all known. The problem is, in many cases, torques are applied by electrical motors on the wheels and in fact the rotational speed is unknown. We need to solve robot's dynamics to obtain the kinematics of the robot. In the absence of internal frictions, slippage and steering, we assume that torque is inserted on the wheels by means of an electrical motor. Firstly, the forces on the robot's body need to be analyzed since the forces from the wheels act on the body and generate angular and linear acceleration.

$$I\ddot{\varphi} = 2\alpha(F_r - F_l) \quad (10)$$

$$m\ddot{v}_Q = \frac{F_r + F_l}{2} \quad (11)$$

However, force acting on the wheels are:

$$F_r = \frac{\tau_r}{r} \quad (12)$$

$$F_l = \frac{\tau_l}{r} \quad (13)$$

$$\ddot{\varphi} = 2\alpha \frac{\tau_r - \tau_l}{I r} \quad (14)$$

$$\ddot{v}_Q = \frac{\tau_r + \tau_l}{r m} \quad (15)$$

Using equations (10-15), the dynamics of the robot is resolved in matrix form as follows:

$$\begin{bmatrix} m & 0 \\ 0 & I \end{bmatrix} \begin{bmatrix} \dot{v}_Q \\ \dot{\varphi} \end{bmatrix} = \frac{1}{r} \begin{bmatrix} 1 & 1 \\ 2\alpha & -2\alpha \end{bmatrix} \begin{bmatrix} \tau_r \\ \tau_l \end{bmatrix} \quad (16)$$

The above equations suggest that we may introduce two variables:

$$u_1 = \tau_r - \tau_l \quad \& \quad u_2 = \tau_r + \tau_l$$

Then rewriting the above equations in form of:

$$\begin{bmatrix} m & 0 \\ 0 & I \end{bmatrix} \begin{bmatrix} \dot{v}_Q \\ \dot{\varphi} \end{bmatrix} = \frac{1}{r} \begin{bmatrix} 1 & 0 \\ 0 & 2\alpha \end{bmatrix} \begin{bmatrix} u_1 \\ u_2 \end{bmatrix} \quad (17)$$

The benefit of this new definition is that angular and linear accelerations are now independently correlated to u_1 and u_2

Motor Model

DC motor model developed here is as shown in Figure 2.

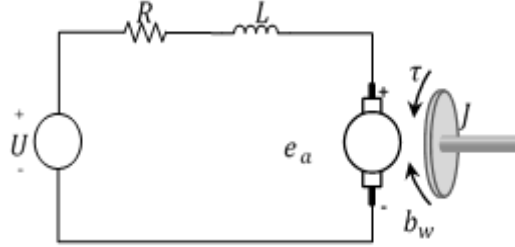

Figure 2. DC motor schematic representation

$$T = NK_t i(t) \tag{18}$$

$$V(t) = R_a i(t) + L_a \frac{d}{dt} i(t) + e_a \tag{19}$$

$$e_a = K_b \omega_{wheel} \tag{20}$$

where e_a is the emf voltage of the motor, $V(t)$ is the motor voltage, $i(t)$ is motor current and R_a ohmic resistance of the motor, L_a motor inductance and ω_{wheel} is the wheels angular velocity which is calculated from angular and linear velocity of the robot. K_b and K_t are motor constants. Figure 3 Shows the control block diagram start from trajectory coordinates till the robot coordinate.

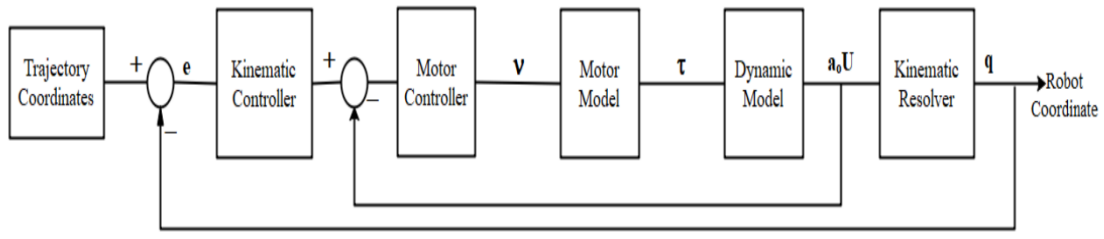

Figure 3. Control block diagram

The robot and the DC motor characteristics are as in Table 1.

Table 1: Robot and DC motor parameters

ROBOT			DC – MOTOR		
TERM	UNIT	VALUE	TERM	UNIT	VALUE
m	kg	27	$V(t)$	V	12
m_w	kg	0.5	$i(t)$	A	2.85
I_d	kg*m ²	0.732	R_a	Ω	1.01
I_w	kg*m ²	0.0025	L_a	H=V*s/A	0.088*10 ⁻²
I_m	kg*m ²	0.0012	K_b	V*s	12.939*10 ⁻²
d	m	0.05	K_t	N*m/A	12.939*10 ⁻²
R	m	0.0975	τ	N*m/A	0.1537
L	m	0.164	$i(t)$	A	11.8
N	-	53	$\omega(t)$	rpm	6640

Developing the Feedback Control System

The Main target of the control system is, to move the robot from point A to point B by applying a suitable and adequate torque as shown in Figure (4).

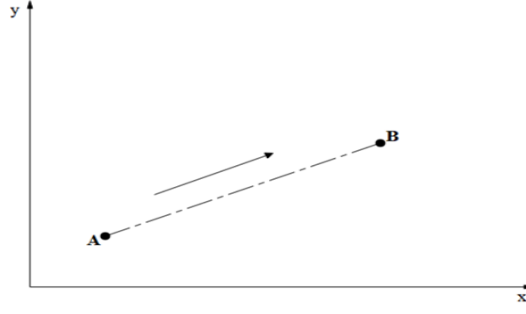

Figure 4. Control system's target

PID controllers can be used for such problems but adopting a suitable control function (error function) is to find out an appropriate function, we refer to physics of the robot motion. Assuming, the robot is at a location A with global coordinate vector of P_0 . Then the target point is at X_t and Y_t . Let's assume that the control target is: Robot must achieve the target position; however, the final angle is not important which means φ_t can be any value. To achieve this control goal, the process is divided into two steps. Firstly, robot corrects its direction and faces the target. Secondly, the robot starts moving towards the target. By the mentioned sequence, a robust, fast and accurate position control can be achieved with proper oscillations in angle (direction). Implying that, the technique above needs a lag. Since rotational and linear motions are decoupled in the control system, this approach can be suggested by controlling U_1 and U_2 . System model presented here is the dynamic model of the system. If U_1 and U_2 are inputs, then we can write P (robot position vector) as follows:

$$x(t) = \int v(t) \cos(\varphi(t)) dt = \int \cos(\varphi(t)) \left(\int \frac{u_1 + u_2}{rm} dt \right) dt \quad (21)$$

$$y(t) = \int v(t) \sin(\varphi(t)) dt = \int \sin(\varphi(t)) \left(\int \frac{u_1 + u_2}{rm} dt \right) dt \quad (22)$$

$$\varphi(t) = \int \left(\int 2\alpha \frac{u_1 - u_2}{Ir} dt \right) dt \quad (23)$$

in terms of state space:

$$\dot{x} = v \cos \varphi$$

$$\dot{y} = v \sin \varphi$$

$$\dot{\varphi} = \omega$$

$$\dot{v} = \frac{u_1}{rm}$$

$$\dot{\omega} = 2\alpha \frac{u_2}{Ir}$$

$$\dot{\mathbf{X}} = \mathbf{A}\mathbf{X} + \mathbf{B}\mathbf{U}$$

$$\mathbf{Y} = \mathbf{C}\mathbf{X} + \mathbf{D}\mathbf{U}$$

Above set of equations defines the system's state space. Therefore, the system can be represented in matrix form as:

$$\mathbf{A} = \begin{bmatrix} 0 & 0 & 0 & \cos(\varphi) & 0 \\ 0 & 0 & 0 & \sin(\varphi) & 0 \\ 0 & 0 & 0 & 0 & 1 \\ 0 & 0 & 0 & 0 & 0 \\ 0 & 0 & 0 & 0 & 0 \end{bmatrix} \quad \mathbf{B} = \begin{bmatrix} 0 & 0 \\ 0 & 0 \\ 0 & 0 \\ \frac{1}{rm} & 0 \\ 0 & \frac{2\alpha}{Ir} \end{bmatrix} \quad \mathbf{C} = \begin{bmatrix} 1 & 0 \\ 0 & 1 \\ 0 & 0 \\ 0 & 0 \\ 0 & 0 \end{bmatrix} \quad \mathbf{D} = \mathbf{0} \quad (24)$$

Developing the Control Strategy

From Figure 5, there are three main feedback loops. Two for x and y and one for angle (φ). The main target for the angle is to keep the direction towards the target or:

$$\varphi_T = \text{atan}\left(\frac{\Delta y}{\Delta x}\right) \quad (25)$$

$$\Delta y = y_T - y = \text{err}(y)$$

$$\Delta x = x_T - x = \text{err}(x)$$

In developing the control signal, we need physically meaningful signal. Since u_1 and u_2 are torques. Using a proportional derivative, error signals will be a composition of position and velocities. So, signal will be zero when both position error and velocity are zero.

For:

$$\text{err}_1(x) = (KP_x \text{err}(x) + KD_x \dot{\text{err}}(x)) \cos \varphi \quad (26)$$

For y:

$$\text{err}_1(y) = (KP_y \text{err}(y) + KD_y \dot{\text{err}}(y)) \sin \varphi \quad (27)$$

Sum:

$$\text{err}_1 = \text{err}_1(x) + \text{err}_1(y) \quad (28)$$

For φ :

$$\text{err}(\varphi) = \varphi_T - \varphi \quad (29)$$

$$\text{err}_1(\varphi) = (KP_{1\varphi} \text{err}(\varphi) + KD_{1\varphi} \dot{\text{err}}(\varphi)) \quad (30)$$

For the angle, we have a signal which is a combination of angular velocity and the angular error itself. That means the controller tends to control the angular acceleration which results in higher stability and lower oscillations in the direction. The produced error signals are u_1 and u_2 . Since, control signals go to different motors, we need to decompose the signals to torques. After that for each torque, a PI controller is used. So, the final torques input to the system corresponding to the error signals are:

$$Er_1 = \text{err}_1 + \text{err}_1(\varphi) \quad (31)$$

$$Er_2 = \text{err}_1 - \text{err}_1(\varphi) \quad (32)$$

$$V_r = KP_r Er_1 + KI_r \int Er_1 dt \quad (33)$$

$$V_l = KP_l Er_2 + KI_l \int Er_2 dt \quad (34)$$

Voltage Limiters

Since motor voltage is limited, a limiter is considered in the simulation. When the voltage is higher than maximum allowable value for the motors, a limit is set as assigned maximum voltage. This is represented by a saturation function in the model, typically, 12 V. The equation describing the voltage limiter is:

$$V_r = \text{sign}(V_r) \times \min(|V_r|, 12) \quad (35)$$

Dynamic model of the system

The final set of equations are:

$$V_r = KP_r \text{Err}_1 + KI_r Y(6) \quad (36)$$

$$V_l = KP_l \text{Err}_2 + KI_l Y(7) \quad (37)$$

$$\tau_r = f_r(V_r, Y(4), Y(5)) \quad (38)$$

$$\tau_l = f_l(V_l, Y(4), Y(5)) \quad (39)$$

$$\dot{Y}(1) = Y(4) \cos(Y(3)) \quad (40)$$

$$\dot{Y}(2) = Y(4) \sin(Y(3)) \quad (41)$$

$$\dot{Y}(3) = Y(5) \quad (42)$$

$$\dot{Y}(4) = \frac{\tau_r + \tau_l}{mr} \quad (43)$$

$$\dot{Y}(5) = 2a \frac{\tau_r - \tau_l}{lr} \quad (44)$$

$$\dot{Y}(6) = \text{Err}_1 \quad (45)$$

$$\dot{Y}(7) = \text{Err}_2 \quad (46)$$

In the Equations (40-45), Y (1) is x coordinate, Y (2) is the y coordinate, Y (3) is the angle, Y (4) is the velocity v and Y (5) is the angular velocity. Substituting Equations (25) to (29) for error values, the following functions are obtained:

$$\text{Err}_{(2,1)} = K_1(e_r \cos(e_\varphi) \mp K_2 e_\varphi) + K_3 \frac{d}{dt}((e_r \cos(e_\varphi) \mp K_4 e_\varphi)) \quad (47)$$

$$e_r = \text{sqrt}(\text{err}_1(x) + \text{err}_2(y)) \quad (48)$$

$$e_\varphi = \text{err}(\varphi) \quad (49)$$

$$K_1 = KP_x = KP_y, K_2 = \frac{KP_\varphi}{K_1}, K_3 = KD_x = KD_y, K_4 = \frac{KD_\varphi}{K_3}$$

In designing the error function, the distance error is multiplied by cosine of the angle error. This provides a priority to direction rather than distance error particularly when the direction error is too high (especially at thresholds or trajectory sudden change in direction). The benefit is fast stabilization of the robot which reacts to changes in the trajectory directions speedily and accurately. The error function in Equation (46) has the ability to:

1. Control both velocity and location error.
2. Adjust the speed of the robot via adjusting the position of each error term by choosing appropriate K_1 and K_2 ratios.

An approach to stabilizing and finding appropriate K values is hereby presented. To find out K values, a practical method is used as follows in an iterative manner:

1. Stabilize inner motor controller. Develop a controller for wheel speed control. If the system is linear, one may use PID control design for linear system.
2. Consider only distance error that gives only a straight line in x direction. The speed of the target is 0.1 maximum speed of the robot. Then, find the K_1 value.
3. Consider only the distance error when the target moves by 0.9 maximum of the robot speed. Find K_3 to have a first order response (minimize overshoot and oscillation).
4. Now consider a straight line with a constant angle for target movement. Find appropriate K_2 .
5. Consider a path with constant angular velocity of 0.9 maximum angular velocity of robot. Find the appropriate K_4 to have minimum overshoot and oscillations in angle.
6. Give a sinusoidal path as target with maximum speed of 0.9 robot speed. Adjust the parameters if necessary, to have a smooth function.

The above method is implemented and the best values for the coefficients K_1 , K_2 , K_3 , and K_4 are found to be 0.03,

6, 10 and 0.1 respectively. It is worthy of note that an important requirement for the above error function is for the error to reduce with time. This is only applicable if the maximum robot velocity is higher than the trajectory velocity. The above models and methods are implemented in MATLAB/SIMULINK software. The Simulink diagram shown in Figures 5, 6 and 7 demonstrate the main SIMULINK block for the model, the subsystem and the motor subsystem respectively

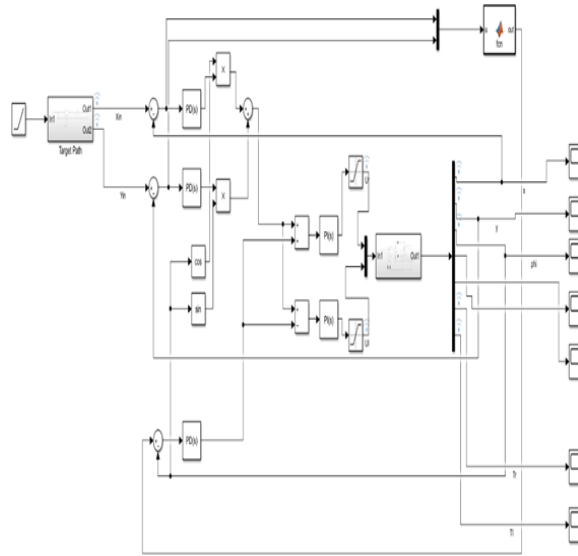

Figure 5. Simulink model for robot system and controller

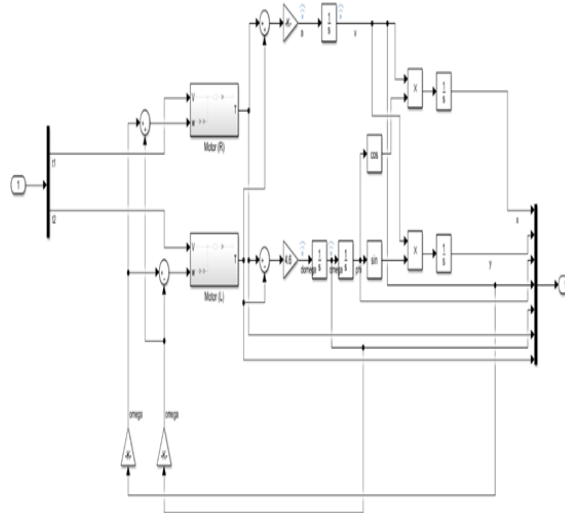

Figure 6. Simulink Model of the subsystem.

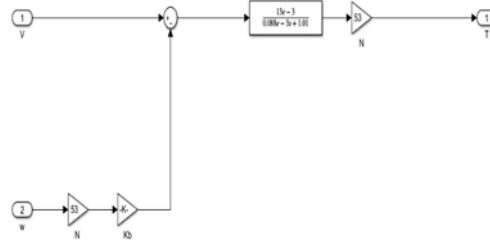

Figure 7. Simulink model of motor subsystem

RESULTS

In order to control a robot to track a moving target (a target robot), three different paths are considered for the target: a stationary target, a sinusoidal and a scattered path made of different line sections. Assume the target is at location (5,5) and the robot is at location (0,0) with 00 robot angle. Any distance less than the threshold of 0.01 m implies that the target has been tracked by the robot. As shown in Figure 8, the target is at a fixed location while the robot approaches it through the given path and the angle smoothly changes through the path. The controller maintained a linear path to the target despite the initial angular mismatch. The corresponding velocity related to the above path is plotted in Figure 9. The figure demonstrated how the velocity rises gradually to a peak at 2.5 m/s and then sharply falls with time. In fact, the robot tracks the target within an approximate 13 second. Eventually, as the velocity also decays to zero, error signal automatically becomes zero since the velocity component itself is a part of the error signal.

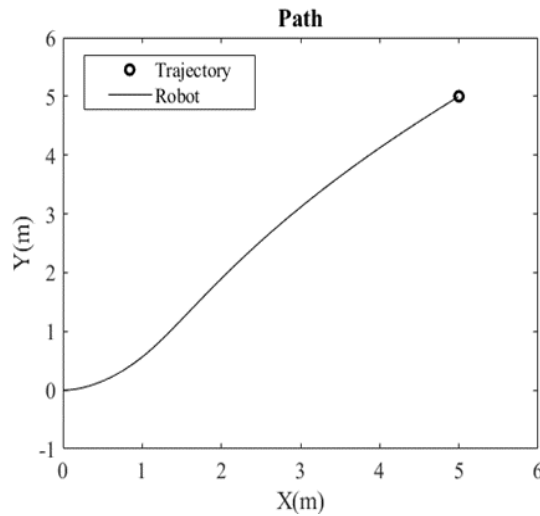

Figure 8. Robot tracking trajectory for fixed target.

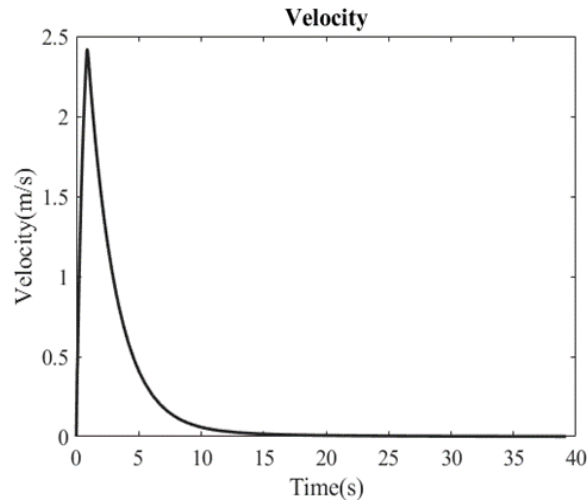

Figure 9. Linear velocity of tracking robot for stationary target.

The torque actions for the motor are presented in 8 and 9. The highest torque of 8 Nm occurred at time 0 sec which gradually falls with time as the separation between the target and the robot approaches zero as demonstrated in Figure 10. The sharp drop in the left motor torque produces a torque difference between the left and right motors which performs the correction of the path angle. It is also demonstrated that the rise in the voltage to a maximum in the right motor produces an angle correcting torque difference and both voltages subsequently dropped to zero. The motor torque and the voltage responses were plotted for the initial two seconds in order to best demonstrate how the changes in torque is tracked by the motor voltage.

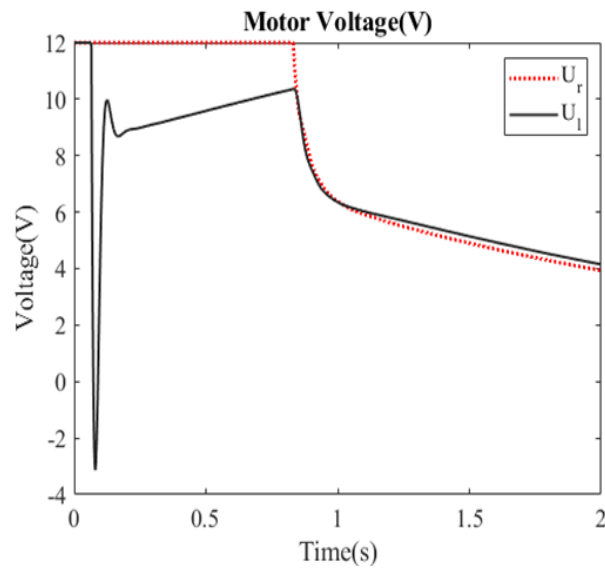

Figure 10. Right and Left motor torque.

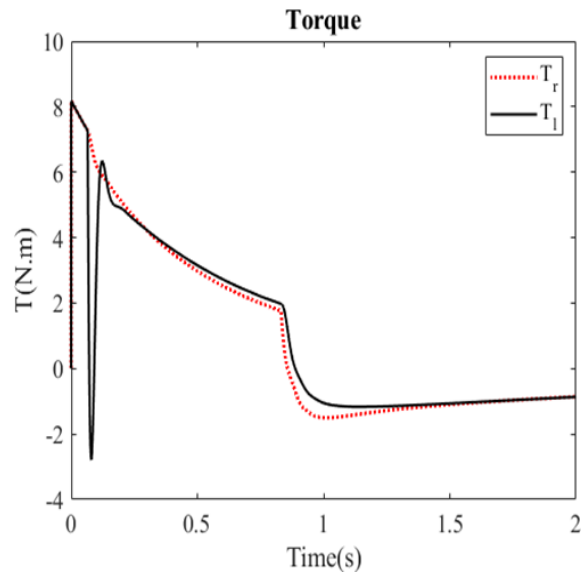

Figure 11. Right and left motor voltage

In resonance to the trajectory of the robot path, the angular velocity reaches a maximum value of 1.2 rad/sec, sharply drops to negative values and then back to zero as demonstrated in Figure 11. It can also be observed that the correction of the angle is performed continuously, but however, it occurred in two different time intervals, viz: (0.1s to 0.3s) and then (0.7s to 0.9s). This graph matches the angle variations shown in Figure 12 while the overshoot response in the plot of Figure 9 for the robot angle corresponds with the plot of Figure 11 for the robot torque. While Figure 13 shows tracking robot angle.

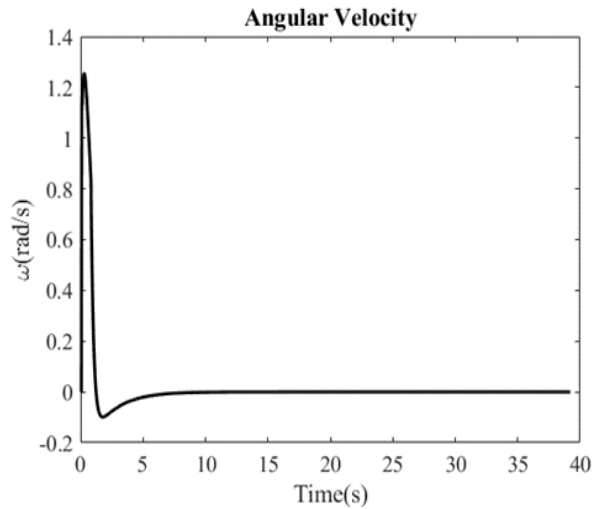

Figure 12. Angular velocity of follower robot

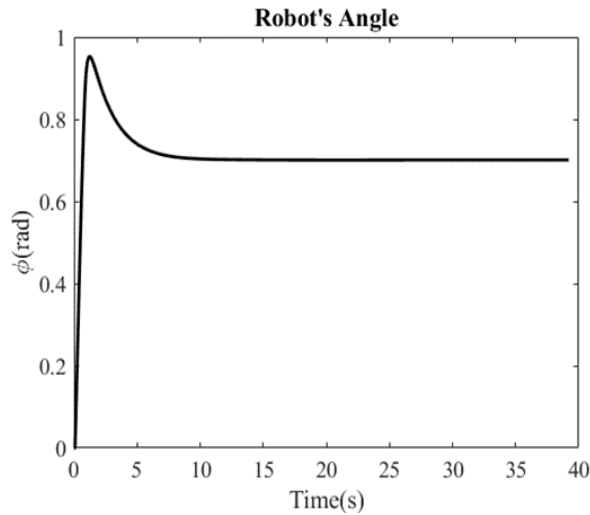

Figure13. Tracking robot angle

It is important not only for a controller to be able to follow a prescribed trajectory, but its performance has to have the anticipated level of accuracy within the acceptable limits. In order to verify the tracking capabilities of the PID controller, further simulations were conducted to simulate trajectories such as the range of speeds. For these tests, the gain settings of the PID controller are tuned to attain higher precision than the previous simulations so as to ensure that maximum performance is attained and that errors due to sloppy tuning are minimized. Figure 14 represent the dynamic behavior of the robot when the target moves oscillatory on a *sine* trajectory of the form of Equation (49). Thus:

$$Y(t) = 5 \times \sin \left(0.2\pi t + \frac{\pi}{4} \right) \tag{50}$$

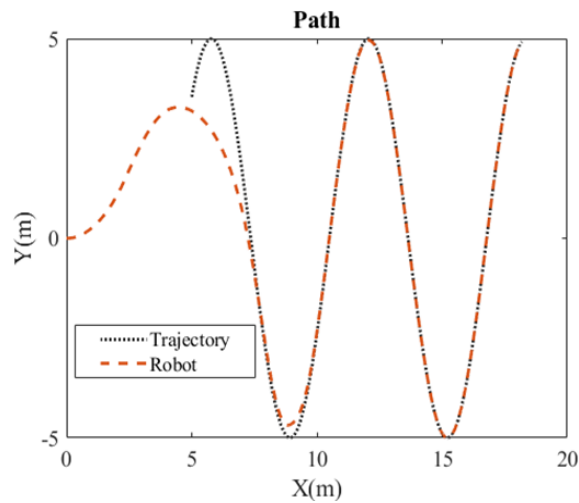

Figure 14. Robot tracking trajectory for sinusoidal path.

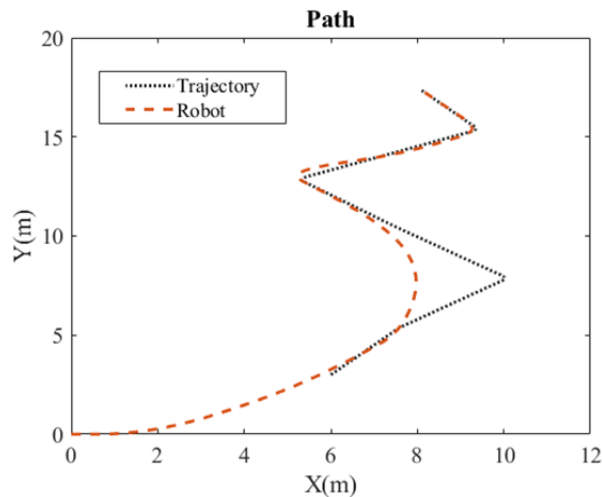

Figure 15. Robot tracking trajectory for Zigzag pat

The zigzag path is shown in Figure 15. The graph shows target is moving on a stochastic path which consists of line sections. The robot starts from the (0,0) at angle of 0^0 enabling the robot to track the target.

CONCLUSION

The developed PID controller is capable of tracking a moving target with high accuracy and speed considering different path trajectories which have been analyzed to prove this capability. In addition, since the velocity is included in the error signal, the robot velocity reaches zero when the target robot is fixed which also makes the controller suitable for fixed target locations. The controller is designed to prioritize the angular error over position error. The reason being that, angular errors results in large position errors which increases over time. This concept leads to path tracking with high accuracy as presented. Moreover, this design is very satisfying for fix targets since for fixed targets, the best path is the linear path between two points. By prioritizing the angular error over the position error, the resultant path follows a straight path between two points irrespective of the initial robot angle.

ACKNOWLEDGEMENTS

The authors are grateful to the Universiti Teknologi Malaysia and the Ministry of Higher Education (MOHE), for their partial financial support through their research funds, Vote No. R.J130000.7351.4B428

REFERENCES

- [1] P.N. Chandra and S.J. Mija, "Robust controller for trajectory tracking of a Mobile Robot", in 1st IEEE International Conference on Power Electronics, Intelligent Control and Energy Systems, ICPEICES 2016, 2017.
- [2] B. Diriba, H. Prof, and W. Zhongmin, "Design and Control for Differential Drive Mobile Robot", International Journal of Engineering Research & Technology (IJERT), Vol. 6, No. 10, Pp. 327–335, 2017.
- [3] S. Lens and B. Boigelot, "Efficient Path Interpolation and Speed Profile Computation for Nonholonomic Mobile Robots", arXiv:1508.02608v1 [cs.RO] 11 Aug 2015 IMontefiore Institute, B28, University of Liege, B-4000 Liege, Belgium, 2015.
- [4] R.P.M. Chan, K.A. Stol, and C.R. Halkyard, "Review of modelling and control of two-wheeled robots", Annual Reviews in Control, Vol. 37, No. 1. Pp. 89–103, 2013.
- [5] R.S. Ortigoza, J.R.G. Sanchez, V.M.H. Guzman, C.M. Sanchez, and M.M. Aranda, "Trajectory Tracking Control for a Differential Drive Wheeled Mobile Robot Considering the Dynamics Related to the Actuators and Power Stage", IEEE Lat. Am. Trans., Vol. 14, No. 2, Pp. 657–664, 2016.

- [6] A.A. Al-Saffar, A.A. Diwan, L.S. Al-Ansari, and A. Alkhatat, “Experimental and artificial neural network modeling of natural frequency of stepped cantilever shaft”, *Journal of Mechanical Engineering Research Development*, Vol. 43, No. 4, Pp. 299–309, 2020.
- [7] J. Taheri-Kalani and M.J. Khosrowjerdi, “Adaptive trajectory tracking control of wheeled mobile robots with disturbance observer”, *International Journal of adaptive Control Signal Process.*, Vol. 28, No. 1, Pp. 14–27, 2014.
- [8] S.G. Tzafestas, K.M. Deliparaschos, and G.P. Moustiris, “Fuzzy logic path tracking control for autonomous non-holonomic mobile robots: Design of System on a Chip”, *Robot. Automation. System*, Vol. 58, No. 8, Pp. 1017–1027, 2010.
- [9] F.A. Salem, “Dynamic and Kinematic Models and Control for Differential Drive Mobile Robots”, *International Journal of Current Engineering and Technology*, Vol. 3, No. 2., 2013.
- [10] X. Gao, “Review of wheeled mobile robots’ navigation problems and application prospects in agriculture”, *IEEE Access*, vol. 6. Institute of Electrical and Electronics Engineers Inc., Pp. 49248–49268, 2018.
- [11] Z.G. Hou, A.M. Zou, L. Cheng, and M. Tan, “Adaptive control of an electrically driven nonholonomic mobile robot via backstepping and fuzzy approach”, *IEEE Trans. Control System Technology*, Vol. 17, No. 4, Pp. 803–815, 2009.
- [12] M. Asif, M.J. Khan, and N. Cai, “Adaptive sliding mode dynamic controller with integrator in the loop for nonholonomic wheeled mobile robot trajectory tracking”, *International Journal of Control*, Vol. 87, No. 5, Pp. 964–975, 2014.
- [13] M.N. Ismael, “Continuous Stirred Tank Reactor (CSTR) using Mamandi fuzzy control”, Vol. 43, No. 4, Pp. 348–359, 2020.
- [14] K. Akka and F. Khaber, “Optimal tracking control of a trajectory planned via fuzzy reactive approach for an autonomous mobile robot”, *Int. J. Adv. Robot. Syst.*, Vol. 15, No. 1, 2018.
- [15] M. Kalyoncu and F. Demirbaş, “Differential Drive Mobile Robot Trajectory Tracking With Using Pid and Kinematic Based Backstepping Controller”, *Selcuk University Journal of Engineering and Science Technology*, Vol. 5, No. 1, Pp. 1–15, 2017.
- [16] Y. Wang and Y. Wu, “Robust tracking control of uncertain nonholonomic wheeled mobile robot incorporating the actuator dynamics”, in *Chinese Control Conference, CCC*, Pp. 2392–2397, 2019.
- [17] H.M. Alwan, “Dynamic Analysis Modeling of a Holonomic Wheeled Mobile Robot with Mecanum Wheels Using Virtual Work Method”, *Journal Mechanical Engineering Research and Development*, Vol. 43, No. 6, Pp. 373–380, 2020.
- [18] J.R. García-Sánchez, “Tracking control for mobile robots considering the dynamics of all their subsystems: Experimental implementation”, *Complexity*, 2017.
- [19] T.S. Nguyen, Q.K. Bui, and T.K. Nguyen, “The software tuning the controller parameters of control system in thermal power plants”, *Journal of Mechanical Engineering Research and Development*, Vol. 43, No. 4, Pp. 245–255, 2020.