

PAPER • OPEN ACCESS

Development of rogowski coil sensor for partial discharge detection

To cite this article: E P Waldi *et al* 2019 *IOP Conf. Ser.: Mater. Sci. Eng.* **602** 012031

View the [article online](#) for updates and enhancements.



240th ECS Meeting ORLANDO, FL

Orange County Convention Center Oct 10-14, 2021



Abstract submission due: April 9

SUBMIT NOW

Development of rogowski coil sensor for partial discharge detection

E P Waldi¹, A Y Frenzi¹, R Fernandez¹, Darmawan¹, Darwison¹, H D Laksono¹, Aulia¹, A Hazmi¹, A Andre¹, H Abra², S Arief³, Z Nawawi⁴, M H Ahmad⁵, and N Hozumi⁶

¹Electrical Engineering Department, Universitas Andalas, Padang, Indonesia

²Mechanical Engineering Department, Universitas Andalas, Padang, Indonesia

³Chemical Science Department, Universitas Andalas, Padang, Indonesia

⁴Electrical Engineering Department, Sriwijaya University, UNSRI, Indonesia Institute of High

⁵Voltage and High Current, Faculty of Electrical Engineering, UTM, Johor Bahru, Johor, Malaysia.

⁶Electrical and Electronic Information Engineering, Toyohashi University of Technology, TUT, 1-1 Hibarioka, Tempaku-cho, Toyohashi, Japan

E-mail: ekawaldi@eng.unand.ac.id

Abstract. This paper presents the development of Rogowski coil to detect the partial discharge. Rogowski coil sensor is composed of a ferrite core with a various number of turns which is 5, 10, 20 and 30 turns with a half circle and full circle configuration. The sensors need to be tested based on the number of the turns they have in reading the partial discharge signals. The sensor is connected to a digital measurement device such as a digital oscilloscope which has an input impedance of 50 ohms and 1 Mohm with a time frame duration greater than or equal to 20 ms. The reading comparison is not only between the proposed sensors but also with a commercial partial discharge sensor. The partial discharge signal is generated by a commercial charge calibrator. The measurement result shows that using low impedance lead to decreased noise but the reading is too small compared with using high impedance.

1. Introduction

Rogowski coil (RC) sensor has a multi-feature in frequency response. It can detect a broadband signal although it detects a pattern of current flowing through a conductor, the output results in the form of the voltage signal that read by a measurement tool such as a digital oscilloscope. Partial discharge (PD) signal is a wave that has a low amplitude, and high frequency occurred in random and repeatedly. The signal can be detected by an RC sensor or an inductive sensor with some different methods. These measurements have been used in [1]–[7].

The conventional partial discharge measurement is using an impedance (Coupling quadrupole, Cq) to evaluate the quality of isolation in high voltage equipment or even used to detect phenomena in various conditions which are electrically varied such as source frequency, waveform, isolation condition, and environmental condition.



This sensor works in low voltage. If it is applied in high voltage measurement, it will need a voltage divider like a coupling capacitor (CC). Therefore the high voltage will be in the coupling capacitor, and the low voltage will be in the Ck. In this condition, the capacitor has a higher capacitance when the high voltage has low frequency, and conversely, the capacitor has a lower capacitance when the high voltage has a high frequency[8]. It will be challenging when applied to measure high voltage with high frequency. This situation will lead to an inapplicable power dividing, i.e., a voltage in sensor terminal will rise causing damage in low voltage equipment. The Rogowski coil sensor applies to solve the problem since the sensor only detects inductive currents.

This research develops a simple, low-cost Rogowski coil that can work with an acquisition tool such as a digital oscilloscope. Partial discharge signals that produced from a PD simulator will be detected by the sensors. The sensors have a different number of turns, and the measurement result will be read in Oscilloscope with different impedance value set. To check the accuracy of the sensor, the result will be linearized with an input value of the PD simulator and compared with the reading from the commercial PD detector.

2. Methodology

2.1. Experimental Set Up

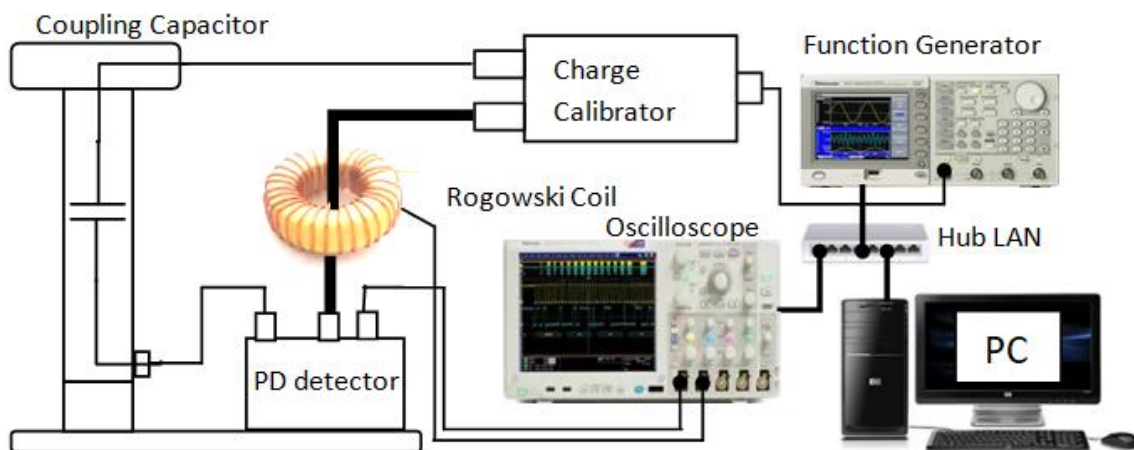
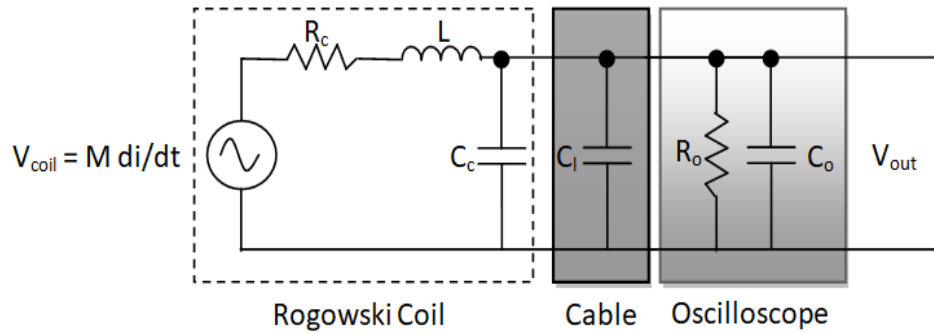

Figure 1. Experimental setup

The performance of the RC sensor will be tested by comparing the obtained result with a result from a commercial PD detector as shown in figure 1. Partial discharge signal is generated by a Charge Calibrator (CCal) where the output is a function of an input produced by a function generator (Fg). The Fg output is set to generate a right triangle form voltage with a magnitude of 5 volts and a frequency of 1 kHz. The output is connected to CCal input which has a capacitance of 141 pF. The charge of 705 pC in C_{cal} is produced from a multiplication of 141 pf in CCal with a voltage of Fg. Since the output response is in voltage, then only the magnitude of voltage is displayed.

The sampling rate in a digital oscilloscope (DO) is set in 200 MS/s with a sampling point of 4 Mpoint which equals to 1 sine wave with a frequency of 50 Hz. There are two type of input impedance used which are the 50-ohm resistor only and a parallel between a capacitor of 13 pF and a resistor of 1 Mohm that already installed in the oscilloscope. The RC sensor is connected to DO using a 10-m length coaxial cable. A PC with Labview program is used to control Fg and DO through a LAN cable.

2.2. The equivalent circuit of Rogowski Coil and oscilloscope



a. Equivalent circuit with the input impedance of 1 Mohm and 13 pF in Oscilloscope.

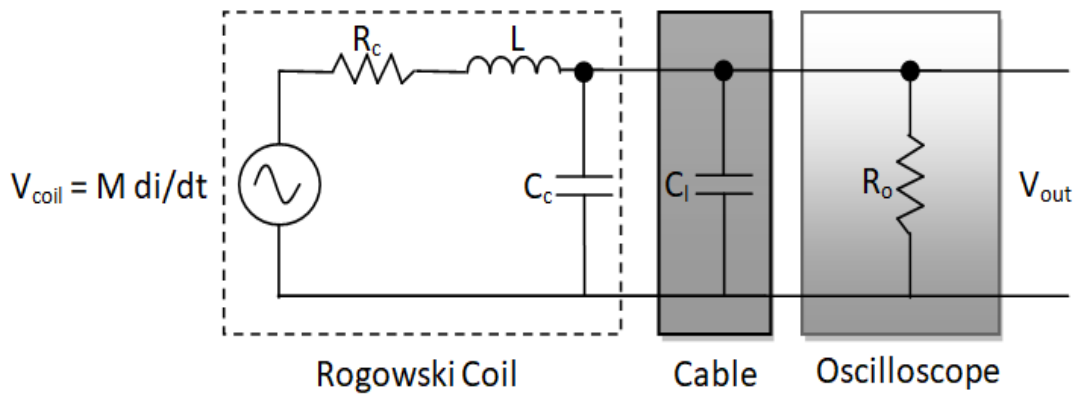

b. Equivalent circuit with the input impedance of 50 ohms in Oscilloscope.

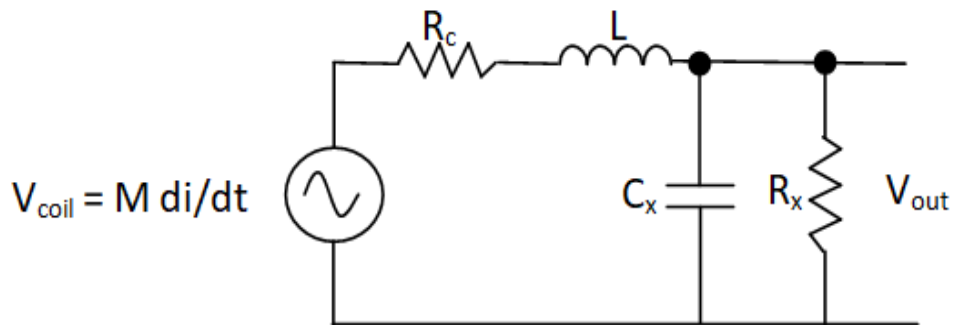

c. The common equivalent circuit for a figure a and b.

Figure 2. The equivalent circuit of the partial discharge sensor measurement system.

RC model [6] is connected to DO which has 2 type of impedance circuit using a coaxial cable [9]. The first type is an input impedance of parallel circuit which consists of a capacitor (C_o) and a resistor (R_o) as shown in figure 2.a. The second is an input impedance which only consists of a resistor (R_o) with the resistance of 50 ohms as shown in figure 2.b. By applying of electrical circuit theorems about parallel resistor and a parallel capacitor, figure 2.a and 2.b can be simplified as in figure 2.c.

3. Result and Discussion

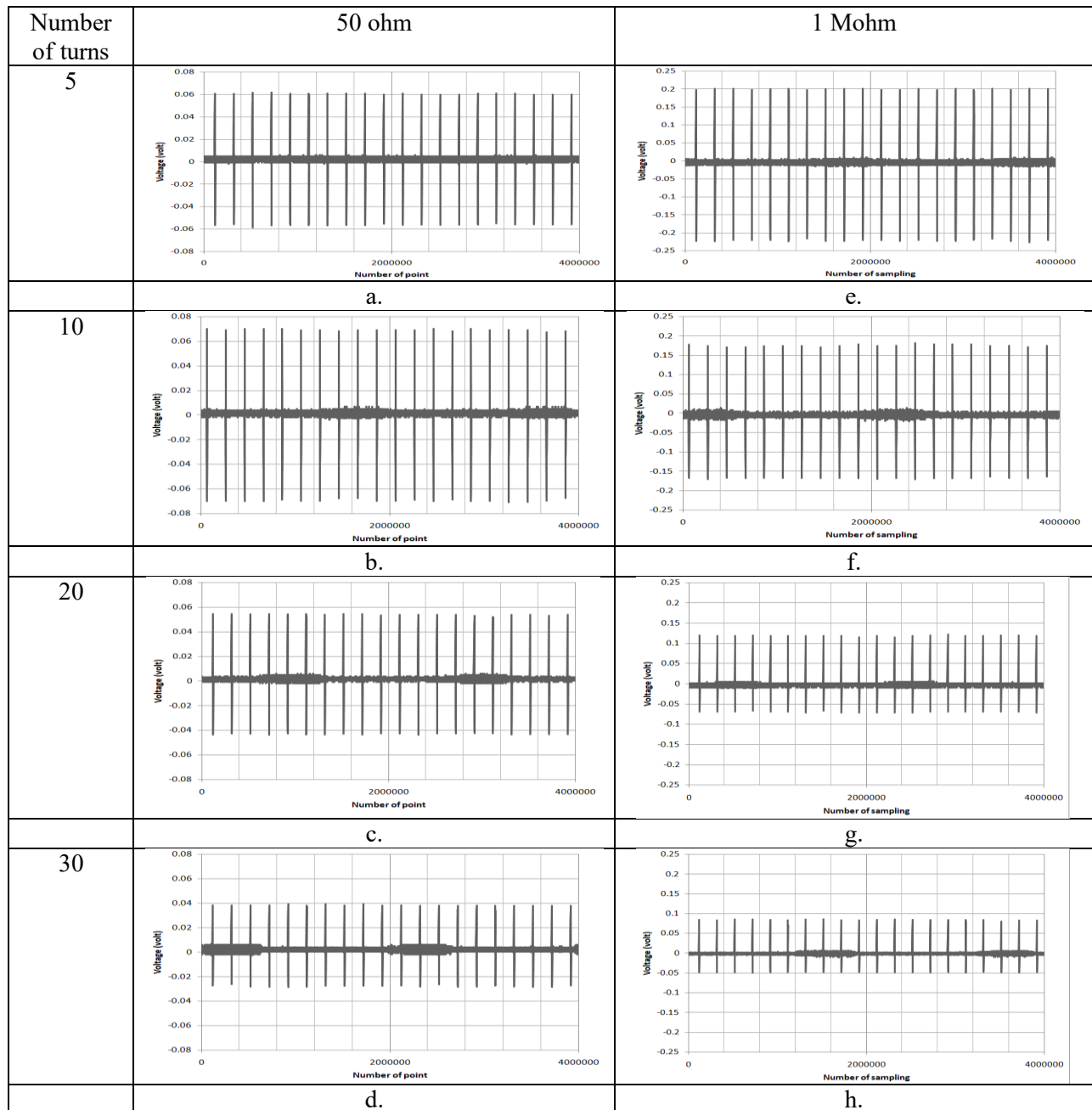

Figure 3. The measurement result of input impedance effect with some turns

Based on the transfer function, the obtained magnitude of voltage depends on the given input impedance[10]. Figure 3 shows that a low input impedance results in a small value in reading. Then reading in magnitude will decrease if the inductance increases by adding more number of turns. The noise rises when some turn increases.

No. turn	50 ohm	1 Mohm
5		
10	<p style="text-align: center;">a.</p>	<p style="text-align: center;">e.</p>
20	<p style="text-align: center;">b.</p>	<p style="text-align: center;">f.</p>
30	<p style="text-align: center;">c.</p>	<p style="text-align: center;">g.</p>

	d.	h.
--	----	----

Figure 4. Waveforms that produced from the sensor with the variation of input impedance and number of turns.

Figure 4 shows a different form of the wave on input impedance with a variation of some turns. As explained above that maximum reading will be small for low impedance. In this figure, it emphasizes some oscillation and frequency resulted from the increasing number of turns of the RC sensor.

In RC sensor with five turns shows that some oscillation when using input impedance of 50 ohms is smaller than when using input impedance of 1 Mohm. On Impedance of 50 ohms with an increasing number of turns, the amount of oscillations is relatively the same as on impedance 1 Mohm but the period of the first wave increases as the number of turns increases.

In RC sensor with an impedance of 1 Mohm, the number of oscillation decreases when adding ten turns more in the number of turns, but no changed when adding 20 turns more or even 30 turns more. The period of the first wave increases more as the number of turns increased.

4. Conclusion

Some turns and the value of input impedance of oscilloscope determine the reading of the peak values of partial discharge signals by RC sensor. The highest value of input Impedance (1 Mohm) in oscilloscope producing a high number of oscillation that can be decreased by adding the number of turns. However, adding some turns for the input impedance of 50 ohm doesn't change the number of oscillation. These additions of some turns for both input impedance values increase the period of the first oscillation wave.

References

- [1] B Paophan, A Kunakorn, and P Yutthagowith 2016 Implementation of A Rogowski ' s Coil for Partial Discharge Detection *Electr. Mach. Syst. (ICEMS), 2016 19th Int. Conf.*, no. 2.
- [2] G M Hashmi and M Lehtonen 2007 On-line PD measuring system modeling and experimental verification for covered-conductor overhead distribution lines *2007 Mediterr. Conf. Control Autom. MED*, pp. 0–5.
- [3] G Robles, J M Martínez, J Sanz, B Tellini, C Zappacosta and M Rojas 2008 Designing and tuning an air-cored current transformer for partial discharges pulses measurements *Conf. Rec. - IEEE Instrum. Meas. Technol. Conf.*, pp. 2021–2025.
- [4] M Argüeso, G Robles, and J Sanz 2005 Implementation of a Rogowski coil for the measurement of partial discharges *Rev. Sci. Instrum.*, vol. 76, no. 6.
- [5] M Kunicki 2017 Comparison of capacitive and inductive sensors designed for partial discharges measurements in electrical power apparatus *E3S Web Conf.*, vol. 19, p. 01035.
- [6] M Shafiq, L Kutt, M Lehtonen, T Nieminen and M Hashmi 2013 Parameters identification and modeling of the high-frequency current transducer for partial discharge measurements *IEEE Sens. J.*, vol. 13, no. 3, pp. 1081–1091.
- [7] M Shafiq, M Lehtonen, L K Tt, G A Hussain, and M Hashmi 2013 Effect of terminating resistance on high-frequency behavior of Rogowski coil for transient measurements *Elektron. Ir Elektrotehnika*, vol. 19, no. 7, pp. 22–28.
- [8] M V R Moreno, G Robles, R Albarracín, J A Rey and J M M Tarifa 2017 Study on the self-integration of a Rogowski coil used in the measurement of partial discharges pulses *Electr. Eng.*, vol. 99, no. 3, pp. 817–826.
- [9] P Saetang and A Suksri 2016 The Design and Optimization of Combined Rogowski Coil Based on Printed Circuit Board *MATEC Web Conf.* 70, vol. 10014, pp. 7–10.
- [10] S M D William H Hayt, Jack E Kemmerly 2015 *Engineering Circuit Analysis*, Sixth., vol. 1542, no. 9. New York:: McGraw-Hill.