

## Low-voltage ride-through for a three-phase four-leg photovoltaic system using SRFPI control strategy

Haval Sardar Kamil<sup>1</sup>, Dalila Mat Said<sup>2</sup>, Mohd Wazir Mustafa<sup>3</sup>, Mohammad Reza Miveh<sup>4</sup>, Nasarudin Ahmad<sup>5</sup>

<sup>1,2</sup>Centre of Electrical Energy Systems (CEES), Universiti Teknologi Malaysia (UTM), Malaysia

<sup>1,2,3,5</sup>School of Electrical Engineering, Universiti Teknologi Malaysia (UTM), Malaysia

<sup>4</sup>Department of Electrical Engineering, Tafresh University, Iran

---

### Article Info

#### Article history:

Received Jun 3, 2018

Revised Nov 30, 2018

Accepted Dec 15, 2018

---

#### Keywords:

Four-leg inverter

Grid fault

LVRT

Photovoltaic (PV)

Renewable energy

---

### ABSTRACT

With the innovative progresses in power electronics in recent years, photovoltaic (PV) systems emerged as one of the promising sources for electricity generation at the distribution network. Nonetheless, connection of PV power plants to the utility grid under abnormal conditions has become a significant issue and novel grid codes should be recommend. The low-voltage ride-through (LVRT) capability is one of the challenges faced by the integration of PV power stations into electrical grid under abnormal conditions. This work firstly provides a discussion on recent control schemes for PV power plants to enhance the LVRT capabilities. Next, a control scheme for a three-phase four-leg grid-connected PV inverter under unbalanced grid fault conditions using synchronous reference frame proportional integral (SRFPI) controller is proposed. Simulation studies are performed to investigate the influence of the control strategy on the PV inverter.

Copyright © 2019 Institute of Advanced Engineering and Science.  
All rights reserved.

---

### Corresponding Author:

Dalila Mat Said,

Centre of Electrical Energy Systems (CEES),

School of Electrical Engineering, Faculty of Engineering,

Universiti Teknologi Malaysia (UTM),

Johor Bahru 81310, Johor, Malaysia.

Email: dalila@utm.my

---

## 1. INTRODUCTION

In recent years, there has been an increasing interest in integration of photovoltaic (PV) power plants in the modern power systems [1-3]. The global growth in solar PV installation capacity all over the world from 2005 to 2016 is shown in Figure 1 [4]. As can be observed, the capacity of the installed PV system had surprisingly increased. However, the high penetration of photovoltaic PV systems in the power grid may deteriorate the stability and power quality of the utility grid [5]. On the other hand, investigators have also examined the negative effects of the utility grid on PV power plants, such as the impacts of grid faults on solar PV power systems [6].

PV systems should guarantee a robust and safe performance under grid faults to offer valuable ancillary services such as voltage stability for the utility grid. Nonetheless, to reach a reliable operation during grid fault conditions, a number of technical issues have to be resolved [7]. In other words, the PV systems must be able to stay in connection to the utility grid under grid faults for reactive power injection [8]. The unregulated output power of PV power station under abnormal conditions can be regulated through power converters, and the power system reliability can be guaranteed depending on the performance of these power converters. Therefore, PV systems should be controlled properly at their point of common coupling (PCC) to keep PV systems connected to the utility grid under grid faults. In other words,

PV systems lose their sinusoidal appearance as a consequence of abnormal grid conditions. Oscillations in the output power is a challenging control issue, and the main cause of tripping PV systems from the network.

One critical component for any PV is the effectiveness of its operation under grid faults [9]. Developments in the conventional control solutions for power electronic interfaces in PV systems can fulfill the tight requirements imposed by the grid operator and provide the required stability, reliability and power quality during transient grid faults. Reactive power support, voltage recovery, frequency stability and ensuring that the PV systems remain connected to the grid without generating overcurrent are the main requirements of PV generation systems under grid faults. Therefore, power and energy engineers everywhere are pondering the challenges of operation of PV power station under abnormal conditions, as it is the most way to improve the power quality, stability and reliability of utility grid with the high penetration of the PV systems [10]. To achieve the stable operation and appropriate integration, it is required for PV systems to provide a low-voltage ride-through (LVRT) capability and maintain grid functionality during fault conditions [11].

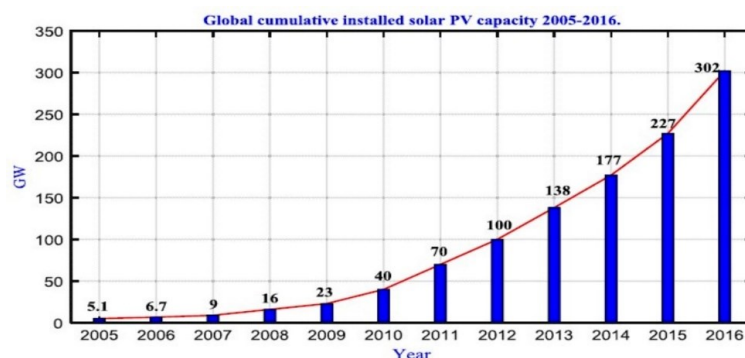

Figure 1. The global growth in solar PV installation capacity all over the world from 2005 to 2016 [4]

Even though many studies have been done to handle the challenging problems of supporting utility grid during abnormal conditions, there appears to be an absence of a comprehensive study on LVRT methods in PV systems. Moreover, smart microgrids are now standardized in most of countries; therefore, a review on LVRT control techniques and proposing an improved control scheme for security operational criterion for PV inverter is required. Therefore, in this paper, a control scheme for a three-phase four-leg grid-connected PV inverter under abnormal conditions using synchronous reference frame proportional integral (SRFPI) controller is suggested. The rest of this work has been divided into four parts. Section 2 presents the LVRT requirements in PV systems. Section 3 presents the existing LVRT control approaches for PV systems. Proposed control strategy and simulation results are given in Section 4. The conclusion is also given in section 5.

## 2. LVRT IN PV SYSTEMS

Voltage stability issues, fault detection, current control and oscillation of the active and the reactive powers are recognized as a serious concern in distribution networks under abnormal conditions with the increasing level of PV system penetration [12]. Grid faults are the leading cause of over-voltage and over-current at the both DC and AC sides of PV inverters and the oscillation of output powers at the PCC of the PV system [13]. Under abnormal conditions, the inverter must be disconnected from the power grid as the voltage and current exceed their limits. Generally, for continuous operation of the PV systems under abnormal conditions, the voltage should not be more than 1.10 p.u and less than 0.85 p.u [14, 15]. Under abnormal conditions, reactive power injection can be provided by PV systems for supporting the grid and regulating the amplitude of output voltages.

In order to remain PV inverters connected to the distribution networks as well as to provide reactive power improvement and frequency stability during fault conditions, the general LVRT requirements of PV generation systems should be considered [16]. Even though LVRT regulation issues for wind farms is a well-developed research topic, for PV inverters, it is not as well established as other distributed generations like doubly-fed wind turbine generator system. Moreover, the specific requirements and standards of LVRT regulation issues vary from country to country [17]. The LVRT limiting curves defined by different countries is depicted in Figure 2. As seen, the maximum reactive power injection is needed, whenever the voltage drop

value is above the curve for a given specific time, and the PV system must remain connected to the power grid. However, the maximum reactive power injection can be limited by the inverter's active power and apparent power. Moreover, reference generation control methods are needed for PV systems to calculate the current that must be injected into the system. Therefore, it requires the design of improved reference generation control strategies to extend the controllability of the PV system by cancelling the oscillation of output powers under grid faults. In the next section, available LVRT methods for PV systems are presented.

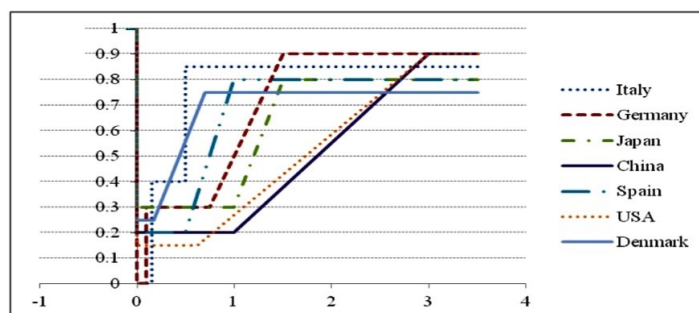

Figure 2. LVRT requirements defined by different countries [4]

### 3. LVRT CONTROL STRATEGIES FOR PV SYSTEMS

Al-Durra et al. [18], propose LVRT control strategies for a three-phase quasi Z source (QZS) PV inverter under voltage sag. The control of the shoot-through duty cycle give the ability to the QZS inverter to provide any desired output AC voltage. The proposed controllers have the ability to operate in the maximum power, regulate the inverter DC-link voltage, maintain the grid voltage at the desired level, provide voltage ride-through capability and keep the DC-link voltage within the acceptable limits. In this study, three LVRT control schemes are implemented using control modification in the system and hardware modification in the circuit topology to enhance the LVRT capability of the system.

In [19], a continuous mixed  $p$ -norm (CMPN) algorithm-based adaptive proportional-integral (PI) regulator is proposed to improve the LVRT ability of PV inverters. This scheme tune the gain of PI regulator online and without optimization methods. The maximum power point tracking (MPPT) operation is achieved using the DC-DC converter. It is implemented using the fractional open circuit voltage scheme. The DC-DC power converter controller implemented using the duty cycle of transistor.

Lin et al. [20], present a Takagi-Sugeno-Kang type probabilistic fuzzy neural network controller with asymmetric membership function (TSKPFNN-AMF) for a PV system under abnormal conditions. The DC-link bus voltage controller and PV-MPPT control scheme are used to guarantee the power balance under abnormal conditions. In order to adequately guarantee the active power balance between boost converter and three phase power converter in abnormal conditions, a dual mode operation strategy is suggested. Reactive power control and output current control without exceeding the maximum current limit are the main responsibility of the inverter of the PV system.

In [21], a recurrent fuzzy cerebellar model articulation neural network (RFCMANN) LVRT control strategy for a PV system under abnormal condition is proposed. To reach this purpose, a VSI operating in a current control mode is used as the single-stage three-phase PV unit. To calculate the ratio of the feeded reactive current in abnormal condition, a novel formula is suggested. It is introduced based on the voltage unbalance factor. A modified signed distance is also presented to convert the two variables of input space into sole variable and to minimize the complication of the proposed scheme.

In [11], a feedback linearizing control (FLC) with sliding mode LVRT scheme for a PV system is suggested. The proposed control scheme contains normal and abnormal conditions. The proposed scheme under normal conditions is implemented based on the maximum power transfer from the photovoltaic system to the power system with the MPPT operation of the inverter. The suggested scheme under normal conditions is also responsible for controlling the DC-link voltage and the current at the inverter-grid side. On the other hand, the active power is controlled under grid faults to minimize the current surplus, while the reactive power is fed to keep away from the inverter disconnection. To improve the robustness of controller to uncertainties a sliding mode approach is used in the proposed scheme.

N.H. Saad et al. [22], propose an improved particle swarm optimization (IPSO) method based on modulation index swarm to increase the LVRT capability of a two-stage PV system as shown in Figure 3, under abnormal condition. The proposed scheme contains a three-phase three level inverter and a DC-DC

converter on the basis of current-source full-bridge power converter with an embedded high-frequency transformer and rectifier. In [23], an improved PR-based LVRT control scheme for a PV system under unbalanced grid voltages is proposed. The PR controller has the ability to regulate the PV system output variables based on symmetrical components of three-phase grid voltage. The use of symmetrical components including positive and negative sequence components in the current controller do not introduce any delay or error in the control system. Hence, dynamic regulation performance of the proposed controller under abnormal condition is enhanced. Moreover, the LVRT ability of grid-connected PV system is enhanced. The negative sequence components of grid currents under grid faults can be effectively compensated using the proposed PR controller. Additionally, the oscillations in the output power and current can be eliminated with the proposed control scheme.

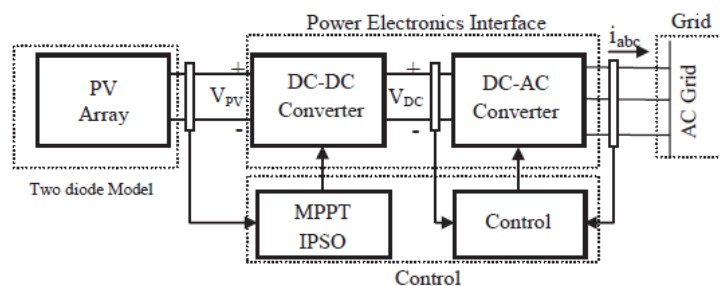

Figure 3. Block diagram of the PV system in [22]

Sun et al. [24], propose an improved LVRT control strategy based on symmetrical components for a QZS inverter used for grid-connected PV power station. Whenever the power grid voltage disturbance is detected, the system holds the value of shoot-through duty ratio and cancels the MPPT scheme until the fault clears so as to enhance the stability of DC-link voltage during the LVRT period. When the power grid voltage gets back to normal, the system recovers the double-loop control and the MPPT control.

In [25], authors have presented a transformerless three-level photovoltaic power converter and the consequences of the unbalanced faults on the inverter's neutral point for LVRT operation are figured out. Moreover, new proposed control techniques are carried out to further balance the voltage oscillations on the neutral point of the inverter under unbalanced faults. In [26], Ma and his research group investigate a three-phase system, which offers six current control freedoms with a zero-sequence current path to alleviate both active and reactive power fluctuations and inject sinusoidal currents as well. However, the constant dc source has been used, the drawbacks of the unbalanced faults on the capacitive DC-link have not been investigated. Cardenas et al. [27], assume that the DC-link voltage is to be constant. This assumption is inappropriate in terms of the unbalanced fault as overall power would not be zero and the ripple would be produced to the DC-link voltage.

Afshari et al.[28], propose a model for PV source at the input side system, the performance of the proposed technique is only evaluated through simulations. The proposed control strategy including two operational modes, MPPT and non-MPPT modes, which they may operate under unbalanced conditions. The authors of [29], illustrated the LVRT operation of current source grid-connected PV inverters under unbalanced voltages. Moreover, the proposed method developed negative sequence current reference to abolish active power double frequency fluctuations at the Ac side of the current source grid connected PV inverter. Guo et al.[30], proposed a new fault ride through FRT control strategy for grid connected inverters. In the proposed method a pick current can control within the rated value effectually. A flexible control strategy for three-phase PV inverters operating under unbalanced faults is discussed, nevertheless, the control of the renewable energy source has not been explored.

#### 4. CONTROL STRATEGY AND SIMULATION RESULTS

In order to compensate positive and negative components, a proportional integral controller in the dq frame is proposed in this part. The three-phase four-leg power converter used in [31], is used for simulations. Figure 4 shows the structure of the SRFPI current controller used for the four-leg power converter. As seen, three-phase currents in the  $\alpha\beta$  frame converted into positive and negative dq currents in the SRF firstly, and then the currents in the dq frame are compensated using four PI controllers. Finally, the signals in the dq frame are converted into the  $\alpha\beta$  frame for generating gate signals for the pulse width modulation.

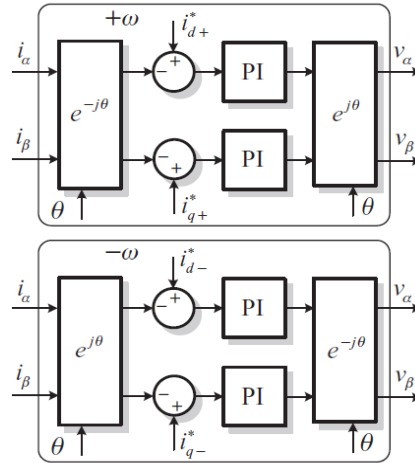

Figure 4. SRFPI current controller

The controller has been applied in a three-phase four-leg PV inverter. The voltage is 155.56 V peak at 50 Hz. Simulation studies are carried out by means of the DIgSILENT Power Factory software. The parameters of the four-leg inverter are: DC bus voltage: 380V, filter capacitance: 2.2μF, filter inductance: 11mH, fundamental frequency 50Hz, switching frequency 20kHz, damping resistance 3.5Ω.

The output active and reactive power of the PV inverter under unbalanced grid faults condition is depicted in Figure 5. As seen, the active power oscillation is mitigated using the positive and negative control scheme from 0s to 0.25s. Additionally, the reactive power oscillation is removed by the control scheme from 0.25s to 0.5s. The positive and negative currents in the dq frame are also illustrated in Figure 6, which shows a precise controllability on the current controller. Figure 7 also shows the three-phase output current of the four-leg PV inverter and its neutral current under abnormal condition. The SRFPI controller has the ability to mitigate the active power or reactive power oscillation under abnormal conditions using four current control freedoms; however, it is not enough to attain acceptable performances under this condition. Therefore, more research on this topic needs to improve the controllability of the converter with the zero sequence current path, with six current control freedoms in order to cancel the oscillations of the active and the reactive power at the same time.

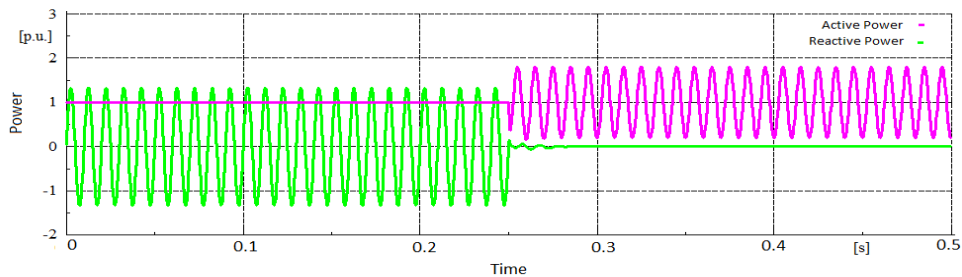

Figure 5. Output active and reactive power under unbalanced grid faults

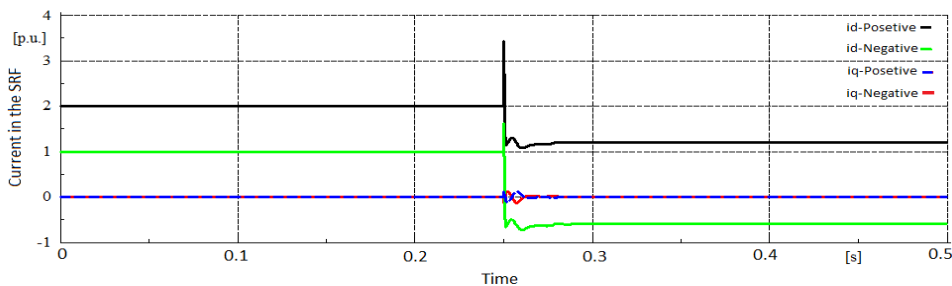

Figure 6. Positive and negative currents in the dq frame

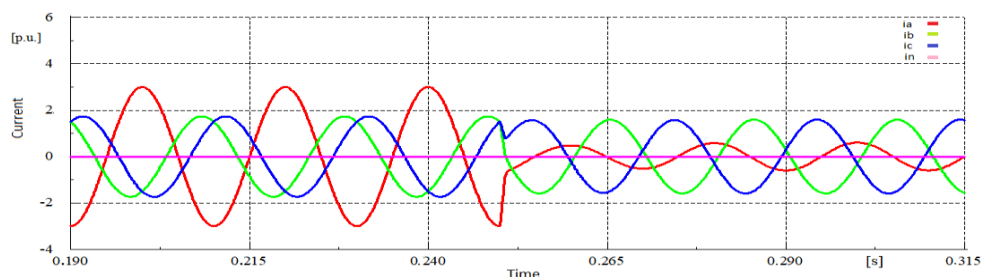

Figure 7. The output currents of the four-leg PV inverter

## 5. CONCLUSION

This paper presented a review of recent LVRT control schemes for PV power stations operating under abnormal conditions. To meet the new grid code needs in the previous studies, several methods to cope with fault detection, current control, and power balance in a PV system are presented. This paper has also proposed a control scheme for the three-phase PV converter under unbalanced grid faults in the dq frame using four PI controllers. Among the main contributions of the suggested technique is the elimination of the double grid frequency fluctuations in the active or reactive power under unbalanced faults by controlling the positive and negative sequence currents. However, further work is required to mitigate the oscillations of the active and the reactive power simultaneously.

## ACKNOWLEDGEMENTS

The authors would like to acknowledge the support of the Ministry of Education, Malaysia and Universiti Teknologi Malaysia through research grants Q.J130000.2423.03G88 and Q.J130000.2523.17H64.

## REFERENCES

- [1] Y. Yang, Q. Ye, L. J. Tung, M. Greenleaf, and H. Li, "Integrated size and energy management design of battery storage to enhance grid integration of large-scale PV power plants," *IEEE Transactions on Industrial Electronics*, vol. 65, no. 1, pp. 394-402, 2018.
- [2] G. Stein and T. M. Letcher, "Integration of PV Generated Electricity into National Grids," in *A Comprehensive Guide to Solar Energy Systems: Elsevier*, pp. 321-332, 2018.
- [3] L. Naik, "Design and Performance of a PV-STATCOM for Enhancement of Power Quality in Micro Grid Applications," *International Journal of Power Electronics and Drive Systems (IJPEDS)*, vol. 8, no. 3, pp. 1408-1415, 2017.
- [4] A. Q. Al-Shetwi and M. Z. Sujod, "Grid-connected photovoltaic power plants: A review of the recent integration requirements in modern grid codes," *International Journal of Energy Research*, vol. 42, no. 5, pp. 1849-1865, 2018.
- [5] M. L. Sabo, N. Mariun, H. Hizam, M. A. M. Radzi, and A. Zakaria, "Spatial matching of large-scale grid-connected photovoltaic power generation with utility demand in Peninsular Malaysia," *Applied Energy*, vol. 191, pp. 663-688, 2017.
- [6] S. K. Bhuyan, P. K. Hota, and B. Panda, "Power Quality Analysis of a Grid-connected Solar/Wind/Hydrogen Energy Hybrid Generation System," *International Journal of Power Electronics and Drive Systems (IJPEDS)*, vol. 9, no. 1, pp. 377-389, 2018.
- [7] A. Naderipour, A. M. Zin, M. Habibuddin, M. Moradi, M. Miveh, and H. Afrouzi, "A new compensation control strategy for grid-connected wind turbine and fuel cell inverters in a microgrid," *International Journal of Power Electronics and Drive Systems (IJPEDS)*, vol. 8, no. 1, pp. 272-278, 2017.
- [8] H. D. Tafti, A. I. Maswood, G. Konstantinou, J. Pou, and C. D. Townsend, "Low-voltage ride-through capability of full-row connected cascaded H-bridge converters," in *Region 10 Conference (TENCON)*, 2016 IEEE, pp. 984-987: IEEE, 2016.
- [9] M. K. Hossain and M. H. Ali, "Low voltage ride through capability enhancement of grid connected PV system by SDBR," in *T&D Conference and Exposition*, IEEE PES, 2014, pp. 1-5: IEEE, 2014.
- [10] M. K. Hossain and M. H. Ali, "Fuzzy logic controlled power balancing for low voltage ride-through capability enhancement of large-scale grid-connected PV plants," in *Power and Energy Conference (TPEC)*, IEEE Texas, pp. 1-6: IEEE, 2017.
- [11] A. Merabet, L. Labib, A. M. Ghias, C. Ghenai, and T. Salameh, "Robust Feedback Linearizing Control With Sliding Mode Compensation for a Grid-Connected Photovoltaic Inverter System Under Unbalanced Grid Voltages," *IEEE Journal of Photovoltaics*, vol. 7, no. 3, pp. 828-838, 2017.

- [12] G. Hunter, I. Andrade, J. Riedemann, R. Blasco-Gimenez, and R. Peña, "Active and reactive power control during unbalanced grid voltage in PV systems," in *Industrial Electronics Society, IECON 2016-42nd Annual Conference of the IEEE*, pp. 3012-3017: IEEE, 2016.
- [13] F. Zheng, X. Zhang, J. Zhang, and J. Huang, "LVRT control strategy for photovoltaic inverter based on current derating," 2015.
- [14] J. L. Sosa, M. Castilla, J. Miret, J. Matas, and Y. Al-Turki, "Control strategy to maximize the power capability of PV three-phase inverters during voltage sags," *IEEE Transactions on Power Electronics*, vol. 31, no. 4, pp. 3314-3323, 2016.
- [15] N. Jaalam, N. Rahim, A. Bakar, and B. Eid, "Strategy to enhance the low-voltage ride-through in photovoltaic system during multi-mode transition," *Solar Energy*, vol. 153, pp. 744-754, 2017.
- [16] R. K. Varma, S. A. Rahman, V. Sharma, and T. Vanderheide, "Novel control of a PV solar system as STATCOM (PV-STATCOM) for preventing instability of induction motor load," in *Electrical & Computer Engineering (CCECE), 25th IEEE Canadian Conference on*, 2012, pp. 1-5: IEEE, 2012.
- [17] H. Tian, F. Gao, C. Ma, G. He, and G. Li, "A review of low voltage ride-through techniques for photovoltaic generation systems," in *Energy Conversion Congress and Exposition (ECCE), 2014 IEEE*, pp. 1566-1572: IEEE, 2014.
- [18] A. Al-Durra, Y. Fayyad, S. Muyeen, and F. Blaabjerg, "Fault Ride-through of a Grid-connected Photovoltaic System with Quasi Z Source Inverter," *Electric Power Components and Systems*, vol. 44, no. 16, pp. 1786-1800, 2016.
- [19] H. M. Hasanien, "An adaptive control strategy for low voltage ride through capability enhancement of grid-connected photovoltaic power plants," *IEEE Transactions on Power Systems*, vol. 31, no. 4, pp. 3230-3237, 2016.
- [20] F.-J. Lin, K.-C. Lu, T.-H. Ke, B.-H. Yang, and Y.-R. Chang, "Reactive power control of three-phase grid-connected PV system during grid faults using Takagi-Sugeno-Kang probabilistic fuzzy neural network control," *IEEE Transactions on Industrial Electronics*, vol. 62, no. 9, pp. 5516-5528, 2015.
- [21] F.-J. Lin, K.-C. Lu, and B.-H. Yang, "Recurrent Fuzzy Cerebellar Model Articulation Neural Network Based Power Control of a Single-Stage Three-Phase Grid-Connected Photovoltaic System During Grid Faults," *IEEE Transactions on Industrial Electronics*, vol. 64, no. 2, pp. 1258-1268, 2017.
- [22] N. H. Saad, A. A. El-Sattar, and A. E.-A. M. Mansour, "Improved particle swarm optimization for photovoltaic system connected to the grid with low voltage ride through capability," *Renewable Energy*, vol. 85, pp. 181-194, 2016.
- [23] X. Wang, Z. Yang, B. Fan, and W. Xu, "Control strategy of three-phase photovoltaic inverter under low-voltage ride-through condition," *Mathematical Problems in Engineering*, vol. 2015, 2015.
- [24] B. Sun, J. Mei, J. Zheng, and K. Deng, "Grid-connected photovoltaic system based on switched-inductor quasi-Z-source inverter and its low voltage ride-through control strategy," *Journal of Renewable and Sustainable Energy*, vol. 5, no. 3, p. 033120, 2013.
- [25] Z. Shao, X. Zhang, F. Wang, R. Cao, and H. Ni, "Analysis and control of neutral-point voltage for transformerless three-level PV inverter in LVRT operation," *IEEE Transactions on Power Electronics*, vol. 32, no. 3, pp. 2347-2359, 2017.
- [26] K. Ma, W. Chen, M. Liserre, and F. Blaabjerg, "Power controllability of a three-phase converter with an unbalanced AC source," *IEEE Transactions on Power Electronics*, vol. 30, no. 3, pp. 1591-1604, 2015.
- [27] R. Cárdenas, M. Díaz, F. Rojas, J. Clare, and P. Wheeler, "Resonant control system for low-voltage ride-through in wind energy conversion systems," *IET Power Electronics*, vol. 9, no. 6, pp. 1297-1305, 2016.
- [28] E. Afshari, B. Farhangi, Y. Yang, and S. Farhangi, "A low-voltage ride-through control strategy for three-phase grid-connected PV systems," in *Power and Energy Conference at Illinois (PECI), 2017 IEEE*, pp. 1-6: IEEE, 2017.
- [29] Z. Wang, B. Wu, D. Xu, M. Cheng, and L. Xu, "Dc-link current ripple mitigation for current-source grid-connected converters under unbalanced grid conditions," *IEEE Transactions on Industrial Electronics*, vol. 63, no. 8, pp. 4967-4977, 2016.
- [30] X. Guo, W. Liu, and Z. Lu, "Flexible power regulation and current-limited control of the grid-connected inverter under unbalanced grid voltage faults," *IEEE Transactions on Industrial Electronics*, vol. 64, no. 9, pp. 7425-7432, 2017.
- [31] H. S. Kamil, D. M. Said, M. W. Mustafa, M. R. Miveh, N. Rosmin, and N. Ahmad, "DIgSILENT modelling of a four-leg power converter using a triangular carrier wave," in *Energy Conversion (CENCON), 2017 IEEE Conference on*, pp. 343-348, IEEE, 2017.