

PAPER • OPEN ACCESS

Performance Analysis of Filtered VHF Signals Captured by Lightning Interferometer System

To cite this article: N. A. I. Azmi *et al* 2019 *IOP Conf. Ser.: Earth Environ. Sci.* **228** 012005

View the [article online](#) for updates and enhancements.

Performance Analysis of Filtered VHF Signals Captured by Lightning Interferometer System

N. A. I. Azmi¹, M. R. Ahmad¹, M. R. M. Esa², M. H. M. Sabri¹, D. Periannan¹, B. Y. Seah¹, S. A. Mohamad², G. Lu³, N. Yusop⁴, M. M. Ismail¹, V. Cooray⁵, A. A. Alkahtani⁶ and M. Z. A. AB. Kadir⁶

¹Atmospheric and Lightning Research Lab, Centre for Telecommunication Research and Innovation (CeTRI), Fakulti Kejuruteraan Elektronik dan Kejuruteraan Komputer, Universiti Teknikal Malaysia Melaka, Hang Tuah Jaya, 76100 Durian Tunggal, Melaka, Malaysia.

²Institute of High Voltage and High Current (IVAT), School of Electrical Engineering, Faculty of Engineering, Universiti Teknologi Malaysia (UTM), 81310 Skudai, Johor Bharu, Malaysia

³Institute of Atmospheric Physics, Chinese Academy of Sciences, China.

⁴Space Science Centre (ANGKASA), Institute of Climate Change, Universiti Kebangsaan Malaysia, 43600 Bangi, Selangor, Malaysia

⁵Ångström Laboratory, Division for Electricity, Department of Engineering Sciences, Uppsala University, Box 534, S-75121, Sweden

⁶Universiti Tenaga Nasional (UNITEN), Jalan IKRAM-UNITEN, 43000 Kajang, Selangor.

Email: riduan@utem.edu.my

Abstract. A lightning interferometer is a system that can determine the location of Very High Frequency (VHF) radiation of lightning. Such system has been studied and used for several decades ago. In this project, VHF Interferometer is used to determine the location of VHF radiations emitted by Narrow Bipolar Event (NBE) lightning flash by correlating the signals that received at three antennas. In order to get the better result, cross-correlation algorithm technique is employed to process the signals. This algorithm can determine the time delay between the antennas baselines and then determine the azimuth and elevation angles which are used to locate the location of the NBE flash. This interferometer system also can act as an earlier warning system as it detects the first cloud flash and a forecast can be made before cloud-to-ground flashes occur. Therefore, this interferometer system is very useful for the public citizens in protecting themselves from lightning strikes.



1. Introduction

Nowadays, there's a lot of interest in lightning-related research. In particular, studies have been done to understand better about lightning phenomenon including three common types which are Intracloud (IC), Cloud to Ground (CG), and Bolts from the Blue (BLB) [1][2]. The locating system is very useful because it can detect and warn an incoming lightning strike anytime. It gives a lot of benefit to public citizens because they will receive the warning message at the very earliest time when lightning strikes are approaching. It may expose the people near the lightning strike location to danger when they are doing the outdoor activities. A lightning detector was created which is able to detect the lightning strike distance will be useful for the public citizens in protecting themselves from lightning strikes. In the end of the project, we need to analyze the differences between original and filtered signal based on signal processing method. Therefore, in this paper there are four objective which are to design and develop the VHF interferometer with two baselines. A part from that, is to process the analog signal of VHF radiation by sing MATLAB application and produce VHF lightning mapping by using interferometer techniques to determine the direction of arrival of radiation.

Several scopes are listed to ensure the research is conducted within its intended boundary. In this paper, it has two parts; first is experimental work. For the experimental part, the measurement was conducted in wide area such as at Pantai Klebang or in open field in UTeM. The second part is software which is signal processing plays the main role in order to locate the lightning location by using cross correlation technique.

2. Methodology

A. Interferometer Design

The VHF antenna system based on interferometer technique is designed and developed as shown in Figure 1 where the system should be arranged perpendicularly and crossed baselines to each other [4]. This perpendicular baseline interferometer can locate the VHF radiation sources hence VHF radiation source signal received at three capacitive antennas, the signal undergoes radio system that includes bandpass filter 40-80 MHz bandwidth at centered frequency 60 MHz [5]. The signal transfer to LNA in order to amplify the weak signals that received by the antennas. By using LNA, the effect of noise also could be reduced by the gain of an amplifier. After that, the analogue signal will be processed to the digital signal which is transfer the signal into the PicoScope 3000 series via the cable. PicoScope is a tool that can display the voltage waveforms of the signal by using a computer. Then, MATLAB application will take an action to do the signal processing part for plotting the lightning mapping that retrieved from PicoScope. The lightning mapping can be done by using the cross-correlation technique in signal processing that locates the VHF radiation sources. Once the MATLAB coding is run correctly, the resulted of lightning mapping is displayed in both azimuthal and elevational. So that the result obtained can be analyzed and presented.

Communication channel is the path that data takes from transmitter to the destination. Communication channel also known as transmission media or communication media. Communication channel is divided into types which are guided (wired) and unguided (wireless).

In wired communication information is transferred between two or more nodes using wires while in wireless communication information is transferred between two or more nodes that are not connected using electrical conductor. An information is transmitted via open space known as radio waves [8]. Radio waves are generated by radio transmitter and received at the radio receiver. During the

transmission from a transmitting antenna to a receiver, path loss occurs due to the propagation medium. The basic propagation loss is shown in Figure 1.

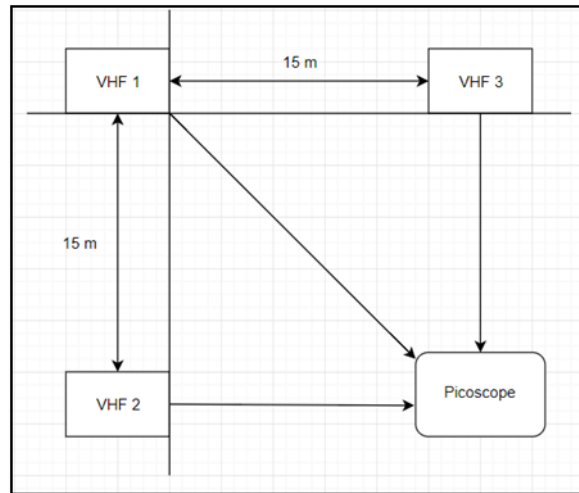

Figure 1. Very High Frequency (VHF) Interferometer System

B. Signal Processing

To process the lightning signal that retrieved from PicoScope, cross-correlation technique is used which estimate time delay. Some equations were involved in order to get the better accuracy of the time delay.

$$d \cos \alpha = c\tau_d = \left(\frac{\Delta\phi}{2\pi}\right) \lambda \tag{1}$$

Based on the equation (1), the value of direction cosine and τ_d are different. So that the equation should be modified as equation (2) and (3).

$$d \cos \alpha = c\tau_{d1} = \left(\frac{\Delta\phi}{2\pi}\right) \lambda \tag{2}$$

$$d \cos \beta = c\tau_{d2} = \left(\frac{\Delta\phi}{2\pi}\right) \lambda \tag{3}$$

To determine azimuth and elevation angle, equations (4) and (5) are needed.

$$\cos \alpha = \sin(Az)\cos(El) \tag{4}$$

$$\cos \beta = \cos(Az)\cos(El) \tag{5}$$

From equations (4) and (5) it can be derived to equations (6) and (7).

$$\cos \alpha = \frac{c\tau_{d1}}{d} \tag{6}$$

$$\cos \beta = \frac{c\tau_{d2}}{d} \quad (7)$$

Then $\cos \alpha$ divide by $\cos \beta$ in equations (6) and (7).

$$\frac{\cos \alpha}{\cos \beta} = \frac{\tau_{d1}}{\tau_{d2}} = \frac{\sin Az}{\cos Az} \quad (8)$$

$$\tan Az = \frac{\tau_{d1}}{\tau_{d2}} \quad (9)$$

The azimuth angle then can be calculated by derived from equation (9) as

$$Az = \arctan\left(\frac{\tau_{d1}}{\tau_{d2}}\right) \quad (10)$$

Equation (4) is needed to be derived the elevation angle equation.

$$\begin{aligned} \cos El &= \frac{\cos \alpha}{\sin Az} \\ \cos El &= \frac{\frac{c\tau_{d1}}{d}}{\sin \arctan\left(\frac{\tau_{d1}}{\tau_{d2}}\right)} \end{aligned} \quad (11)$$

Since,

$$\begin{aligned} \sin[\arctan(x)] &= \frac{x}{\sqrt{1+x^2}} \\ \cos El &= \frac{c\tau_{d1} \left(\sqrt{1 + \left(\frac{\tau_{d1}}{\tau_{d2}}\right)^2} \right)}{d \left(\frac{\tau_{d1}}{\tau_{d2}}\right)} \\ \cos El &= \frac{c\tau_{d1} \left(\sqrt{\frac{\tau_{d1}^2 + \tau_{d2}^2}{\tau_{d2}^2}} \right)}{d \left(\frac{\tau_{d1}}{\tau_{d2}}\right)} \\ \cos El &= \frac{c \frac{\tau_{d1}}{\tau_{d2}} \left(\sqrt{\tau_{d1}^2 + \tau_{d2}^2} \right)}{d \left(\frac{\tau_{d1}}{\tau_{d2}}\right)} \\ \cos El &= \frac{c}{d} \sqrt{\tau_{d1}^2 + \tau_{d2}^2} \end{aligned} \quad (12)$$

For equation (5),

$$\cos El = \frac{\cos \beta}{\cos Az}$$

$$\cos El = \frac{\frac{c\tau_{d2}}{d}}{\cos \arctan\left(\frac{\tau_{d1}}{\tau_{d2}}\right)}$$

Since,

$$\begin{aligned} \cos[\arctan(x)] &= \frac{1}{\sqrt{1+x^2}} \\ \cos El &= \frac{\frac{c\tau_{d2}}{d}}{1/\sqrt{1+\left(\frac{\tau_{d1}}{\tau_{d2}}\right)^2}} \\ \cos El &= \frac{c\tau_{d2}\left(\sqrt{1+\left(\frac{\tau_{d1}}{\tau_{d2}}\right)^2}\right)}{d} \\ \cos El &= \frac{c\tau_{d2}\left(\sqrt{\frac{\tau_{d1}^2+\tau_{d2}^2}{\tau_{d2}^2}}\right)}{d} \\ \cos El &= \frac{c}{d}\sqrt{\tau_{d1}^2+\tau_{d2}^2} \end{aligned} \quad (13)$$

The derived elevation equation is then given as:

$$El = \arccos\left(\frac{c}{d}\sqrt{\tau_{d1}^2+\tau_{d2}^2}\right) \quad (14)$$

3. Results and analysis

To plot all the samples from the lightning signal, loop function has been used to repeat the same procedure as a single window. The 256 samples were shifting about 32 samples. Because of that, the first window and the next window should be overlapped according to Stock et. al [3]. Figure 2 shows the visualization of the lightning signal which is overlapped and shifting about 32 samples. From the shifting process, the next process is looping. The single window needed to repeat the same procedure in order to mapping all the samples in the same figure. However, the time difference, $\tau(d)$ which is for 'tauBC' and 'tauBD' should not exceed the transit time, $\tau_{\text{transit}}=(d/c)$ [3]. So that, the value of 'tauBC' and 'tauBD' must fulfill the condition. Figure 3 shown the 'tauBC' for original signal that are not exceed than time transit τ_{transit} , 5×10^{-8} s. Figure 5 shows the lightning mapping of the original signal for the lightning strike. Figure 4 shows the lightning mapping for filtered signal. The pattern of the lightning mapping must be concentrated in a certain area and can be proved in Figure 4 and Figure 5.

Overall, to compare the result between original and filtered signal, the pattern of the filtered signal mapping is almost same as the original signal. However, there has been a little bit different especially for the movement of the lightning. This means the time for every location is a bit different based on the mapping in the figure. The area for the lightning strike should be happening in a certain area. Otherwise, it can be noise, or another lightning flash occurred in the same time.

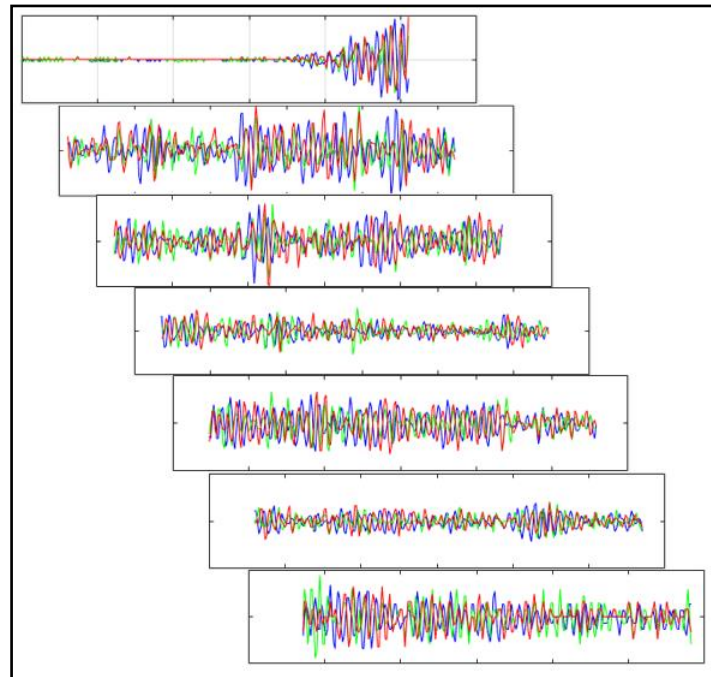

Figure 2. Visualization for Overlapped windows

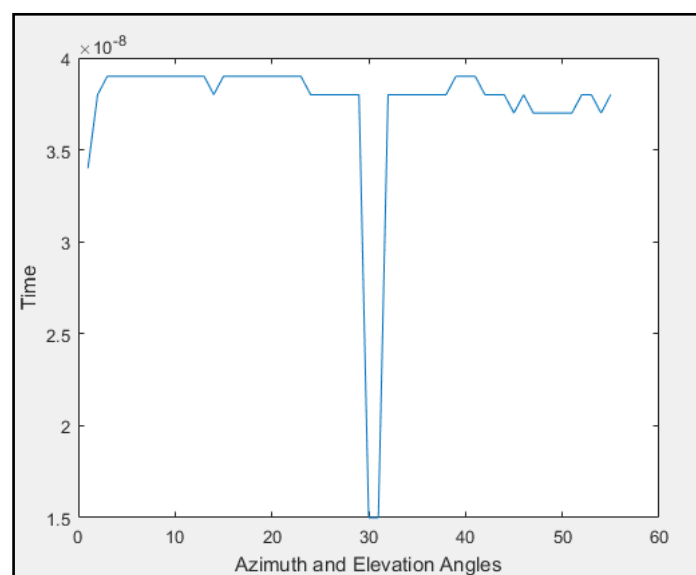

Figure 3. The time difference of 'tauBC' for original signal

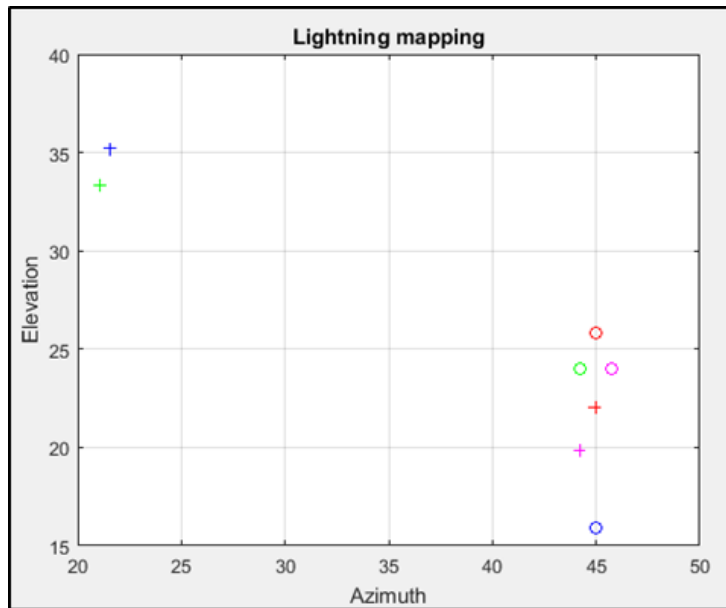

Figure 4. Lightning mapping for filtered signal

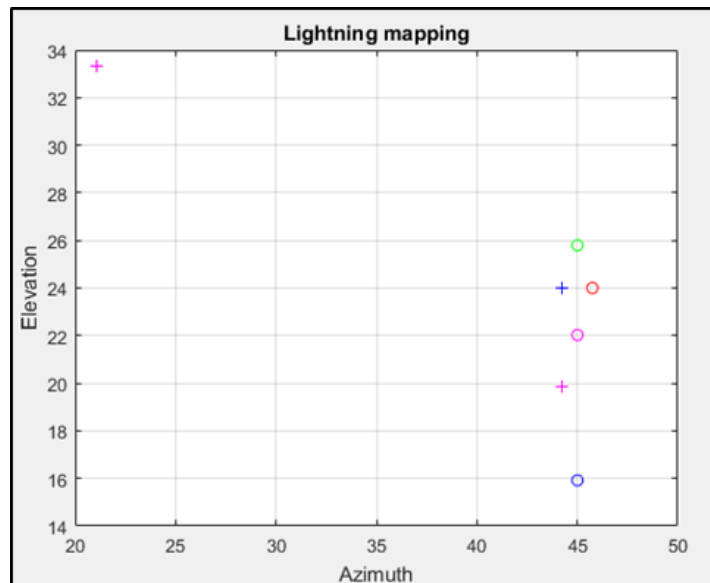

Figure 5. Lightning mapping for original signal

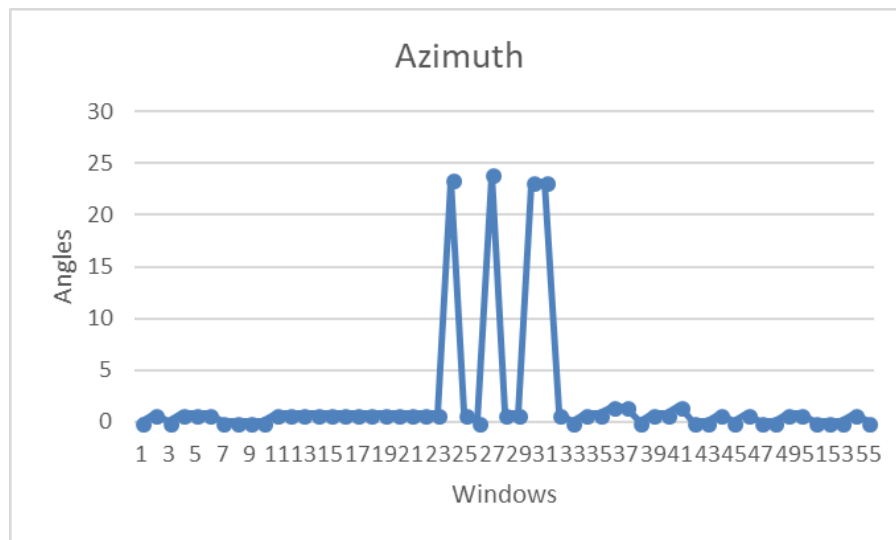

Figure 6. Differences between Original and Filtered Signal for Azimuth Angles

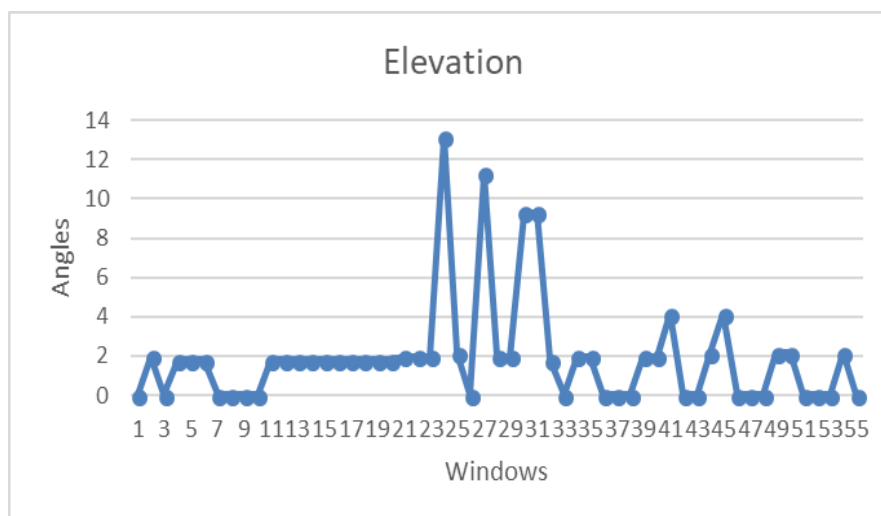

Figure 7. Differences between Original and Filtered Signal for Elevation Angle

4. Conclusion

The purpose of this research is about designing and developing the lightning location system using VHF Interferometer technique. The first objective is to design and develop the VHF Interferometer with two crossed baselines were achieved. Three capacitive antenna was placed in the wide area at Pantai Klebang. These antennas were arranged in perpendicular baseline and successfully received by three antennas as shown in Figure 1.

The second objective is to process the analogue signal of VHF radiation by using MATLAB application. The VHF signal that captured by antennas were undergone bandpass filter and low noise amplifier before transfer to PicoScope through a coaxial cable.

The third objective of this project is to produce VHF lightning mapping by using interferometer technique to determine the time of arrival, τ_d . The cross-correlation technique had been used to correlate the signal that received between two antennas. The result of lightning mapping can present in azimuth and elevation using several equations.

Acknowledgments

The authors would like to acknowledge the support provided by Fakulti Kejuruteraan Elektronik dan Kejuruteraan Komputer (FKEKK), Universiti Teknikal Malaysia Melaka (UTeM). This project is funded by Short Term Grant (Projek Jangka Pendek PJP) in FKEKK, UTeM (PJP/2018/FKEKK/(3B)/S01615). This project is partially funded by Universiti Teknologi Malaysia (UTM) under Vote No. 04G19 and Ministry of Education (MOE) under 4F966 research grants (FRGS).

References

- [1] Proctor, D., VHF radio pictures of cloud flashes. *Journal of Geophysical Research*. 1981, 86(C5), 4041-4071. 1,
- [2] Rison, W., R. Thomas, P. Krehbiel, T. Hamlin, and J. Harlin. A GPS based three dimensional lightning mapping system, *Geophysical research letters*. 1999, 26(23), 3573-3576. 1, 6.
- [3] Stock, M., M. Akita, P. Krehbiel, W. Rison, H. Edens, Z. Kawasaki, and M. Stanley. Continuous broadband digital interferometry of lightning using a generalized cross-correlation algorithm. *Journal of Geophysical Research: Atmospheres*. 2014, 119 (6), 3134-3165. 15, 26, 39, 40, 64, 65, 103,
- [4] Hayenga, C., and J. Warwick. Two-dimensional interferometric positions of VHF lightning sources. *Journal of Geophysical Research*. 1981, 86 (C8), 7451-7462. 3, 4, 39
- [5] Warwick, J. W., C. O. Hayenga, and J. W. Broshanan (1979), Interferometric directions of lightning sources at 34 MHz, *Journal of Geographic Research: Oceans* (1978-2012), 84 (C5), 2457-2468. 1,2,3.