



## Guidelines for Process Safety Hazard Assessment Based on Process Information

Muhammad Firdaus Husin<sup>1</sup>, Mimi H. Hassim<sup>1,2,\*</sup>, Denny K.S. Ng<sup>3</sup>, Anwar Johari<sup>1</sup>, Mohd. Johari Kamaruddin<sup>1</sup> & Norzita Ngadi<sup>1</sup>

<sup>1</sup>Department of Chemical Engineering /Centre of Hydrogen Energy, Faculty of Chemical and Energy Engineering, Universiti Teknologi Malaysia, 81310 Johor Bahru, Johor, Malaysia.

<sup>2</sup>Faculty of Chemical Engineering, Universiti Teknologi MARA, 40450 UiTM Shah Alam, Selangor, Malaysia

<sup>3</sup>Department of Chemical & Environmental Engineering/Centre of Excellence for Green Technologies, University of Nottingham Malaysia Campus, Broga Road, 43500 Selangor D.E., Malaysia

\*E-mail: chamberfirdaus@gmail.com

**Abstract.** In any new chemical process development and design, process safety is a critical aspect to be considered besides economic and technical feasibility of the manufacture of the product. A lack of proper hazard assessment during the design phase may later result in accidents with disastrous consequences to workers, the public as well as the environment. Many methods have been introduced to qualitatively and quantitatively assess the safety level of processes. Despite the availability of a large amount of methods, a systematic framework that details guidelines for hazard identification, risk assessment, safety measure design, and safe critical decision-making is still missing. To address this issue, the main objective of this study was to propose a systematic framework that outlines comprehensive guidelines for assessing the safety performance of processes based on information from the piping and instrumentation diagram (P&ID). Apart from proposing the framework, appropriate strategies for minimizing safety hazards and risks are also recommended. In addition, the user is assisted in selecting the most appropriate assessment method according to his or her needs and the scope and constraints of the assessment. A case study is presented to illustrate the application of the proposed framework.

**Keywords:** *chemical processes; hazard and risk assessment; piping and instrumentation diagram (P&ID); process safety; systematic framework.*

### 1 Introduction

Chemical industries, especially petrochemical and related industries, are ever expanding to fulfill global market demand. However, the increasing number of industrial chemical processes may cause a large number of accidents. Process safety engineering plays an important role in reducing the incidence of unexpected toxic release and other accidents at chemical facilities [1]. This

could easily be done during the design of chemical processes via different approaches, such as hazard identification and analysis strategies, risk assessment and evaluation, safety measures, and safe critical decision-making. A conventional process design lifecycle starts with screening the chemical reaction pathway and ends with the stage of producing the desired chemical product. To allow better communication between engineers, a flow diagram is normally used to represent the process. Flow diagrams can be separated into three types: (i) the block flow diagram (BFD), (ii) the process flow diagram (PFD), and (iii) the process and instrumentation diagram (P&ID).

The first document to be produced during the design stage is the BFD. This is a simplified flowsheet that shows the main steps of the process, which is depicted using rectangular blocks with input and output flow streams. In addition, it specifies operating conditions (temperature and pressure) and other important parameters, such as conversion and percentage of yield (PFD), which is the second outcome to be constructed after BFD. The PFD contains the bulk of process information necessary for the design of the chemical process and also carries more information than the BFD. The PFD also provides the relationships between major components, subsystems and the stream flow between them. Finally, the most detailed flow diagram is the P&ID. The P&ID is a type of documentation in the form of a diagram that acts as a reference point during the development of industrial processes, mainly in the chemical industry. It includes the arrangement of the process equipment, piping, pumps, instruments, valves and other fittings (see Table 1). Note that P&ID carries sufficient information to describe the piping and instrument details used in the process. Among the three types of diagrams, the last one, the P&ID, is the subject of this paper, since it is a crucial engineering document in the chemical process design stage. As stated in Kidam, *et al.* [2], most critical design errors that occur concern the construction materials, the protection system, the utilities setup and equipment sizing. These are all represented in the P&ID. As a result, several researchers have attempted to develop methods for ensuring an adequate level of protection against unexpected events by using process information generated from the P&ID. These are described in textbooks as well as in guidelines. Based on safety level assessment using the P&ID, there are various existing hazard identification and risk assessment methods that can be applied to evaluate process safety and other problems related to chemical processes. Among the frequently used methods are Hazard and Operability Study (HAZOP), Failure Mode Effect Analysis (FMEA), MOND Index, Fire and Explosion Index (F&EI), Chemical Exposure Index (CEI) and Quantitative Risk Assessment (QRA [2]. Among these, HAZOP is the most used in chemical process industries (CPI [3]. As stated by Taylor [4], it is usual to carry out HAZOP with P&ID to check if a design is safe in light of the ability to detect errors up to 95%. Meanwhile, the main purpose of F&EI (1987), which was introduced by

Dow Chemical Company, is to identify equipment that is likely to contribute to the creation of incidents. In addition, CEI (1987) was developed by Dow Chemical Company to be used as a method of rating relative acute health hazard (toxicity hazard) threats to people within chemical plants. Meanwhile, QRA has gained wide acceptance as a powerful tool to identify and assess significant sources of risk and to evaluate alternative risk control measures in chemical industries [5]. Unfortunately, the application of QRA in chemical process design is difficult due to the greater diversity of processes, hazardous materials, and equipment types in chemical process industries (CPI) [6]. However, after a detailed analysis, we note that six process safety assessment methods, including inherent safety and risk assessment methods, are suitable to evaluate process safety based on the P&ID. The method selection is based on the parameters involved in the methods that directly relate to the information available from the P&ID. The details and principles of each method used in this study are explained in the methodology section.

**Table 1** Information to be included in constructing Piping and Instrumentation Diagram (P&ID) [7].

<b>Item</b>	<b>Process Information</b>
<b>Equipment</b>	Summary details of each unit Spare units Parallel units
<b>Piping</b>	Major and minor bypass line Sizes (use standard size) Schedule (thickness) Construction materials Insulation (thickness and type)
<b>Instruments</b>	Indicators, recorders, and controllers display instrument lines
<b>Utilities</b>	Entrance utilities Exit utilities Exit-to-waste utilities

As discussed above, many methods and approaches have been developed for assessment of the safety level in different process design stages. However, there are no comprehensive guidelines on safety assessment that have the ability to guide or assist the user in selecting an appropriate method based on time and budget constraints, data availability, target of assessment, and expected accuracy of the final results. Therefore, the main goal of this research was to propose a systematic framework and comprehensive guidelines for safety evaluation and mitigation strategies based on data available in the P&ID. By using a heuristic framework that acts as a guideline, any hazard present should be minimized or eliminated. In addition, it can expedite projects directly and

benefit the analyzer indirectly. Apart from that, early hazard and risk assessment allows early planning for strategies and engineering controls to either eliminate hazards or mitigate their consequences.

The remaining section of this paper is organized as follows: the guidelines on how to select an appropriate safety assessment method and hazard or risk minimization strategy are explained in detail in the following section. After that, a P&ID-based case study is presented to illustrate the proposed framework. Finally, the conclusion and future work are given.

## 2 Methodology

Before presenting the developed framework, a brief description of the systematic organization of this study is given in the following sub-sections. Well-ordered steps were constructed, starting from reviewing and classifying available process safety assessment methods until the stage of demonstrating the framework in a case study as summarized in Figure 1.

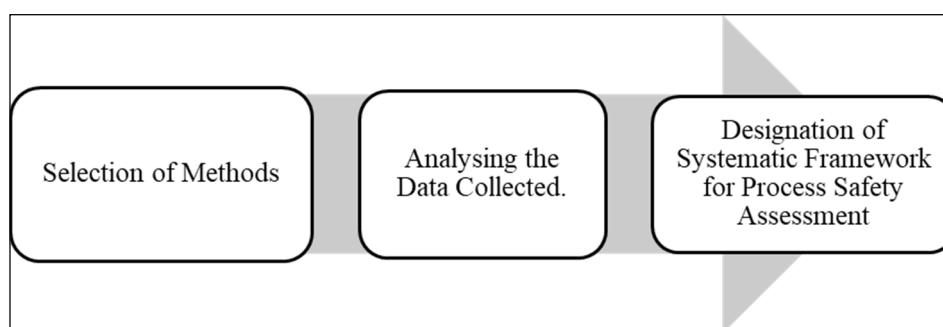

Figure 1 Overall research methodology steps.

### 2.1 Selection of Methods

In this work, seven safety assessment approaches, mainly index-based, were selected to be included in the framework. In order to understand the correlation between the methods, their basic elements were analyzed. Table 2 summarizes the information used for each assessment. Note that each index uses different parameters for assessment. Therefore, it is important for users to identify the required information for assessment based on their interest, data availability, time constraints as well as assessment scope. As can be seen from Table 2, the evaluation of hazard and risk assessment can be made more focused or more extensive based on the information items generated from the P&ID, which cover process piping and fittings, mechanical equipment as well as valves, etc.

A detailed discussion of the information used in each method can be found in Section 3.

**Table 2** Information (parameters) used in index methods.

Safety Data Needed		DOW	DOW	HIRA		SWe	I2SI
		FEI	CEI	FEDI	TDI	HI	
Process conditions	Temperature	/	/	/	/	/	/
	Pressure	/	/	/	/	/	/
Fire and explosion	Flash point			/		/	
	Fire point			/		/	
	Auto-ignition temperature			/		/	
	NF	/		/		/	
Toxicity	Threshold limit value (TLV)						
	NH				/	/	
Reaction and decomposition	Heat of reaction	/		/		/	
	NR	/		/		/	
Inventory	Mass balance	/	/	/	/	/	/
Equipment or unit operation	Equipment dimensions (height, length, diameter)		/	/		/	/
	Construction material	/		/		/	/
Piping	Pipe dimensions (diameter, thickness, radius, area)		/	/		/	/
	Instrument systems	/	/				/
Others	Safety systems	/	/			/	/
	Preliminary design layout	/	/	/	/	/	
	Preliminary human population data				/	/	/

**Table 3** Characteristics of index-based methods.

Ref. No.	Type of Assessment	Hazard to be Assessed	Outcome of Assessment (Depend Variable)
[8,9]	Semi quantitative	Fire & explosion	<ul style="list-style-type: none"> <li>i. Magnitude of hazard that would result from an incident in a process plant.</li> <li>ii. Damage factor that represents the overall effect of fire plus damage resulting from a release of flammable or combustible material.</li> </ul>
[8,10]	Quantitative	Toxicity	<ul style="list-style-type: none"> <li>i. Ranking the process unit based on the magnitude of hazard.</li> <li>ii. Airborne quantity of liquid and vapor release.</li> <li>iii. Radius of exposure determined in feet or meters.</li> </ul>
[6,9]	Semi quantitative	Toxicity	<ul style="list-style-type: none"> <li>i. Damage radius of the area getting affected by toxic load.</li> <li>ii. Magnitude of hazard that would result from an incident in a process plant.</li> <li>iii. Ranking the process unit based on the magnitude of hazard.</li> </ul>
[6,9]	Semi quantitative	Fire & explosion	<ul style="list-style-type: none"> <li>i. Damage radius of the area getting affected by considering physical operation units, chemical reaction units, transportation units and others hazardous units.</li> <li>ii. Magnitude of hazard that would result from an incident in a process plant.</li> <li>iii. Ranking the process unit based on the magnitude of hazard.</li> </ul>
[9,11]	Semi quantitative	Fire, explosion & toxicity	<ul style="list-style-type: none"> <li>i. Damage radius of the area getting affected by flammable material and toxic load.</li> <li>ii. Ranking the process unit based on the magnitude of hazard.</li> </ul>
[9,12]	Semi quantitative	Fire, explosion & toxicity	<ul style="list-style-type: none"> <li>i. Damage radius of the area getting affected by flammable material and toxic load.</li> </ul>

Table 3 summarizes the characteristic of the selected index-based methods. It is noted that the selected methods are mainly semi-quantitative and quantitative

methods. Quantitative methods are able to provide numerical values for evaluating and analyzing the relationships between independent and dependent variables in detail. As a result, the user is able to establish cause and effect at the end of the assessment. Meanwhile, a semi-quantitative method is used when the parameters cannot be quantified, whereas opinions based on information that has already been gathered are acceptable. The second characteristic of the methods included in this study refers to the types of hazard to be assessed by each method. Basically, there are three common hazards in chemical industries, i.e. fire, explosion and toxicity. There are methods that only focus on one hazard (e.g. F&EI and CEI) but most of them cover all types of hazard (e.g. HIRA-TDI, HIRA-FEDI, SWeHI and I2SI).

In addition to that, different methods have different ways of determining the margin of safety in a particular process. Therefore, the last characteristic of the index-based methods to be investigated in this work is the outcome of the assessment. This refers to the effect of dependent variables. As can be seen from Table 3, it is apparent that most of the methods have the ability to rank a process unit based on the level of hazard. Apart from that, most of the methods are formulated to determine whether a particular design is safe or unsafe, except CEI. This can be done by evaluating the damage radius, which refers to the hazard distance that is affected by the process unit.

## **2.2 Designation of Systematic Framework for Process Safety Assessment**

In this work, well-ordered steps describing the scenario of this study are presented to illustrate the proposed framework, as shown in Figure 2. Figure 2 shows the framework for process safety assessment based on different types of process information. Technically, this framework is an extension of the hazard identification and risk assessment procedure from the *Guidelines for Hazard Evaluation Procedures* [13]. According to the *Guidelines for Hazard Evaluation Procedures*, the assessment starts with interpreting the process background or operation unit by gathering extensive information pertaining to the equipment or process of interest. This is essential because if data on the applicable equipment or process are not available, then risk assessment cannot be fully applied. Therefore, in making a comprehensive framework, the information can be classified into three forms, i.e. chemical and process properties (MSDS), PFD data, and P&ID data, according to the design stages, as shown in Table 4. Note that in order to perform P&ID-based assessment, the chemical and process properties as well as the PFD data must be available.

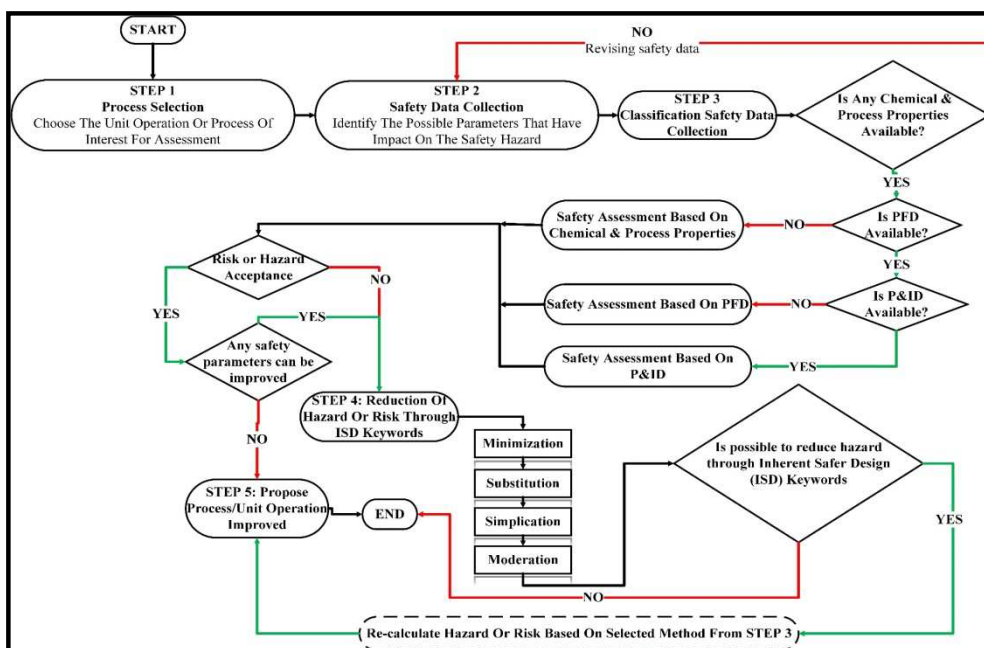

**Figure 2** Framework for process safety assessment based on different types of process information.

**Table 4** Process information in different design stages.

Research & Development Design Stage	Preliminary Process Design Stage	Basic Engineering Design Stage
	All data from the R&D stage	
	PFD	
BFD	Major unit operations	All data from R&D and preliminary stage
MSDS	Operating conditions	P&ID
Reaction steps	Mass & energy	Data on process design of equipment and piping system
Reaction conditions	Simulation data	Preliminary layout design
Stoichiometric equation	Data on preliminary equipment sizing	Utilities design
Product yield	Preliminary selection of construction material	Design of process transfer equipment
Reaction rate	Selection of process transfer equipment (pump, valve)	
Types of chemicals	Preliminary site selection	

An important step in the hazard and risk evaluation procedure as shown in Figure 1 is risk acceptance. This is extended by introducing the ISD keywords



for hazard and risk reduction: i) minimization, ii) substitution, iii) moderation, and iv) simplification. In case it is impossible to reduce the hazard or risk through these keywords, re-assessment towards the process or operation unit can be conducted by revising the process safety information. Otherwise, once the assessment is done for a given process or selected operation unit, the same steps are repeated for the other operation units. The details of the assessments methods as well as their mitigation strategies are discussed in the following section.

### **3 Comprehensive Guideline for Hazard and Risk Evaluation and Mitigation Strategies based P&ID**

As mentioned in the previous section, all safety data to be assessed are first identified based on the P&ID. This is followed by selecting an appropriate method based on data availability, scope and limitations during assessment. Generally, all methods need to identify and select the operation unit to be assessed before the assessment. Nevertheless, it is clear that different methods have different ways of evaluating the safety hazards. Therefore, seven methods are preferred to be included in this stage, which deal with the piping process and equipment level. Most of these methods are tailored to determine whether a particular design is safe or unsafe, except CEI. CEI is formulated to evaluate the quantity of toxic release in the form of liquid or gas. Generally, a detailed assessment of the three major hazards in chemical industries (fire, explosion and toxic release) can be performed during this stage, which leads to a more comprehensive result. Still, each method has its own capabilities in assessing hazards; either one hazard (e.g. toxic release only) or a combination of hazards. There are 4 out of the 7 methods that only focus on one hazard, i.e.: F&EI and FEDI (fire and explosion hazard); and CEI and TDI (toxic release). Meanwhile, three other methods, SWeHI, I2SI and HIRA, cover all types of hazards. Nonetheless, each of them has different criteria in performing safety assessment and has its own limitations. In F&EI, the estimation of penalties for determining the index value are independent on the process unit, whereas in FEDI the estimation of penalties depends on the operation unit type. Apart from that, the input data for FEDI require preliminary plant layout data such as the distance between operation units, which makes it more comprehensive compared to F&EI. For CEI and TDI, both methods measure the toxicity level by calculating the hazard distance (meters). TDI includes data on population density, which cannot be easily obtained during this stage. An expert is needed to decide the population number used in the calculation of TDI based on experience with similar site characteristics. Therefore, CEI is easier to use for assessing the toxicity level compared to TDI. As for the last three methods in this stage, HIRA, SWeHI and I2SI, the similarities between these methods can be seen

from their capabilities in assessing the three major hazards in chemical process industries mentioned before. On the other hand, there are also significant differences between these methods. In SWeHI, the values of fire, explosion and toxicity hazard are compared and a higher value is given more priority for further assessment. Meanwhile, in HIRA and I2SI, the values of fire, explosion and toxicity hazard are considered in order to allocate the rank of the process unit to be evaluated. In other words, users of SWeHI are able to decide which hazard should be prioritized, either fire, explosion or toxicity, before they perform mitigation strategies through ISD keywords. Unlike HIRA, SWeHI and I2SI take into consideration all control measures during their assessment. It can be said that SWeHI and I2SI are more systematic and reliable methods since they take into account a larger number of parameters for hazard quantification compared to HIRA. A detailed explanation of the scope, the parameters affected during assessment, and the output data of each method is given in the following paragraph.

The Fire & Explosion Index (FE&I) provides a comprehensive assessment to determine the areas of greatest loss potential in a particular process or operation unit. At the beginning of the assessment, the material factor (MF) is determined based on the reactivity hazard rating (NF) and flammability hazard rating (NR), which can be obtained from MSDS. Next, the process unit hazard factor (F3) is calculated. The value of F3 is computed based on the general process hazard factor (F1) and special process hazard factor (F2). The general process hazard comprises six factors that can affect the safety level of the process unit examined in the assessment. The six listed factors are the most commonly occurring process conditions based on past incidents. For example, exothermic chemical reaction is the first factor to be estimated for factor F1. This factor is determined based on four classes of exotherms, i.e. *mild*, *moderate*, *critical* and *particularly sensitive*. In case a process reaction in a process unit is found in one of these classes, a penalty value for that class is allocated to that process unit. Note that this factor can only be assigned to reactors. In addition, evaluation of F2 should be conducted to evaluate the safety risk due to specific process conditions. Thus, there are 12 factors that can contribute to major fire and explosions incidents. It is noted that the penalty for each process condition is determined based on criteria for chemical and process conditions. For instance, since toxicity is an inherent property of a material, according to the F&EI guide, the first factor for special process hazard assessment that should be evaluated is the toxic material factor. The penalty for this factor is determined based on the toxicity hazard rating (NH). For other factors we refer to the Dow guide. Note that the higher the hazard level a process unit receives, the higher the penalty. Besides that, the penalty value is ignored if no hazard exists in the process unit. After that, the process unit hazard, F3, is obtained by multiplying F1 and F2.

Finally, MF is multiplied by F3 to determine the F&EI value for the process unit.

The Chemical Exposure Index (CEI) is a simple method that provides a rating for toxicity hazard and hazard distance by evaluating the quantity of toxic release in the form of liquid or gas. Initially, the Emergency Response Planning Guideline (ERPG) value is identified from MSDS. This value refers to the estimation of the concentration of a material (chemical) from which people may experience health effects if they are exposed to it for 1 hour. Meanwhile, airborne quantity (AQ) is calculated based on types of release, whether in the form of liquid or gas. For gas form, the estimation of AQ can be directly obtained based on temperature, pressure and pipe diameter of the process. In addition, the chemical and physical properties of the substances involved such as molecular weight and physical state are also considered in determining AQ. In the event of liquid release in the process, the evaluation of AQ starts by calculating the liquid release rate (L) based on the process conditions. The assessment is continued with the determination of the total liquid release rate (WT), which contributes to pool formation. Next, it has to be established whether the temperature under which the operation takes place is lower than the boiling point of the substances involved. In case the operating temperature is higher than the boiling point, the flash fraction (fv) is calculated based on latent heat vaporization (CP/CV), operating temperature and the boiling point of the substances. Thus, the assessment is continued directly by determining the value of AQf resulted from the flash fraction. In contrast, the pool area (Ap) is determined in case the operating temperature is lower than the boiling point of the substances involved. Note that Ap is affected by the density of the substances and the total liquid release rate (WT). After that, the AQp of the pool surface is calculated by considering the pool area, molecular weight, vapor pressure of the liquid, and pool temperature. It should be noted that pool formation is affected by the release of liquid at operating temperature lower than the boiling point. This scenario can occur in process piping as well as equipment. The AQ value for pool formation is the summation of AQf and AQp. For a detailed explanation of the calculation of AQ for liquid and gas form, we refer to the *Chemical Exposure Index (CEI) Guide* published by the American Institute of Chemical Engineers (1994). Note that since the maximum CEI value is 1000, if the calculated CEI is higher than 1000, CEI is set to 1000.

The Hazard Identification and Ranking System (HIRA) is combination of two indices, the Fire and Explosion Damage Index (HIRA-FEDI) and the Toxic Damage Index (HIRA-TDI). The scope of the assessment by HIRA-FEDI is to quantify the damage radius in the event of fire and explosion hazard. In quantification of HIRA-FEDI, the first step is classifying the process units into five classes based on their mode of operation: storage units, physical operations

units, chemical reactions units, transportation units, and other units that may be harmful. To evaluate the HIRA-FEDI value for these respective units, three energy factors have to be determined. F1 represents chemical energy, while F2 and F3 represent physical energy. The assessment is continued for each type of unit. Note that each class unit has different parameters that can be affected in that unit. For instance, the evaluation HIRA-FEDI for storage units is affected by temperature, pressure, location of nearest hazardous unit, quantity of chemicals, characteristics of chemicals, and density of units. Each parameter is assigned its own penalties based on the particular scenario. For example, the penalties of temperature for storage units is determined based on operating temperature, auto-ignition temperature, flash point, and fire point. Thus, the value of HIRA-FEDI is computed based on energy factors and penalties. In contrast, HIRA-TDI provides measurements in terms of the radius of the area that will be affected by toxic release. Factor G is first determined by considering the mass flowrate and release condition of the substances. The assessment is continued by assigning penalties for other parameters that may contribute to toxic release, such as rupture, leak and spill. These parameters comprise operating temperature, operating pressure, vapor density, toxicity of chemicals, and site characteristics. Finally, factor G and penalties are combined to obtain the HIRA-TDI value. A detailed calculation of HIRA-FEDI and HIRA-TDI can be found in the original work by Khan and Abbasi (1998a) in [6].

The Safety Weighted Hazard Index (SWeHI) is an extension of HIRA with additional safety precautions as part of the assessment. Determination of factors B1 and B2 is the first step in this method. B1 represents the fire and explosion hazard evaluation, while B2 represents the toxicity hazard evaluation. Technically, the evaluation of B1 and B2 is similar to HIRA-FEDI and HIRA-TDI. The values of B1 and B2 are compared and the higher value will be chosen as factor B. The assessment is continued by allocating a credit factor based on required safety measures for the process unit. At this step, safety measures are divided into two parts: controlling the damage potential of the individual unit and reducing the frequency of occurrence of unwanted events. In quantification of the credits for controlling the damage potential of the individual unit, three types of control measures are applied, i.e. emergency resource planning (ERP), disaster management plan (DMP), and other control measures. Meanwhile, for reduction of accident frequency, four control strategies are applied: process control system, detection devices, emergency control measures, and human error reduction. A detailed discussion of the quantification of safety measures can be found in the original work of Khan, *et al.* (2001) in [11].

The Integrated Inherent Safety Index (I2SI) was introduced to predict the damage potential of a process by considering process and hazard control measures. Based on this method, both safety and environmental aspects are

taken into consideration. In this work, only safety hazards were evaluated. Thus, only the safety aspect of I2SI is reviewed. Chemical and process data are needed in this method, which can be divided into four groups: i) chemical substances, ii) operating conditions (temperature and pressure), iii) inventory (mass balance), and iv) the process control system. I2SI divides the safety aspect into a hazard index (HI) and an inherent safety potential index (ISPI). The HI is first calculated based on the damage index (DI), which focuses on the flammability and toxicity of the involved substances. Therefore, the chemical properties of each chemical substance are collected. The calculation of the DI is similar to that of HIRA-FEDI for flammability substances. For toxicity substances, HIRA-TDI is applied. The assessment is continued by determining the process hazard and control index (PHCI). The purpose of this sub-index is to evaluate various add-on processes and hazard control systems that are required or already part of the system. The selection of the safety system is based on the requirements of the process unit. Finally, the value of HI is obtained by dividing DI and PHCI. The second step is computation of ISPI by dividing the inherent safety index (ISI) value with PHCI. In order to compute the value of ISI, first a selection of appropriate guidewords based on the needs of the process unit is made. Simultaneously, a selection based on the extent of applicability of each guideword is performed to allocate the PHCI value. The extent of applicability of guidewords is necessary to know for any control system to be added to the process unit. For a detailed explanation, we refer to the original work of Khan and Amyotte in [12].

After allocating all parameters with their individual scores, the last part is comparing the evaluated scores with the respective benchmark value or hazard or risk acceptance. In cases where the risk or hazard value is lower than the benchmark value, the user has to try out all possible combinations of all four ISD keywords to reduce or eliminate the hazard as much as possible. This mitigation strategy is focused on materials as well as process conditions that are less hazardous. Note that alternative process chemistry and chemical substances are not included in this discussion, since most of the chemicals or solvents have already been confirmed and finalized. Therefore, the modifications are focused on the process, operation units, storage tanks and piping system.

1. Minimization can be done by reducing the amount of piping, pipe connectors and gaskets. This can also be done by minimize the number of elbows, tees, valves, fittings and other obstructions in the piping system, while simplifying the layout (P&ID) as much as possible. This can potentially minimize friction losses in the piping system and hence reduce pressure drop as well as velocity. At some point, friction can cause a decrease in pumping pressure and velocity, which adversely affects pumping efficiency. Apart from that, reducing the hole diameter of the

pipework could be another option. By doing this, the amount of released toxic and flammable materials would be minimized.

2. Substitution can be considered for pipes, vessels and pump by replacing their material with an alternative that is able to resist erosion and corrosion. Another common strategy involves using corrosion resistant materials, protective coatings and paints. Moreover, substitution can also be applied by replacing equipment with welded and leak-proof joints and connections to reduce the probability of loss of flammable or combustible material during the process.
3. Moderation can be done by maximizing the use of welded pipes to create more benign conditions by reducing the probability of the occurrence of hazardous conditions such as leaks. Instead of welding, installing fire protective insulation can also be part of a moderation strategy. For example, in case the pump that transfers flammable substances from the reactor to the distillation column fails catastrophically, it would cause the formation of a pool due to the release of a large quantity of flammable material. As a result, the pool surrounding the reactor and distillation column could ignite and form an intense fire. At this point, the only barrier between the surface of the process unit and the fire is the thermal insulation, which acts as a fire-protective insulator. Moderation can also be performed by installing proper drainage to ensure that spills of flammable materials are carried away from the equipment and potential sources of ignition.
4. Simplification is the last mitigation strategy option after performing hazard assessment based on P&ID. This could be performed by combining a number of process operations, leading to fewer transfer operations and less pipework. For instance, in some cases a complex pipework can have a high potential for equipment failure or operation error. Therefore, by simplifying the pipework, the level of hazard in the process may be reduced or minimized.

Overall, these mitigation strategies affect the risk or hazard level by reducing its intensity, energy level, inventory as well as concentration of hazardous substances released into the surroundings. Apart from that, the parameters (dependent variables) of each method influence the outcome of the assessment (independent variables) through these strategies.

#### **4 Case Study: Benzene Distillation Process Design**

A benzene distillation process design was used as a case study to illustrate the applicability of the proposed comprehensive guidelines in conducting safety assessment based on P&ID. The P&ID for the benzene distillation plant is shown in Figure 3. This process involves four chemical substances, i.e. benzene, toluene, methane and hydrogen gas. From a safety point of view, most

of chemical substances in the process are flammable and toxic to varying degrees. However, based on the mass balance provided by Turton, *et al.* [7], benzene is the major component by mass, whereas the rest are minor components. Therefore, benzene was selected for evaluation in this case study. Apart from that, there is a significant number of other safety issues from column malfunction histories based on Kister's surveys [14]. Therefore, based on the information provided by this case study, the Dow Index was deemed to be the most suitable method for evaluating the safety level using P&ID information. All information needed for this assessment was gathered directly from Turton, *et al.* [7]. The results of the assessment are as follows.

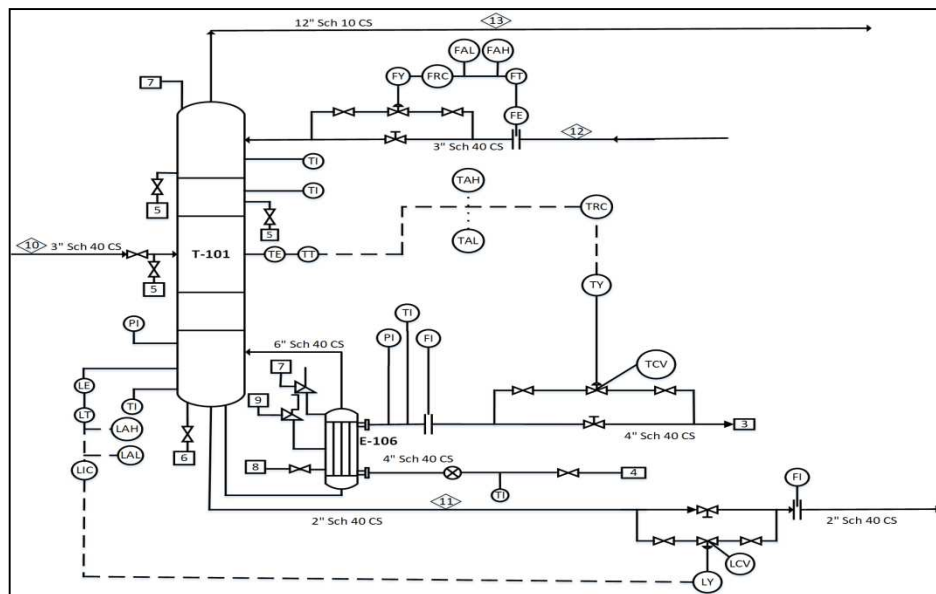

**Figure 3** Piping and instrumentation diagram of benzene distillation process design [7].

In the CEI evaluation, streams 10 and 13, which are connected to the benzene tower (T-101), were selected to illustrate accident scenarios that could occur due to pipe leaking. Consequently, CEI evaluation was performed for liquid as well as vapor release. The ERPG/EEPG values of benzene were first identified, which are already listed in the *CEI Guide*. The ratio of specific heat capacity to vaporization heat ( $C_p/H_v$ ) is unknown. Therefore, based on the recommendation in the *CEI Guide*, 0.0044 was used in this assessment. For the calculation of vapor release, the airborne quantity (AQ) was 47.87 kg/s, based on three dependent variables: the hole diameter of the pipe (304.8 mm), absolute pressure (251.47 kPa), and operating temperature (147 °C). Thus, the

CEI value for vapor release was computed at 207.05. Meanwhile, the hazard distance based on ERPG-2 was 2070.5 m. For the liquid release calculation, one parameter could not be determined from the available information, i.e. the height of the liquid benzene on the tray. Therefore, the height of the liquid benzene on the tray was estimated using the Francis Weir formula, which gave 40.22 mm. Then, the value of AQ was obtained at 114.03 kg/s based on two dependent variables: the hole diameter of the pipe (76.22 mm) and the height of the liquid (40.22 mm). Finally, the CEI value and the hazard distance for liquid release were obtained at 319.56 and 3195.66 m, respectively.

In the F&EI evaluation, the base material was benzene, which is already listed in the FEI database. Therefore, the MF of benzene was set to a value of 16. Then, the value of F1 was evaluated based on the mode of benzene handling and transfer. Hence, by looking at the chemical properties of benzene, class 1 flammability was selected, which was counted as 0.50. Finally, the general process hazard factor, F1, was calculated as 1.50. The computation of F2 is based on five items to be considered in this case study. Firstly, toxic material was evaluated as 0.4 based on the NH value, which was 2. Chemically, benzene is a highly flammable material and it is easily ignited under most ambient temperature conditions. Therefore, the 'process upset' and 'always in flammable range' criteria in the Special Process Hazards section were selected. This yielded a penalty of 1.10 for operation within or near the flammable range. The operating pressure was 43.51 psig, which yielded a penalty of 0.23 for pressure criteria. The penalty for quantity of flammable material was quantified based on the HC factor, which was directly obtained from the FEI database and the quantity of the material. Based on the F&EI database, the value of HC for benzene is  $17.3 \times 10^{-3}$  and the amount of benzene was 439324 lb, which gave a penalty of 0.15. Apart from that, corrosion and erosion issues were also included in the assessment. As a result, a corrosion range of 0.005-0.127 mm/year was chosen, giving a minimum penalty of 0.10. In addition to corrosion and erosion issues, leakage can be another problem occurring in most of the chemical process. Therefore, a minor leak was chosen, which yielded a penalty of 0.1. Another hazard to be included in this assessment was fired equipment. Since a heat exchanger (E-106) is located within the process area and there is a possibility that the material in the process unit could be released above its flash point, a minimum penalty of 0.10 was given. With these data and assumptions, the value of F&EI was obtained at 49.92. Then, the magnitude of the potential hazard was determined based on the rating table from the Dow F&EI guide to allocate the degree of hazard. The FEI value of 49.92 represents the level 'light' as the result of this assessment.

As stated previously, hazard or risk mitigation strategies can be implemented through ISD keywords for improving the safety level of the benzene distillation



plant design. A modification is proposed by minimizing the hole diameter of the piping, which affects the CEI value. In order to illustrate how the minimization strategy was conducted in this case study, the relationship between the hole diameter of the piping and the CEI values for vapor and liquid release are presented in Figure 4(a) and 4(b), respectively. For example, for a pipe diameter of 2 inch (50.8 mm), the CEI value drops to 209.65 for liquid release. It is apparent that the hole diameter has a significant influence on CEI. Apart from that, by reducing the hole diameter, the total amount of benzene ejected would be minimized. This observation is particularly important in the selection of an optimum piping design for processes handling hazardous materials.

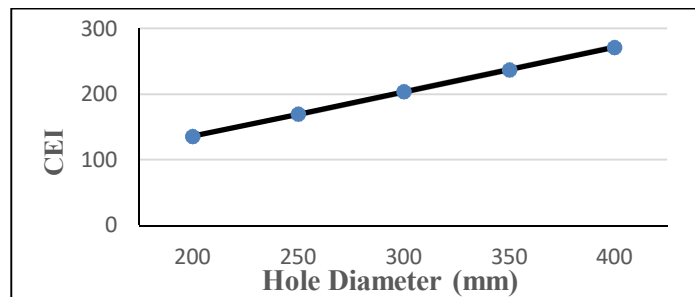

(a)

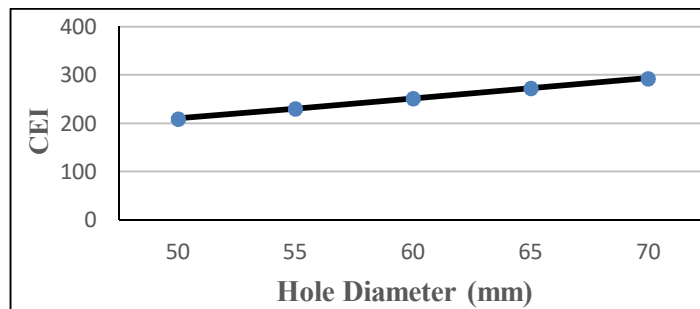

(b)

**Figure 4** Effect of hole diameter on CEI for benzene: (a) vapor release, (b) liquid release.

## 5 Conclusion

This work was devoted to proposing comprehensive guidelines for safety hazard assessment and mitigation strategies based on the P&ID. This was performed by integrating existing safety methods, i.e. index-based approaches that are deemed to be suitable for analyzing safety levels based on the P&ID information. The proposed guideline was proven to be successful in hazard reduction through ISD keywords as shown by our case study. The case study revealed that the developed framework successfully performed its function in determining the

most suitable method for predicting the hazard level of the process to be assessed. The aim of the case study was to determine the magnitude of the hazard that would result from an accident and the radius of exposure in a benzene distillation plant.

The Dow Index (F&EI and CEI method) was selected and compared with other methods (I2SI, SWeHI, HIRA-FEDI, and HIRA-TDI). The magnitude of hazard was determined by using the FEI method, while the radius of exposure was calculated using the CEI method. The calculated FEI value (49.92) was found in the range of the level 'light', which is classified as an acceptable range. However, the calculated CEI value (270) for liquid (benzene) release was found to be higher than the critical CEI value (200). Therefore, among four ISD keywords, minimization was deemed to be the most suitable ISD keyword. This was conducted by reducing the hole diameter of the piping from 76.22 mm to 50 mm, which resulted in a decrease of the CEI value to 177 (within the acceptable range). The reduction of the hole diameter also impacted the hazard distance, decreasing it from 2700 mm to 1770 mm.

This means that the case study confirmed that the developed framework can be used as a guideline for selecting the most appropriate strategy in reducing the hazard level of the process to be evaluated. Other than that, the case study also confirmed that the developed framework can be applied as a decision-making tool in selecting an optimum design of processes handling hazardous materials. It is noticeable that early hazard and risk assessment allows early planning of strategies and engineering controls to either eliminate hazards or mitigate their consequences. Aside from reducing the hazard, the proposed guidelines also proves to be able to provide options to the user in selecting an appropriate method based on the scope, nature, interest, and limitations of his or her assessment. Therefore, the project can be expedited directly and benefit the analyzer indirectly. Apart from that, the developed framework can be used as a tool to prevent major accidents in chemical process industries, as part of seven core concepts to prevent major accidents, as stated by Amyotte in [15]. To enhance the applicability of the proposed guidelines, the PFD and a detailed plant layout can be included in a future work in order to extend these guidelines to cover all chemical process design stages.

### **Acknowledgement**

The financial support from the Ministry of Higher education, Malaysia through the LRGs Grant (project code: LRGs/2013/UKM-UNMC/PT/05) is gratefully acknowledged.

### **References**

- [1] Mannan, M.S., Sachdeva, S., Chen, H., Reyes-Valdes, O., Liu, Y. & Laboureur, D.M., *Trends and Challenges in Process Safety*, AIChE Journal, **61**(11), pp. 3558-3569, 2015.
- [2] Kidam, K., Sahak, H.A., Hassim, M.H., Shahlan, S.S. & Hurme, M., *Inherently Safer Design Review and Their Timing during Chemical Process Development and Design*, Journal of Loss Prevention in the Process Industries, **42**, pp. 47-58, 2016.
- [3] Kletz, T.A. & Amyotte, P., *Process Plant: A Handbook for Inherently Safer Design*, (Second Edition), 2010.
- [4] Taylor, J.R., *Understanding and Combating Design Error in Process Plant Design*, Safety Science, **45**(1-2), pp. 75-105, 2007.
- [5] Shariff, A.M. & Leong, C.T., *Inherent Risk Assessment – A New Concept to Evaluate Risk in Preliminary Design Stage*, Process Safety and Environmental Protection, **87**(6), pp. 371-376, 2009.
- [6] Khan, F.I. & Abbasi, S., *Multivariate Hazard Identification and Ranking System*, Process Safety Progress, **17**(3), pp. 157-170, 1998.
- [7] Turton, R., Bailie, R.C., Whiting, W.B. & Shaeiwitz, J.A., *Analysis, Synthesis and Design of Chemical Processes*, Pearson Education, 2008.
- [8] Khan, F., Rathnayaka, S. & Ahmed, S., *Methods and Models in Process Safety and Risk Management: Past, Present and Future*, Process Safety and Environmental Protection, **98**, pp. 116-147, 2015.
- [9] Khan, F.I. & Abbasi, S.A., *Techniques and Methodologies for Risk Analysis in Chemical Process Industries*. Journal of Loss Prevention in the Process Industries, **11**(4), pp. 261-277, 1998.
- [10] Etowa, C.B., Amyotte, P.R., Pegg, M.J. & Khan, F.I., *Quantification of Inherent Safety Aspects of the Dow Indices*, Journal of Loss Prevention in the Process Industries, **15**(6), pp. 477-487, 2002.
- [11] Khan, F.I., Husain, T. & Abassi, S.A., *Safety Weighted Hazard Index (Swehi) A New, User Friendly Tool for Swift yet Comprehensive Hazard Identification and Safety Evaluation in Chemical Process Industries*. Trans IChemE, **79**, 2001.
- [12] Khan, F.I. & Amyotte, P.R., *Integrated Inherent Safety Index (I2SI): A Tool for Inherent Safety Evaluation*, Process Safety Progress, **23**(2), pp. 136-148, 2004.
- [13] Crowl, D.A. & Louvar, J.F., *Chemical Process Safety: Fundamentals with Applications*, Pearson Education, 2001.
- [14] Kister, H.Z., *What Caused Tower Malfunctions in the Last 50 Years?* Chemical Engineering Research and Design, **81**(1), pp. 5-26, 2003.
- [15] Amyotte, P.R., Berger, S., Edwards, D.W., Gupta, J.P., Hendershot, D.C., Khan, F.I., Mannan, M.S. & Willey, R.J., *Why Major Accidents are still Occurring*, Current Opinion in Chemical Engineering, **14**, pp. 1-8, 2016.