

THE MEASUREMENT OF COMPACTION THROUGH FIELD DENSITY TEST  
IN THE EMBANKMENT PIT STRATA

MOHD HAFIZ BIN SHAFIE

A project report submitted in partial fulfillment of the  
requirements for the award of the degree of  
Master of Engineering (Civil – Geotechnics)

Faculty of Civil Engineering  
Universiti Teknologi Malaysia

DECEMBER 2015

***“ Dengan Nama Allah SWT Yang Maha Pemurah Lagi Maha Penyayang ”***

*To my lovely wife, parents and family for their patience and support during my study  
at UTM.*

## ACKNOWLEDGEMENTS

It is a great pleasure to address those people who helped me throughout this project to enhance my knowledge and practical skills especially in research area. My deepest and most heartfelt gratitude goes to my supervisors, Assoc. Prof. Dr. Hisham Mohamad. The continuous guidance and support from him has enabled me to approach work positively, and make even the impossible seem possible.

I wish to express my special thanks to my beloved wife, parents, family and all my friends who gives me spirit, support and encouragement to me in completion this project.

Many thanks to my company Advancecon Infra Sdn. Bhd. for giving me chance to pursue my study.

Finally, thanks to all my classmates for their helped and support. I would also like to thank everyone who has contributed whether directly or indirectly to this project. This project would have been impossible without your guidance, advice and support.

Thank you...

## ABSTRACT

The soil should have sufficient strength, be relatively incompressible so that future settlement will not be excessive, maintain a constant volume change against variable water content or other factors, be resistant to deterioration, and possess proper permeability. Standard test had been introduced to determine the compaction percentage especially at the embankment area. In the current practice in the construction industry, the Field Density Test (FDT) Sand Replacement is the best method in term of result obtained at the economic cost. The method has limitation of the scope which the test normally to be carry on the surface layer after the soil layer leveled and compacted. When the test is carried out in the embankment, the moisture content of soil will be effected the compaction value of the soil layer. To overcome this issue, some testing had been undertaken at the vicinity of cut ground area with the same method carried in the embankment area. In addition, the percentage of consolidation of soft soil under the embankment and strength characteristic of the embankment layer had been considered. The result showed that the cut ground obtained high moisture content average 28% higher the Optimum Moisture Content (OMC) and consequently resulting to a lower range of 90% compaction. On the other hand, the consolidation percentage of soft soil under the timeframe showed 82% and 85% at selected point respectively. Moreover, the embankment layer showed at the condition of stiff layer based on the Mackintosh Probe (MP) test carried out at the area. From the result it has been concluded that the adopted test is incorrect due to effect of the high moisture content in the soil. The consolidation process occurring and affect the micro crack in the embankment even though the soil layer in the embankment is stiff layer.

## ABSTRAK

Tanah harus mempunyai kekuatan yang mencukupi supaya penyelesaian tanah ketidakboleh mampatan dianggap tidak akan berlebihan, mengekalkan perubahan isipadu malar terhadap kandungan air yang berubah-ubah atau faktor-faktor. Ujian Standard telah diperkenalkan untuk menentukan peratusan pemadatan dan di kawasan tambakan. Dalam amalan semasa industri pembinaan, Ujian Ketumpatan Tanah (FDT) iaitu Penggantian Pasir adalah kaedah terbaik dari segi hasil yang diperoleh pada kos yang ekonomi. Kaedah ini mempunyai had skop ujian iaitu dijalankan pada lapisan permukaan selepas lapisan tanah tersebut diratakan dan dipadatkan. Apabila ujian dijalankan didalam kawasan tambakan, kandungan kelembapan tanah akan mempengaruhi nilai pemadatan lapisan tanah tersebut. Untuk mengatasi masalah ini, beberapa ujian telah dijalankan di kawasan tanah potong dengan kaedah yang sama dijalankan di kawasan tambakan. Di samping itu, peratusan mampatan tanah lembut dibawah tambakan dan kekuatan ciri setiap lapisan tanah tambakan turut dipertimbangkan. Hasilnya menunjukkan bahawa tanah kawasan potong yang diperolehi mempunyai kandungan air yang tinggi dengan purata 28% iaitu lebih tinggi Kandungan Lembapan Optimum (OMC) dan seterusnya kekuatan tanah lebih rendah daripada 90% pemadatan. Sebaliknya, peratusan mampatan tanah lembut di bawah tempoh masa yang ditetapkan menunjukkan 82% dan 85%. Selain itu, setiap lapisan tanah tambak menunjukkan tanah berkeadaan keras berdasarkan Mackintosh Probe (MP) Ujian dijalankan di kawasan itu. Daripada hasil yang ia telah dibuat, kesimpulannya bahawa ujian yang digunakan adalah tidak betul kerana kesan kandungan lembapan yang tinggi di dalam tanah mempengaruhi peratusan pemadatan tanah. Proses mampatan yang masih berlaku akan sedikit sebanyak memberi kesan retak mikro di dalam tanah tambakan walaupun lapisan tanah di tambak adalah lapisan keras.

## TABLE OF CONTENTS

<b>CHAPTER</b>	<b>TITLE</b>	<b>PAGE</b>
	<b>DECLARATION</b>	<b>ii</b>
	<b>DEDICATIONS</b>	<b>iii</b>
	<b>ACKNOWLEDGMENTS</b>	<b>iv</b>
	<b>ABSTRACT</b>	<b>v</b>
	<b>ABSTRAK</b>	<b>vi</b>
	<b>TABLE OF CONTENTS</b>	<b>vii</b>
	<b>LIST OF TABLES</b>	<b>x</b>
	<b>LIST OF FIGURES</b>	<b>xi</b>
	<b>LIST OF SYMBOLS</b>	<b>xiii</b>
	<b>LIST OF APPENDICES</b>	<b>xiv</b>
<b>1</b>	<b>INTRODUCTION</b>	<b>1</b>
	1.1 Background of Study	1
	1.2 Problem Statement	3
	1.3 Objective	6
	1.4 Scope Of Works	6
	1.5 Significance of Study	7
<b>2</b>	<b>LITERATURE REVIEW</b>	<b>9</b>
	2.1 Field Density Test (FDT)	9
	2.1.1 Definition	9
	2.1.1 Apparatus	10
	2.1.2 Procedure	12

2.1.4	Calculation	15
2.2	Compaction	17
2.2.1	Definition	17
2.2.2	Factor Effect on Compaction	18
2.2.2.1	Compaction Effort	19
2.2.2.2	Moisture Content	20
2.2.2.3	Soil Type	21
2.2.2.4	Layer Thickness	21
2.2.2.5	Contact Pressure	21
2.2.3	Types of Compaction Tests	22
2.3	Pre-loading Method	26
2.2.4	Definition	26
2.2.5	Types of Pre-loading	27
2.2.6	Factor Effects On Pre-loading	30
2.4	Cone Penetration Test	34
2.5	Degree of Consolidation	37
<b>3</b>	<b>RESEARCH METHODOLOGY</b>	<b>39</b>
3.1	Introduction	39
3.2	Literature Research	40
3.3	Data Collection	41
3.3.1	Soil Testing Preparation	41
3.3.2	Apparatus	44
3.3.2.1	Calibration of Apparatus	46
3.3.2.2	Field Density measurement	47
3.4	Analysis of Data	51
<b>4</b>	<b>CASE STUDY OF EMBANKMENT</b>	<b>53</b>
4.1	Introduction	53
4.2	General Description of Project	53
4.3	Preparation of Embankment	56
4.4	Soil Test onto Platform Area	59
4.5	Subsoil Condition	66
4.6	Settlement Monitoring Result	71

<b>5</b>	<b>RESULT OF ANALYSIS AND DISCUSSIONS</b>	<b>74</b>
	5.1 Introduction	74
	5.2 Analysis of Compaction Percentage	75
	5.2.1 Embankment Compaction Percentage	75
	5.2.2 Cut Ground Compaction Percentage	78
	5.3 Settlement Analysis	79
	5.4 Degree of Consolidation	81
	5.5 Soil Layer in the Embankment Area	81
<b>6</b>	<b>CONCLUSION AND RECOMMENDATION</b>	<b>83</b>
	6.1 Introduction	83
	6.2 Conclusion	83
	6.3 Recommendation for Further Studies	84
	<b>REFERENCES</b>	<b>86</b>
	<b>APPENDICES A - B</b>	<b>87-93</b>



**LIST OF TABLES**

<b>TABLE NO.</b>	<b>TITLE</b>	<b>PAGE</b>
2.1	Types of vertical drain (Stapelfeldt, 2010)	32
4.1	Relative compaction result at embankment area	62
4.2	Relative compaction result at cut ground area	64
4.3	Mackintosh Probe (MP) result at tested point area	65
4.4	Profile of typical soft soil of the project area	66
4.5	Engineering properties of soft soil at project area	67

## LIST OF FIGURES

<b>FIGURE NO.</b>	<b>TITLE</b>	<b>PAGE</b>
1.0	Core Cutter Method	3
1.1	Sand Cone Test	4
1.2	500 mm thickness each step for FDT	5
1.3	The pit showed the line of moisture content is high	6
2.1	Cone-Cutter Test Apparatus (Soil Engineering Sectional Committee, 2007)	11
2.2	Smooth Wheel Roller	20
2.3	One- Point T-99 Test and AASHTO T-99 Test (ITD, 2014)	24
2.4	One- Point Michigan Cone Test and Michigan Cone Test (ITD, 2014)	24
2.5	Michigan Modified T-180 Test (ITD, 2014)	25
2.6	Nuclear Density In-Place Test (ITD, 2014)	25
2.7	Conventional Pre-loading of subsoil (Stapelfeldt, 2010)	28
2.8	Resulting settlement due to pre-loading	29
2.9	Vacuum system (Stapelfeldt, 2010)	30
2.10	Pre-loading with vertical drains (Stapelfeldt, 2010)	31
2.11	Manufacturing and operating tolerances of cone (David, 2006)	35
2.12	Traditional method of site investigation	36
3.1	Flowchart of Methodology	40
3.2	500 mm thickness each step for FDT	42
3.3	Formation of step stair 500 mm thickness at cutting area	43
3.4	Formation of step stair 500 mm thickness at embankment	

	area	43
3.5	Pouring cylinder and electrical balancing	45
3.6	Pouring cylinder, metal plate and hand tool for FDT	45
3.7	Field density test carried out in the embankment pit area	48
3.8	Field density test carried out at the cutting ground area	48
3.9	Excavated material put in the plastic bag before send to laboratory	49
4.1	Site location	55
4.2	Project layout plan	55
4.3	Soft soil profiles at the project site area	56
4.4	Case study were focused on the Glade 1 treatment area	57
4.5	Location of settlement gauge for settlement monitoring	59
4.6	Five locations are selected to carry out the soil test	60
4.7	Step down with 500 mm thick were formed	61
4.8	Field Density Test (FDT) was carried out at every step	61
4.9	Red cloud shows the location selected at cut area	63
4.10	Mackintosh Probe (MP) tests carried out at the platform surface	65
4.11	Moisture content and bulk density versus depth	67
4.12	Clay, silt and sand content versus depth	68
4.13	Atterberg limit results from laboratory testing	69
4.14	Compressibility parameter versus depth	70
4.15	Preconsolidation pressure versus depth	70
4.16	Location of settlement gauge for settlement monitoring	71
4.17	Settlement gauge monitoring for SG42	72
4.18	Settlement gauge monitoring for SG55	73
5.1	Compaction percentage every depth in the embankment area	76
5.2	Higher moisture content of soil identified during the test	76
5.3	The sand blanket at the bottom of soil embankment	77
5.4	Compaction percentages every depth at cut ground area	79
5.5	Total settlement graph for SG42	80
5.6	Total settlement graph for SG55	80
5.7	Graph blows per 300 mm versus reduced level	82

**LIST OF SYMBOLS**

$A$	-	Air content
$G_s$	-	Specific gravity
$M$	-	Mass of wet soil
$M_s$	-	Mass of dry soil
$M_w$	-	Mass of water
$\rho_b$	-	Bulk density
$\rho_d$	-	Dry density
$\rho_w$	-	Water density
$V$	-	Volume of mould
$w$	-	Moisture content
$\gamma_b$	-	Bulk density

**LIST OF APPENDICES**

<b>APPENDIX</b>	<b>TITLE</b>	<b>PAGE</b>
A	FDT Result at Embankment Area	88
B	FDT Result at Cut Ground Area	94

## **CHAPTER 1**

### **INTRODUCTION**

#### **1.1 Background of Study**

Soil is extensively utilized as a basic material of construction, as witnessed by the existence of earth structure such as dams and road embankments. In these cases, it is desirable that the soil used as in-place material possess reliable properties. The soil should have sufficient strength, be relatively incompressible so that future settlement will not be excessive, maintain a constant volume change against variable water content or other factors, be resistant to deterioration, and possess proper permeability.

The requirements can best be achieved by a precise selection of fill material type and proper placement application. The essential properties of a fill can be checked independently, however, desirable characteristics, such as high strength, low compressibility, and stability, are normally associated with density (or unit weight) values that can be fastened through good compaction.

When soil is used for construction purposes, either in embankments or in pavement subgrades, it is distinctively layered to form the final shape. Obviously, each layer is compacted before being covered with the following layer. After proper placement and compaction, the resulting soil mass has the strength and bearing capabilities that are as good as or better than many natural soil formations.

To evaluate the degree of compaction, it is common to check soil zones using the in-situ density (or in-situ unit weight) test procedure. Typically, each compacted layer is checked at random locations. Placement of the next layer begins only after tests indicate a satisfactory compaction level. Therefore, field tests should be well understood and carefully assessed to ensure correct construction.

The dry density of the compacted soil or pavement material is a common measure of the amount of the compaction achieved during the construction stage. Knowing the field density and field moisture content at the site, the dry density is calculated. Therefore, field density test is importance thing as a field control test for the compaction of soil or any other pavement layer.

There are several methods for the determination of field density of soils such as sand replacement method, core cutter method, heavy oil method, rubber balloon method etc. One of the common methods of determining field density of fine-grained soils in engineering industry is core cutter method; but this method has a major limitation in the case of soils containing coarse-grained particles such as gravel, stones and aggregates. Under such circumstances, field density test by sand replacement method is an advantageous, as the presence of coarse-grained particles will adversely affect the test results.

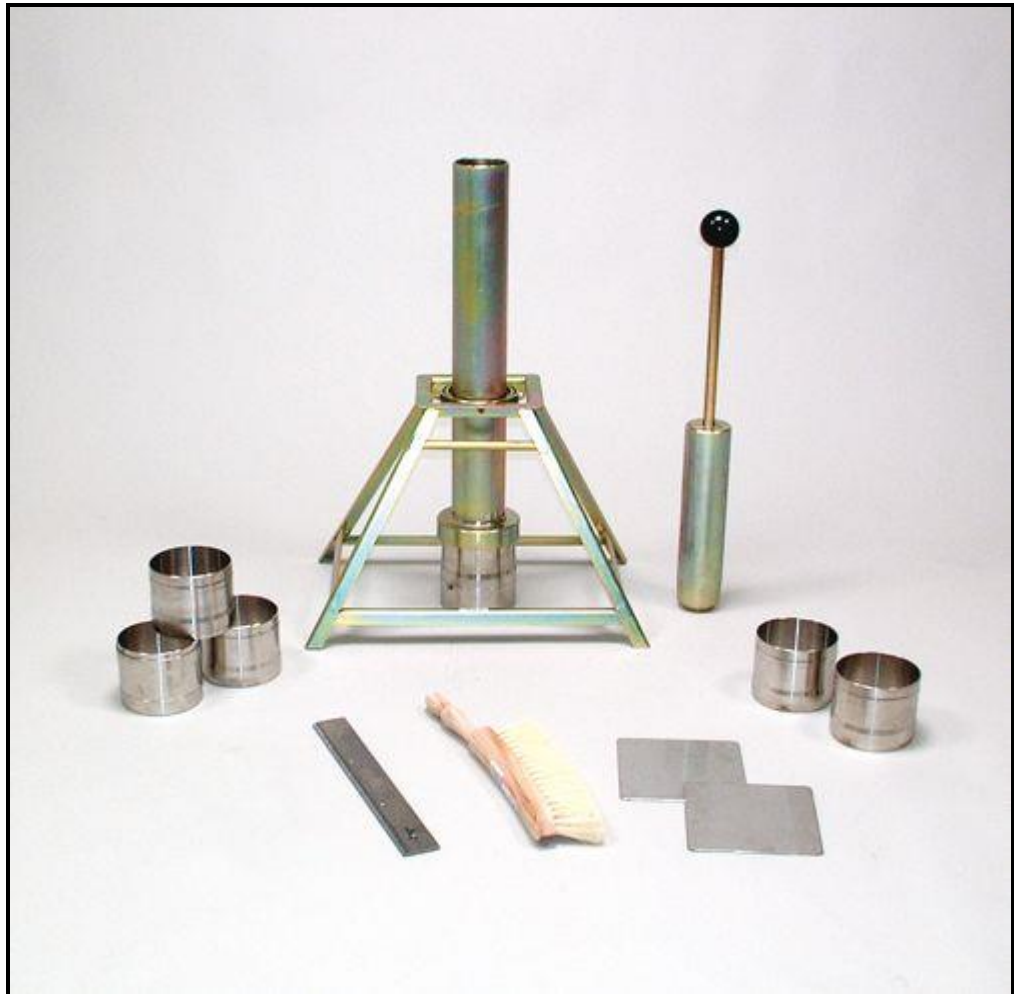

**Figure 1.0:** Core Cutter Method

The basic principle of sand replacement method is to measure the in-situ volume of hole from which the material was excavated from the weight of sand with known density filling in the hole. The in-situ density of material is given by the weight of the excavated material divided by the in-situ volume



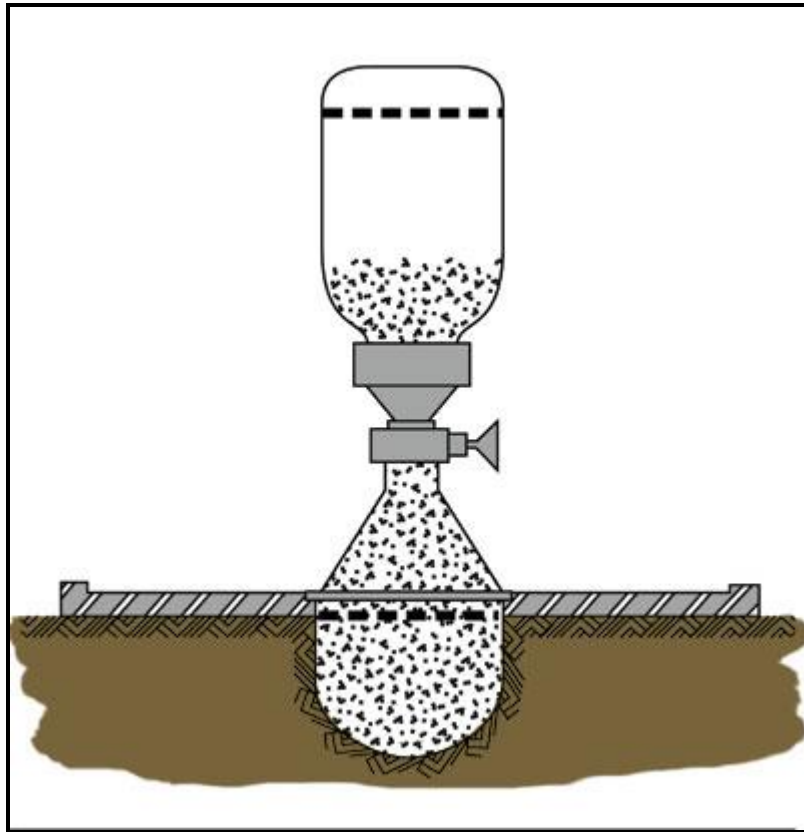

**Figure 1.1:** Sand Cone Test

## 1.2 Problem Statement

In the west of Peninsular of Malaysia, Cyberjaya is a popular area with a soil profile covered with large peat land rather than other places such as Northwest Selangor and Perak Tengah. The area of this case study is in Cyberjaya located at Flagship Zone Development under Setia Eco Glade Sdn. Bhd. In this area, the ground improvement method was introduced using Prefabricated Vertical Drain (PVD).

After completion of the 8 months surcharge period, the contractor will be removing the surcharge until the proposed level as instructed by the Superintendent

Officer (SO). Before handing over to the client, the requirement from the Superintendent Officer (SO) is to carry out the final Field Density Test to ensure the soil layer is adequate with the requirement at least 90% compaction. The Superintendent Officer (SO) instruct the Field Density Test (FDT) to be performed in a trial pit which different depths, that is, 500mm for each layer from the ground platform level to the bottom of underlying soil layer.

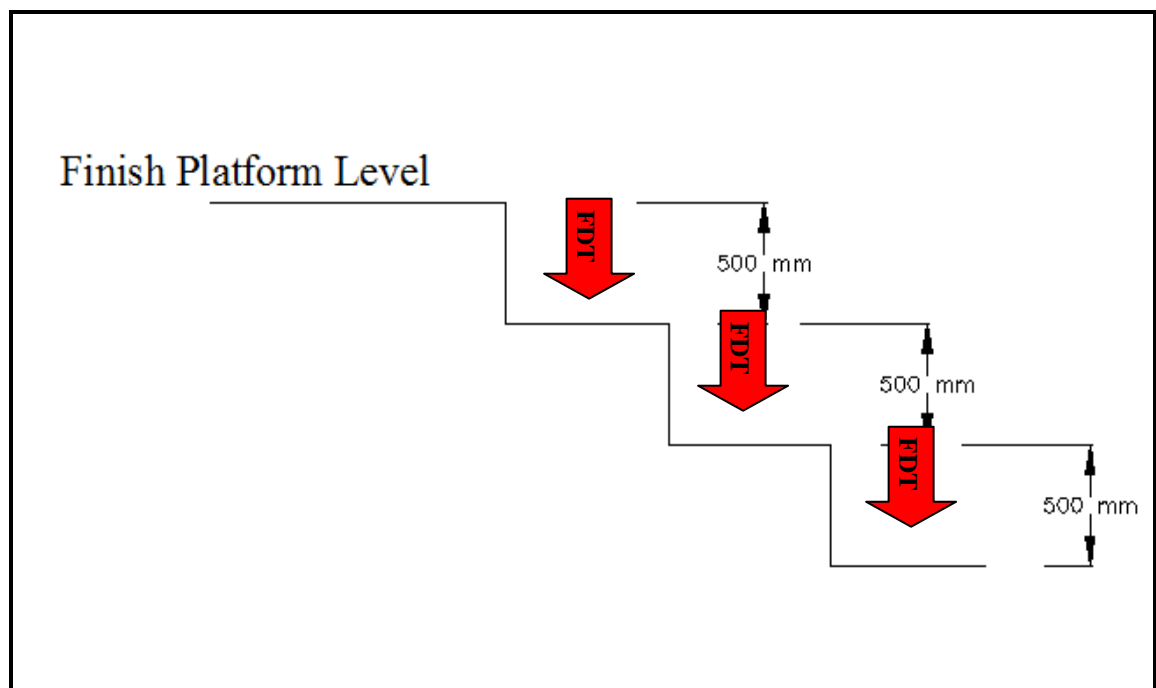

**Figure 1.2:** 500 mm thickness each step for FDT

During the excavation of the pit, the soil condition showed higher moisture content. This could be the effect of ground water suction during the surcharge period and the water rise up from sand blanket layer to the soil upper layer. However, after the test had been carried out, the result showed the compaction is less than 90% and differ from the same testing carry during filling of the ground previously.

From the result clearly showed the moisture content is higher and up till 30% of moisture content from the sample. From the result, the Superintendent Officer (SO) concluded the soil layer underneath is not compact adequately and hence requested to redo the field compaction because the requirement is at least 90% compaction. Based on the standard method of testing, the FDT should only be carry out during filling stage in which test at every 300mm thick of compacted soil layer.

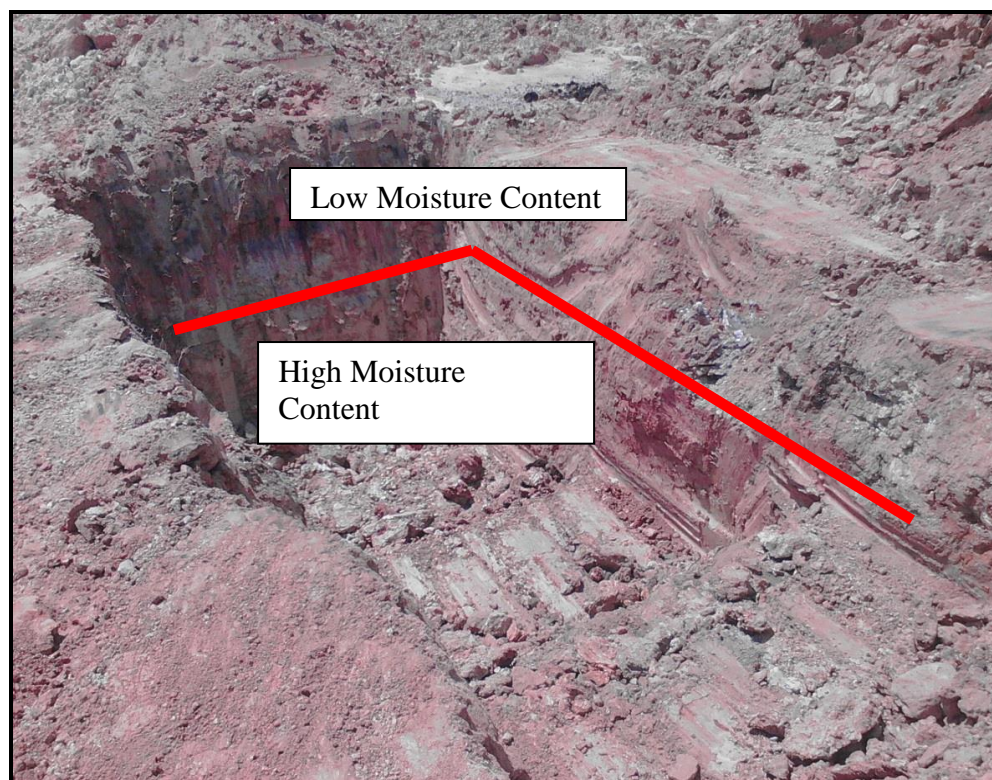

**Figure 1.3:** The pit showed the line of moisture content is high

However, the modification of FDT method to check the degree of compaction for underlying subsurface layers is not suitable in this case. This research aims to resolve some of the misconception of the testing by demonstrating

scientifically the reasons for the optimum moisture content to change and hence affecting the degree of compaction.

### 1.3 Objectives

The objectives of this study are:

- 1) To collect data from the soil test and soil investigation report.
- 2) To analyze the compaction and consolidation percentage of tested area.
- 3) To determine the strength characteristic of the soil layer within embankment.

### 1.4 Scope of Work

The study focuses on determining the compaction values at the cutting ground through the same method used in the trial pit at the embankment by Field Density Test (FDT) *Sand Replacement*. There are various limitations on the carried out for this study. They include the following:

- a. Conducting nine samples Field Density Test (FDT) with different levels at the cutting ground area located at Cyberjaya Flagship Zone development.
- b. Laboratory test were conducted to determine the Maximum Dry Density (MDD) and Optimum Moisture Content (OMC) through Modified Proctor Test.
- c. The results evaluation of compaction test conducted in accordance to *BS 1377*.

## REFERENCES

1. Attom M. (2012). *The Effect of Compaction and Initial Water Content On Soil Erosion*. Paris: Civil Engineering Department, American University Of Sharjah. ICSE6 Paris.
2. Bailey. (2008). *Cone Penetration Test (CPT)*. Savannah District: U.S. Army Corps of Engineers.
3. Bergado et. al. (2000). Recent Developments Of Ground Improvement with Pud On Soft Bangkok Clay. *Proc. Intl. Seminar On Geotechnics In Kochi 2000*. Kochi, Japan.
4. CFSD. (2003). *Density Testing and Inspection Manual*. Michigan: Construction Field Services Division, Michingan Department of Transportation.
5. David. (2006). *Subsurface Exploration Using the Standard Penetration Test and the Cone Penetrometer Test*. Rolla: Department of Geological Sciences & Engineering. The Geological Society of America.
6. Directorate, G. E. (2005). *Study Report on Compaction Equipments and Construction Machinery*. India: Research Designs & Standards Organization.
7. Garrad, B. J. (2005). *Comparison of Moisture Density Relationship Test In Civil Engineering Materials*. University Of Southern Queensland.
8. Wood M.J et. al. (2004). A Comparison of Three Methods for Measuring The Densityof A Forest Soil In New Zealand. Vol. 15, University of Canterbury, New Zealand.
9. Manoj. (1999). *Investigation Of Shrink and Swell Factors for Soils Used in FDOT Construction*. Florida: Department of Civil & Environmental Engineering. University of Central Florida.
10. Robertson. (2009). *Interpretation of Cone Penetration Tests- A Unified Approach*. Canada: NRC Research Press.
11. Selim et. al. (2008). Investigation of Parameters of Compaction Testing. *Turkish J. Eng. Env. Sci.*

12. Soil Engineering Sectional Committee. (2007). *Methods of Test for Soils, Part XXIX Determination of Dry Density of Soil In-Place By The Core-Cutter Method. 1st Revision, Bureau Of Indian Standard.*
13. Soil Engineering Sectional Committee. (2005). *Methods of Test for Soils, Part XXVIII Determination of Dry Density of Soil In-Place By The Sand Replacement Method. 1st Revision, Bureau of Indian Standards.*
14. Stapelfeldt, T. (2010). *Preloading and Vertical Drains. Helsinki University Of Technology.*