

ORIGINAL ARTICLE

DESIGN AUTOMOTIVE DRIVER SEAT ERGONOMICALLY FOR MALAYSIAN ANTHROPOMETRY MEASUREMENT

Mugilan Muralitharan¹, Syed Ahmad Helmi^{1,2}, Kamarulafizam bin Ismail¹ and Azanizawati Ma'aram¹¹ Faculty of Mechanical Engineering, Universiti Teknologi Malaysia, 81310, UTM Skudai, Johor Bahru, Johor, Malaysia² Center for Engineering Education, Universiti Teknologi Malaysia, 81310, UTM Skudai, Johor Bahru, Johor, Malaysia

ABSTRACT

Aesthetic value of the automotive car seat has been one of the selling points of each car besides providing functions such as being safe, supportive as well provides comfort to the occupants. Other criteria considered besides the aesthetic element are cushion foam and self-adjustment factor. Ergonomics is not a new issue because most of the existing seat design today have already practiced it. Existing car seat manufacturers have considered anthropometry data. The average upon 95th percentile of human measurement had been deliberated. However, issues such as time spent driving and seat design issue have arisen upon the search of comfort and rising of musculoskeletal disease such as back pain. As a solution, this study would propose an automotive car seat design of ergonomic evolution, which would create comfort by manipulating the seat cushion foams. The proposed seat cushion foam would be use to replace the existing polymers with beanbag foam. This is inspire by the nature of beanbag, fitting up and providing comfort to the occupants of various body sizes and shapes. Malaysian anthropometry measurements are required for design of car seat, which later compared with the existing seats of commercial vehicle. The literature review showed the pressure mapping technique of respondent seating on the existing car seat. The most sensitive compartments where discomfort are experienced studied and placed with sachets filed with beanbag beads. This experiment conducted many times over a few respondents by using the pressure mat to find out, if there are any changes in terms of comfort. This design of new car seat with a manipulation cushion foam replaced with beanbag foam could be a niche to eliminate discomfort to all range body sizes and shapes.

Keywords: Car seat; anthropometry; seat cushion foam; beanbag foam

INTRODUCTION

Automotive industry is a very important to the whole world for travelling and transporting goods by road, which has been increasing day by day¹. Driver seat is very complicated, and the main part of automotive car seat are frame, padding, seat pan, head restraints system, reclining mechanism with lever trim (seat cover), and suspension system, as well seat belt, height adjustment, fore and aft adjustment which could be best illustrated in Figure 1².

The best that a seat could do is to cause no discomfort. Concern of comfortable has always been a big issue especially for those who involve mode of travelling as their job. Discomfort in the definition of traveling can be best explained as sitting in one posture for a prolonged duration³. Driving do require much patience as well energy to stay alert compared while been driven. In this case best car seat has always been an option to provide comfort and ergonomically fit the driver. Automotive car seat is products that are developed with four primary functions; aesthetically pleasing, safe, supportive and be comfortable¹.



Figure 1 - Cut Section of Driver Seat Components and Systems²

Today, innovation in automotive industry involving driver comfort has developed from being considered a luxury to become a requirement³. The factors considered upon the overall design of the seat are such as stiffness, pressure distribution and shape as well dynamic factors caused by instantaneous environment (vibration) which the seat experience³. Pressure sensitivity of the skin and underlying tissue plays a role in the way that less discomfort is experienced. The element that we would like to consider of the seat width, backrest height and seat pan length would be the anthropometry as current existing seat design would mostly consider a range of measurement rather than a design, which would accommodate anyone.

Sitting in one posture for a prolonged duration will result in increased discomfort regardless of task and vibration exposure³. Feelings of discomfort are commonly associated with pain, tiredness, soreness and numbness¹. Despite adjusting the seat in search of comfort, factors such as time spent driving and seat design issues are risk factors for low back injury⁴ as many comes in different shapes and sizes or could be defined as a set of anthropometries.

Anthropometry is the science that measures the range of body sizes in a population⁵. When designing product, it is important to remember size range using law of growth to fulfil requirements of ergonomics and human centred design, whereby scalability in ergonomics and human centred design is understood as fitting an interface or task to human of different size also physical strength⁶. The general concept of field study intended to compare an experimental group consisting of short stature drivers and a control group of drivers of average body height⁷ as could be illustrated by Figure 2.

Ergonomics is a science focused on the study of human fit, together decreased fatigue and discomfort through product design⁵. The highest consideration of ergonomics/human factor (E/HF) should always be there, however some of

the designers do not think of it becoming a design discipline⁸. Besides achieving comfortable and productive satisfaction, ergonomics aims to provide working conditions which are well above minimum required to ensure health and safety of the occupant as well minimizing musculoskeletal complaints⁹.

Ergonomics related parameters are such as: comfort related parameters which are pressure distribution over seat, thermal comfort, vibration and geometric parameters. Second, would be safety related parameters which are accidental safety. Lastly, would be health related parameters which includes spinal stability and vibration attenuation. Uniform pressure distribution along human body on the driver seat, thermal upon heat distribution over the seat and lastly vibration caused by uneven road surface are important ergonomic factors to be considered for the car seat design.

Existing car seats do consider seat dimension and anthropometry measurement as could be seen in Table 1 and Figure 3. However existing ones could still not provide comfort as well solution for back aches despite detailed consideration over the seat design. There are many other criteria that should be considered such as shock absorption materials, comfort providing materials as well duration of driving.

Table 1- Seat Dimensions and Related Anthropometric Measurements¹⁰

Seat Dimension	Anthropometry Measurement
Cushion Width	Seated Hip Breadth
Cushion Length	Buttock-to-Popliteal Length
Seat Height	Popliteal Height
Backrest Width	Chest Breadth Interscye Distance*
Backrest Height	Shoulder Height

**Distance across back between the armholes of a garment*

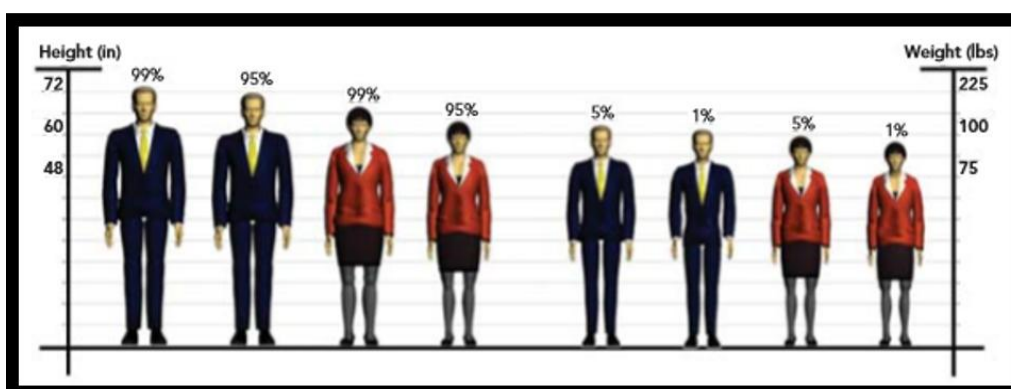

Figure 2 - Relative sizes of different human percentile⁷

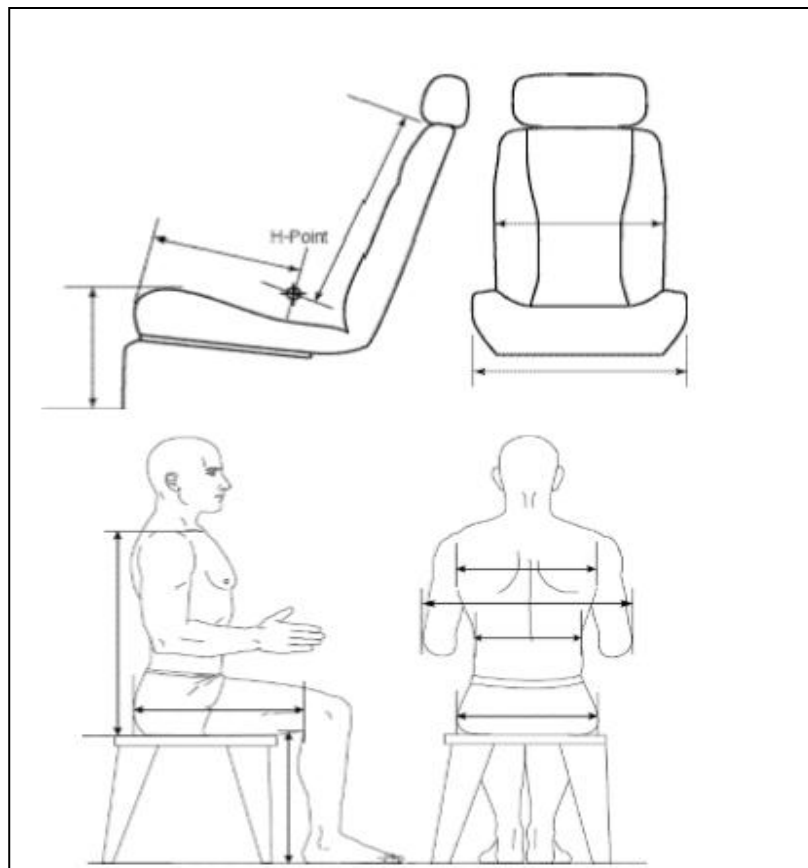

Figure 3 - Related standard anthropometric

OBJECTIVE

The main aim of this study is to design a driver seat ergonomically based on Malaysian anthropometry measurement. This study focuses at which driver seat is been manipulated by a parameter. The parameter that has been studied is the padding or namely the car seat foam which would be replaced by the existing ones to shredded bean bag beads. The specific objectives of this study are:

1. To obtain dimension of driver seat of commercial vehicle and compare with Malaysian anthropometry data and identify which design principle fits perfectly.
2. To identify the manipulated parameter on the car seat foam could provide comfort and fit human body size and shape ergonomically which is conducted by subjective measure to a few respondents.
3. To propose a new design of car seat under CAE modeling and simulation method using Dassault System software, SolidWorks.

METHODS

This study involves three main stages to be executed. The first stage is identifying. In this stage, I would like to collect dimension of commercial vehicle’s driver seat and compare with the existing anthropometry data collected whether it would fit perfectly. I would use a measuring tape in Figure 4 to obtain the dimension of the car seat as in Table 1.



Figure 4 - Measuring tape to obtain dimension of commercial vehicle car seat

The obtained dimension would later be compared with its respective anthropometry of which has been tabulated in Table 2.

Table 2: Critical measurement for cockpit accommodation¹¹

Anthropometry Dimension	
Sitting height	Height from sitting surface to the top of head
Eye height, sitting	Height from sitting surface to outer corner of eye
Interscye breadth	Horizontal distance across the back
Buttock-popliteal length	Horizontal distance from buttock to back of lower leg
Popliteal height	Vertical height from knee to the foot
Hip breadth	Maximum breadth of the lower torso
Leg length	Vertical distance from seat to floor

The second stage would be manipulating the existing parameter that has been considered to design a car seat. The pressure distribution on the driver seat which has been obtained via literature review in Figure 5 has been taken into consideration for some modification on the seat foam. The modification that would be analysed is that filling up sachets by bean bag beads and place it over the most sensitive part, which is the front part of seat pans as well top part of back rest¹².

The third stage of this study is to design a car seat which would fit Malaysian anthropometry measurement and provide comfort. Once the dimension of commercial vehicle is obtained and the best design principle been chosen over Malaysian anthropometry measurement, new design would be brainstormed. The new design would then be developed by using Dassault system, SolidWorks.

The proposed design would later be analysed in terms of ergonomics, safety as well customer satisfactory.

RESULTS

Sitting anthropometry for 376 Malaysian males and 385 females of various dimension could be seen from Table 3. This Malaysian anthropometry data would be the reference and be used to identify the basis dimension of the driver seat of each commercial vehicle commonly used in Malaysia. This could be the best in identifying the design principle of the driver seat which could be used for the brainstorm of new design as well modification in terms of car seat foam replaced with bean bag beads.

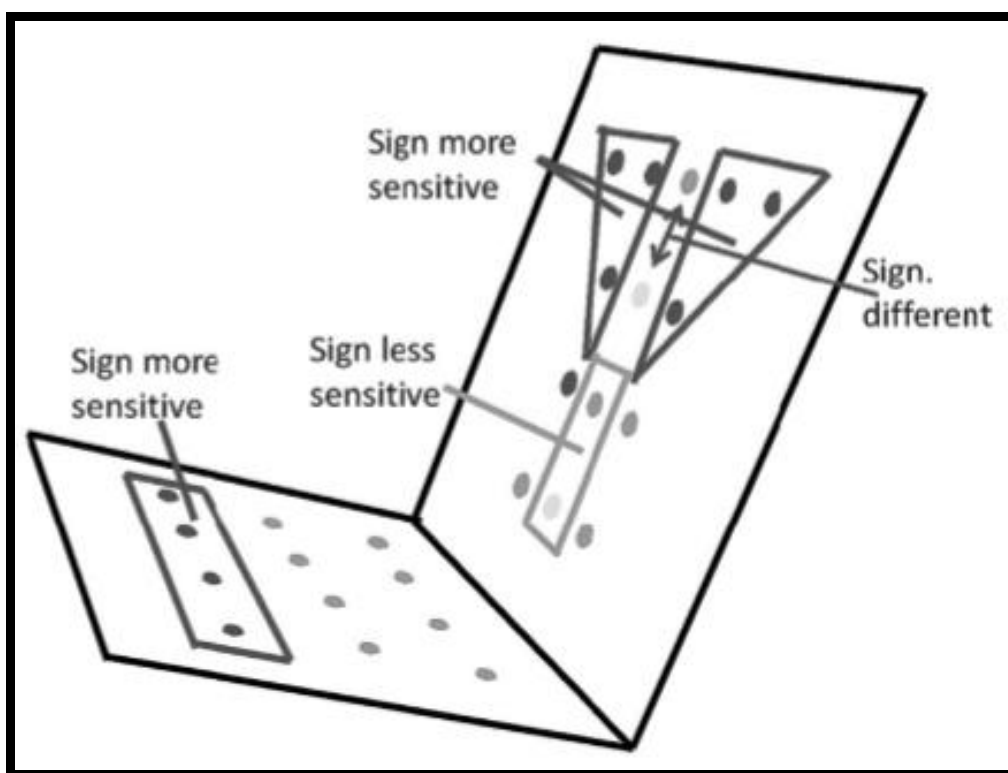

Figure 5 - Placement of pressure sensor on the seat¹²

Table 3 - Anthropometry dimension with respective measurements¹³

Gender	Male				Female			
	Mean	5 th Percentile	95 th Percentile	SD	Mean	5 th Percentile	95 th Percentile	SD
Sitting eye height	726	530	770	69	678	425	720	75
Sitting shoulder height	548	390	590	57	515	325	550	64
Interscye breadth	373	300	395	44	338	237	370	47
Buttock-popliteal length	476	380	500	44	453	360	476	45
Popliteal height	449	390	468	36	429	333	450	43
Hip breadth	366	250	400	67	379	269	420	70
Leg length	511	355	540	60	470	245	510	66

**all units are in mm. Abbreviations and Notes: SD = Standard deviation*

DISCUSSION

The dimension obtained over a few commercial vehicles which are commonly used in the roads of Malaysia is later compared with Malaysian anthropometry data required to develop a car seat as in Table 3. Before the design principle been identified by data collection over dimension measured, modification on the seat padding by replacing the existing seat foam with shredded bean bag beads could be used on identifying the pressure distribution on the driver seat over few respondents.

The pressure distribution at the human seat interface of a soft seat was measured using a flexible pressure sensing mat, under sinusoidal vibration of different magnitudes and frequencies. The contour map of static pressure distribution and time histories of the ischium pressure and the effective contact area under vibration were compared with those measured on rigid seats as in Figure 6¹⁴.

This could best explain that shredded bean bag beads could be a solution to reduce pressure distribution over the entire seat driver as bean bag beads are soft compared to existing ones which are rigid and does not follow different body sizes and shapes. This modification could somehow be a solution for the pressure to be evenly distributed through the seat in the search of comfort despite fitting each driver. This consideration could be the best method to propose a new design accordingly to fit driver by comfort.

This could best explain that shredded bean bag beads could be a solution to reduce pressure distribution over the entire seat driver as bean bag beads are soft compared to existing ones which are rigid and does not follow different body sizes and shapes. This modification could somehow be a solution for the pressure to be evenly distributed through the seat in the search of comfort despite fitting each driver. This consideration could be the best method to propose a new design accordingly to fit driver by comfort.

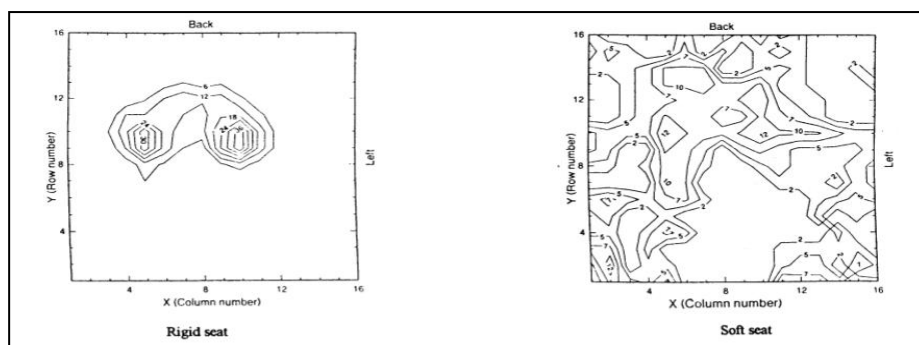

Figure 6- Static interface pressure distribution measured on the rigid and soft seat surface¹⁴

This could best explain that shredded bean bag beads could be a solution to reduce pressure distribution over the entire seat driver as bean bag beads are soft compared to existing ones which are rigid and does not follow different body sizes and shapes. This modification could somehow be a solution for the pressure to be evenly distributed through the seat in the search of comfort despite fitting each driver. This consideration could be the best method to propose a new design accordingly to fit driver by comfort.

CONCLUSION

In general, this study would be investigating on the comfort providence by manipulating one of the parameter to develop the car seat. Consequently, commercial vehicle's driver seat design principle has been the reference for a new design been proposed to fit various body shapes and sizes. This adjustability factor of the car seat according to Malaysian anthropometry measurement could fulfil most cited parameter, comfort level. The second most cited parameter, safety parameter has been considered with much concern to avoid injury to the occupant. Thus, this proposed new design could be safe and comfort for the driver besides being a solution for back ache injury due to prolonged duration of driving.

ACKNOWLEDGEMENTS

This research is partially funded by Research Grant University Vot No: Q.J13000.2624.12J23. I also would like to dedicate to NIOSH Johor, Ergonomic Department for the help on the anthropometry data been given to conduct my research. Lastly, I would like to thank Dr Zulhilmi bin Che Daud, the Head of Automotive lab for sponsoring a car seat for me to complete this research accordingly.

COMPETING INTERESTS

There is no conflict of interest.

REFERENCES

- Kolich, M. Using failure mode and effects analysis to design a comfortable automotive driver seat. *Applied Ergonomics* 2014; 45(4): 1087-1096.
- Kale, H.N. & Dhamejani, C.L, Design parameters of driver seat in an automobile. *International Journal of Research in Engineering and Technology* 2015; 4(6): 448-452.
- Sammonds, G.M., Fray, M. & Mansfield, N.J. Effect of long term driving on driver discomfort and its relationship with seat fidgets and movements (SFMs). *Applied Ergonomics* 2017; 58: 119-127.
- De Carvalho, D.E. & Callaghan, J.P., 2012. Influence of automobile seat lumbar support prominence on spine and pelvic postures: a radiological investigation. *Applied Ergonomics* 43(5): 876-882.
- Allsteel, S.O. & Allsteel, E.T. Ergonomics and design a reference guide. Muscatine (IO): Allsteel Incorporation. 2006.
- Lotz, J., Freund, T., Würtenberger, J. & Kloberdanz, H. Principles to develop size ranges of products with ergonomic requirements, using a robust design approach. *Procedia Manufacturing* 2015; 3: 6305-6312.
- Malczyk A, Müller I, Essers S, Hänsel M: Effects of Seating Position of Short Stature Drivers in Frontal Impacts. 2013, IRCOBI Conference Proceedings.
- Wilson, J.R. Fundamentals of systems ergonomics/human factors. *Applied Ergonomics* 2014; 45(1): 5-13.
- National Occupational Health and Safety Commission. Ergonomic Principles and Checklists for the Selection of Office Furniture and Equipment, 1991; November: 1-45.
- Reed, M. P. Survey of Auto Seat Design Recommendations for Improved Comfort, 2000; April.
- Blanchonette P. Vehicle Anthropometric Specification. Defence Science and Technology Organisation Victoria (Australia) Air Operations Div. 2013; April.
- Vink, P & Lips, D. Sensitivity of the human back and buttocks: The missing link in comfort seat design, *Appl. Ergon.*, 2017; 58: 287-292.
- Deros, B.M., Mohd Yusuff, R., Mohamad, D., Yusoff, A.R. Anthropometric research in Malaysia. Selangor: National Institute of Occupational Safety and Health (NIOSH), Malaysia 2013.
- Wu, X., Rakheja, S. & Boileau, D. Distribution of human seat interface pressure on a soft automotive seat under vertical vibration. *International Journal of Industrial Ergonomics* 1999; 24: 545-557.