

## TERAHERTZ TIME-DOMAIN SPECTROSCOPY OF LOCAL COW'S TISSUES

<sup>1\*</sup>SITI NORFARHA MAT RIFIN, <sup>1</sup>YUSOF MUNAJAT, <sup>1</sup>NABILAH KASIM, <sup>1</sup>MUHAMMAD HAMDI, <sup>2</sup>AHMAD ZULHILMI ARSHAD, <sup>3</sup>MOHD ZAMANI ZULKIFLI, <sup>3</sup>CHONG WU YI, <sup>3</sup>HARITH AHMAD & <sup>4</sup>NOR FARHAH RAZAK

<sup>1</sup>Department of Physics, Faculty of Science, Universiti Teknologi Malaysia, 81310 Skudai, Johor, Malaysia

<sup>2</sup>Faculty of Biosciences and Medical Engineering, Universiti Teknologi Malaysia, 81310 Skudai, Johor, Malaysia

<sup>3</sup>Photonics Research Center, Department of Physics, University of Malaya, 50603 Kuala Lumpur, Malaysia

<sup>4</sup>Pusat PERMATApintar Negara, Universiti Kebangsaan Malaysia, 43600 Bangi Selangor

<sup>1</sup>farhamatrifin@gmail.com, <sup>2</sup>yusofm@utm.my, <sup>3</sup>k.nabilah@utm.my, <sup>4</sup>hamdi13muh@gmail.com, <sup>5</sup>a.zulhilmi@gmail.com, <sup>6</sup>wuyi@um.edu.my, <sup>7</sup>mohdzamani@um.edu.my, <sup>8</sup>harith@um.edu.my, <sup>9</sup>nfarhah@ukm.edu.my

**Abstract.** This study demonstrates terahertz time-domain spectroscopy characterization of animal tissues obtained from local cow at mart. Terahertz radiation is highly sensitive to the polar molecules of water, thus biological tissues with high level of hydration show strong absorption at terahertz frequencies. All tissue samples are desiccated at same temperature and time scale. The different frequency-dependent response to the terahertz radiation due to the water content are observed from the experimental data of the fat, muscle and mixed of both tissues.

*Keywords* Terahertz; spectroscopy; biological tissues

### 1.0 Introduction

Terahertz (THz) ray recently become researchers' interests as its offer variety of technique in the area of the non destructive evaluation due to the non-ionizing, non-invasive, coherent quasi-optic, and phase-sensitive properties of the THz ray features [1]. THz ray is an electromagnetic radiation that lies between infrared and microwave regions with spectrum frequency range from 0.1 to 10 THz, it has wide perspective for spectroscopic [2], sensing [3] and imaging application [4, 5] especially in medical and biomedical fields [6]. THz time domain spectroscopy (THz-TDS) has shown potential in characterizing the spectral properties of materials since rotational and vibrational of many molecules particularly organic ones can be observed as absorption peak in the THz spectra. Molecules involved can be identified by the specific location and amplitudes of these absorption peaks. In the late of 90s, much research on THz time-domain spectroscopy (THz-TDS) in biology and medical fields had been reported, which focused more on molecules and proteins for instance DNA molecules [7-9]. Then, the

studies expand on the tissue such as skin and breast for cancer diagnosis [10]. Most of the biological tissues content is water media; and this give difficulty to the THz-TDS in biomedical field as water absorption is one of the major issues as it significantly distorts the output signals profile. Thus, this work focused on THz-TDS profile towards ~75% to 85% desiccated local cow tissues while observing the distortion in the spectroscopy signals that affected by the water presence. Three samples of tissues are involved including fat tissue, muscle tissue and mix of both tissues. The data derived from THz-TDS measurement show clear absorption profile distinction of different type of tissues samples.

## Experimental setup

Figure 1 is the experimental setup of the THz-TDS. The generation and detection of the terahertz ray is employing by photoconductive antenna which act as emitters and receiver. A femtosecond laser at wavelength 800 nm with optical pulse generated from a self mode-locked Ti-Sapphire crystal is used as the laser source. The ultra-short pulses are guided to the compressing or expanding telescope formed by lenses L1 and L2. The compression or ratio of the telescope is selected in order to obtain approximately 4 mm beam diameter size. Half wave plate, HWP 1 and polarizer, P1 are used to split part of pumping power for pumping of THz emitter. The amount of power can be adjusted by changing the angle of HWP 1. Emitter pumping beam then are directed to the optical delay line based on hollow retro reflector, HLR 1 guided by mirrors, M3 and M4 to the THz emitter. Lens L3 focussed the pumping beam to the gap of the photoconductive antenna in the THz emitter. While half wave plate, HWP 2 and polarizer, P2 are used to split part of pumping power for probing of THz detector. The probe beam then are guided by the mirrors, M5 and M6 to the lens L4 and focussed to the gap of photoconductive antenna in the THz detector. The average power of pumping pulses focussed into the THz emitter and detector photoconductive antennas are ~22 mW and ~15 mW respectively. Thus, the THz-TDS system should have a useful bandwidth of 0.3 – 4.0 THz.

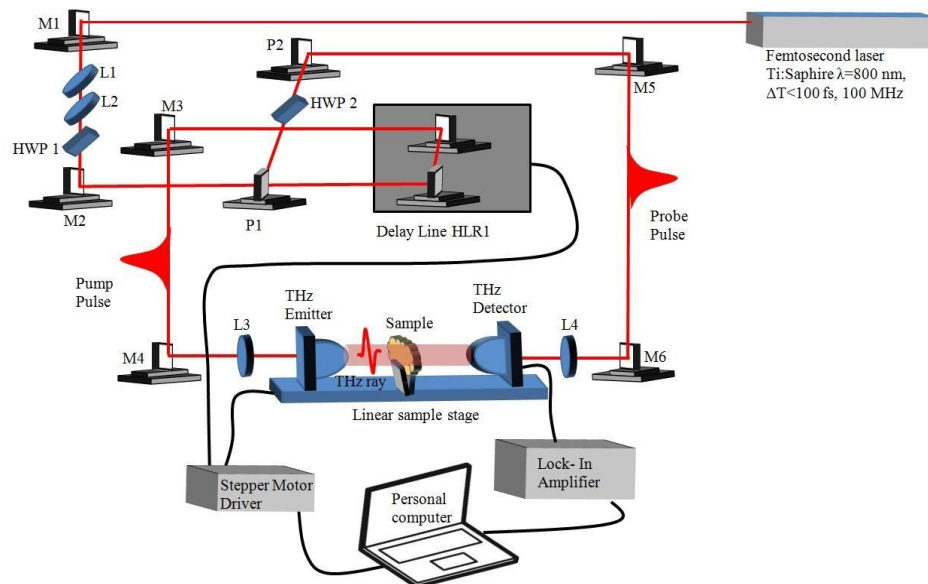

Figure 1: Setup of THz-TDS

## Sample preparation

A local cow is chose as a biological sample. The samples are cut into 3 x 3cm square shape with thickness of 1cm each and categorized into three different types of tissues which are fat, muscle, and mixed of fat-muscle. In order to reduce the water absorption when scanning with THz-TDS, the samples then are heated to 90°C for one hour. The samples are dehydrated around 75% to 85% after the heating process. Figure 2 shows the prepared samples.

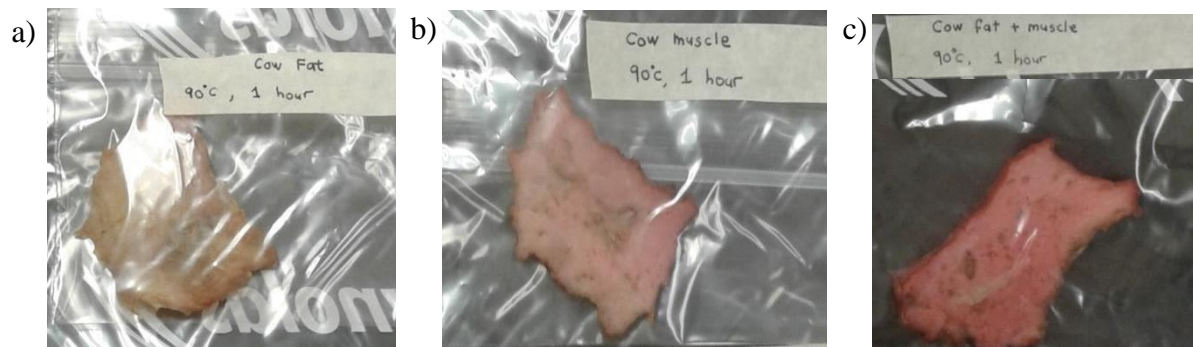

Figure 2: Prepared samples a) fat b) muscle c) both mixed fat and muscles

## Data Spectral

Data are collected by using Ekspla Terahertz Time Domain Spectroscopy (THz-TDS) with Spectra-Physics Tsunami laser system. This system is employing photoconductive method to generate and detect the terahertz pulse in transmission mode. The sample is located between THz emitter and detector and the distances in between 12 cm. This THz-TDS system can measure the spectral between 0.3 THz until 4.0 THz. Measurements of references of the lab environment are taken before the samples. All samples is detected and measured three times and their average spectrum is used as sample signal to reduce the random error.

## Data Extraction

After the raw THz data of samples were acquired, Fast Fourier Transform (FFT) was applied on both sample and reference signals to get the spectrum distribution of THz pulse in frequency domain and then Fresnel equations were used to obtain the absorption coefficient.

## Result and Discussion

The transmitted time domain terahertz pulses and corresponding frequency spectra of the air reference in Figure 3 show the system performance at expectation waveform of THz with bandwidth of ~0.8 THz. The low THz bandwidth measurement may influenced by environment atmosphere and room temperature [11].

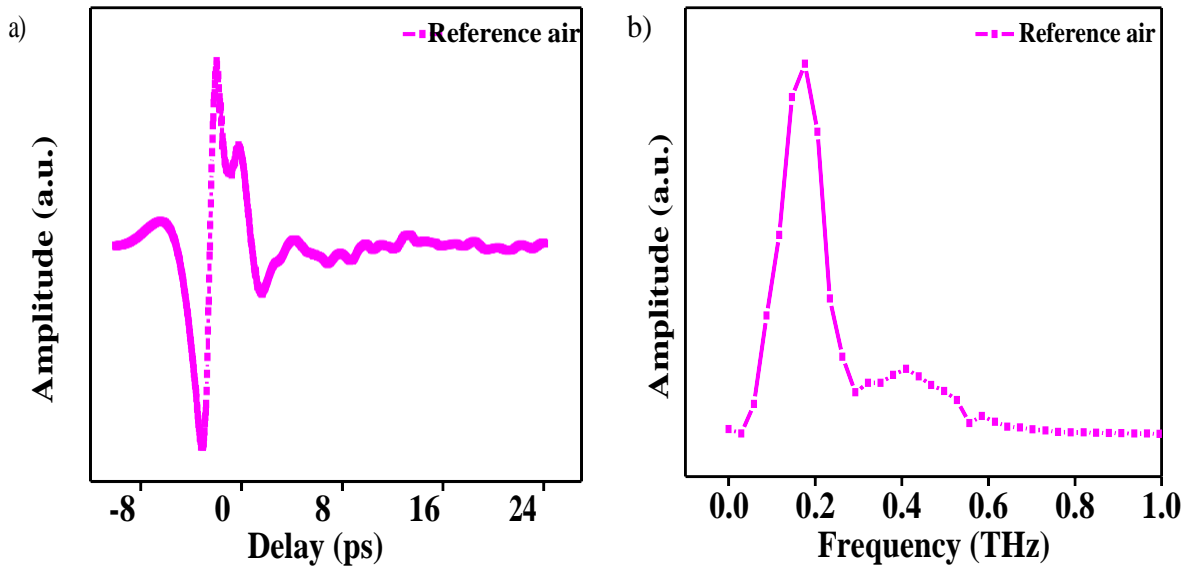

Figure 3: a) Transmitted THz pulses at reference air, b) Frequency spectra of THz pulses at reference air

The characterize of the tissue samples include fat, muscle and mixed of both tissues resulting different level of broadening, phase shift and amplitude attenuation of THz optical spectra and frequency dependent absorption. Figure 4 shows the comparison of optical spectra pulse of those three samples. The signals obtained for all samples are considerably weak compared to amplitude signal of the reference air in Figure 3(a) due to the water content even though after dehydration process is executed. However, the fat tissue owing to low level of hydration shows strong transmitted signals higher than signals from muscles tissue and mixed of both tissue. The THz signal for the mixed of both tissues on the other hand, has stronger amplitude compared to the THz signal from the muscle tissue. This also resulted from the difference of water content. THz frequency is increased with the increasing of water absorption, thus, the transmission spectra of the mixed of both tissues and muscle tissues in Figure 5 depict almost no bandwidth. Indicate that those tissues at thickness 1 cm are opaque to the THz radiation in this system. But then again for fat tissue the bandwidth is  $\sim 0.3$  THz, specify that THz radiation can be observed at thickness of 1 cm compared to other samples. The profile of the THz response in this study agreed with work in [11] as they state that same type of tissues for different animals show similar Terahertz response where in previous work, pork and rat tissues is utilized.

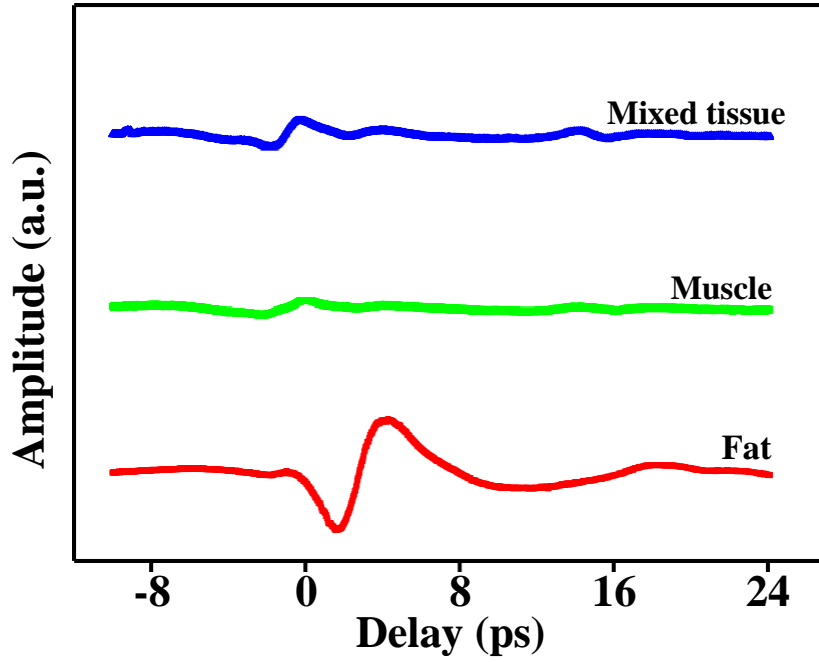

Figure 4: Transmitted THz pulses of mixed tissue, muscle and fat

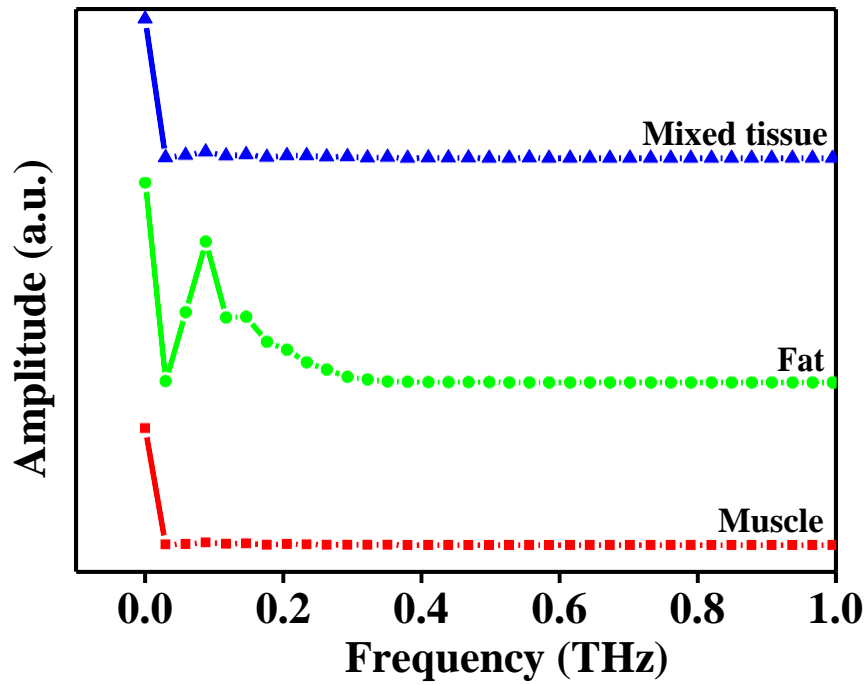

Figure 5: Frequency spectra of THz pulses of mixed tissue, muscle and fat

Figure 6 shows the absorption of the THz signal for the three samples where mixed tissue show highest absorption compared to another two samples and exhibit multiple peaks at high power absorptions. The fat and muscle tissue show low absorptions signals at THz frequency as peaks obtained has low power absorption for each sample signals.

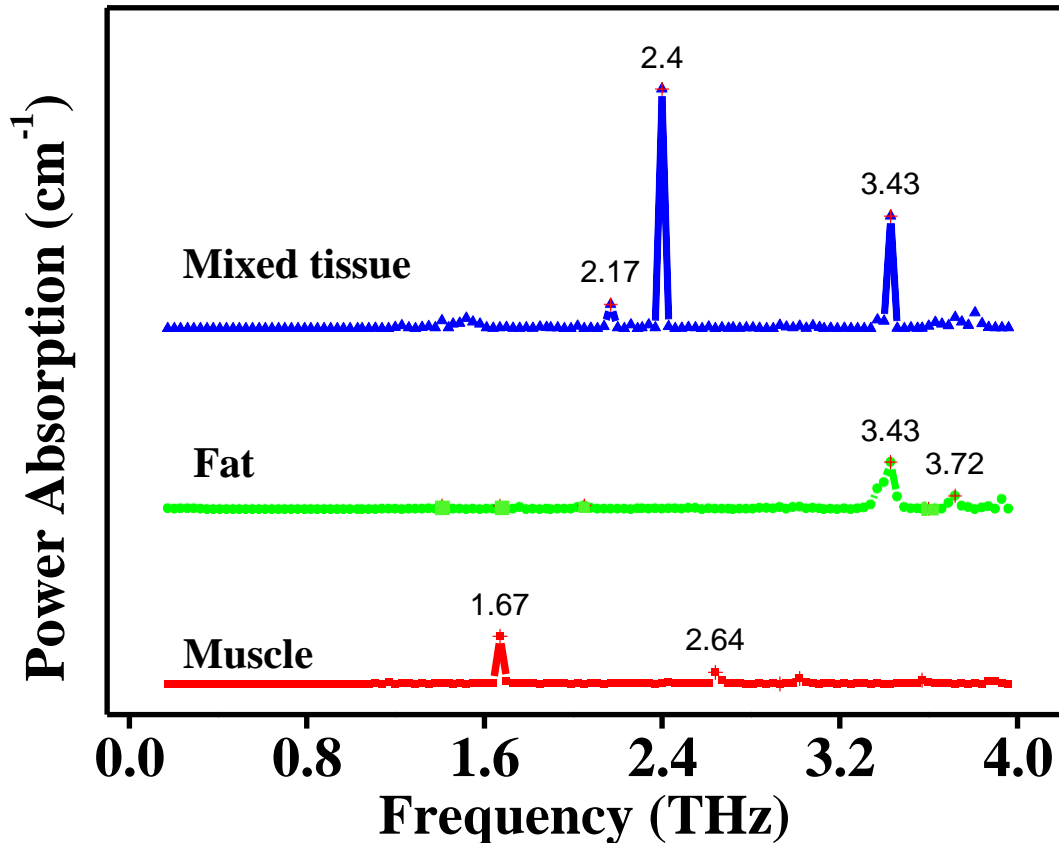

Figure 6: The absorption of the THz signal for samples tissues fat, muscle and mixed of both tissues.

#### 4.0 Conclusion

The THz-TDS transmitted time-domain pulses, the Fourier transformed spectra and the absorption of THz signals enables the differentiation between different types of animal. However same types of tissues provide similar THz response profile depends on the THz ray energy and bandwidth emitted. The obvious THz tissues signatures observed for different type of animal tissues further demonstrate the feasibility of using THz technology in the biomedical application.

## ACKNOWLEDGMENTS

Greatest appreciation to Photonic Research Centre University of Malaya, Universiti Teknologi Malaysia and Ministry of Higher Education of Malaysia (MOHE) in funding the this research work under Research Universities Grant Scheme grant no. Q.J130000.2526.06H63

## REFERENCES

- [1] Zoomega Terahertz Corporation “ The Terahertz Wave Ebook: Technical Overview”, pp 1-84, 2012.
- [2] R. M. Smith and M. A. Arnold, "Terahertz Time-Domain Spectroscopy of Solid Samples: Principles, Applications, and Challenges," *Applied Spectroscopy Reviews*, vol. 46, pp. 636-679, 2011.
- [3] D. J. Cook, B. K. Decker, G. Maislin, and M. G. Allen, "Through container THz sensing: applications for explosives screening," in *Integrated Optoelectronic Devices 2004*, 2004, pp. 55-62.
- [4] S. Wietzke, C. Jördens, N. Krumbholz, B. Baudrit, M. Bastian, and M. Koch, "Terahertz imaging: a new non-destructive technique for the quality control of plastic weld joints," *Journal of the European Optical Society-Rapid publications*, vol. 2, 2007.
- [5] S. Y. Huang, Y. X. Wang, D. K. Yeung, A. T. Ahuja, Y. T. Zhang, and E. Pickwell-Macpherson, "Tissue characterization using terahertz pulsed imaging in reflection geometry," *Phys Med Biol*, vol. 54, pp. 149-60, Jan 7 2009.
- [6] F. L. Jiang, I. Ikeda, Y. Ogawa, and Y. Endo, "Terahertz absorption spectra of fatty acids and their analogues," *Journal of oleo science*, vol. 60, pp. 339-343, 2011.
- [7] A. Markelz, A. Roitberg, and E. Heilweil, "Pulsed terahertz spectroscopy of DNA, bovine serum albumin and collagen between 0.1 and 2.0 THz," *Chemical Physics Letters*, vol. 320, pp. 42-48, 2000.
- [8] B. Fischer, M. Walther, and P. U. Jepsen, "Far-infrared vibrational modes of DNA components studied by terahertz time-domain spectroscopy," *Physics in medicine and biology*, vol. 47, p. 3807, 2002.
- [9] M. Brucherseifer, M. Nagel, P. H. Bolivar, H. Kurz, A. Bosserhoff, and R. Büttner, "Label-free probing of the binding state of DNA by time-domain terahertz sensing," *Applied Physics Letters*, vol. 77, pp. 4049-4051, 2000.
- [10] M.-A. Brun, F. Formanek, A. Yasuda, M. Sekine, N. Ando, and Y. Eishii, "Terahertz imaging applied to cancer diagnosis," *Physics in Medicine and Biology*, vol. 55, p. 4615, 2010.
- [11] M. He, A. K. Azad, S. Ye, and W. Zhang, "Far-infrared signature of animal tissues characterized by terahertz time-domain spectroscopy," *Optics Communications*, vol. 259, pp. 389-392, 2006.