

# Economic Assessment of Microalgae-Based CO<sub>2</sub> Utilization in Power Plant Sector in Malaysia

Muhammad Nurariffudin<sup>a</sup>, Haslenda Hashim<sup>\*,a</sup>, Lim Jeng Shiun<sup>a</sup>, Ho Chin Siong<sup>b</sup>

<sup>a</sup>Process System Engineering Centre (PROSPECT), Faculty of Chemical and Energy Engineering, Research Institute for Sustainable Environment (RISE), Universiti Teknologi Malaysia, Johor, Malaysia

<sup>b</sup>UTM Low Carbon Asia Research Centre, Universiti Teknologi Malaysia, Johor, Malaysia  
 haslenda@utm.my

Fossil fuel-fired power plants are the largest source of Carbon Dioxide (CO<sub>2</sub>) emissions. Microalgae-based Carbon Capture and Utilization (CCU) has becoming one of the promising technologies to reduce CO<sub>2</sub> emissions due to the ability of microalgae to absorb the CO<sub>2</sub> for photosynthesis. Integrating this technology with other CO<sub>2</sub> mitigation practices such as co-firing biomass with coal may potentially becoming a potential solution to solve the aforementioned issue towards achieving total negative emissions. In this study, the economic potential of integrated coal-fired power plant comprising of biomass co-firing with microalgae-based CCU (Bio-CCU) is investigated.

## 1. Introduction

Government of Malaysia has pledged to reduce 45 % of CO<sub>2</sub> emissions by 2030 as compared to the previous pledge which is to reduce carbon emission intensity of gross domestic product (GDP) up to 40% by 2020 (Goh, 2015). In supporting this pledge, various agencies and industries are increasing their efforts to meet the future target. In Malaysia, one of the strategies to reduce the GHG emissions contributed by power generation sector is through the utilization of renewable energy. However, the percentage of renewable energy implementation is still low in Malaysia. Hence, it is important to introduce new strategy which may efficiently mitigate the GHG emissions.

One of effective strategies is by the implementation of Carbon Capture, Utilization and Sequestration (CCUS). The term CCUS is resulted from combination of two concepts which are Carbon Capture and Storage (CCS) and Carbon Capture and Utilization (CCU). As these two terms have their own respective meaning, the main goal is one, which is to reduce CO<sub>2</sub> emissions worldwide towards achieving total negative emissions of GHG. Numerous research in CCUS area is majorly focusing on CO<sub>2</sub> injection for Enhanced Oil Recovery (EOR) and CO<sub>2</sub> sequestration in the geological sites. The major problems regarding these two technologies are high investment and operating costs of CO<sub>2</sub> transportation and compression (Hasan *et al.*, 2015). Therefore, it is important to introduce CO<sub>2</sub> utilization technologies which neglects the needs of CO<sub>2</sub> transportation and compression such as microalgae bio-fixation technology.

Microalgae-based technology provides unique approach to reduce CO<sub>2</sub> emissions due to the ability of microalgae to absorb CO<sub>2</sub> for photosynthesis (Gutiérrez-Arriaga, 2014). Microalgae also can double its own biomass in less than one day for most of species (Tredici, 2010). Substantial amount of works regarding the individual development of microalgae technologies have already been conducted. However, only few studies are conducted regarding the optimal planning network which involves the integration of coal-fired power plant with microalgae-based CCU. The integrated system consisting of biomass co-firing with microalgae-based CCU (Bio-CCU) has a potential to provide effective solutions for CO<sub>2</sub> abatement in Malaysia. Therefore, this paper first reviews applications of oil palm biomass for co-firing system, their availability in specific case study area and then discussing on the proposed Bio-CCU complex. Case study with economic analysis is also presented for possible extension into detailed studies later.

## 2. Technology reviews

The first section reviews the potential of oil palm biomass for co-firing in Malaysia whereas second section reviews the Bio-CCU technology.

### 2.1 Oil palm biomass for co-firing

Co-firing can be defined as combustion of two or more different fuels in same power generation system purposely to reduce CO<sub>2</sub> emissions resulted from combustion of fossil fuels (Rahman and Shamsudin, 2013). Co-firing coal with biomass causes less CO<sub>2</sub> emissions as biomass substitutes lower carbon content than coal. In Malaysia, oil palm became the largest contributors of biomass (77 %), followed by rice residue (9.1 %) and forestry residue (8.2 %) while the remaining 5.2 % are consists of other agricultural biomass (Griffin et al., 2014). As reported by Abdullah et al. (2015), oil palm biomass can be categorized as oil palm fronds (OPF), oil palm trunks (OPT) and fresh fruit bunch (FFB) with FFB can be divided into various type of biomass. FFB consists of crude palm oil (CPO), palm kernel (PK), palm kernel shell (PKS), mesocarb fibre (MF), empty fruit bunch (EFB) and palm oil mill effluent (POME). EFB is chosen to be co-fired with coal due to its known usage for electricity generation in the same case study area. EFB amount is acquired by multiplying annual FFB production with EFB generation rate, 0.2 t EFB/t FFB (Uemura et al., 2016).

In Perak, Maju Intan Biomass Energy Sdn Bhd is becoming one of the pioneers on the implementation of renewable energy (RE) technology in this state. With the plant capacity of 12 MW, the energy production requires about 500 t daily of EFB, equivalent to 182,500 t/y (Loh, 2015). Assuming only this company is using EFB in Perak, there is still a large amount of unutilized EFB in that state. To provide a realistic case study, assumption of 50 % EFB utilization in Perak is used. Table 1 shows the FFB and EFB scenario in Perak. Based on remaining figure which is 972,922 t/y, the availability of EFB should be sufficient enough to be utilized for co-firing system.

Table 1: Annual production of FFB and EFB in Perak state

	Amount (t/y)	Reference
FFB annual production	8,460,189	MPOB (2015)
EFB annual production	1,945,844	MPOB (2015)
Unutilized EFB	972,922	-

### 2.2 Integrated Bio-CCU complex

As the common supply chain networks proposed by previous researchers are highly related to EOR-based CCS technology, the need to proposed different network is essential in discovering the possibility of other system to mitigate CO<sub>2</sub>. The proposed network as illustrated in Figure 1 shows supply chain flow diagram which involves types of fuel, power generation section, CO<sub>2</sub> capture technologies and microalgae processing technologies. In this study, only a single selection of technology for each section in the network is included to accommodate simplified assessment. MEA absorption is chosen for CO<sub>2</sub> capture and bubble column photobioreactor (PBR) is chosen for cultivation technology. The aim of Bio-CCU is to reduce the total net emissions of CO<sub>2</sub> by substituting coal with biofuels which have lower carbon content. Microalgae processing enhances the CO<sub>2</sub> mitigation by absorbing the CO<sub>2</sub> from combustion of fuels and then producing dried microalgae biomass which also can be co-fired in the boiler.

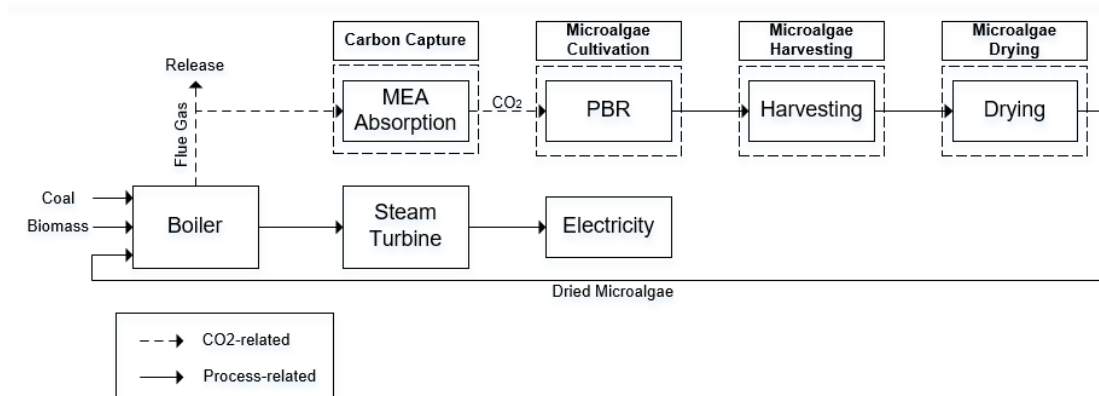

Figure 1: Integrated Bio-CCU complex

### 3. Case study: Economic potential and CO<sub>2</sub> emission reduction of an integrated system

Case study area is located in Manjung, Perak, where there is a 3100 MW coal-fired power plant known as Sultan Azlan Shah Power Station, owned by Tenaga National Berhad (TNB) (TNBF, 2015a). The case study considers the analysis of three power plant types which are pulverized coal (PC), co-fired power plant (CPP) and biomass co-firing power plant with CCU (Bio-CCU). Electricity generation and CO<sub>2</sub> emission are calculated by multiplying the amount of fuel consumed with fuel conversion factor (MWh/t fuel) and fuel emission factor (t CO<sub>2</sub>/t fuel) respectively. Table 2 provides information regarding both conversion factors. In this study, one unit of TNB Janamanjung power plant with a capacity of 1000 MW is chosen for case study to illustrate the materials flow through single unit boiler with steam turbine. The capacity factor of coal-fired power plant is 68.5 % (EIA, 2016). This study considers co-firing rate of 20 % for both CPP and Bio-CCU cases. For Bio-CCU, 10 % of EFB co-firing rate and 10 % of microalgae co-firing rate are considered. For microalgae processing, the operating conditions are 4.02 g CO<sub>2</sub>/L.d of CO<sub>2</sub> fixation rate, 2.19 g algae/L.d of algae yield, 28 MJ.m<sup>-2</sup>.d<sup>-1</sup> of radiation, 4 % of photosynthetic efficiency and 40 m<sup>-1</sup> of surface to volume ratio (S-V) (Rezvani et al., 2016).

Table 2: Fuel conversion and emission factors

Fuel type	Fuel conversion factor (MWh/t fuel)	Reference	Fuel emission factor (MWh/t fuel)	Reference
Coal	8.140	Kadam (2002)	2.560	EPA (2014)
EFB	5.370	Fan et al. (2011)	0.510	Klaarenbeeksingle (2009)
Microalgae	3.950	Ma and Hemmers (2011)	0.492	Ma and Hemmers (2011)

Table 3: Power plant information

Plant information	PC	CPP	Bio-CCU
Coal (t/y)	737,174	589,740	589,740
EFB (t/y)	-	223,486	111,743
Dried microalgae (t/y)	-	-	151,914
Capacity (MW)	1,000	1,000	1,000
Annual generation (MWh/y)	6,000,600	6,000,600	6,000,600

Table 4: Microalgae bio-fixation operating conditions

Plant information	Value	Unit	References
Fixation rate	4.02	g CO <sub>2</sub> /L.d	Rezvani et al., 2016
Algae yield	2.19	g algae/L.d	Rezvani et al., 2016
Culture volume	1.90x10 <sup>+8</sup>	L	-
Area	3.80	ha	-

Table 5: Economic parameters

Parameters	Type	Value	Unit	Reference
Electricity	Selling price	93.75	USD/MWh	TNB (2016)
Coal	Raw material price	53.00	USD/t	Sinadia (2016)
EFB	Raw material price	15.80	USD/t	Harsono et al. (2016)
Co-firing retrofit (20%)	Capital cost	1.37	USD/MWh	Griffin et al. (2014)
Power plant	Operating cost	4.32	USD/MWh	EIA (2013)
Carbon capture	Capital cost	2.80	USD/MWh	Lee et al. (2008)
	Operating cost	0.11	USD/MWh	Lee et al. (2008)
Microalgae cultivation	Capital cost	6400.00	USD/ha	Lundquist et al. (2010)
	Operating cost	115.60	USD/tonne	Lundquist et al. (2010)
Microalgae harvesting	Capital cost	24.90	USD/tonne	Lundquist et al. (2010)
	Operating cost	31.20	USD/tonne	Lundquist et al. (2010)
Microalgae drying	Capital cost	112.30	USD/tonne	Lundquist et al. (2010)
	Operating cost	134.20	USD/tonne	Lundquist et al. (2010)

Table 6: Economic assessment and percentage of CO<sub>2</sub> reduction emission

	PC	CPP	Bio-CCU
<b>Raw material costs</b>			
Coal (USD/y)	3.91x10 <sup>+7</sup>	3.13x10 <sup>+7</sup>	3.13x10 <sup>+7</sup>
EFB (USD/y)	-	3.53x10 <sup>+6</sup>	1.77x10 <sup>+6</sup>
Total (USD/y)	3.91x10 <sup>+7</sup>	3.48x10 <sup>+7</sup>	3.30x10 <sup>+7</sup>
<b>Capital costs</b>			
Co-firing retrofit (20%) (USD/y)	-	8.22x10 <sup>+6</sup>	8.22x10 <sup>+6</sup>
Carbon capture (USD/y)	-	-	1.68x10 <sup>+7</sup>
Microalgae processing (USD/y)	-	-	2.08x10 <sup>+7</sup>
Total (USD/y)	-	8.22x10 <sup>+6</sup>	4.59x10 <sup>+7</sup>
<b>Operating costs</b>			
Power plant (USD/y)	2.59x10 <sup>+7</sup>	2.59x10 <sup>+7</sup>	2.59x10 <sup>+7</sup>
Carbon capture (USD/y)	-	-	6.72x10 <sup>+5</sup>
Microalgae processing (USD/y)	-	-	4.27x10 <sup>+7</sup>
Total (USD/y)	2.59x10 <sup>+7</sup>	2.59x10 <sup>+7</sup>	6.93x10 <sup>+7</sup>
<b>Revenue</b>			
Electricity (USD/y)	5.63x10 <sup>+8</sup>	5.63x10 <sup>+8</sup>	5.63x10 <sup>+8</sup>
Total (USD/y)	5.63x10 <sup>+8</sup>	5.63x10 <sup>+8</sup>	5.63x10 <sup>+8</sup>
Profit (USD/y)	497,574,754.30	493,637,724.11	414,394,683.53
Profit penalty (%)	0 (Baseline)	-0.79	-16.72
CO <sub>2</sub> emitted (t CO <sub>2</sub> /y)	1,887,167.58	1,623,711.14	1,362,608.16
CO <sub>2</sub> fixated (%)	0 (Baseline)	13.96	27.80

The three scenarios are analysed by examining the economics and CO<sub>2</sub> emission reductions. The profit is determined by subtracting the revenue generated from electricity generation with capital and operating costs involves in each case. The profit penalty and CO<sub>2</sub> fixation rate is calculated as compare to baseline value. The base case (PC) scenario shows that without installing co-firing and CCU systems, the profit of power plant is estimated to be at USD 497,574,754.30/y. By installing co-firing system (CPP), it can be seen that profit is slightly reduced by 0.79 % at USD 3.9 million/y although annual cost of fuel is decrease. This is due to the fact that retrofitting a co-firing system in existing power plant involves minor modification on the boiler or furnace combustion system, resulting in the small addition to the investment cost. Trade-off between cost reduction and cost addition are not sufficient enough for CPP to achieve the baseline profit. This minimal decline of profit can be recovered through government incentives. Although there is no existing incentive regarding co-firing technology in Malaysia, it can be suggested that this technology should be considered for an incentive under renewable energy scheme due to the utilization of biomass as biofuel. CPP displays a great environmental performance with CO<sub>2</sub> minimization at 13.96 % as compare to the baseline emissions. This shows that implementation of biomass co-firing alone can offers a promising route for GHG mitigation. If no comparison of profit is conducted between CPP and PC, CPP still generates a high profit which is USD 493,637,724.11/y. For Bio-CCU scenario, 16.72 % of profit penalty is encountered where USD 83 million is loss annually but still, if no comparison of profit is conducted, Bio-CCU generates USD 414,394,683.53/y. The reason for this critical profit loss is due to high technological costs. As reported by Rizwan *et al.* (2015), microalgae processing facilities have high operating and investment costs due to lack amount of facilities constructed worldwide. On the other hand, this is also due to the limitations which affect the capabilities of this technology to reduce more CO<sub>2</sub> emissions. The limitation is that, the area of case study is not large enough to support a major scale implementation of microalgae PBR technology. This caused insufficient amount of PBR which can be installed to generate microalgae biomass to be co-fired. Process integration to minimize the operating cost of power plant is not conducted in this study. The integration of electricity, heat and water within the power plant will provide an optimal utilities configuration to achieve a minimum operating cost. Other than that, microalgae produced should be considered for utilization to produce more valuable bio-products such as lipid, protein, pigments and fatty acids and improve the competitiveness. Since this type of power plant also has a great performance in reducing CO<sub>2</sub> emissions, again, after solving all the limitations stated above, government incentives can really support the implementation of this promising sustainable technology. The applicability of Bio-CCU for implementation in Malaysia can be investigated for the other three states which have coal-fired power plant.

The power plants are Jimah Power Station in Negeri Sembilan, Sultan Salahuddin Abdul Aziz Shah Power Station in Selangor and Tanjung Bin Power Station in Johor (TNBF, 2015b).

#### 4. Conclusion

In this study, the economic potential of integrated coal-fired power plant which comprises of biomass co-firing technology, together with microalgae-based CCU technology is investigated. It can be concluded that installing co-firing system and CCU technology into existing power plant contributes to great performances in reducing environmental impacts but causing penalty to the profits. The case study tested the abilities of three types of power plant, PP, CPP and Bio-CCU in the reduction of CO<sub>2</sub> emissions. It can be shown that installing co-firing system (CPP) caused about 13.96% of CO<sub>2</sub> emission reduction but causing a slight decrease of the annual profit. Integrating CCU with co-firing (Bio-CCU) increased the CO<sub>2</sub> emission reduction at the rate of 27.80% but causing a 16.72% penalty to profit. However, if no comparison of profit is conducted as compare to baseline value for both of the systems, CPP and Bio-CCU still generate high profits. The drawback of this technology is high operating and investment costs of microalgae processing facilities. This cost competitiveness can be enhanced by searching for suitable area to build microalgae processing facilities, implementing microalgae-based CO<sub>2</sub> utilization to produce more valuable bioproducts and conducting process integration to reduce operating costs.

#### Acknowledgements

This study was supported by Ministry of Higher Education (MOHE) Malaysia Vot. No. 7301.4B145, Research Student Grant (RSG) Vot. No. 2546.14H46 and JICA JST SATREPS programme.

#### References

- Abdullah S.S.S., Shirai Y., Bahrin E.K., Hassan M.A., 2015, Fresh oil palm frond juice as a renewable, non-food, non-cellulosic and complete medium for direct bioethanol production, *Industrial Crops and Products*, 63, 357-361.
- EIA (U.S. Environmental Information Administration), 2013, Updated capital cost estimates for utility scale electricity generating plants, U.S. Department of Energy, Washington, DC.
- EIA (U.S. Environmental Information Administration), 2016, Electric power monthly <[www.eia.gov/electricity/monthly/epm\\_table\\_grapher.cfm?t=epmt\\_6\\_07\\_a](http://www.eia.gov/electricity/monthly/epm_table_grapher.cfm?t=epmt_6_07_a)> assessed 09.11.2016
- EPA (U.S. Environmental Protection Agency), 2014, Emission factors for greenhouse gas inventories, U.S. EPA, Washington, DC.
- Fan S.P., Zakaria S., Chia C.H., Jamaluddin F., Nabihah S., Liew T.K., Pua, F.L., 2011, Comparative studies of products obtained from solvolysis liquefaction of oil palm empty fruit bunch fibres using different solvents, *Bioresource Technology* 102, 3521-3526.
- Goh M., 2015, Malaysia pledges to cut CO<sub>2</sub> emissions intensity by 45% by 2030 <[www.channelnewsasia.com/news/asiapacific/malaysia-pledges-to-cut/2300924.html](http://www.channelnewsasia.com/news/asiapacific/malaysia-pledges-to-cut/2300924.html)> assessed 12.09.2016.
- Griffin W.M., Michalek J., Matthews H.S., Hassan, M.N.A., 2014, Availability of biomass residues for co-firing in peninsular Malaysia: Implications for cost and GHG emissions in the electricity sector, *Energies* 7, 804-823.
- Gutiérrez-Arriaga C.G., Serna-González M., Ponce-Ortega J.M., El-Halwagi M.M., 2014, Sustainable integration of algal biodiesel production with steam electric power plants for greenhouse gas mitigation, *ACS Sustainable Chemistry and Engineering* 2, 1388-1403.
- Harsono S.S., Grundman P., Lau L.H., Hansen A., Salleh M.A.M., Meyer-Aurich A., 2013, Energy balances, greenhouse gas emissions and economics of biochar production from palm oil empty fruit bunches, *Resources, Conservation and Recycling* 77, 108-115.
- Hasan M.M.F., First E.L., Boukouvala F., Floudas C.A., 2015, A multi-scale framework for CO<sub>2</sub> Capture, Utilization, and Sequestration: CCUS and CCU, *Computers and Chemical Engineering* 2, 2-21.
- Kadam K.L., 2002, Environmental implications of power generation via coal-microalgae cofiring. *Energy* 27 (10), 905-922.
- Klaarenbeeksingel F.W., 2009, Greenhouse gas emissions from palm oil production: Literature review and proposals from the RSPO working group on greenhouse gases <[www.rspo.org/files/project/GreenHouse.Gas.Working.Group/Report-GHG-October2009.pdf](http://www.rspo.org/files/project/GreenHouse.Gas.Working.Group/Report-GHG-October2009.pdf)> assessed 13.09.2016
- Lee S., Park J.W., Song H.J., Maken S., Filburn T., 2008, Implication of CO<sub>2</sub> capture technologies options in electricity generation in Korea, *Energy Policy* 36, 326-334.

- Loh I., 2015, Biomass, a game changer <[www.thestar.com.my/metro/community/2015/10/10/biomass-a-game-changer-malaysia-has-the-potential-to-be-a-success-in-the-industry/](http://www.thestar.com.my/metro/community/2015/10/10/biomass-a-game-changer-malaysia-has-the-potential-to-be-a-success-in-the-industry/)> assessed 12.09.2016.
- Lundquist, T.J., Woertz, I.C., Quinn, N. and Benemann, J.R., 2010, A realistic technology and engineering assessment of algae biofuel production, Energy Biosciences Institute, University of California, Berkeley, California.
- Ma, J. and Hemmers, O., 2011, Technoeconomic analysis of microalgae cofiring process for fossil fuel fired power plants, *Journal of Energy Resources Technology*, 133, 1-8.
- MPOB (Malaysia Palm Oil Board), 2015, Malaysian oil palm statistics <<http://bepi.mpob.gov.my/>> assessed 12.09.2016.
- Rahman, A.A. and Shamsudin, A.H., 2013, Cofiring biomass with coal: Opportunities for Malaysia. 4th International Conference on Energy and Environment (ICEE) 2013, 5-6 March, Putrajaya, Malaysia, 16, 012144.
- Rezvani, S., Moheimani, N.R., Bahri, P.A., 2016, Techno-economic assessment of CO<sub>2</sub> bio-fixation using microalgae in connection with three different state-of-the-art power plants, *Computers and Chemical Engineering*, 84, 290-301.
- Rizwan, M., Lee, J.H., Gani, R., 2015, Optimal design of microalgae-based biorefinery: Economics, opportunities and challenges, *Applied Energy*, 150, 69-79.
- Sinadia, H., 2016, Coal mining update Indonesia: Coal price rises in July <<http://www.indonesia-investments.com/news/todays-headlines/coal-mining-update-indonesia-coal-price-rises-in-july/item6989>> assessed 13.09.2016.
- TNB (Tenaga Nasional Berhad), 2016, TNB Handbook - Investor Relations & Management Reporting Department, TNB, Taipei, China.
- TNBF (Tenaga Nasional Berhad Fuel), 2015a, Coal <<http://www.tnbfuel.com/index.php/our-product/#coal>> assessed 13.09.2016.
- TNBF (Tenaga Nasional Berhad Fuel), 2015b, Our customers <<http://www.tnbfuel.com/index.php/our-customers#kapar-energy-ventures>> assessed 09.11.2016.
- Tredici, M.R., 2010, Photobiology of microalgae mass cultures: Understanding the tools for the next green revolution, *Biofuels*, 1, 143-162.
- Uemura, Y., Omar, W., Othman, N.A, Yusup, S., Tsutsui, T., 2016, Torrefaction of oil palm EFB in the presence of oxygen, *Fuel*, 103, 156-160.