

Modelling and control of horizontal flexible plate using particle swarm optimization

Muhamad Sukri Hadi^{1*}, Hanim Mohd Yatim², Intan Zaurah Mat Darus³

¹Faculty of Mechanical Engineering, Universiti Teknologi MARA, Shah Alam, Selangor, Malaysia

²Universiti Kuala Lumpur, Malaysian Institute of Industrial Technology, Bandar Seri Alam, Johor, Malaysia

³Faculty of Mechanical Engineering, Universiti Teknologi Malaysia, Skudai, Johor, Malaysia

*Corresponding author E-mail: msukrihadi@gmail.com

Abstract

This paper presents the modeling and active vibration control using an evolutionary swarm algorithm known as particle swarm optimization. Initially, a flexible plate experimental rig was designed and fabricated with all clamped edges as boundary conditions constrained at horizontal position. The purpose of the experimental rig development is to collect the input-output vibration data. Next, the data acquisition and instrumentation system were designed and integrated with the experimental rig. Several procedures were conducted to acquire the input-output vibration data. The collected vibration data were then utilized to develop the system model. The parametric modeling using particle swarm optimization was devised using an auto regressive model with exogenous model structure. The developed model was validated using mean square error, one step ahead prediction, correlation tests and pole-zero diagram stability. Then, the developed model was used for the development of controller using an active vibration control technique. It was found that particle swarm optimization based on the active vibration control using Ziegler-Nichols method has successfully suppressed the unwanted vibration of the horizontal flexible plate system. The developed controller achieved the highest attenuation value at the first mode of vibration which is the dominant mode in the system with 34.37 dB attenuation.

Keywords: Flexible plate; Active Vibration Control; Particle Swarm Optimization; System Identification.

1 Introduction

The vibration that occurs on the flexible plate structure applied in many engineering applications is undesirable, which may lead to the system failure. There are many problems faced by the industries, for instance the system is not able to achieve the desired performance due to the resonance or excessive vibration in the system. The flexible structure elements are including plates, beam, frames and shells. This structure has been widely used in the manufacturing applications such as automotive, aeronautical, civil, marine and mechanical fields (1).

The flexible structure is known as a thin and light structure that demonstrates an intrinsic property of vibration when subjected to the disturbances forces, which can lead to the structural failure (2). Due to this practical problem, the vibration of the flexible plate has been broadly treated by the researchers in order to maintain the performance of the flexible plate system. In recent years, one of the famous methods used to overcome the problem regarding on the vibration of the flexible plate is using active vibration control (AVC).

The fundamental of AVC was introduced by Lueg in the early 1930s for noise cancellation. Lueg proposed the superposition principle which the sound signal will be cancelled by introducing the secondary sound signal at 180 degrees out of phase (3). The cancelling source is generated at the desired location to interfere destructively with the unwanted vibration, thus resulting in vibration suppression on the flexible plate structure (4). Since then, the AVC method has been taken into consideration by many researchers in various applications (5-9)

Caruso, Galeani (10) proposed the application of AVC system for an elastic plate with the basic of control law. (Gardonio, Bianchi (11), 12, 13) developed a velocity feedback controller for a smart plate in order to reduce the sound radiation or transmission. On the other hand, Hu, Ma (14) developed a controller for flexible plate structure using AVC system by applying Linear Matrix Inequality-based (LMI-based) H_∞ . Furthermore, Tokhi and Hossain (15) presented the framework of adaptive control to suppress the vibration of a flexible beam using active control mechanism. Nevertheless, it is crucial to find an accurate model of the structure in order to control the unwanted vibration of the flexible plate very well. As stated by Tavakolpour, Mat Darus (16), if the system is modelled suitably and properly, it would bring good results in the aspect of controlling.

Recently, system identification has been selected by many researchers to model their system in order to predict the physical system behaviour under various operating conditions based on observed inputs and outputs. The system identification technique can be used to find an accurate model of the dynamic system based on the observed inputs and outputs (17). In many cases, the conventional identification technique was found to be inadequate in obtaining an accurate model structure of the system due to the algorithm being trapped at local minima (18, 19). Thus, one of the motivating alternatives to overcome this problem is to utilize an evolutionary swarm algorithm in order to build an accurate model of the dynamic system in this study.

It can be noticed from the previous researches that various evolutionary swarm algorithms were applied in optimization problems. Md Salleh, Tokhi (20) studied the applications of particle swarm optimization (PSO) identification of thin plate structure. Mean-

while, (21) proposed cuckoo search algorithm in solving a system of nonlinear differential equations. (22) developed the application of PSO-based identification approach of flexible plate structure. Abd Samad, Jamaluddin (23) investigated the effect of penalty function parameter in the objective function of genetic algorithm. Moreover, Abdel-Raouf and Abdel-Baset (24) proposed hybrid flower pollination algorithm with PSO to solve the constrained global optimization problems. Azraai, Priyandoko (25) investigated the parametric optimization of magneto-rheological fluid damper using PSO. On the other hand, Mohd Yatim (26) developed particle swarm optimization with explorer (PSOE) for the identification of flexible manipulator system.

The objective of this study is to develop a model of the horizontal flexible plate system using system identification technique via intelligent swarm algorithm known as particle swarm optimization (PSO). The system identification was developed based on observed inputs and outputs collected through the experimental study. The developed model was validated using mean squared error (MSE), one step ahead prediction, correlation tests and pole-zero diagram stability. Then, the developed model was used for the development of controller using active vibration control technique.

2 Literature Review

The purpose of conducting this experimental setup is to collect the input-output vibration data of the flexible plate experimentally. Firstly, the experimental rig used in this research is designed and fabricated. The flexible structures used in the experiment namely square, thin and flat aluminium plates with the dimensions of $0.7\text{ m} \times 0.7\text{ m} \times 0.001\text{ m}$ are considered. The flexible plate was placed in the horizontal position to allow it to vibrate vertically. Besides, the rig is designed with all clamped edges. The full specifications of the flexible plate used in this research are listed in Table 1.

A magnetic shaker and a circular shape permanent magnet were applied at the excitation point on the experimental rig in order to generate an actuation force when conducting the experiment. A circular shape permanent magnet was located at the distance of 1 cm parallel to the magnetic shaker at the excitation point. Then, the magnetic shaker was connected to the power amplifier (type 2706) and function generator (GFG-8250A) to create a sinusoidal actuation force in exciting the plate. The integration of the instrumentation used in the experiment is shown in Figure 1.

Two pieces of piezo-beam type accelerometer (Kistler-863650C) were used to sense the acceleration signal in order to represent the vibration of the structure. The accelerometers were attached at two different positions, particularly the observation and detection points as illustrated in Figure 2. The piezo-beam type accelerometers were directly connected to the data acquisition system (PCI 6259) which is mounted inside the computer on a PCI-bus connected with SCC-68 through shielded cable. A personal computer equipped with Intel® Core™ i7-4770K Processor, 4.00 GB RAM and MATLAB software was used to analyze the required signal obtained in this experiment.

Table 1: The specifications of flexible plate used in this research

Parameter	Value
Length, L	-0.7 m
Width, w	-0.7 m
Thickness, T	-20 × 20
Moment of inertia, I	-5.1924 × 10 ⁻¹¹ kgm ²
Mass density per Area, ρ	-2.17 × 10 ³ kg/m ³
Young's modulus, E	-7.11 × 10 ¹⁰ N/m ²
Poisson ratio, ν	-0.3

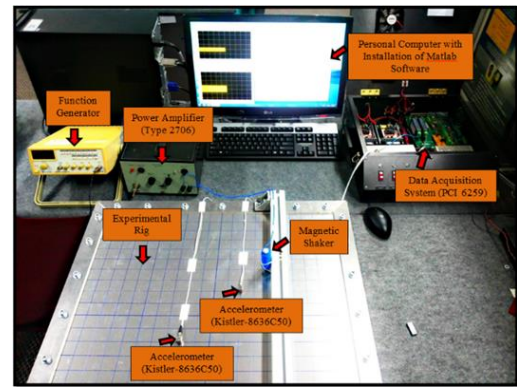

Fig. 1: The experimental setup used in this research

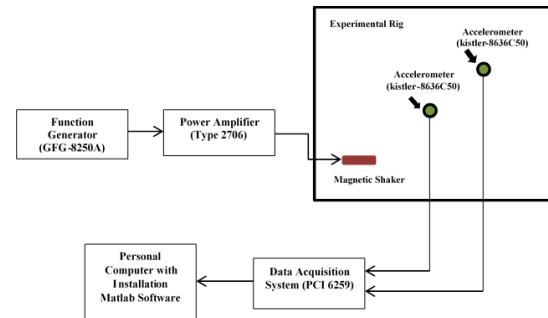

Fig. 2: The layout of experimental setup for data collection purpose

3 System Identification

In this research, system identification technique was used to model the dynamic system of the horizontal flexible plate. The intelligent swarm algorithm known as particle swarm optimization (PSO) was selected in modeling the system. Details regarding on particle swarm optimization algorithm are explained as in this paper (27). The system identification was devised using ARX model structure in the MATLAB software. There were 5000 input-output datasets that have been collected in the experiment. The datasets were divided into two parts; the first 2500 datasets were used to train the model, whereas, another 2500 datasets were used to test the performance of the developed model. The performance of developed system were validated using mean squared error (MSE), one-step ahead prediction (OSA), correlation tests and pole zero diagram stability. The structure realization was performed using heuristic method since there is no prior knowledge regarding ways to select the best model order in the horizontal flexible structure system.

For identification using PSO, the best model can be obtained by tuning on different model orders, number of particle and number of iteration. The best model order was found to be the second order, which obtained with set of parameters listed in Table 2. The best and lowest mean squared error for PSO identification are 2.3307×10^{-5} and 4.3947×10^{-6} for training and testing data, respectively. The mean square error versus number of generations has been plotted as displayed in Figure 3. On the other hand, both actual and predicted outputs of the flexible plate system in time and frequency domains are plotted in Figures 4 and 5, respectively. Based on Figures 4 and 5, it is proved that the developed model is able to imitate the measured output very well. Figure 6 shows the error occurred between actual and estimated outputs using PSO modeling.

Table 2: The set of parameters used to achieve the best performance in PSO

Parameter	Value
Number of swarm	-500
Number of generation	-400
Inertia weight, ω	-0.5
Acceleration coefficient, C1, C2	-2.0
Model order	-2
MSE for training data	-2.3307×10^{-5}
MSE for testing data	-4.3947×10^{-6}

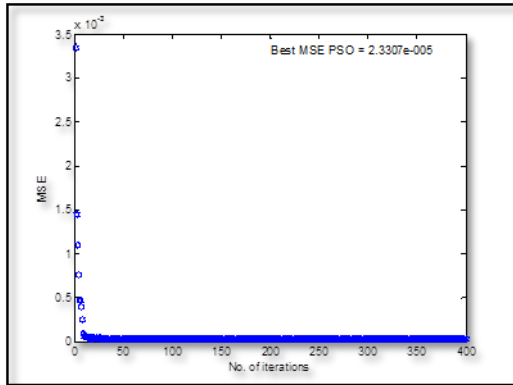
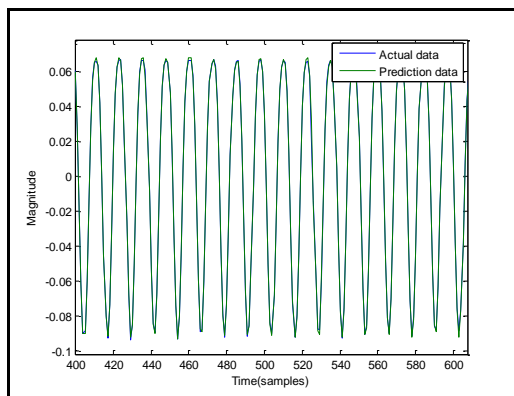
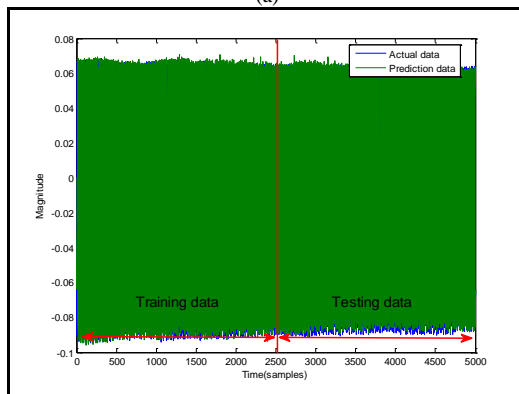

Fig. 3: The convergence of PSO modeling



(a)



(b)

Fig. 4: Actual output and estimated output of the system in time domain (a) estimated output for 5000 sample data; (b) enlarged view from the sample between 400 until 600

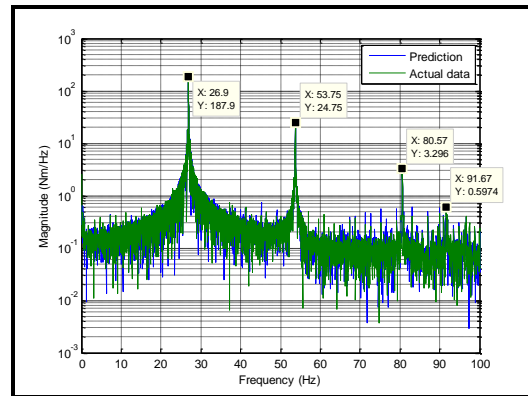

Fig. 5: Actual output and estimated output of the system in frequency domain

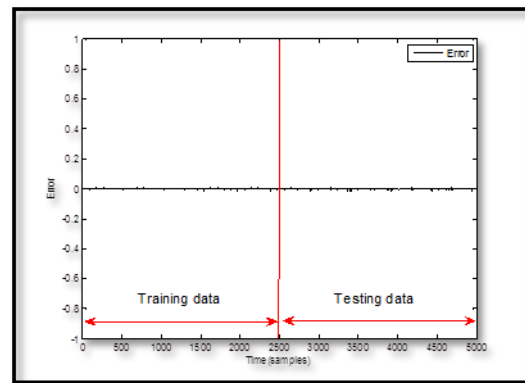

Fig. 6: Error between actual output and estimated output of the system using PSO

The pole-zero diagram and correlation tests are depicted in Figures 7 and 8, respectively. According to pole-zero diagram, it is noticed that the model was stable where all of the transfer function poles are in the unit circle. The correlation tests were carried out to determine the effectiveness of the developed system. Two correlation tests were used to validate the model, namely auto correlation and cross correlation. From these correlation tests, the model was found to be unbiased due to a 95% confidence level in the results. The transfer function obtained using PSO modeling is described in the Eq. (1). This transfer function is used later in the development of the controller for vibration suppression of horizontal flexible plate.

$$\frac{0.3483z^{-1} - 0.002183z^{-2}}{1 - 1.1414z^{-1} + 0.9931z^{-2}} \dots \quad (1)$$

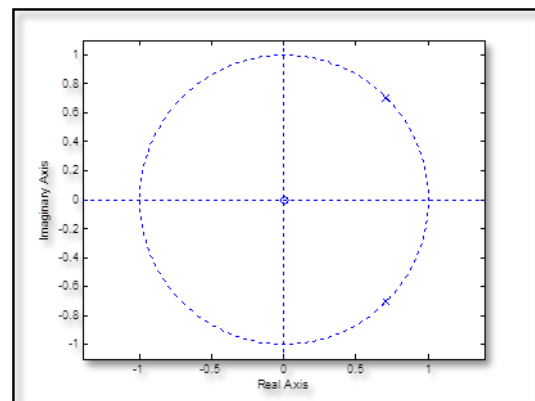

Fig. 7: Pole-zero diagram of the system using PSO

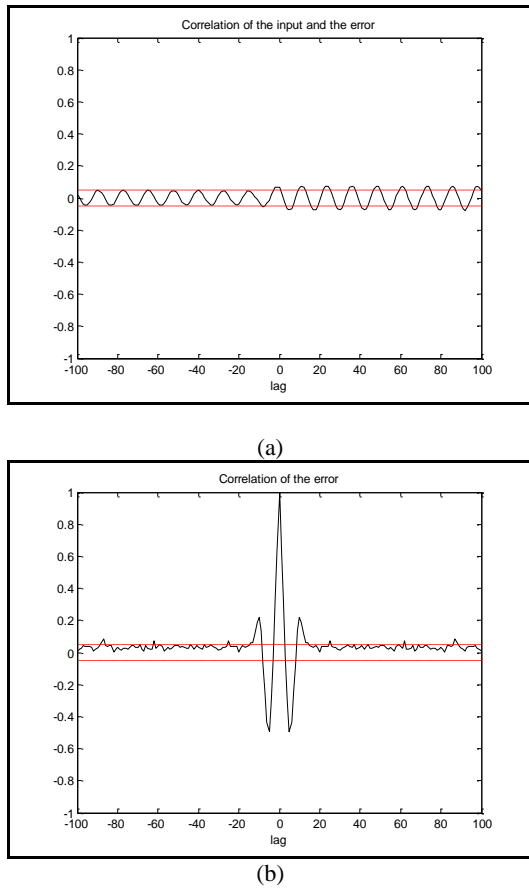

Fig. 8: Correlation tests (a) auto correlation; (b) cross correlation

4 Active Vibration Control

In this section, intelligent control schemes of the horizontal flexible plate structure are introduced. Active vibration control (AVC) technique was applied in this research to suppress the vibration on the plate system. The realization of AVC acted when the sensors applied in the system have detected the unwanted disturbances through the suitable controller in processing the vibration. The actuators were supplied with some information that will produce the secondary signal to superimpose the disturbance and interference with the primary signal, leading to the vibration cancellation (28). Proportional-Integral-Derivate (PID) controller is known as the best controller in process control due to its characteristics such as simplicity and higher robustness in wider operating condition (29). The block diagram of PID control scheme is shown in Figure 9.

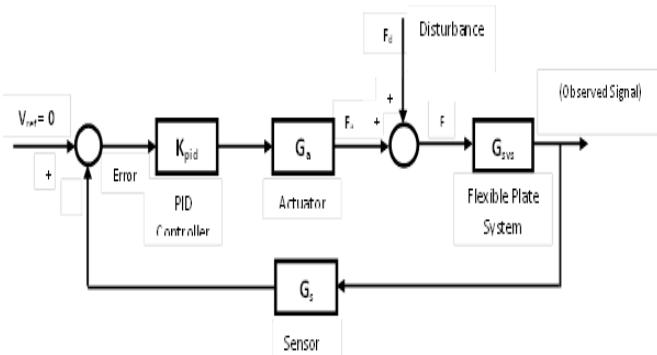

Fig. 9: The PID based controller scheme

The G_a , G_s , G and K are the transfer function of actuator, horizontal flexible plate system, sensor and controller parameters, respectively. Basically, the controller is forced to get the minimum error by reducing the error between the reference value and its actual value. The reference input which is the desired acceleration as

shown in the closed loop block diagram in Figure 9 is purposely set to zero in order to get zero cancellation in the system. $-G_s K_{pid} V$ is the input to the actuator while $F_a = -G_a G_s K_{pid} V$.

Then, the total force exerted into the horizontal flexible plate system is given by:

$$F = F_a + F_d = -G_a G_{sys} K_{pid} V + F_d \dots\dots (2)$$

Hence, the output of the horizontal flexible plate system, V_{out} can be described as:

$$V_{out} = G_{sys} F_d \frac{1}{(1 + G_a G_s K_{pid} G_{sys})} \dots\dots (3)$$

The controller gain, K_{pid} can affect the lateral vibration of flexible plate system, which the value of V_{out} is inversely proportional to the value of K_{pid} . By increasing the value of controller gain, the value of acceleration, V_{out} will be decreased and the amplitude of the undesired vibration in the system will be reduced. As stated by (30) the transfer function of sensor and actuator are assumed as unity for simulation work purpose. Hence, the equation (4) can be written as:

$$V_{out} = G_{sys} F_d \frac{1}{(1 + K_{pid} G_{sys})} \dots\dots (4)$$

There are several conventional methods in tuning the PID parameters. The most famous one is Ziegler-Nichols tuning rules method. This method has been widely used in many industrial applications. In 1942, Ziegler and Nichols developed two different types of tuning method which are known as the first and second methods. The first method is operated in the open loop system while the second method is operated in the close loop system. The second method is applied in this study for tuning the PID parameters of the system.

Initially, the value of integral gain, K_I and derivative gain, K_D are set as zero. Next, the value of proportional gain, K_P is tuned by increasing the value from zero until an optimum value of K_P is achieved. This optimum value can be defined as K_{cr} where the oscillation response is in the stable mode, and the oscillation frequency period at this stable mode can be defined as T_u . The values of PID parameters were calculated using the Ziegler-Nichols equation as tabulated in Table 3 (31). Figure 10 presents the sample of oscillation frequency period at stable mode where the ultimate gain, K_{cr} is set at 6.5.

Table 3: The set of parameters used to achieve the best performance in PSO

Controller	K_P	K_I	K_D
PID Controller	$0.6K_{cr}$	$P_{cr}/2$	$0.125P_{cr}$

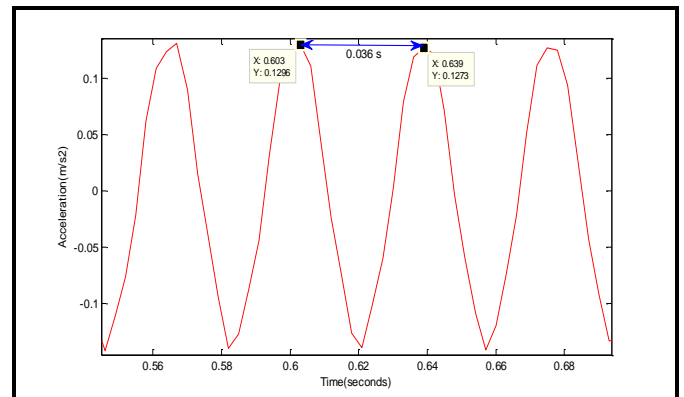

Fig. 10: The sustained oscillations with period $P_{cr} = 0.036$ s at K_{cr} is set to 6.5

5 Result and Discussions

The first analysis of the controller is conducted by exerting the system with a sinusoidal disturbance. The result obtained shows that the PID-ZN controller with sinusoidal disturbance has successfully give a good attenuation at the first mode of vibration by achieving 34.37 dB attenuation in the system. The controller reduces the attenuation value from 103.5 dB (before control) to 69.13 dB (after control), which the percentage of reduction achieved by the controller is 33.21%. The mean squared error achieved by the controller is 0.0183 as compared to the condition without controller, which is 0.6655. This shows that the controller does not only give the highest attenuation to the system, but has also successfully achieved the lowest mean squared error in the system.

The attenuation result for the PID-ZN controller under sinusoidal disturbance in the time domain is shown in Figure 11. Meanwhile, the attenuation result for the PID-ZN controller under sinusoidal disturbance in the frequency domain is illustrated in Figure 12. The PID parameters obtained using Ziegler-Nichols tuning rules and mean squared error achieved by the PID-ZN controller are listed in Table 4. Table 5 presents the attenuation level and percentage of reduction achieved by the PID-ZN controller under sinusoidal disturbance.

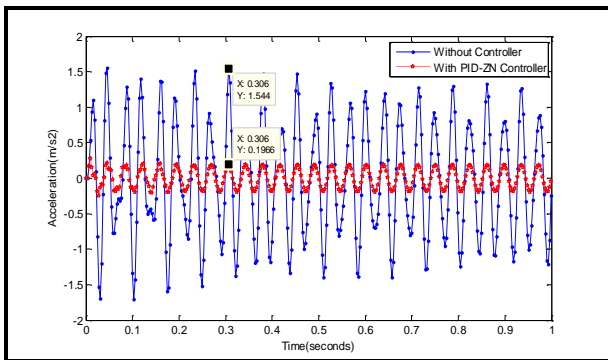

Fig. 11: The PID-ZN based controller in time domain under sinusoidal disturbance

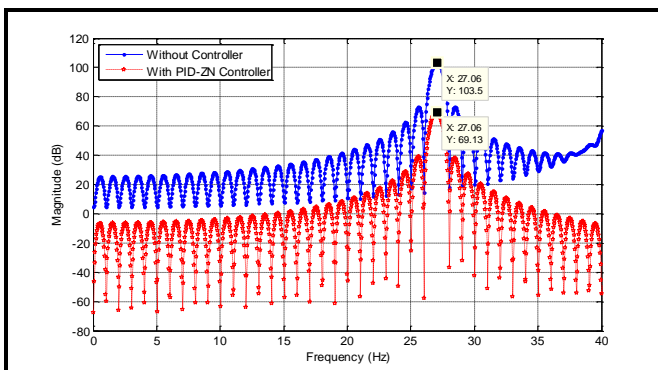

Fig. 12: The PID-ZN based controller in frequency domain under sinusoidal disturbance

Table 4: The PID parameters and MSE obtained tuned by ZN using sinusoidal disturbance

Controller	K_P	K_I	K_D	Mean Squared Error
Without Controller	-	-	-	0.6655
PID-ZN	3.9	0.02	0.05	0.0183

Table 5: The attenuation level achieved by PID-ZN controller with sinusoidal disturbance

Controller	Decibel Magnitude (dB)	Attenuation Level (dB)	Percentage of Reduction
	1 st mode	1 st mode	1 st mode
Without Controller	103.50	reference	reference
PID-ZN	69.13	34.37	33.21 %

In order to test the robustness of the developed controller, the analysis of PID-ZN controller is continued by exerting the multiple sinusoidal disturbances to the system. According to the obtained result, the PID-ZN controller under multiple sinusoidal disturbances has successfully controlled the unwanted vibration of the horizontal flexible plate system by achieving high attenuation level at the first mode of vibration. Figures 13 and 14 present the performance of PID-ZN controller under multiple sinusoidal disturbances in time and frequency domains, respectively.

The maximum attenuation achieved by PID-ZN controller is 34.30 dB. The controller reduced the attenuation value from 117.3 dB (before control) to 83.00 dB (after control), which the percentage of reduction achieved by the controller is 29.24%. The percentage of reduction achieved by the controller under multiple sinusoidal disturbances is lower than the controller under single sinusoidal disturbance. This is due to double disturbances that have been applied into the system. Therefore, the performance of the controller might be deteriorated. However, the PID-ZN controller performance under multiple sinusoidal disturbances is still reasonable and acceptable.

The controller also achieved the lowest mean squared error in the system, which the MSE is reduced from 2.6619 (before control) to 0.0734 (after control). This indicates that the controller does not only give the highest attenuation to the system, but has also successfully achieved the lowest mean squared error in the system. Besides, it is also observed that the magnitude of the signal in frequency response is different under multiple sinusoidal disturbances. This is probably due to the effect of the control action upon the vibrating system.

It is noticed that the biggest MSE achieved by the controller will affect the controller performance where the attenuation level achieved by the controller might be low as compared to the performance of the controller with low MSE value. Besides, the gain parameters obtained by the controller also will affect the performance of the controller itself. As mentioned by Kafader (2014), the low value of controller will result in a poor control behaviour. The mean squared error achieved by PID-ZN controller under multiple sinusoidal disturbances is listed in Table 6. Table 7 presents the attenuation level and percentage of reduction achieved by PID-ZN controller under multiple sinusoidal disturbances. In addition, it was found that the gain values obtained in this study are possible to be implemented into the real system, since the gain values are not too large. This statement is supported by Spearritt and Asokanathan (1996), where the large values of gain obtained by the controller cannot be implemented into the real system because it can shorten the lifetime of the actuator itself. Furthermore, it will ruin the actuator linearity at the certain point of the operating condition and indirectly bring instability to the system (Goldfarb and Sirithanapipat, 1999).

Table 6: The PID parameters and MSE obtained by ZN using multiple sinusoidal disturbances

Controller	K_P	K_I	K_D	Mean Squared Error
Without Controller	-	-	-	0.6655
PID-ZN	3.9	0.02	0.05	0.0183

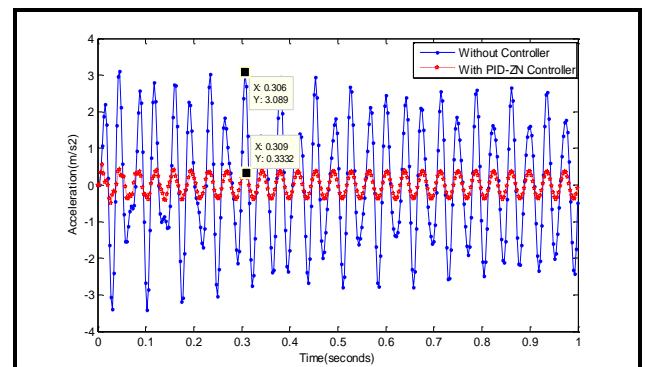

Fig. 13: The PID-ZN based controller in time domain under multiple sinusoidal disturbance

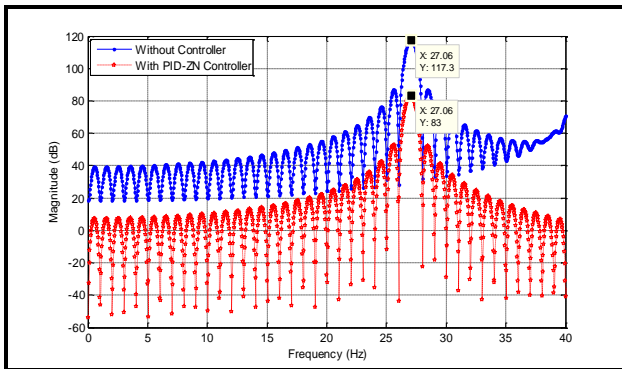

Fig. 14: The PID-ZN based controller in frequency domain under multiple sinusoidal disturbances

Table 7: The attenuation level achieved by PID-ZN controller with multiple sinusoidal disturbances

Controller	Decibel Magnitude (dB)	Attenuation Level (dB)	Percentage of Reduction
	1 st mode	1 st mode	1 st mode
Without Controller	117.30	reference	reference
PID-ZN	83.00	34.30	29.24 %

6 Conclusion

In this paper, a dynamic system model for horizontal flexible plate was developed using system identification technique using particle swarm optimization algorithm. The observed input-output data was acquired in the experiment. An experiment setup to conduct the experiment of vibration data collection was explained briefly in this paper. Furthermore, the result obtained in modelling the system was also being discussed and presented in this paper. It shows that the dynamic system of horizontal flexible plate was very well modelled by achieving the lowest mean squared error, good correlation tests and high stability in the pole-zero diagram. In addition, this paper also discussed the result for active vibration control of horizontal flexible plate system. The controller proposed in this study has been successfully suppressed the unwanted system vibration by achieving a good attenuation at the first mode of vibration with 34.37 dB attenuation. The percentage of reduction achieved by the controller is 33.21%.

Acknowledgement

The authors would like to express their gratitude to Universiti Teknologi Malaysia (UTM) and Universiti Teknologi Malaysia (UiTM) for funding the research and providing facilities to conduct this research.

References

- [1] Mat Darus IZ, Al-Khafaji AAM. Non-parametric modelling of a rectangular flexible plate structure. *Engineering Applications of Artificial Intelligence*. 2012;25(1):94-106.
- [2] Julai S, Tokhi MO, Mohamad M, Latiff IA, editors. Control of a flexible plate structure using particle swarm optimization. 2009 IEEE Congress on Evolutionary Computation; 2009: IEEE.
- [3] Lueg P. Process of silencing sound oscillations. Google Patents; 1936.
- [4] Tokhi MO, Hossain MA. Self-tuning active vibration control in flexible beam structures. *Proceedings of the Institution of Mechanical Engineers, Part I: Journal of Systems and Control Engineering*. 1994;208(4):263-78.
- [5] Mat Darus IZ, Tokhi MO. Soft computing-based active vibration control of a flexible structure. *Engineering Applications of Artificial Intelligence*. 2005;18(1):93-114.

- [6] Hashim MSZ, Tokhi M, Mat Darus I. Active vibration control of flexible structures using genetic optimisation. *Journal of low frequency noise, vibration and active control*. 2006;25(3):195-207.
- [7] Madkour A, Hossain MA, Dahal KP, Yu H. Intelligent learning algorithms for active vibration control. *IEEE Transactions on Systems, Man, and Cybernetics, Part C (Applications and Reviews)*. 2007;37(5):1022-33.
- [8] Marinaki M, Marinakis Y, Stavroulakis GE. Fuzzy control optimized by PSO for vibration suppression of beams. *Control Engineering Practice*. 2010;18(6):618-29.
- [9] Julai S, Tokhi MO, editors. SISO and SIMO active vibration control of a flexible plate structure using real-coded genetic algorithm. *Cybernetic Intelligent Systems (CIS), 2010 IEEE 9th International Conference on*; 2010: IEEE.
- [10] Caruso G, Galeani S, Menini L. Active vibration control of an elastic plate using multiple piezoelectric sensors and actuators. *Simulation Modelling Practice and Theory*. 2003;11(5):403-19.
- [11] Gardonio P, Bianchi E, Elliott S. Smart panel with multiple decentralized units for the control of sound transmission. Part I: theoretical predictions. *Journal of sound and vibration*. 2004;274(1):163-92.
- [12] Gardonio P, Bianchi E, Elliott S. Smart panel with multiple decentralized units for the control of sound transmission. Part II: design of the decentralized control units. *Journal of Sound and Vibration*. 2004;274(1):193-213.
- [13] Gardonio P, Bianchi E, Elliott S. Smart panel with multiple decentralized units for the control of sound transmission. Part III: control system implementation. *Journal of sound and vibration*. 2004;274(1):215-32.
- [14] Hu Q, Ma G, Li C, editors. Active vibration control of a flexible plate structure using LMI-based H^∞ output feedback control law. *Intelligent Control and Automation, 2004 WCICA 2004 Fifth World Congress on*; 2004: IEEE.
- [15] Tokhi MO, Hossain MA. A unified adaptive active control mechanism for noise cancellation and vibration suppression. *Mechanical systems and signal processing*. 1996;10(6):667-82.
- [16] Tavakolpour AR, Mat Darus IZ, Tokhi MO, Mailah M. Genetic algorithm-based identification of transfer function parameters for a rectangular flexible plate system. *Engineering Applications of Artificial Intelligence*. 2010;23(8):1388-97.
- [17] Mat Darus IZ. Soft computing adaptive Vibration control of flexible structures: Ph. D. Thesis, Department of Automatic control and System Engineering, University of Sheffield; 2004.
- [18] Shaheed MH, Tokhi MO, Chipperfield AJ, Azad AKM. Modelling and open-loop control of a single-link flexible manipulator with genetic algorithms. *Journal of Low Frequency Noise, Vibration and Active Control*. 2001;20(1):39-55.
- [19] Al-Khafaji AAM. Modeling and control of underwater flexible-link manipulator employing bio-inspired algorithms and PID-based control schemes: Universiti Teknologi Malaysia; 2016.
- [20] Md Salleh S, Tokhi MO, Julai S, Mohamad M, Latiff IA, editors. PSO-based parametric modelling of a thin plate structure. *Computer Modeling and Simulation, 2009 EMS'09 Third UKSim European Symposium on*; 2009: IEEE.
- [21] Noghrehabadi A, Ghalambaz M, Ghalambaz M, Vosough A. A hybrid power series—Cuckoo search optimization algorithm to electrostatic deflection of micro fixed-fixed actuators. *International Journal of Multidisciplinary Sciences and Engineering*. 2011;2(4):22-6.
- [22] Hadi MS, Mat Darus IZ, Yatim H, editors. Modeling flexible plate structure system with free-free-clamped-clamped (FFCC) edges using Particle Swarm Optimization. *Computers & Informatics (ISCI), 2013 IEEE Symposium on*; 2013: IEEE.
- [23] Abd Samad MF, Jamaluddin H, Ahmad R, Yaacod MS, Azad AKM. Effect of Penalty Function Parameter in Objective Function of System Identification. *International Journal of Automotive and Mechanical Engineering (IJAME)*. 2013:940-54.
- [24] Abdel-Raouf O, Abdel-Baset M. A new hybrid flower pollination algorithm for solving constrained global optimization problems. *International Journal of Applied Operational Research-An Open Access Journal*. 2014;4(2):1-13.
- [25] Azraai MR, Priyandoko G, Yusoff AR, Rashid MFFA. Parametric optimization of magneto-rheological fluid damper using particle swarm optimization. *International Journal of Automotive and Mechanical Engineering*. 2015;11:2591.
- [26] Mohd Yatim H. Evolutionary algorithms for active vibration control of flexible manipulator: Universiti Teknologi Malaysia; 2016.

- [27] Hadi MS, Mat Darus IZ. Intelligence swarm model optimization of flexible plate structure system. *International Review of Automatic Control (IREACO)*. 2013;6(3):322-31.
- [28] Leitch RR, Tokhi MO. Active noise control systems. *IEE Proceedings A-Physical Science, Measurement and Instrumentation, Management and Education-Reviews*. 1987;134(6):525-46.
- [29] Blevins TL. PID advances in industrial control. *IFAC Proceedings Volumes*. 2012;45(3):23-8.
- [30] Saad MS. Evolutionary optimization and real-time self-tuning active vibration control of a flexible beam system: *Universiti Teknologi Malaysia*; 2014.
- [31] Shahrudin NMR. Active vibration control of transverse vibrating segmented marine riser: *Universiti Teknologi Malaysia*; 2015.