

HARNESSING ENERGY VIA PIEZOELECTRICITY VIBRATION

TEH SUI LIN

A project report submitted in fulfilment of the
requirements for the awards of the degree of
Master of Engineering (Mechanical)

Faculty of Mechanical Engineering
Universiti Teknologi Malaysia

JUNE 2016

To my beloved family who always gives me strength to complete this thesis,
believe in me and guide me all of my pursuits.

ACKNOWLEDGEMENT

This dissertation would not have been possible without the guidance and help of several individuals who, in one way or another, contributed and extended their valuable assistance throughout the duration of this study.

First and foremost, it is with tremendous gratitude that I acknowledge the continual help and support of supervisors, Associate Professor Dr. Intan Zaurah Binti Mat Darus. The patience they have shown during encountered obstacles, along with the inspiration and expertise they provided will not be forgotten. The completion of this work would not have been possible without their recommendations and assurances.

Finally, my numerous friends in the UTM who provided encouragement and frequent relief during my study duration here must be mentioned. There are just too many to name individually here but I thank you all for the happy memories.

ABSTRACT

In an effort to eliminate the replacement of the batteries of electronic devices that are difficult or impractical to service once deployed, harvesting energy from mechanical vibrations or impacts using piezoelectric materials has been researched over the last several decades. However, a majority of these applications have very low input frequencies. This represents a challenge for the researchers to optimize the energy output of piezoelectric energy harvesters, due to the relatively high elastic moduli of piezoelectric materials used to date. This project reviews the current state of research on piezoelectric energy harvesting devices at low frequency (<100 Hz) applications using vibrating motor and the methods that have been developed to improve the power outputs of the piezoelectric energy harvesters. This project study is divided into two main parts which are simulation from the forced vibration data and laboratory experiment on vibrating motor. The simulation results show that as the acceleration magnitude increases, the average direct voltage also increases from 4.5 mV to 8.1mV and the average power output that could be harnessed also increased from 22.5 μ W to 40.5 μ W. The experimental work energy harvesting structures focused on a bimorph piezoelectric rectangular plate (two faced PZT layer bonded to a brass substrate) that would be driven by ambient vibration source (motor). Multiple tip mass values on the effect of power generated were investigated in this project. It is shown that motor speed at 100 rpm has the highest power generated both with (1667.21 μ W) and without (10.15 μ W) the addition of tip mass. Besides, it is also observed as the motor speed increased from 900 rpm to 1000 rpm, lower tip mass values were required to optimize the power generated. 20g of tip mass value is required to generate 218.21 μ W at motor speed 900 rpm, 10g of tip mass value is required to generate 626.29 μ W at motor speed 1200 rpm. These power outputs are sufficient for low powered electronics which can be used in a variety of applications as indicated in the literatures reviewed.

ABSTRAK

Dalam usaha untuk menghapuskan penggantian bateri peranti elektronik yang sebenar sukar atau tidak praktikal untuk perkhidmatan sekali digunakan, tenaga penuaian dari getaran mekanikal atau kesan menggunakan bahan-bahan piezoelektrik telah dikaji sejak beberapa dekad yang lalu. Walau bagaimanapun, majoriti aplikasi mempunyai frekuensi input yang sangat rendah. Ini merupakan satu cabaran bagi para penyelidik untuk mengoptimumkan output tenaga penuai tenaga piezoelektrik, kerana modulus elastik yang agak tinggi bahan-bahan piezoelektrik digunakan setakat ini. Projek ini mengkaji keadaan semasa penyelidikan mengenai piezoelektrik peranti penuaian tenaga pada frekuensi rendah (<100 Hz) aplikasi yang menggunakan bergetar motor dan kaedah yang telah membangunkan untuk meningkatkan output kuasa Penuai tenaga piezoelektrik. Kajian projek dibahagikan kepada dua bahagian utama iaitu simulasi daripada data getaran paksa dan eksperimen makmal ke atas bergetar motor. Keputusan simulasi menunjukkan bahawa sebagai magnitud kenaikan pecutan, voltan langsung purata juga meningkat daripada 4.5 mV kepada 8.1 mV dan output kuasa purata yang boleh dimanfaatkan juga meningkat daripada 22.5 μ W kepada 40.5 μ W. Struktur penuaian tenaga kerja eksperimen memberi tumpuan kepada bimorph plat segi empat tepat piezoelektrik (dua dihadapi lapisan PZT terikat kepada substrat tembaga) yang akan dipacu oleh sumber getaran ambien (motor). Pelbagai nilai berat hujung atas kesan kuasa yang dihasilkan telah disiasat dalam projek ini. Ia menunjukkan bahawa kelajuan motor pada 1000 rpm mempunyai kuasa yang paling tinggi yang dihasilkan dengan kedua-dua (1667.21 μ W) dan tanpa (10.15 μ W) penambahan berat hujung. Selain itu, ia juga diperhatikan sebagai kelajuan motor meningkat daripada 900 rpm kepada 1000 rpm, lebih rendah nilai hujung berat yang diperlukan untuk mengoptimumkan kuasa yang dijana. 20 g nilai berat hujung diperlukan untuk menjana 218.21 μ W pada kelajuan motor 900 rpm, 10 g nilai berat hujung diperlukan untuk menjana 626.29 μ W pada kelajuan motor 1200 rpm ini output kuasa yang mencukupi untuk

elektronik berkuasa rendah yang boleh digunakan dalam pelbagai aplikasi seperti yang dinyatakan dalam literatur dikaji semula.

TABLE OF CONTENT

CHAPTER	TITLE	PAGE
	DECLARATION	II
	DEDICATION	III
	ACKNOWLEDGEMENT	IV
	ABSTRACT	V
	ABSTRAK	VI
	TABLE OF CONTENT	VIII
	LIST OF FIGURES	XII
	LIST OF TABLES	XVIII
	LIST OF SYMBOLS	XIX
	LIST OF ABBREVIATIONS	XXI
1	INTRODUCTION	1
	1.1 Motivation and contribution of the thesis	4
	1.2 Objective	6
	1.3 Scopes	6

CHAPTER	TITLE	PAGE
	1.4 Methodology	6
	1.5 Project Activities	8
2	LITERATURE REVIEW	10
	2.1 Fundamental of power harvesting	10
	2.2 Source of power harvesting	12
	2.2.1 Solar	12
	2.2.2 Air Flow	13
	2.2.3 Thermal	14
	2.2.4 Mechanical: Vibrations and Human Movement	15
	2.3 Mechanical vibration	16
	2.3.1 Electromagnetic	17
	2.3.2 Electrostatic	17
	2.3.3 Piezoelectric	18
	2.4 Piezoelectricity and piezoelectric materials	19
	2.4.1 Basic description of the Piezoelectric Effect	20
	2.4.2 Piezoelectric materials	23
	2.4.3 System components	24
	2.4.4 Harvesting Circuits	29
	2.5 Piezoelectric power generator	37
	2.6 Strategies to enhance energy harvesting	38
	2.6.1 Tuned or Wideband Piezoelectric Harvesters	38
	2.6.2 Effect of Piezoelectric constant	42
	2.6.3 Effect of Compliance	42
	2.6.4 Effect of Relative Permittivity	43
	2.6.5 Effect of the mechanical damping	44

CHAPTER	TITLE	PAGE
	2.6.6 Durability of Piezoelectric Harvesters	44
	2.6.7 Tip mass Effect on the harvester dynamics	45
	2.7 Usage Criteria	45
	2.8 Applications	46
3	RESEARCH METHODOLOGY	49
	3.1 Simulation Setup	49
	3.1.1 Piezoelectric Sensing Element	49
	3.1.2 Harnessing Circuit	50
	3.2 Data Acquisition System (DAQ)	52
	3.2.1 Flow of Information in DAQ	53
	3.3 Test Equipment	54
	3.3.1 Vibrating Mechanical Equipment	54
	3.3.2 Piezoelectric generator	55
	3.3.3 Tip mass	57
	3.3.4 NI Compact-data Acquisition Unit	57
	3.3.5 Processor and LabVIEW	59
	3.3.6 Harnessing Circuit	59
	3.4 Energy Storage Selection	60
	3.5 Experimental Setup	60
	3.5.1 Experimental Procedure	61
4	RESULT AND DISCUSSION	62
	4.1 Simulation Result and Analysis	62
	4.2 Experiment Result and Analysis	67
	4.2.1 Result of motor speed at 900 rpm	67

CHAPTER	TITLE	PAGE
	4.2.2 Result of motor speed at 1000 rpm	70
	4.2.3 Result of motor speed at 1100 rpm	73
	4.2.4 Result of motor speed at 1200 rpm	75
	4.3 Overall Analysis	82
5	CONCLUSION AND RECOMMENDATIONS	84
	5.1 Conclusion	84
	5.2 Recommendations	85
	REFERENCES	86

LIST OF FIGURES

FIGURE NO	TITLE	PAGE
1.1	Vibration energy harvesting system components.	3
1.2	General block diagram of an energy scavenging system[3].	4
1.3	Methodology of the study	7
1.4	Gantt chart for Master Project 1	8
1.5	Gantt chart for Master Project 2	9
2.1	Comparison of power from solar, vibrations and various batteries [2]	11
2.2	The electromagnetic generator design [13]	17
2.3	Different configurations of electrostatic transducers (A) In-Plane Overlap Varying, (B) In-Plane Gap Closing and (C) Out-Of-Plane Gap Closing[14]	18
2.4	Steps in poling a piezoelectric material (A) Random orientation of polar domains prior to polarization, (B) Polarization in dc electric field, and (C) Remnant polarization after electric field removed[5].	19
2.5	Visual representation of coupling between physical domains.	20
2.6	Piezoelectricity enables conversion from mechanical energy into electric energy and vice versa[16].	21
2.7	Direct Piezo-Effect: (A) At Applied Compression Stress, (B) At applied tension	21
2.8	Inverse piezo-effect at applied electric field	22
2.9	Schematic representation of a piezoelectric harvester [11].	25
2.10	The direct and indirect methods demonstrated on an	

FIGURE NO	TITLE	PAGE
	electric motor, piezo elements in grey [11].	26
2.11	(A) Side view of four bar magnet harvester, (B) Front view, (C) Schematic of magnetic levitation harvester [22].	27
2.12	Schematic of power harvesting components and scope of this thesis [11].	29
2.13	(A) Diode-connected, (B) V_t -cancelled, and (C) Feedback-enhanced transistors used in full-wave (D) Diode-based and (E) Cross-coupled rectifiers [24].	29
2.14	Measured peak-to-peak output as a function of input frequency.	31
2.15	Non-adaptive harvesting circuit for battery storage.	33
2.16	Ottman's adaptive harvesting circuit [28].	34
2.17	Comparison of harvested power ($V_{oc} = 21V - 67V$) [28]	34
2.18	Estimation of harvested efficiency of non-adaptive circuit [28].	35
2.19	Parallel power compensation topology [29].	36
2.20	Series power compensation topology [29].	36
2.21	Classic interface	37
2.22	Synchronized switch harvesting on inductor circuit	37
2.23	Working modes of piezoelectric power harvester.	38
2.24	Six methods of achieving wideband or tunable piezoelectric vibration energy harvesters[9].	39
2.25	Trapezoidal beams [4][32].	40
2.26	Various configurations of piezoelectric cantilevers : (A) Unimorph; (B) Bimorph; (C) A Piezoelectric Cantilever With Interdigitated Electrodes; (D) A Piezoelectric Cantilever With Proof Mass At Its Free End [33].	41
2.27	Effect of the piezoelectric constant on the output power and the optimal load resistance [7].	42
2.28	Effect of the elastic compliance on the output power and the optimal load resistance [11].	43

FIGURE NO	TITLE	PAGE
2.29	Effect of the relative permittivity on the output power and the optimal load resistance [11].	43
2.30	Effect of the tip mass on the output voltage and the resonance frequency [11].	45
3.1	Block diagram for piezoelectric accelerometer	50
3.2	Sensing element of piezoelectric accelerometer developed using MATLAB Simulink	50
3.3	Non-adaptive harnessing circuit (Mingjie And Wei-Hsin, 2005)	51
3.4	Non-adaptive harnessing circuit developed using MATLAB Simulink	52
3.5	Block diagram of data acquisition system(DAQ)	53
3.6	Experimental setup layout	54
3.7	Vibrating equipment, motor model used in the experiment.	55
3.8	Double-sided pzt piezo ceramic generator P5-1	56
3.9	Piezoelectric generator dimension at 70 mm x 20 mm x 0.6 mm.	56
3.10	Tip mass at 5g each.	57
3.11	Ni Compact-Data Acquisition Unit	57
3.12	Ni-9234 Module	58
3.13	Harnessing Circuit	59
3.14	Capacitor	60
3.15	Experimental Setup	60
3.16	Piezoelectric Generator (A)without tip mass and (B) without tip mass.	61
4.1	Acceleration versus time at different amplitude of 0.05 V_{pp} .	63
4.2	Acceleration versus time at different amplitude of 0.10 V_{pp} .	63
4.3	Acceleration versus time at different amplitude 0.15 V_{pp} .	64
4.4	Voltage versus time at different amplitude of 0.05 V_{pp} .	65

FIGURE NO	TITLE	PAGE
4.5	Voltage versus time at different amplitude of 0.10 V _{pp} .	65
4.6	Voltage versus time at different amplitude of 0.15 V _{pp} .	66
4.7	Voltage versus time for motor speed at 900 rpm with no proof mass.	67
4.8	Voltage versus time for motor speed at 900 rpm with 5g proof mass.	68
4.9	Voltage versus time for motor speed at 900 rpm with 10g proof mass.	68
4.10	Voltage versus time for motor speed at 900 rpm with 15g proof mass.	68
4.11	Voltage versus time for motor speed at 900 rpm with 20g proof mass.	69
4.12	Voltage versus time for motor speed at 900 rpm with 25g proof mass.	69
4.13	Voltage versus time for motor speed at 900 rpm with 30g proof mass.	69
4.14	Voltage versus time for motor speed at 900 rpm with 35g proof mass.	70
4.15	Voltage versus time for motor speed at 1000 rpm with no proof mass.	70
4.16	Voltage versus time for motor speed at 1000 rpm with 5g proof mass.	70
4.17	Voltage versus time for motor speed at 1000 rpm with 10g proof mass.	71
4.18	Voltage versus time for motor speed at 1000 rpm with 15g proof mass.	71
4.19	Voltage versus time for motor speed at 1000 rpm with 20g proof mass.	71
4.20	Voltage versus time for motor speed at 1000 rpm with 25g proof mass.	72
4.21	Voltage versus time for motor speed at 1000 rpm with 30g	

FIGURE NO	TITLE	PAGE
	proof mass.	72
4.22	Voltage versus time for motor speed at 1000 rpm with 35g proof mass.	72
4.23	Voltage versus time for motor speed at 1100 rpm with no proof mass.	73
4.24	Voltage versus time for motor speed at 1100 rpm with 5g proof mass.	73
4.25	Voltage versus time for motor speed at 1100 rpm with 10g proof mass.	73
4.26	Voltage versus time for motor speed at 1100 rpm with 15g proof mass.	74
4.27	Voltage versus time for motor speed at 1100 rpm with 20g proof mass.	74
4.28	Voltage versus time for motor speed at 1100 rpm with 25g proof mass.	74
4.29	Voltage versus time for motor speed at 1100 rpm with 30g proof mass.	75
4.30	Voltage versus time for motor speed at 1100 rpm with 35g proof mass.	75
4.31	Voltage versus time for motor speed at 1200 rpm with no proof mass.	75
4.32	Voltage versus time for motor speed at 1200 rpm with 5g proof mass.	76
4.33	Voltage versus time for motor speed at 1200 rpm with 10g proof mass.	76
4.34	Voltage versus time for motor speed at 1200 rpm with 15g proof mass.	76
4.35	Voltage versus time for motor speed at 1200 rpm with 20g proof mass.	77
4.36	Voltage versus time for motor speed at 1200 rpm with 25g proof mass.	77

FIGURE NO	TITLE	PAGE
4.37	Voltage versus time for motor speed at 1200 rpm with 30g proof mass.	77
4.38	Voltage versus time for motor speed at 1200 rpm with 35g proof mass.	78
4.39	Average voltage versus proof mass weight at various motor speed of 900 rpm, 1000 rpm, 1100 rpm and 1200 rpm.	79
4.40	The average voltage versus vibrating motor speed at different tip mass.	80
4.41	The summary of alternate voltage (blue line) and direct average voltage (red line).	83

LIST OF TABLES

TABLE NO	TITLE	PAGE
1.1	Comparison of energy sources [1][2].	2
1.2	Power density, reported in literature, of three energy transducers used to convert the energy of the mechanical vibrations.	4
2.1	Advantages and disadvantages of solar power [9].	12
2.2	Advantages and disadvantages of air flow energy harvesters [9].	13
2.3	Advantages and disadvantages of thermal energy harvesters	14
2.4	Advantages and disadvantages of mechanical energy harvesters	15
2.5	A number of transduction mechanism suitable for power harvesting [11].	16
2.6	Summary of the comparison of the three conversion mechanism for energy harvesting [7].	19
2.7	Properties of some piezoelectric materials [19].	24
3.1	Specification of the pzt piezo-ceramic generator P5-1	56
4.1	Summary of simulation results	67
4.2	Summary of the voltage, current and power data at different motor speed and proof mass weight applied	79
4.3	Summary of maximum voltage generated.	81
4.4	The ratio of the direct voltage generated and peak voltage generated from the system.	82

LIST OF SYMBOLS

$^{\circ}\text{C}$	-	Celsius
Ω	-	Ohm
ε	-	Induced emf, Dielectric constant
ε_0	-	Dielectric constant of free space, Permittivity of free space
A	-	Ampere
a	-	Acceleration
C	-	Capacitance
c	-	Electric constant
D	-	Electrical displacement (charged density)
d	-	Gap or distance between plates; Piezoelectric strain coefficient
dB	-	Decibel
E	-	Electric field
f	-	Frequency
Hz	-	Hertz
I, i	-	Current
k	-	Coupling coefficient; Piezoelectric constant
L^2	-	Free vibrating part
m	-	Meter
Q	-	Charge on capacitor
R	-	Resistance
rpm	-	Revolution per minute
s, sec	-	Second
t	-	Thickness
V, Volt	-	Voltage
V_D	-	Voltage Drop
V_{avg}	-	Direct average Voltage
V_p	-	Peak Voltage

V_{pp}	-	Peak to peak Voltage
W	-	Watt
Y	-	Modulus of elasticity (Young's Modulus)

LIST OF ABBREVIATIONS

A/D	-	Analog to Digital
AC	-	Alternate Current
AI	-	Analog Input
AO	-	Analog Output
BaTiO ₃	-	Barium Tinate
D/A	-	Digital to Analog
DAQ	-	Data Acquisition System
DC	-	Direct Current
DIO	-	Digital I/O
i/O	-	Input to Output
NI	-	National Instrumentation
PVDF	-	Polyvinylidene Fluoride
PZT	-	Lead Zirconate Tinate

CHAPTER 1

INTRODUCTION

Sensors that can be used in remote or not easily accessible places are becoming an attractive solution in a wide variety of applications such as habitat or structural monitoring.

The limitations in providing power with batteries have led to a growing interest in “energy harvesting”. Energy harvesting is a technology that converts the excess energy available in an environment into usable energy for low power electronics. The term harvest and harness are used concurrently in this thesis.

It shows that for short periods (months to a year) fixed energy content methods such as batteries or fuel cells are sufficient. Fixed energy methods possess a given amount such as quantity of fuel or a battery without any charging equipment. As the desired lifespan increases the constant output energy harvesting methods become interesting. These are systems of which the output is constant amount of power, consider solar cells under constant illumination or windmills under constant wind conditions, vibratory sources are an excellent alternative.

Some battery types and most applicable energy conversion mechanisms are compared with respect to their long term and short term power densities. Power density, meaning the amount of average energy generated per unit time and volume, is the most convenient and widely used criterion in the literature.

According to Table 1.1, batteries are reasonable for one year applications, whereas energy harvesters are required for long lifetime applications.

Table 1.1 : Comparison of energy sources.[1][2]

	Power density ($\mu\text{W}/\text{cm}^3$)	
	One year lifetime	Ten year lifetime
Solar (outdoors)	15,000 - Direct sun; 150 - Cloudy day	15,000 - Direct sun; 150 - Cloudy day
Solar (indoors)	6 - Office desk	6 - Office desk
Vibrations (piezoelectric conversion)	250	250
Vibrations (electrostatic conversion)	50	50
Acoustic noise	0.003 at 75dB; 0.96 at 100dB	0.003 at 75dB; 0.96 at 100dB
Temperature gradient	15 at 10°C	15 at 10°C
Shoe inserts	330	330
Batteries:non-rechargeable lithium	45	3.5
Batteries:rechargeable lithium	7	0
Hydrocarbon fuel:micro heat engine	333	33
Fuel cells:methanol	280	28

In Figure 1.1, components of a vibration energy harvesting system are depicted. This flow chart can be generalized for all energy harvesting systems in which an energy source, a conversion device, a conditioning circuit and an electric load are the main components of the general energy harvesting system.

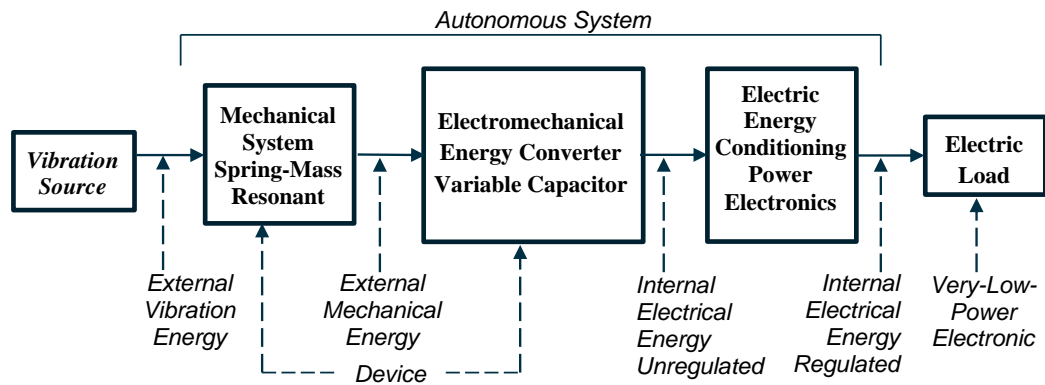

Figure 1.1 : Vibration Energy Harvesting System Components.

The general system basically aims to accomplish five consecutive tasks[1]:

- Collecting the maximum energy from the energy source
- Converting the ambient energy into electric energy efficiently
- Rectifying and storing the maximum amount of electric energy
- Regulating the output voltage level depending on the application
- Transmitting the electric energy to the load when it is required

The contribution of this thesis is mainly based on implementing the active energy harvesting concept. An energy scavenging system can be partitioned in two sections: the energy-scavenger itself and the electronic interface. The first one is the energy transducer while the second one is the electronic circuit which manages the energy. One of the most important objectives of the electronic interface is to realize the required ac-dc conversion. Since the output power level of the energy-scavenger can be very low, the conversion should be as efficient as possible.[3]

The electronic interface can be divided in three subsystems as shown in the fig Figure 1.2 a) the ac-dc converter, b) the energy storage and c) the adapter. The last one supplies a regulated voltage to the load even when it sinks a time dependent energy during its work cycle. Furthermore, to obtain the maximum transfer of the energy from the energy scavenging system into the load, an optimum value of the output impedance exists [3].

Besides the working principle, the main difference between the various transducers is the scavenged power per cubic centimeter. In Table 1.1, the power density of the three transducers are shown: it is clear that the piezoelectric one is the most efficient. Furthermore its power density is compatible with the power consumption of modern wireless sensor nodes [3].

Table 1.2 : Power density, reported in literature, of three energy transducers used to convert the energy of the mechanical vibrations.

Working Principle of the Energy-Scavenger	Power-Density [$\mu\text{W}/\text{cm}^3$]
Electromagnetic	10
Electrostatic	50
Piezoelectric	250

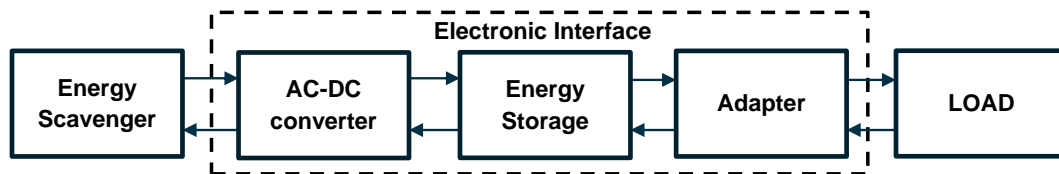

Figure 1.2 : General block diagram of an energy scavenging system.[3]

1.1 Motivation and contribution of the thesis

Power harvesting is a practice that has been widely used in developing devices that are self-powered and refers to the technique of acquiring energy from the environment and convert it into useful energy.

Due to increased demand relative to the mobility of electronic devices, the field of research in regarding alternative ways of low power energy generation has increased in recent years. Moreover, the evolution of battery technology remained practically stagnant over the past decade in relation to computer system.

In the past decades, several systems have been developed using smart materials. Typically, piezoelectric materials are used commercially as motion sensors or amounting to force. The piezoelectric crystals are transducer elements for accelerometers, actuators, dynamic pressure sensors and load cells. Power supply is a limiting factor in wearable devices since the employment of a primary battery (a battery to be used only once) means that the user of the portable product has to carry an extra battery while the use of secondary battery (rechargeable battery) means that the user has to plug in the portable product to grid to recharge it. This fact limits the mobility of the wearable device which is restricted to the lifetime of the battery. Furthermore, due to the costs and inaccessible locations, the replacement or recharging of batteries is often not feasible for wearable devices integrated in smart clothes. Moreover, the increasing number of battery-powered portable products is creating an important environmental impact.

Nowadays, wireless sensor networks are drawing much attention in monitoring and controlling plants, resources and infrastructures. A critical component of the wireless sensor network is the power supply. If power is supplied through cables, the wireless network will not be truly wireless. Therefore, traditional batteries are usually used in wireless sensor networks. But in many applications, replacing batteries, due to their limited lifetime, is very inconvenient. The labor and cost associated with changing hundreds or thousands of batteries would be troublesome and expensive in maintaining the network.

Through piezoelectric energy harvesting has been thoroughly investigated since the late 1990s, it still remains an emerging technology and critical area of interest. Energy harvesting application fields so far mainly focused on low power devices due to their limited transduction efficiencies. To date, researchers are following distinct ways in developing piezoelectric energy harvesting technology. New materials, configuration approaches and operating modes are under study, and some of these valuable solutions were proposed in order to achieve large bandwidth harvesters that are able to scavenge energy from diverse environments [4].

1.2 Objective

The objective of this project is to design, simulate and develop an instrumentation to harness energy from micro vibration using smart materials.

1.3 Scopes

Aiming at a vibration based piezoelectric energy harvester, the research can be divided into 2 phases, that is, harvester and its host structure.

For the host structure, the acceleration magnitude is considered both in the simulation and the experiment work. Different motor speed is used to conduct the experiment work.

For the harvester, the designing in the mechanical system is focused in the experiment. The external mass is added to the harvester tip end is the main concern of this work to optimize the power output.

1.4 Methodology

The methodologies involved in this study are shown in Figure 1.4. The project starts by collecting reading materials specifically on sources of vibration, methods of converting ambient vibration energy into electrical energy, types of piezoelectric material, piezoelectric energy harnessing circuit, strategies used to optimize the power harvested and their applications.

The study on piezoelectric energy harnessing has been divided into two main parts which are (1) simulation of the vibration environment and (2) laboratory experiment on vibrating mechanical equipment. Both simulation and laboratory experiment will undergo the same process such as piezoelectric vibration to

electricity conversion, rectification and energy storage. For the experiment, the power generated with the aid of tip mass was studied.

The vibration data acquired from experimental study by previous researcher in order to determine the possible amount of power density output that can be produced for the specific acceleration input. With the promising amount of power density output produced during simulation, the laboratory experiment on vibrating mechanical equipment will be conducted by vibrating mechanical equipment and identifying electronic devices that can fully utilize this power.

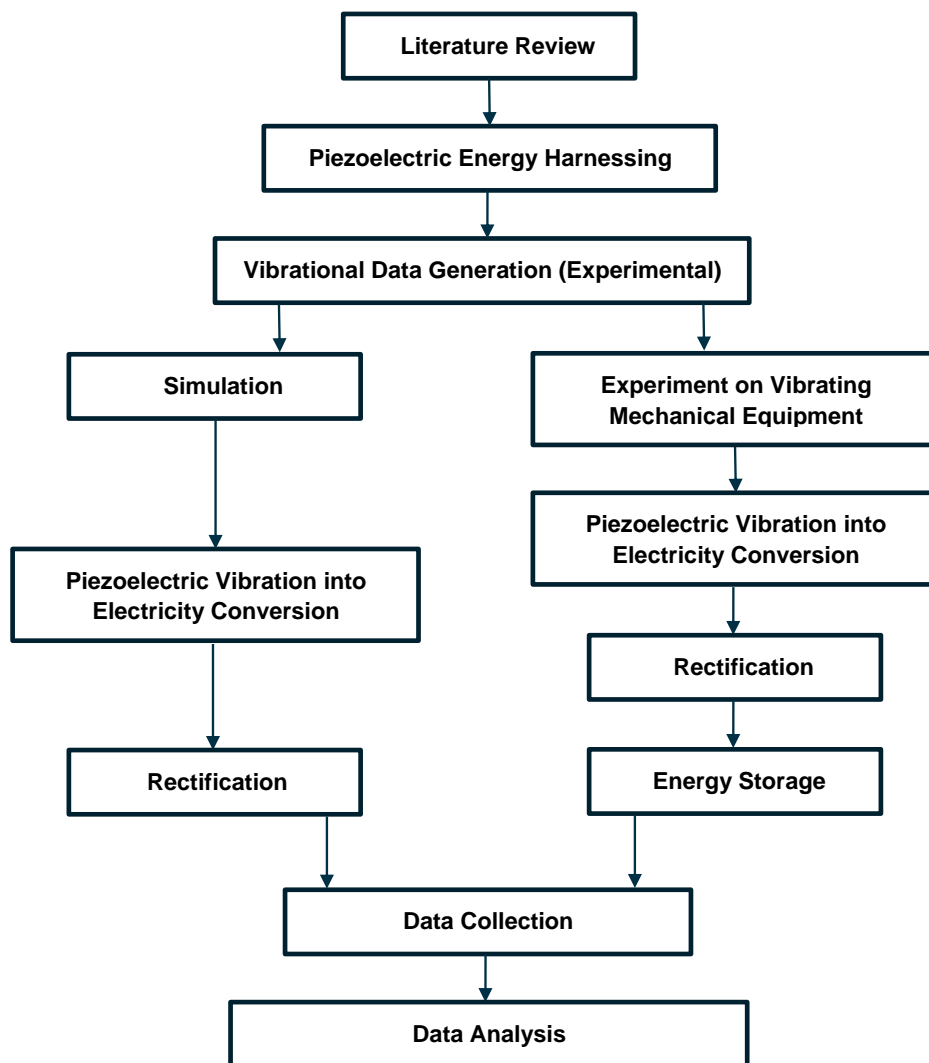

Figure 1 3 : Methodology of the study

1.5 Project Activities

NO	ACTIVITIES	WEEKS															
		1	2	3	4	5	6	7	8	9	10	12	13	14	15	16	
1	Selection of project title	■	■														
2	Collecting reading materials			■	■	■	■	■									
3	Literature review of previous research				■	■	■	■	■	■	■	■	■	■	■		
4	Understanding the concept of piezoelectric energy harnessing from vibration				■	■	■	■	■	■							
5	Familiarization with MATLAB Simulink					■	■	■	■	■	■						
6	Simulation of vibration environment using data acquired by previous researcher									■	■	■	■				
7	Simulation of energy harnessing										■	■	■				
8	Analysis of the results from the simulation of energy harnessing											■	■	■			
9	Report writing							■	■	■	■	■	■	■	■		
10	Preparation for seminar presentation													■	■		
11	Seminar 1															■	

Figure 1.4 : Gantt chart for Master Project 1

NO	ACTIVITIES	WEEKS															
		1	2	3	4	5	6	7	8	9	10	12	13	14	15	16	
1	Literature Review																
2	Experimental setup: Integration and development of data acquisition and instrumentation system																
3	Experiment on vibrating mechanical equipment																
4	Analysis of the experimental results																
5	Report writing																
6	Preparation for seminar presentation and submission of draft thesis																
7	Seminar 2																
8	Submission of the thesis																

Figure 1.5 : Gantt chart for Master Project 2

REFERENCES

- [1] Gurkan K. 2006. "Energy Harvesting for MEMS". University of Minnesota. Twin Cities.
- [2] Roundy S, Wright, and . 2005. "A study of low level vibrations as a power source for wireless sensor nodes.". *Computer communications*. 26: 1131-1144
- [3] Dallago E, Frattini G, Miatton D, Ricotti G and Venchi G. 2007. "Integrable High Efficiency AC-DC Converter For Piezoelectric Energy Scavenging System". *Proc. IEEE International Conference Portable Information Devices*. Italy.
- [4] Renato C, Udaya BR, Domenico C, Mario M, Cesare S, Gianluca dP & Calogero MO. 2014. "Piezoelectric Energy Harvesting Solutions". *Journal of Sensors*. 14: 4755-4790. DOI: 10.3390/s140304755.
- [5] Rupesh P. 2012. "Modelling, Analysis and Optimisation of Cantilever Piezoelectric Energy Harvesters". Doctor of Philosophy's thesis. The University of Nottingham
- [6] Mak KH. 2011. "Vibration Modelling and Analysis of Piezoelectric Energy Harvesters,". Doctor of Philosophy's thesis. University of Nottingham
- [7] Farbod K. 2011. "Vibration Based Piezoelectric Energy Harvesting System For Rotary Motion Applications". Master's Thesis. Simon Fraser University
- [8] Randall, Julian F. 2005. "Designing indoor solar products: photovoltaic technologies for AES". Chichester: John Wiley.
- [9] Emma LW. 2010. "Piezoelectric Energy Harvesting: Enhancing Output by Device Optimisation and Circuit Techniques". Doctor of Philosophy's thesis. Cranfield University

- [10] Chen CT, Islam RA and Priya S. 2006. "Electric energy generator". *IEEE Trans. Ultrason. Ferroelectr. Fre. Control.* 53(3): 656-661
- [11] Pieter HJ. 1983. "Power Harvesting Using Piezoelectric Materials Applications in Helicopter Rotors". Doctor of Philosophy's thesis. University of Twente
- [12] Mitcheson P, Stark B, Miao P, Yeatman E, Holmes, A and Green T. 2003. "Analysis and optimisation of MEMS electrostatic on-chip power supply for self powering of slow sensor". Eurosensor, Portugal.
- [13] El-Helmi M, Glynne J, James E, Beeby SP, White NM, Brown AD, Ross JN and Hill M. 2001. "Design and fabrication of a new vibration-based electromechanical power generator". *Sensor Actuators A.* 92: 335-42
- [14] Beeby SP, Tudor MJ and White NM. 2006. "Energy harvesting vibration sources for microsystems applications". *Journal of Measurement Science and Technology.* 17: 175-195
- [15] Carolina MAL & Carlos AG. 2014. "A Review of Piezoelectrical Energy Harvesting and Applications". *IEEE.* 1284-1288.
- [16] Jan H & Pim G. 2013. "An Introduction to Piezoelectric Materials and Applications". Stichting Applied Piezoelectric. Netherland.
- [17] Sadano HA & Daniel JI. 2004. "A Review of Power Harvesting from Vibration Using Piezoelectric Materials". *Journal of The Shock and Vibration Digest.* 36(3):197-205.
- [18] Dineva P. 2014. "Dynamic Fracture of Piezoelectric Materials, Solid Mechanics and its Applications". Springer International Publishing. Switzerland.
- [19] Dongna S. 2009. "Piezoelectric Energy Harvesting Devices for Low Frequency Vibration Applications". Doctor of Philosophy's thesis. Auburnn University
- [20] Liu K, Ren KL, Hofmann H and Zhang Q. 2005. "Investigation of electrostrictive polymers for energy harvesting". *IEEE Transactions on Ultrasonics, Ferroelectrics, and Frequency Control.* 52(12): 2411-2417
- [21] Geng T. 2008. "Active Energy Harvesting On Piezoelectric Materials: Experimental Demonstration and Standalone Circuit Implementation". Master's Thesis. The Pennsylvania State University.

- [22] Anthony M, Yongke Y & Shashank P. 2012. "Combinatory Piezoelectric and Inductive Vibration Energy Harvesters". IEEE.
- [23] Salem S & Othman S. 2011. "Environmental Vibration Based MEMS Piezoelectric Energy Harvester". Journal of IEEE Computer Society. 87: 511-514.DOI: 10.1109/DeSE.2011.87.
- [24] Dongwon K and Gabriel ARM. "A Rectifier Free Piezoelectric Energy Harvester Circuit". Linear Technology Corporation., Milpitas, CA.
- [25] Triet TL, Jifeng H, Annette VJ, Kartikeya M, and Terri SF. 2006. "Piezoelectric Micro-power Generation Interface Circuits". IEEE Journal of Solid State Circuits. 41(6):1411-20.DOI: 10.1109/JSSC.2006.874286.
- [26] Geffrey KO, Heath FH & George AL. 2002. "Adaptive Piezoelectric Energy Harvesting Circuit for Wireless Remote Power Supply". IEEE Transaction on Power Electron. 17(5):669-76.DOI: 10.1109/TPEL.2002.802194..
- [27] Dallago E, Miatton D, Venchi G, Bottarel V, Freattini G. 2008. "Active Self Supplied AC-DC Converter for Piezoelectric Energy Scavenging Systems with Supply Independent Bias". Proc. IEEE International Symposium Circuits and Systems. 1448-1451.
- [28] Mingjie G and Wei-Hsien. 2005. "Comparative Analysis of Piezoelectric Power Harvesting Circuits for Rechargeable Batteries". Proceedings of the 2005 IEEE International Conference on Information Acquisition . China.
- [29] Shahab M, Jagannathan S & Keith C. 2008. "Energy Harvesting Using Piezoelectric Materials and High Voltage Scavenging Circuitry". IEEE.
- [30] Qiu JH, Ji HL & Shen H. "Energy Harvesting and Vibration Control Using Piezoelectric Elements and a Nonlinear Approach". China.
- [31] Tan YK, Lee JY & Panda SK. 2008. "Maximize Piezoelectric Energy Harvesting Using Synchronous Charge Extraction Technique for Powering Autonomus Wireless Transmitter". International Congress Society Engineering Technology 2008. 1123-1128.
- [32] Shad R, Eli SL, Jessy B, Eric C, Elizabeth R, Elaine L, Brian O, Jan MR, Paul KW & Sundararajan V. 2005. " Improving Power Output for Vibration-Based Energy Scavengers". IEEE Computer Society. 28-36.

- [33] Huidong Li, Chuan T & Deng ZD. 2014. "Energy Harvesting from Low Frequency Applications Using Piezoelectric Materials". *Journal of Applied Physics Reviews*. AIP Publishing. 1. 041301.DOI: 10.1063/1.4900845.