

HYDROGEN PRODUCTION FROM PHENOL STEAM REFORMING OVER Ni-Co/ZrO₂ CATALYST: EFFECT OF CATALYST DILUTION

Article history

Received
19 May 2015
Received in revised form
24 March 2016
Accepted
1 May 2016

Walid Nabgan^{a,b}, Tuan Amran Tuan Abdullah^{a,b*}, Ramli Mat^b, Bahador Nabgan^a, Umi Aisah Asli^{a,b}, Anwar Johari^b

*Corresponding author
tamran@cheme.utm.my

^aCentre of Hydrogen Energy, Institute of Future Energy, Universiti Teknologi Malaysia, 81310 UTM Johor Bahru, Johor, Malaysia

^bDepartment of Chemical Engineering, Faculty of Chemical and Energy Engineering, Universiti Teknologi Malaysia, 81310 UTM Johor Bahru, Johor, Malaysia

Graphical abstract

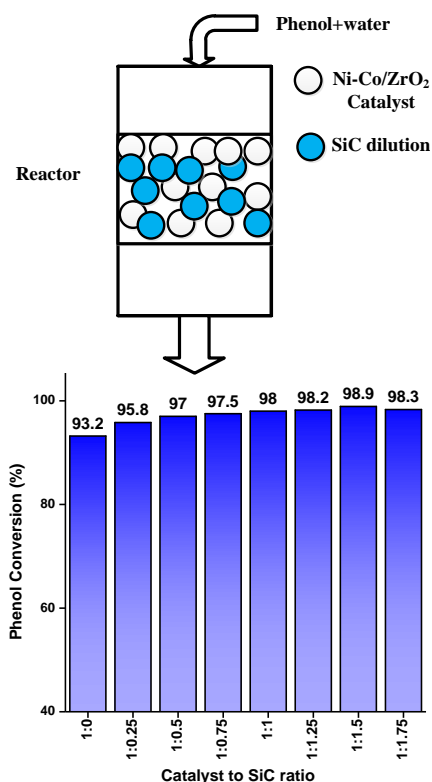

Abstract

This study looked into the hydrogen production from phenol steam reforming over Zirconia (ZrO₂)-supported nickel-cobalt catalysts diluted with silicon carbide (SiC). The objective of this study is to obtain the effect of catalyst dilution on hydrogen production and the phenol conversion in various SiC dilutions. The catalysts were prepared by impregnation method and their performance tests were carried out in a micro fixed bed reactor at atmospheric pressure and 800 °C temperature, feed flow rate 0.36 mL/min, weight of catalyst 0.2 g, and dilution range of 0.05 to 0.35 g (1:0 to 1:1.75). The results showed that the catalyst dilution does not affect much on the catalyst activity toward phenol conversion. However, it does improve the conversion of phenol with the presence of SiC. The maximum conversion was at 0.3 g (1:1.5) SiC dilution, which was of 98.9 % and 0.6 mole fraction of hydrogen.

Keywords: Phenol steam reforming; Ni-Co/ZrO₂; dilution; catalyst activity

Abstrak

Kajian ini adalah penghasilan hidrogen daripada pembentukan semula stim fenol menggunakan mangkin nikel-kobalt disokong dengan zirconia (ZrO₂) yang dijarang dengan silikon karbid (SiC). Objektif kajian ini adalah untuk menentukan kesan penjarangan mangkin dalam penghasilan hidrogen dan penukaran fenol dengan penjarangan SiC yang berbagai. Mangkin disediakan dengan kaedah impregnasi dan keupayaannya diuji dalam satu reaktor mikro terpadat pada tekanan atmosfera dan suhu pada 800 °C, kadar alir 0.36 mL/min, berat mangkin 0.2 g dan penjarangan dalam anggaran 0.05 hingga 0.35 g. Hasil kajian menunjukkan penjarangan mangkin memberi kesan yang tinggi terhadap aktiviti mangkin terhadap penukaran fenol dan tindakbalas shif gas stim. Tetapi, ia sememang meningkatkan penukaran fenol dengan kehadiran SiC. Nilai maksimum penukaran suapan dengan penjarangan 0.3 g SiC (1:1.5) adalah 98.9% dan 0.6 pecahan mol hidrogen terhasil.

Katakunci: Pembentukan semula fenol, Ni-Co/ZrO₂, penjarangan, aktiviti mangkin

1.0 INTRODUCTION

The clean burning nature and possible native production and high efficiency fuel cell vehicles potential cause the increasing interest in the usage of hydrogen to replace the energy business fossil fuel. It is a promising energy that potentially plays an important role in future energy systems and replacing fossil energy [1-3]. In order to extract hydrogen, energy must be spent. Bio-oil is a preferred hydrogen resource due of its renewability and environmental benefit characteristics [4, 5]. In the present study, only the main unwanted component of bio-oil, phenol (38 wt.% of bio-oil), is used as a source of hydrogen production due to its non-inflammable nature and its major problem as corrosive resistant materials for engine fuel is chosen [6-9].

Hydrogen can be obtained using several technologies such as steam reforming (SR) [8, 10], coal gasification [11], auto-thermal reforming (ATR) [12-14], dry reforming (DR) [6, 15], partial oxidation (POX) [12], thermolysis [16, 17] and electrolysis [18, 19]. Currently the dominant technology for the hydrogen production is hydrocarbons steam reforming and is an issue of great significance in refinery as well as clean fuel production and is a simple yet dominant technology for hydrogen production [20, 21]. Therefore steam reforming method for hydrogen production is selected in this. The bimetallic Ni-Co supported on ZrO₂ is used inside the reformer because Ni and noble-based catalysts are found to be more active and selective to hydrogen production and the bimetallic Ni-Co supported on ZrO₂ gives good hydrogen yields in phenol steam reforming [22]. For instance, cobalt-based catalyst is an appropriate catalyst for steam reforming of bio-oil due to its advantages of having no catalyst inventory cost and low temperature towards high hydrogen yield. Moreover, cobalt has the capability to promote C-C bond rupture at temperatures as low as 400 °C and supported cobalt catalysts have shown higher production to H₂ and CO₂ and lower production to ethylene [23]. Using ZrO₂ as the catalyst support, offers chemical and corrosion inertness to temperatures well above the melting point of alumina and the material has low thermal conductivity. It is also electrically conductive above 600 °C and is used in oxygen sensor cells and as the susceptor (heater) in high temperature induction furnaces [24]. In the steam reforming of phenol, phenol decomposition (1) and water gas shift reaction (2) are two major reactions [25]:

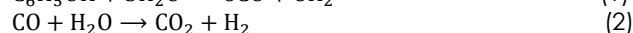
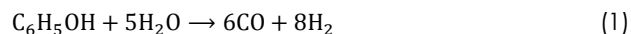

The concept of dilution of catalyst has been applied to exothermic reactions carried out in tubular reactors packed with catalyst. Here, the rate of heat generation varies remarkably along the length of the reactor, rising to undesirable temperature peaks. Due to this situation, it can be noted that a specific temperature profile can be established in a fixed bed

by means of catalyst dilution and in certain cases, this strategy can be employed to improve the reactor performance [26]. Glass, quartz, -alumina, and silicon carbide (SiC) can be the diluting agents because of their comparative solidity and their deserved heat transfer qualities are low-surface-area ingredients [27]. However, the catalyst dilution has the ability to increase the performance for complex successive reaction schemes over the undiluted catalyst [26]. In addition, dilution of the catalyst can significantly reduce the overall cost of the catalyst [28]. A viewpoint on the effect of catalyst dilution for bimetallic Ni-Co on ZrO₂ support for hydrogen production from the steam reforming of phenol has not yet been established. Therefore, the aim of this study is to evaluate the influence of catalyst dilution ratio on phenol conversion and hydrogen production.

2.0 EXPERIMENTAL

2.1 Catalyst Preparation

The catalysts was synthesized in-house by impregnation method. Impregnated catalyst was prepared by adding a support (ZrO₂) drop wise into the solution of active metal Ni-Co under continuous stirring at 90 °C until it became slurry. To prepare the catalyst, 10 wt.% active metal (5 wt.% Ni and 5 wt.% Co) with 90 wt.% support was used. Other than that, nickel and cobalt were obtained by using cobalt nitrate hexahydrate (Co (NO₃)₂.6H₂O) and Nickel nitrate hexahydrate (Ni (NO₃)₂.6H₂O). The amount of catalyst used of Co (NO₃)₂.6H₂O (X) and Ni (NO₃)₂.6H₂O (X) was calculated by using Equation (3).

$$X \text{ (g)} = 0.5 \text{ gram Ni(or)Co} \times \frac{1 \text{ mol Ni(or)Co}}{58.7 \text{ gr}} \times \frac{1 \text{ mol X}}{1 \text{ mol Ni(or)Co}} \times \frac{291 \text{ gr X}}{1 \text{ mol X}} \quad (3)$$

Based on the calculation, 0.5 g Ni, Co, 2.47 g Nickel nitrate hexahydrate or Cobalt nitrate hexahydrate was used. The slurry sample was dried in an oven at 110 °C overnight, followed by calcination in a furnace at 750 °C for 3 hours in the air subsequently. This temperature was high enough to decompose it [29], and then the sample was cooled down to room temperature in a desiccators. Figure 1 shows the steps and procedure of catalyst preparation.

2.2 Product Analysis

Prior to the experiment, the catalyst was reduced in-situ at 600 °C for an hour in the purified hydrogen of 30 cm³/min. At the reaction product exit of the reactor was cooled down at 10 °C in a graham glass condenser (Figure 2). Next, the condensate and the gas product were separated in a gas separator.

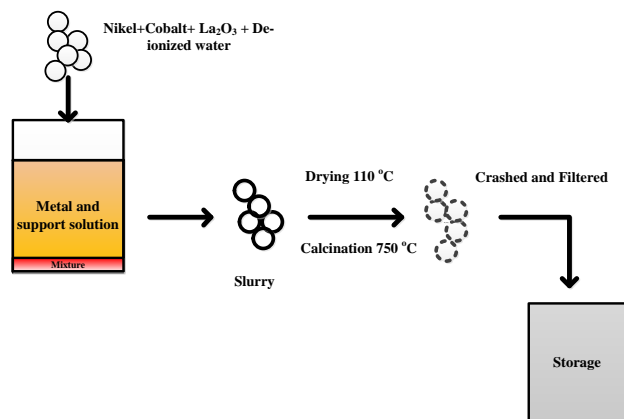

Figure 1 Catalyst preparation steps

After that, the gas was analysed by using an online GC-TCD (Agilent 6890N) equipped with a Carboxen Plot 1010 capillary column (Fused Silica, 30 m x 0.53 mm). The liquid was then collected once the gas was injected into the GC, and analysed using a GC-FID (HP5890 Series II) eluted in a CP-Wax 58 CB (Varian, 25 m x 0.32 mm) capillary column.

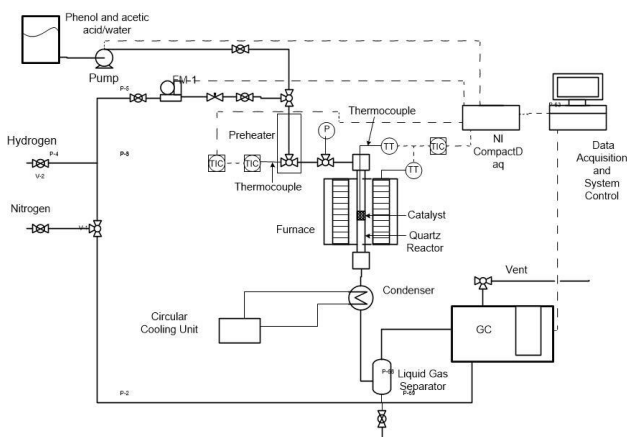

Figure 2 Schematic flow diagram of the experimental setup

The reaction product exit of the reactor was cooled at 10 °C in a graham glass condenser. Then, the condensate and the gas product were separated in a gas liquid separator. After that, the gas was analysed using an online GC-TCD (Agilent 6890N) equipped with a Carboxen Plot 1010 capillary column (Fused Silica, 30 m x 0.53 mm). The liquid was collected once the gas was injected into the GC, and analysed using a GC-FID (HP5890 Series II) eluted in a CP-Wax 58 CB (Varian, 25 m x 0.32 mm) capillary. Equations (3) and (4) were applied to compute the conversion and product mole fraction.

$$\text{Feed conversion (\%)} = \frac{[\text{feed}]_{\text{in}} - [\text{feed}]_{\text{out}}}{[\text{feed}]_{\text{in}}} \times 100\% \quad (3)$$

$$\text{Product mole fraction} = \frac{\text{mole of each component}}{\text{total moles of products}} \quad (4)$$

3.0 RESULTS AND DISCUSSION

3.1 Phenol Conversion

Figure 3 shows the effect of silicon carbide (SiC) catalyst dilution ratio on phenol conversion. The reaction was carried out in the temperature of 800 °C, the pressure was 1 atm and feed flow rate was set at 0.36 mL/min and the catalyst was 0.2 g. The ratio of the catalyst to SiC was describe as bellow (Table 1).

Table 1 Catalyst to SiC ratio

Catalyst (g)	SiC (g)	Ratio
0.2	0	1:0
	0.05	1:0.25
	0.10	1:0.50
	0.15	1:0.75
	0.20	1:1
	0.25	1:1.25
	0.30	1:1.50
	0.35	1:1.75

As it is shown in Figure 3, it can be noticed that the maximum conversion of phenol achieved at 0.3 g SiC which is 98.9 %, whereas the catalyst to SiC ratio of 1:0 has the lowest conversion (93.2 %). It is important to note that the ratio of SiC on the catalyst does not change much in the phenol conversion after 1:1 ratio. However higher dilution (0.35 g) can cause lower catalyst activity towards phenol conversion. Daniel et al. [30] was found that higher catalyst dilution can cause loss of conversion and lower activity of catalyst. In our previous research [31,32], we have found that the presence of silicon carbide in the diluted catalyst has a pronounced effect on the conversion of acetic acid to product gases due to the difference in catalyst bed height.

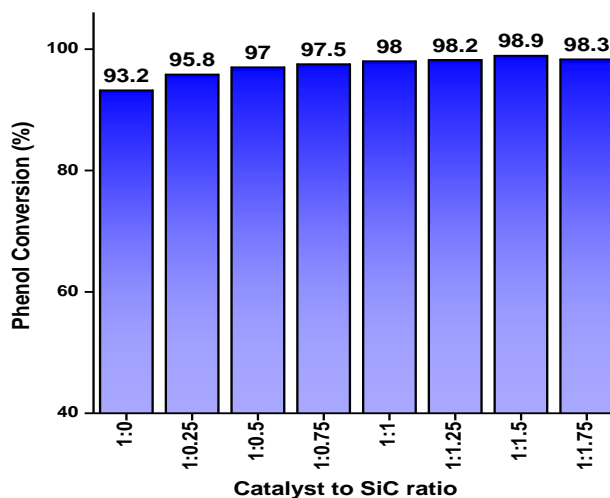

Figure 3 Effect of SiC loading on phenol conversion

3.2 Effect of SiC Loading on Gas Production

The product gas distribution (mole) for catalyst dilution loading is shown in Figure 4. The reaction was carried out in the temperature of 800 °C, the pressure was 1 atm and feed flow rate was set at 0.36 mL/min and the catalyst was 0.2 g. There are three major components detected in the product gas namely H₂, CO and CO₂. The H₂ mole fraction slightly increased from the catalyst to SiC ratio of 1:0 to 1:0.25. The hydrogen mole fraction decreased with increasing the amount of catalyst dilution until 0.2 g (1:1) then slightly increased at 0.25 g and 0.3 g. The increasing of CO₂ mole fraction from 0.23 at 0.15 g SiC to 0.26 at 0.3 g SiC dilution is due to the contribution of the water-gas shift reaction to the product.

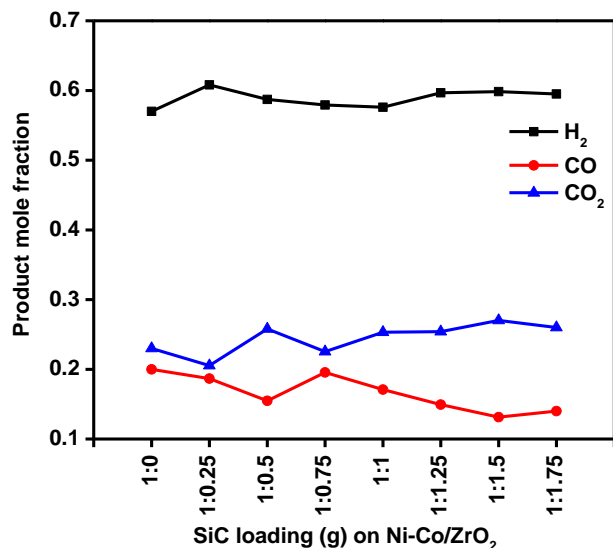

Figure 4 Effect of SiC loading on gas production

3.3 Effect of the Reaction Time on Product Distribution

Figure 5 shows the effect of reaction time on the bimetallic catalytic performance of the Ni-Co/ZrO₂ at reaction temperatures of 800 °C, 1 atm pressure, 0.36 mL/min flow rate and 0.2 g of catalyst for 40 to 280 minutes reaction. In dilution range of 0.05 (1:0.25) to 0.35 g (1:1.75), we can suggest that the good catalyst performance towards hydrogen production in the period of 40 to 240 minute was at 0.3 g SiC. It was found that, the hydrogen mole fraction decreased by increasing the time for catalyst to SiC ration of 1:0.25 and 1:0.5. It is possibly due to catalyst deactivation by coking formation. Therefore SiC can play an important role toward catalyst stability for long term use.

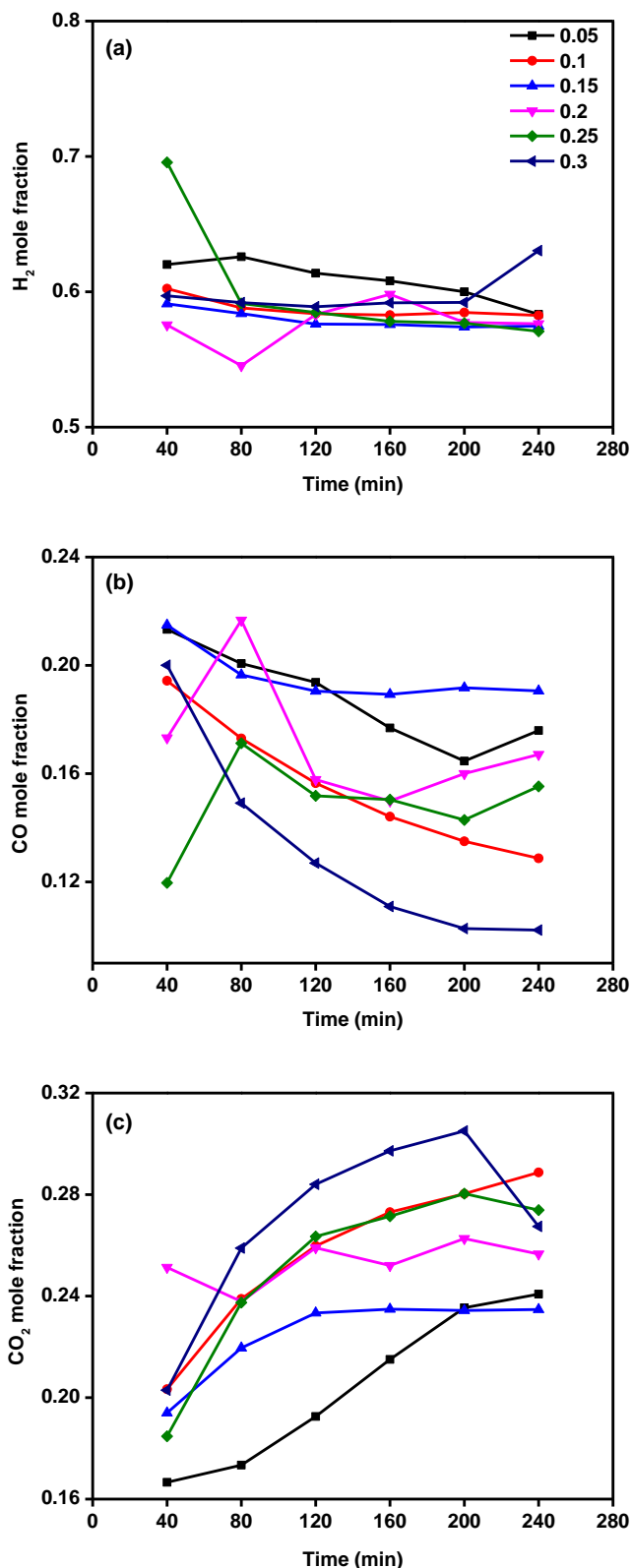

Figure 5 Effect of reaction time on product of (a) hydrogen, (b)CO and (c)CO₂ distribution

4.0 CONCLUSION

Steam reforming of phenol was performed in a fixed bed in the presence of diluted Ni-Co/ZrO₂ catalyst. The dilution loading was at the range of 0.05 to 0.35 g and catalyst was set at 0.2 g. This study shows that SiC increases the catalyst performance toward phenol conversion and stability for 240 minutes lab scale use. Base on the results obtained from liquid analysis, which is the phenol conversion, the highest conversion change was for diluted catalyst over undiluted catalyst. Changing the rate of Ni-Co/ZrO₂ towards SiC dilution does not affect to catalyst performance. It was found that the maximum feed conversion was on 0.3 g SiC dilution, referring to 98.9% and 0.6 mole fraction of hydrogen.

Acknowledgement

The authors express gratitude to the financial support given for this work by Universiti Teknologi Malaysia (UTM) under the Research University Grant GUP 08J70.

References

- [1] Chen, Y and X. Hengyong. 2006. Hydrogen Production from the Steam Reforming of Liquid Hydrocarbons in Membrane Reactor. *Catalysis Today*. 118(1–2): 136-143.
- [2] Jingbo, W. and G. Cheng. 2012. Hydrogen-rich Gas Production by Steam Gasification of Municipal Solid Waste (MSW) Using NiO Supported on Modified Dolomite. *International Journal of Hydrogen Energy*. 37: 6503 - 6510.
- [3] Walid, N., T.A.T. Abdullah, R. Mat, B. Nabgan, A.A. Jalil, L. Firmansyah, S. Triwahyono. 2016. Production of Hydrogen via Steam Reforming of Acetic Acid over Ni and Co Supported on La₂O₃ Catalyst. *International Journal of Hydrogen Energy*. [In Press] Available online 20 May 2016. <http://www.sciencedirect.com/science/article/pii/S036031991530865X>
- [4] Czernik, S., R. French, C. Feik, and E. Chornet. 2002. Production of Hydrogen by Co-reforming Biomass Pyrolysis Liquids and Natural Gas. *Fuel Chemistry Division Preprints*. 47(1): 373.
- [5] Xun, H. and G. Lu. 2010. Acetic Acid Steam Reforming to Hydrogen over Co–Ce/Al₂O₃ and Co–La/Al₂O₃ Catalysts—The Promotion Effect of Ce and La Addition. *Catalysis Communications*. 12(1): 50-53.
- [6] Jaimee, K. D. and A.W. Weimer. 2004. Dry Reforming of Methane Using a Solar-Thermal Aerosol Flow Reactor. *Industrial & Engineering Chemistry Research*. 43(18): 5489-5495.
- [7] Kazuhiro, T., K.i. Aika, K. Seshan, and L. Lefferts. 2004. Sustainable Hydrogen from Bio-oil—Steam Reforming of Acetic Acid as a Model Oxygenate. *Journal of Catalysis*. 227(1): 101-108.
- [8] Medrano, J.A., M. Oliva, J. Ruiz, L. Garcia, and J. Arauzo. 2008. Catalytic Steam Reforming of Acetic Acid in a Fluidized Bed Reactor with Oxygen Addition. *International Journal of Hydrogen Energy*. 33(16): 4387-4396.
- [9] Neiva, L.S. and L. Gama. 2010. A Study On The Characteristics Of The Reforming Of Methane: A Review. *Brazilian Journal of Petroleum and Gas*. 4(3): 119-127.
- [10] Esteban, A.S., and R.A. Comelli. 2014. Hydrogen Production by Glycerol Steam-reforming over Nickel and Nickel-cobalt Impregnated on Alumina. *International Journal of Hydrogen Energy*. 39(16): 8650-8655.
- [11] Babatunde, O., abd A. Kumar. 2013. Techno-economic Assessment of Hydrogen Production from Underground Coal Gasification (UCG) in Western Canada with Carbon Capture and Sequestration (CCS) for Upgrading Bitumen from Oil Sands. *Applied Energy*. 111: 428-440.
- [12] Sari, P. K., F. Al-Muhaish, A. Harale, and T.V. Pham. 2014. On-site Hydrogen Production from Transportation Fuels: An Overview and Techno-economic Assessment. *International Journal of Hydrogen Energy*. 39(9): 4331-4350.
- [13] Lihong, H., F. Zhang, N. Wang, R. Chen, and A.T. Hsu. 2012. Nickel-based Perovskite Catalysts with Iron-doping via Self-combustion for Hydrogen Production in Auto-thermal Reforming of Ethanol. *International Journal of Hydrogen Energy*. 37(2): 1272-1279.
- [14] Lihong, H., F. Zhang, R. Chen, and A.T. Hsu. 2012. Manganese-promoted Nickel/Alumina Catalysts for Hydrogen Production via Auto-thermal Reforming of Ethanol. *International Journal of Hydrogen Energy*. 37(21): 15908-15913.
- [15] Jianjun G., H. Lou, H. Zhao, D. Chai, and X. Zheng. 2004. Dry Reforming of Methane over Nickel Catalysts Supported on Magnesium Aluminate Spinels. *Applied Catalysis A: General*. 273(1–2): 75-82.
- [16] Hyun, T. H., A. Al-Kukhun, and A. Varma. 2012. High and Rapid Hydrogen Release from Thermolysis of Ammonia Borane Near PEM Fuel Cell Operating Temperatures: Effect of Quartz Wool. *International Journal of Hydrogen Energy*. 37(8): 6764-6770.
- [17] Hyun, T. Hwang, A. Al-Kukhun, and A. Varma. 2012. High and Rapid Hydrogen Release from Thermolysis of ammonia borane near PEM fuel cell operating Temperatures. *International Journal of Hydrogen Energy*. 37(3): 2407-2411.
- [18] Abudukeremu, K., Y. Simayi, K. Chandrasekhar, M. Ismail, and M.S. Kalil. 2015. Hydrogen Gas Production with an Electroformed Ni Mesh Cathode Catalysts in a Single-Chamber Microbial Electrolysis Cell (MEC). *International Journal of Hydrogen Energy*. 40(41): 14095-14103.
- [19] Alexander, T., P. Wasserscheid, M. Baldauf, and T. Hammer. 2015. Techno-economic Analysis for the Synthesis of Liquid and Gaseous Fuels Based on Hydrogen Production via Electrolysis. *International Journal of Hydrogen Energy*. 40(35): 11457-11464.
- [20] [20] Athanasios, N.F., D.I. Kondarides, and X.E. Verykios. 2002. Production of Hydrogen for Fuel Cells by Reformation of Biomass-derived Ethanol. *Catalysis Today*. 75(1–4): 145-155.
- [21] Bahador, N. 2014. Hydrogen Production From Acetic Acid-Phenol Steam Reforming Over Bimetallic Nickel-Cobalt Supported On Lanthanum Oxide-Gamma Aluminum Oxide Catalyst. *Universiti Teknologi Malaysia*.
- [22] Dmitri, A.B., and J.R.H. Ross. 2011. Catalysis for Conversion of Biomass to Fuels via Pyrolysis and Gasification: A Review. *Catalysis Today*. 171(1): 1-13.
- [23] [23] Jordi, L., N.s. Homs, J. Sales, and P. R. de la Piscina. 2002. Efficient Production of Hydrogen over Supported Cobalt Catalysts from Ethanol Steam Reforming. *Journal of Catalysis*. 209(2): 306-317.
- [24] Ralph, H. N., and G. Wilfing. 2000. *Zirconium and Zirconium Compounds*. *Ullmann's Encyclopedia of Industrial Chemistry*, Wiley-VCH Verlag GmbH & Co. KGaA.
- [25] Kyriaki, P., and A. Bakandritsos, V. Tzitzios, J.L.G. Fierro, A.M. Efstathiou. 2006. Absorption-enhanced Reforming of Phenol by Steam over Supported Fe Catalysts. *Journal of Catalysis*. 241(1): 132-148.
- [26] Irani, R.K., B.D. Kulkarni, and L.K. Doralswamy. 1979. Effect of Catalyst Dilution on the Performance of a Fluid Bed Reactor for Complex First-Order Resctions. *Industrial & Engineering Chemistry Process Design and Development*. 18(4): 648-652.
- [27] Rob, J. B., J. Pérez-Ramírez, F. Kapteijn, and J.A. Moulijn. 2002. Catalyst Performance Testing: Bed Dilution Revisited. *Chemical Engineering Science*. 57(22–23): 4921-4932.
- [28] Sungwon, H., and R. Smith. 2004. Heterogeneous Catalytic Reactor Design with Optimum Temperature Profile I:

- Application of Catalyst Dilution and Side-stream Distribution. *Chemical Engineering Science*. 59(20): 4229-4243.
- [29] Ienwhei, C., and D.W. Shiue. 1988. Reduction of nickel-alumina catalysts. *Industrial & Engineering Chemistry Research*. 27(3): 429-434.
- [30] Danišl, V.H., P. Castaño, M. Makkee, J.A. Moulijn, and M.T. Kreutzer. 2009. Catalyst Testing in a Multiple-parallel, Gas-liquid, Powder-packed Bed Microreactor. *Applied Catalysis A: General*. 365(2): 199-206.
- [31] Abdullah, T.A.T., W. Nabgan, M.J. Kamaruddin, R. Mat, A. Johari, and A. Ahmad. 2014. Hydrogen Production from Acetic Acid Steam Reforming over Bimetallic Ni-Co on La₂O₃ Catalyst- Effect of the Catalyst Dilution. *Applied Mechanics and Materials*. 493: 39-44
- [32] Nabgan, W., T. A. T. Abdullah, R. Mat, B. Nabgan, Y. Gambo and K. Moghadamian. 2016. Acetic Acid-phenol Steam Reforming for Hydrogen Production: Effect of Different Composition of La₂O₃-Al₂O₃ Support for Bimetallic Ni-Co Catalyst. *Journal of Environmental Chemical Engineering*. 4(3): 2765-2773.