

## REDUCING SOAK AIR TEMPERATURE INSIDE A CAR COMPARTMENT USING VENTILATION FANS

Haslinda Mohamed Kamar\*, Nazri Kamsah, Intan Sabariah Sabri, Md Nor Musa

Faculty of Mechanical Engineering, Universiti Teknologi Malaysia, 81310 UTM Johor Bahru, Johor, Malaysia.

**Article history**  
Received  
1 January 2016  
Received in revised form  
18 May 2016  
Accepted  
15 June 2016

\*Corresponding author  
haslinda@mail.fkm.utm.my

### Graphical Abstract

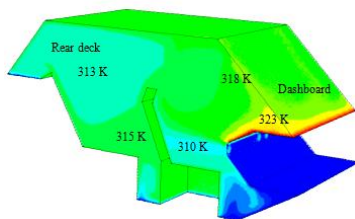

### Abstract

This article presents an investigation on the effects of using ventilation fans on the air temperature inside a car passenger compartment when the car is parked under the sun. It was found from a measurement that the air temperature inside the passenger compartment could raise up to 48°C. Computational fluid dynamics method was used to develop model of the compartment and carry out flow simulations to predict the air temperature distribution at 1 pm for two conditions: without ventilation fans and with ventilation fans. The effects of fan location, number of fans used and fan airflow velocity were examined. Results of flow simulations show that a 17% temperature reduction was achieved when two ventilation fans with airflow velocity of 2.84 m/s were placed at the rear deck. When three fans were used, an additional 3.4% temperature reduction was attained. Placing two ventilation fans at the middle of the roof also reduced the air temperature by 17%. When four fans were used a further 4.8% temperature reduction was achieved. Increasing the airflow velocity at the four fans placed at the roof, from 2.84 m/s to 15.67 m/s, caused only a small reduction in the air temperature inside the passenger compartment.

**Keywords:** Soak air temperature; car passenger compartment; CFD simulation; mechanical ventilation system

### Abstrak

Artikel ini membentangkan hasil kajian kesan menggunakan kipas pengudaraan terhadap suhu udara di dalam ruang penumpang kereta apabila kereta tersebut diletakkan di bawah sinaran matahari. Hasil pengukuran menunjukkan bahawa suhu udara di dalam ruang penumpang boleh meningkat sehingga 48°C. Kaedah bendalir dinamik pengkomputeran telah digunakan untuk membangunkan model bagi ruang penumpang dan melakukan simulasi aliran untuk meramal taburan suhu udara pada jam 1 tengahari untuk dua keadaan: tanpa kipas pengudaraan dan dengan menggunakan kipas pengudaraan. Kesan kedudukan kipas, bilangan kipas dan halaju aliran udara kipas turut dikaji. Keputusan simulasi aliran menunjukkan bahawa penurunan suhu sebanyak 17% boleh dicapai apabila dua kipas pengudaraan dengan halaju aliran 2.84 m/s diletakkan pada bahagian dek belakang. Apabila tiga kipas digunakan, tambahan 3.4% penurunan suhu diperolehi. Meletakkan dua kipas pengudaraan di bahagian tengah bumbung juga mengurangkan suhu udara sebanyak 17%. Apabila empat kipas ditempatkan di atas bumbung, tambahan 4.8% penurunan suhu diperolehi. Meningkatkan halaju aliran udara pada empat kipas yang dipasang di bumbung, dari 2.84 m/s kepada 15.67 m/s hanya menghasilkan penurunan suhu yang kecil.

**Kata kunci:** Suhu udara jemuran; ruang penumpang kereta; simulasi CFD; sistem pengudaraan mekanikal

© 2016 Penerbit UTM Press. All rights reserved

## 1.0 INTRODUCTION

Air-conditioning (AC) system is the major auxiliary load for a light-weight vehicle [1]. It is designed to meet its peak cooling load to sufficiently reduce the air temperature inside the passenger compartment to a comfortable level after a 'hot soak'. The passenger compartment experiences the hot soak state when the vehicle is parked in the open under the sun. According to [2], during the peak cooling load condition the AC system extracts approximately 6 kW of power from the vehicle's engine. This is equivalent to a vehicle being driven down the road at 56 km/hr. Reducing the peak cooling load will lower the required cooling capacity [1] which indirectly will reduce the power consumption of the AC system. As the system is directly driven by the vehicle's engine, a reduction in its power consumption could lead to a reduction in the vehicle's fuel consumption [3]. One way for reducing the peak cooling load is to reduce the soak temperature inside the passenger compartment. For every 1°C reduction in the soak air temperature, there is a potential saving of 4.1% in AC system power consumption [4]. A mechanical ventilator has been identified as an efficient method for reducing the soak temperature inside the passenger compartment [5, 6].

Several works have been reported on the use of ventilation for reducing the soak temperature inside the passenger compartment. Saidur et al. [7] investigated experimentally the effect of using mechanical ventilator on soak temperature inside a passenger compartment. They found that, by increasing the air flow rate at the mechanical ventilator, they were able to reduce the soak temperature inside the passenger compartment effectively. Bharathan et al. [8] found that natural ventilation was able to reduce the soak temperature inside a passenger compartment during parking. Their study concluded that the use of natural ventilation method can be as effective as using forced ventilation (HVAC fans), provided that the inlet air vent is located at a suitable place. One possible location for the inlet air vent is at the foot level. However, this could cause infiltration of moisture and air contaminants into the compartment, which are undesirable. Rugh et al. [9] studied the combined effect of using mechanical ventilator, solar-reflective glazing and solar-reflective paint on air temperature inside a passenger compartment. They reported that the breath air temperature, seat temperature, windscreen temperature and the instrument panel surface temperature were reduced by about 12°C, 11°C, 20°C and 17°C, respectively. Huang et al. [10] used a 3-D computational fluid dynamics (CFD) simulation to study the effect of utilizing automatic ventilation system during idling on air temperature inside a passenger compartment. The ventilation system will automatically turned 'on' when the air temperature inside the compartment exceeds the pre-set temperature value and turned 'off' when it is

below the pre-set value. They found that this strategy was able to reduce the air temperature inside the passenger compartment as lower as the outside air temperature. Dadour et al. [11] developed a statistical model to predict the compartment air temperature variations in a parked vehicle using environmental temperature and radiation data as input. They showed that the compartment air temperature can be reduced by 3°C when the driver's window of the vehicle was lowered by 2.5 cm (natural ventilation mode). In a study done by Jasni and Nasir [12] (2012), the usage of solar-powered air ventilator was found capable of reducing the average air temperature inside the car compartment by as much as 3°C.

This paper presents a study on the effects of using mechanical ventilator fans on the soak air temperature inside a passenger car compartment using computational fluid dynamic (CFD) technique. The goal is to assess the effectiveness of the mechanical ventilator fans in reducing the soak air temperature inside the passenger compartment. A field measurement was conducted to acquire surface temperatures at various sections of the car envelope and the air temperature at two locations inside the passenger compartment. A CFD simulation model was developed using Fluent 6.3 software. The model was validated by comparing the air temperatures at the two locations obtained from the field measurement with the values predicted by the CFD simulation. The validated CFD model was then used to predict temperature distribution inside the passenger compartment and estimate the average air temperature value. The effects of fans placement, number of fans used and outlet air velocity on the average air temperature inside the car compartment were also examined.

## 2.0 METHODOLOGY

In this study, ANSYS Fluent CFD software was used to develop the model of the actual vehicle and carry out the flow simulations, employing the RANS approach, in particular using the k- $\epsilon$  turbulent model. Since the RANS approach generally uses many approximations, it is necessary to validate the CFD model against the real model. For this validation purposes, accurate experimental data of the air temperature inside the passenger compartment is necessary for comparison. Actual temperatures of the various sections of the car envelope are also needed for the boundary conditions of the CFD model. Since these values are not available in any literatures, the authors performed their own field measurement on the actual vehicle that was parked in open area and directly exposed to the sun. However, for validation purposes, the vehicle was not equipped with any ventilation fans. Since the engine was not running, the air inside the passenger compartment was considered as stagnant. Movement of the air inside the passenger

compartment was assumed laminar and heat transfer process was assumed as by natural convection only. Therefore, for the validation of the CFD model, a laminar flow solver was used in the simulation.

### 2.1 Field Measurement for CFD Validation

A field measurement was conducted on an actual Proton Saga BLM car which has a metallic white body colour. The car was parked in an open area and facing the sunrise direction so that the frontal section of the car was directly exposed to the sunlight as the sun rises. The field measurement was conducted with two objectives. The first was to acquire surface temperatures at selected points on several sections of the car envelope. These temperatures will be used to estimate the average temperature on each section. These average temperatures will be used as the boundary conditions for the CFD simulations. The second objective was to estimate the temperature of the air inside the passenger compartment, at the front and rear sections. These temperatures will be used for validating the CFD simulation model. The field measurement was repeated for three days in succession and at the same time to ensure the consistency of the acquired data. During the field measurements, there were no occupants in the passenger compartment and the engine of the car was not running.

A total of twelve type-T thermocouples with an accuracy of  $\pm 1^\circ\text{C}$  were used to measure the temperatures at designated points on the seats, dashboard, roof, front windscreen and rear windscreen. These points are shown schematically in Figure 1. All thermocouples were connected to a data acquisition system as shown in Figure 2(b). Additional two type-T thermocouples were used to measure the air temperature inside the passenger compartment, one at the front and the other at the rear section, at a distance of 280 mm from the roof as shown in Figure 2(c). This is approximately the head level of the passengers [11, 13, 14, 15]. The data acquisition system consists of a standard laptop computer furnished with PicoLog software and TC-08 USB data logger having an accuracy of  $\pm 0.5^\circ\text{C}$ , as illustrated in Figure 2(d). All thermocouples were calibrated by comparing their readings against those of a standard thermometer having an accuracy of  $\pm 0.1^\circ\text{C}$ , in a simple water heating experiment.

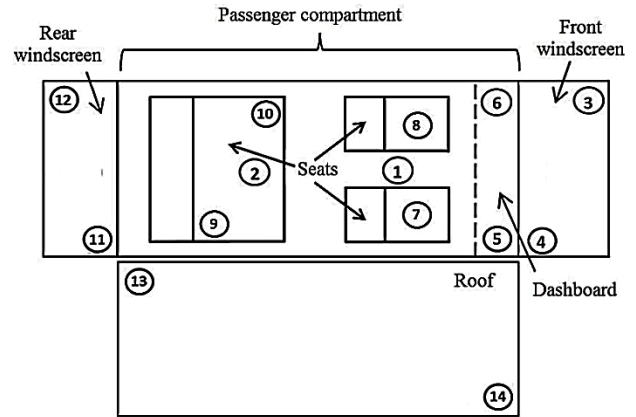

**Figure 1** Locations of temperature measurement points on various sections of the car body



**Figure 2** (a) The Proton Saga car, (b) The data acquisition system, (c) Additional thermocouples to measure air temperature at the front and rear section of the passenger compartment, (d) The TC-08 USB data logger

During the field measurements, temperatures were continuously recorded from 11 am to 3 pm, every 15 minutes time intervals. Using the recorded steady-state temperature data at 12 pm, 1 pm, 2 pm and 3 pm, the average temperatures of the seats, dashboard, roof, front windscreen and rear windscreen sections of the car were determined. The average temperatures of these sections as obtained from the field measurement are shown in Table 1. The local ambient air temperature at these hours was observed to be around  $36^\circ\text{C}$ . The incidence solar radiation was estimated to be about  $1 \text{ kW/m}^2$  [16].

**Table 1** Average temperature of various sections of the car envelop

Location	Average temperature (K)			
	12 pm	1 pm	2 pm	3 pm
Front windscreen	317.9	321.5	325.5	322.5
Rear windscreen	314.7	317.4	321.8	321.2
Roof	316.8	320.8	323.8	320.8
Dashboard	332.0	337.7	345.3	339.5
Front seats	319.1	319.1	319.1	319.1
Rear seat	318.4	318.4	318.4	318.4
Bottom	300	300	300	300

## 2.2 Field Measurement for CFD Validation

A simplified three-dimensional model of the passenger compartment of the Proton Saga car was constructed in Fluent 6.3 CFD software based on the actual dimensions. The length, width and height of the passenger compartment are 2523 mm, 1080 mm and 1240 mm, respectively, as shown in Figure 3. The CFD computational domain is bounded by the roof section, floor section, the side windows, the door panels, the front windscreen and the rear windscreen. The two front seats, the rear seat, the dashboard and the rear deck were incorporated into the CFD model. The width of a gap between the two front seats is 320 mm. The steering wheel and the clapboard between front seats were not included into the CFD model for simplification. Also, all curved surfaces were treated as flat surfaces. The side windows and door panels were constructed in vertical orientation so that we could assume that no radiation incidence will fall on these surfaces. The windows and door panels were all treated as solid walls. Four circular holes, each has diameter of 6 cm, were constructed on a vertical side of the dashboard facing the front seats. These holes represent the inlet vents for the cool air of the actual car.

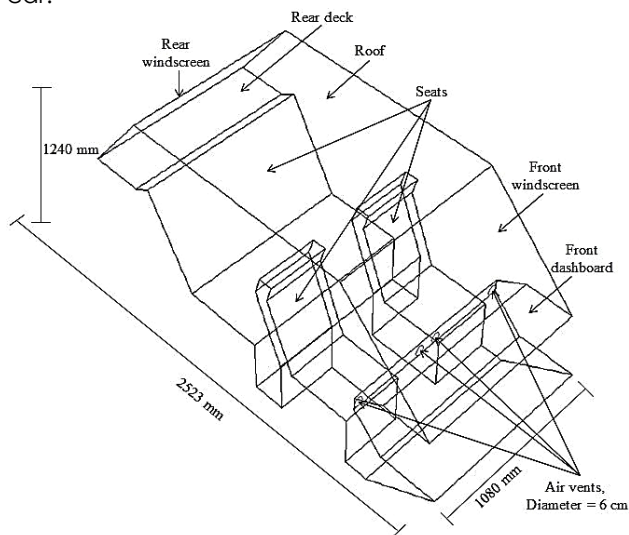
**Figure 3** A simplified CFD model of the car passenger compartment

The CFD computational domain was meshed using tetrahedral elements [16, 17] as shown in Figure 4. A volume meshing option with a skewness of 0.6 was chosen to enable automatic meshing process of the computational domain.

To perform the CFD simulations, we used temperatures as the boundary conditions instead of heat flux. The temperatures were prescribed on the various sections of the car envelope as shown in Figure 5. These temperatures represent the average temperature values obtained from the field measurement at the time of 1 pm. This time was chosen because the solar incidence intensity was at its maximum value [7]. Therefore we assumed that the temperatures at this time are the highest values attained by the car envelope.

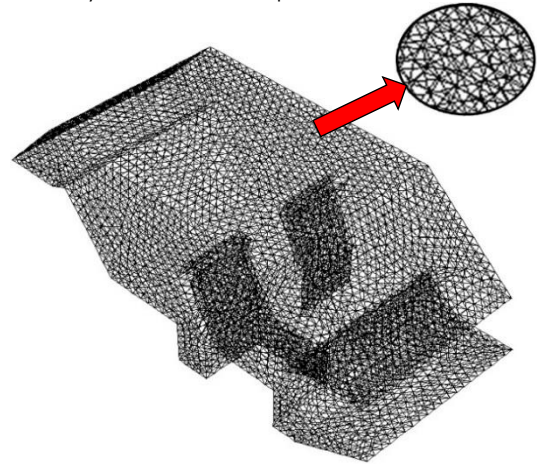
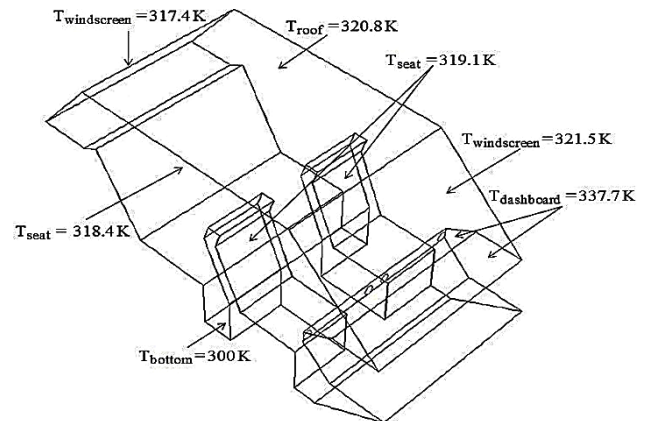
**Figure 4** The meshing of the CFD computational domain**Figure 5** The boundary conditions prescribed on the CFD model, based on highest temperatures obtained from the field measurement, at 1 pm

A laminar flow analysis was used in the CFD simulation since the movement of the air inside the passenger compartment was only due to density gradient resulting from temperature variation [7]. The effects of thermal radiation was neglected to simplify the CFD analysis. A pressure-based approach with segregated algorithm was chosen for solving the governing equations involving natural convection

phenomenon. The solution procedure for handling the coupling between pressure and velocity was based on a Semi-Implicit Method for Pressure-Linked Equations (SIMPLE) algorithm. A no-slip boundary condition was specified on the surfaces of the seats, front dashboard, rear deck, roof, front and rear windscreens, side panels, windows and bottom section. This refers to a condition of zero relative velocity of the air along these solid walls. The thermo-physical properties of the air inside the passenger compartment were assumed constant [16, 18, 19]. Convection condition was applied on the surfaces of the windows, front and rear windscreens and the roof, with a constant convective heat transfer coefficient of  $15 \text{ W/m}^2 \text{ }^\circ\text{C}$ . The thickness of all the glass sections was specified as 5 mm while the roof, which was assumed as opaque wall, is 12 mm thick [17, 20]. The convection term of the governing equation was solved by using the second-order upwind difference method [16, 17, 21]. The CFD simulations were performed under a steady-state condition in which a residual criterion for temperature was specified at  $10^{-4}$  and for energy was at  $10^{-6}$ .

**2.2.1 Mesh Sensitivity Test**

A mesh sensitivity test was carried out on the CFD model to ensure that the meshing has negligible effects on the results of the analysis. First a CFD analysis was carried out on the model that was meshed with certain number of coarser elements. Temperature of the air at the front section of the passenger compartment was chosen as the monitored parameter. The CFD simulation was repeated for several times, each with increasingly larger number of elements (more refined meshing). The air temperatures obtained from these CFD simulations were plotted against the number of elements used in the model. The plot is shown in Figure 6. Clearly, the air temperature obtained from the simulation was significantly affected by the number of elements used in the meshing of the CFD model. It is seen that when the number of elements used were 955,437 and higher, the number of elements has negligible effects on the air temperature. Therefore, in our CFD model a meshing with a total number of elements of 955,437 was adopted for all the proceeding simulations.

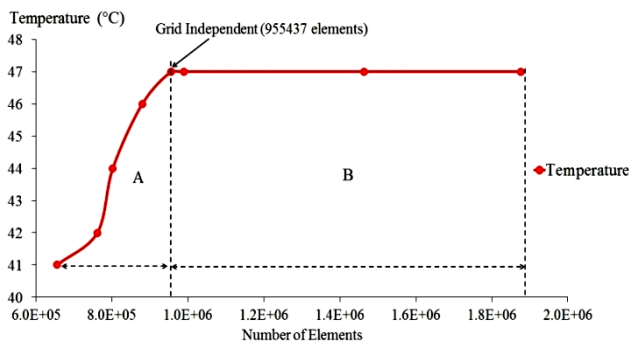

**Figure 6** Plot of air temperature vs. the number of elements for mesh sensitivity analysis

**2.2.2 Results of CFD Model Validation**

We carried out the validation of our CFD model by comparing the air temperature inside the passenger compartment, at both the front and rear section, obtained from the CFD analysis with the corresponding values obtained from the field measurement. The temperature values from the field measurement were obtained from 12 pm to 3 pm and when the car was not furnished with ventilation fans. The comparison of these temperatures is shown in Figure 7. It can be seen that the measured air temperature appears to increase quite steadily from 12 pm to 2 pm. This is due to a greenhouse effect that can be explained as follows. Thermal energy from the sun enters the car passenger compartment through the windscreens and windows. Some of this energy is absorbed by the seats, the dashboard and the floor. When these objects release the energy back, not all of them were transferred out of the compartment. Some of the released energy is reflected back since the energy released by these objects is at longer wavelengths than the sun thermal energy being transmitted in. This results in a gradual increase in the temperature of the seats, the dashboard and the air inside the passenger compartment. The measured air temperature falls slightly from 2 pm to 3 pm. This could be due to reduction in the intensity of the sun thermal radiation that falls on the car envelop during this period.

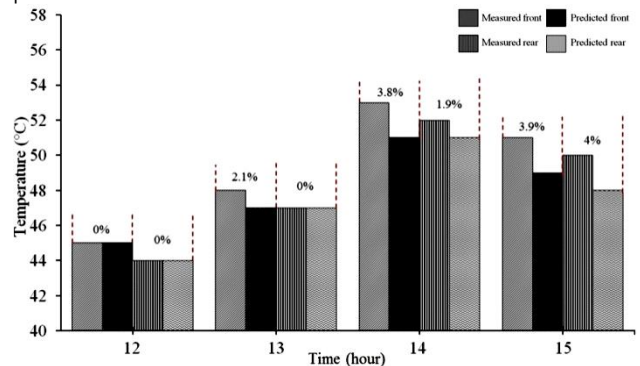

**Figure 7** Comparison between predicted and measured air temperature at the front and rear sections of the passenger compartment

We can also observe from the figure that the measured air temperature at the frontal section of the passenger compartment is always higher than that at the rear section, except at 12 pm where the measured and predicted air temperatures are nearly the same, at both the front and rear sections of the compartment. On average, the difference between the measured and predicted air temperatures at the frontal section is about 3.3%, which is acceptable. The predicted air temperatures at the rear section of the passenger compartment are similar with the measured values, at both 12 pm and 1 pm. However, the predicted temperatures are lower than the measured values, at both 2 pm and 3 pm. On

average, the difference between the predicted and measured average temperature values is about 3%. Based on the above finding, in our opinion the simplified CFD model of the car passenger compartment we developed in this study is validated, thus can be used in our proceeding analyses. In the case when the car is not being furnished with any ventilation fans, the uncertainty of our results is around 3%.

Figure 8 (a) shows the contour of air temperature distribution inside the passenger compartment at steady-state condition when the car is not furnished with ventilation fan. This result is based on the temperature boundary conditions prescribed on the model at the time of 1 pm. Figure 8 (b) shows the temperature contour on a vertical symmetrical plane that passes in between the front seats. The locations of the two thermocouples used to measure the air temperature at the front and rear sections of the compartment are shown.

As seen from Figure 8, the air closed to the dashboard surface is at the highest temperature of 333 K (60°C). Away from the dashboard, the temperature is seen to fall to 323 K (50°C). Below the dashboard and close to the rear deck the air temperature varies from 303 K (30°C) to 310 (37°C). The air closed to the roof and the front windscreen is seen at 320 K (47°C). A large section of the air inside the compartment is seen at a temperature of 318 K (45°C). The two thermocouples used to measure the air temperature in the front and rear section of the compartment give similar temperature readings of 318 K (45°C). It was found that the average temperature of the air inside the passenger compartment when no ventilation fans were used is about 321 K (48°C).

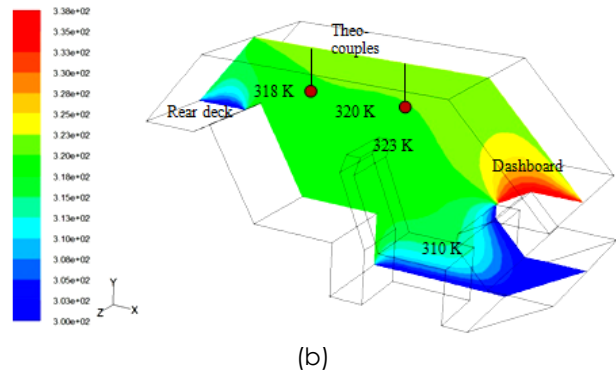

**Figure 8** Contour of air temperature (K) inside the car passenger compartment based on temperature boundary conditions at 1 pm: (a) an isometric view, (b) on a symmetrical plane of the CFD model

**2.3 Effects of Using Ventilation Fans**

We carried out CFD simulations to investigate the effects of using ventilation fans on the soak air temperature inside the passenger compartment when the car is parked directly under the sun. We assume that the fans are running continuously during the entire period when the car is parked. The ventilation fans will promote a flow of air inside the compartment. The air is induced from the inlet air vents on the front of the dashboard and delivered out from the compartment by the fans. We extend the CFD analysis by examining the effects of position of the ventilation fans, the number of fans used and the magnitude of the air velocity at the fans on the temperature of the air. The five different cases that we considered are summarized in Table 2.

**Table 2** Summary of the parametric study

Case	Fan Position	Number of fans	Air velocity at the fans, V (m/s)
1	Rear deck	3	2.84
2	Roof	2	2.84
3	Roof	4	2.84
4	Roof	4	15.67

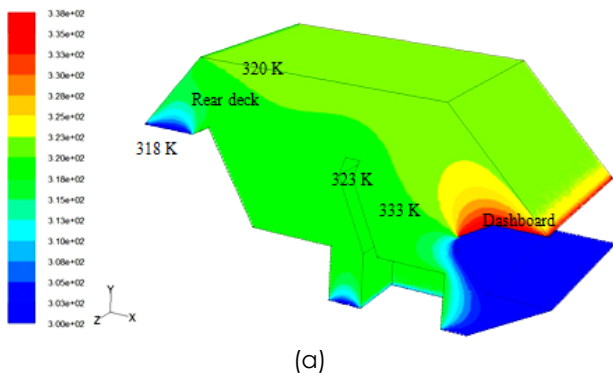

In case 1 two ventilation fans were placed at the rear deck of the passenger compartment. The fans were placed at a distance of 270 mm from the edges of the deck. Exterior air was assumed to enter the passenger compartment through the air inlet vents on the front side of the dashboard. This influx of air is promoted by the air movement caused by the ventilation fans. In case 2, three ventilation fans were placed at the rear deck of the passenger compartment. They were placed in a straight line arrangement, 270 mm from one another. In case 3, two ventilation fans were placed on the roof in a straight line arrangement along the symmetrical line, 540 mm away from the edges. In case 4, four ventilation fans were placed at the roof each directly

above the seats, 190 mm from the roof edges. These are illustrated schematically in Figure 9 through Figure 12. Case 5 is similar to case 4 in terms of number of ventilation fans used and their location. However, the outlet air velocity was increased from 2.84 m/s (or 20 cfm) to 15.67 m/s (or 110.5 cfm) based on the work of Saidur et al. [7]. This is to examine the effects of magnitude of air velocity at the ventilation fans on the air temperature inside the passenger compartment.

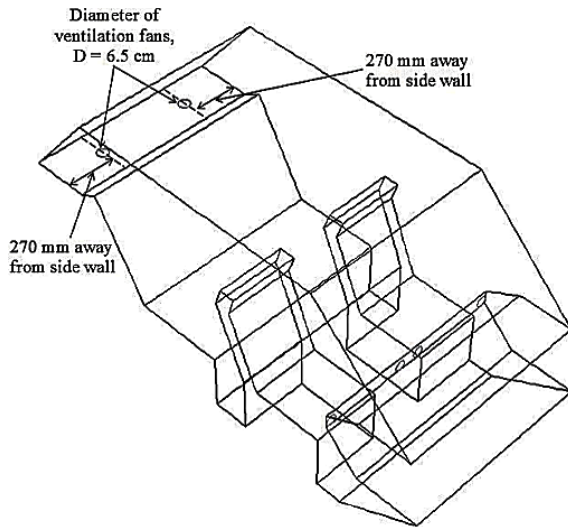

Figure 9 Two ventilation fans at rear deck

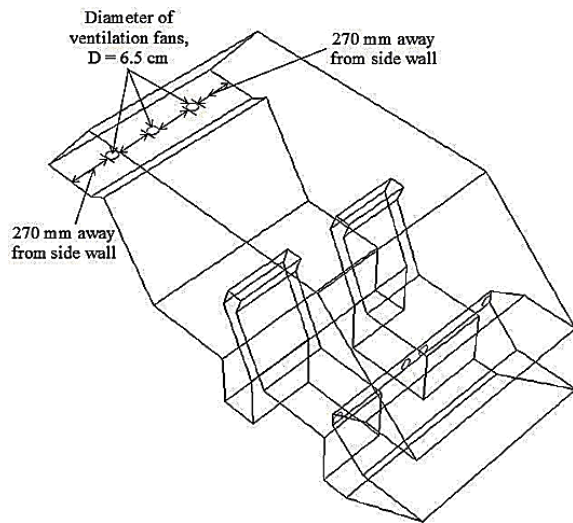

Figure 10 Three ventilation fans at rear deck

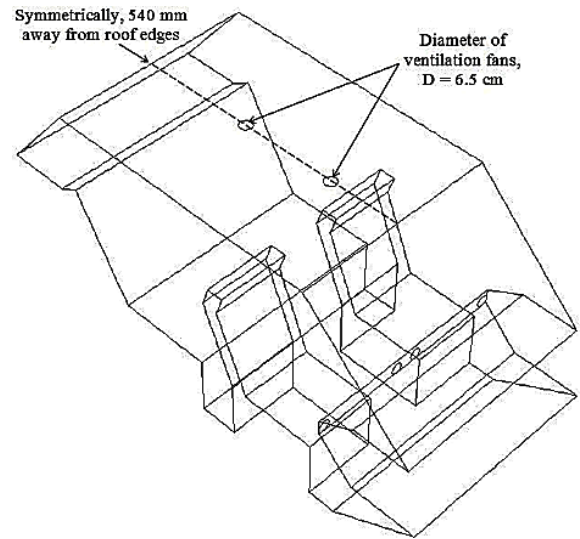

Figure 11 Two ventilation fans on the roofs

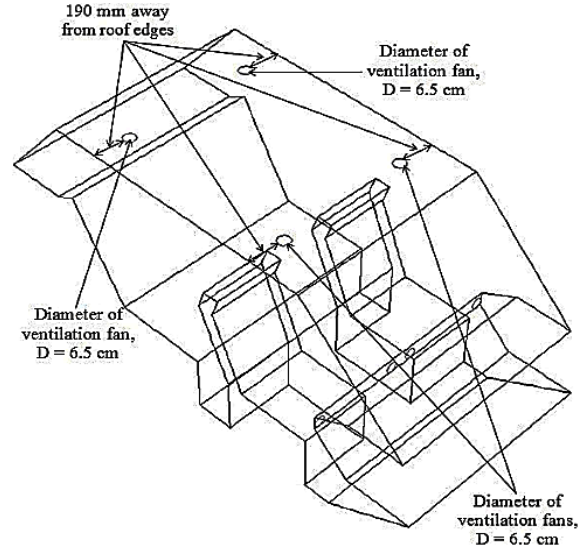
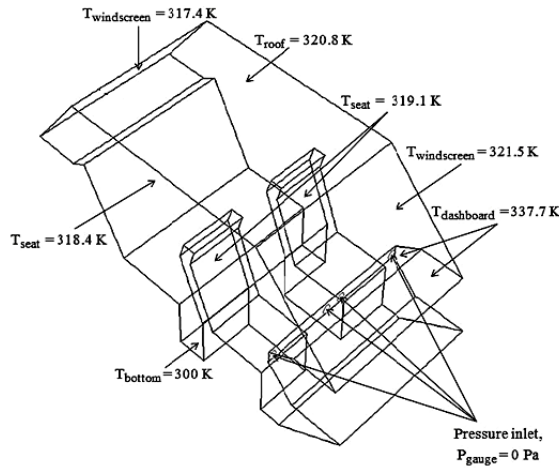

Figure 12 Four ventilation fans at the roof

### 2.3.1 Computational Procedure

For the CFD simulations with ventilation fans, the model was meshed using tetrahedral elements [16, 17] with a total of 955,437 elements. Volume mesh with a skewness of 0.6 was used. Temperature boundary conditions similar to those used in the validation model were employed, as illustrated in Figure 13.



**Figure 13** The temperature, air flow and pressure boundary conditions prescribed on the CFD computational domain for turbulent flow analysis

A no-slip condition was applied to all the walls that form envelop of the passenger compartment. The ventilation fans were modelled as a circular hole having a diameter of 6.5 cm [7]. To simulate the air flow condition inside the computational domain, two additional boundary conditions were specified. These are outlet air velocity at the ventilation fan and a zero gage pressure at the inlet air vents on the front face of the dashboard. The air flow vector was applied in the direction normal to the holes representing the ventilation fans. The magnitude of the air flow velocity at the ventilation fan for case 1 to case 5 was specified as 2.84 m/s (or 20 cfm). For case 6, the air flow velocity at the ventilation fans was set at 15.67 m/s, based on the work of Saidur et al. [7]. The temperature of the air at the inlets was set at 309 K (36°C).

Turbulent flow analysis was chosen for the CFD simulations with ventilation fans. The two equations standard  $k-\epsilon$  turbulence model was used. This flow model is known to be robust and widely used by many for flow analyses [22]. The standard  $k-\epsilon$  turbulence model is a semi-empirical model based on transport equations for the turbulence kinetic energy ( $k$ ) and turbulence dissipation rate ( $\epsilon$ ). The transport equation model for kinetic energy was derived from the exact equation, while the transport equation model for dissipation energy was obtained using physical reasoning. The flow was assumed as fully turbulent in the derivation of  $k-\epsilon$  model. A turbulent intensity of 10% was prescribed at the air inlet vents [16, 17] and turbulent viscosity ratio was also set at 10%. The turbulent kinetic energy and turbulent dissipation rate was prescribed as  $1 \text{ m}^2/\text{s}^2$ . A standard wall function was used in the turbulent flow CFD simulations.

$$\frac{\partial}{\partial t}(\rho k) + \frac{\partial}{\partial x_i}(\rho k u_i) = \frac{\partial}{\partial x_j} \left[ \left( \mu + \frac{\mu_t}{\sigma_k} \right) \frac{\partial k}{\partial x_j} \right] + G_k + G_b - \rho \epsilon + S_k$$

$$\text{and} \tag{3.1}$$

$$\frac{\partial}{\partial t}(\rho \epsilon) + \frac{\partial}{\partial x_i}(\rho \epsilon u_i) = \frac{\partial}{\partial x_j} \left[ \left( \mu + \frac{\mu_t}{\sigma_\epsilon} \right) \frac{\partial \epsilon}{\partial x_j} \right] + C_{1\epsilon} \frac{\epsilon}{k} (G_k + C_{3\epsilon} G_b) - C_{2\epsilon} \rho \frac{\epsilon^2}{k} + S_\epsilon \tag{3.2}$$

where  $G_k$  represents the generation of turbulence kinetic energy due to the mean velocity gradients while  $G_b$  represents the generation of turbulence kinetic energy due to buoyancy. The  $C_{1\epsilon}$ ,  $C_{2\epsilon}$ , and  $C_{3\epsilon}$  are constants whereas  $\sigma_k$  and  $\sigma_\epsilon$  are the turbulent Prandtl numbers for  $k$  and  $\epsilon$ , respectively.  $S_k$  and  $S_\epsilon$  are the user-defined. Default values of the constants  $C$  were used as follows:  $C_{1\epsilon} = 1.44$ ,  $C_{2\epsilon} = 1.92$  and  $C_{3\epsilon} = 0.09$ .

### 3.0 RESULTS AND DISCUSSION

The distribution of air temperature inside the passenger compartment when two ventilation fans were placed at the rear deck is shown in Figure 14. It is seen that the air in the rear section of the compartment is mostly at a temperature of 313 K (40°C). The air temperature in the front section is varies from 310 K (37°C) in front of the dashboard to 315 K (42°C) close to the headrest of the front seats and to 318 K (45°C) close to the windscreen. The air close to the dashboard is at 323 K (50°C). Figure (b) shows the distribution of air temperature on a vertical symmetrical plane of the passenger compartment. We can clearly observe that the region of air with temperature of 313 K (40°C) extends from the rear deck up to the front of the dashboard and close to the floor. In frontal upper region the air is mostly at a temperature of 315 K (42°C). The air under the dashboard has the lowest temperature of about 308 K (35°C). We found that the average air temperature inside the passenger compartment is about 313 K (40°C). This result shows that when two ventilation fans were placed at the rear deck, the average air temperature could potentially be reduced by 8.3°C compared with when no ventilation fans were used. This represents about 17.4 % temperature reduction which can be considered quite significant.

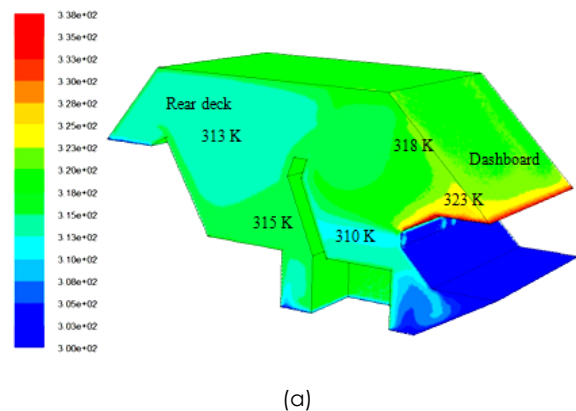



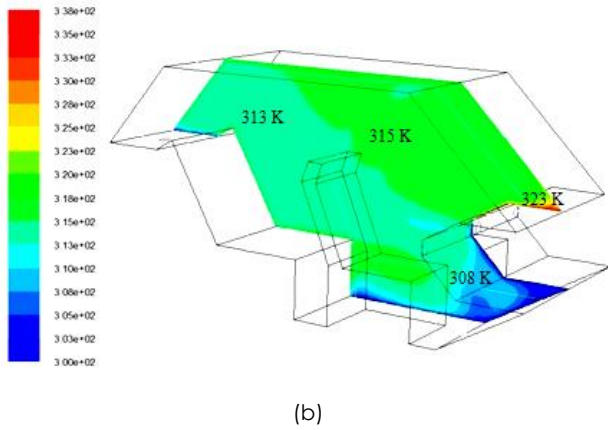

**Figure 14** Distribution of air temperature inside the car compartment when two ventilation fans were placed at the rear deck: (a) an isometric view, (b) on a symmetrical plane

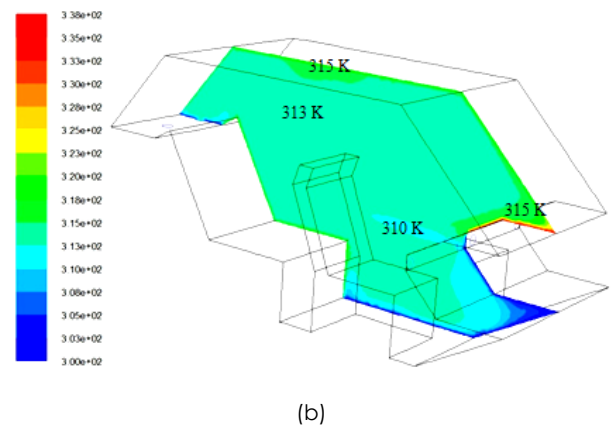

**Figure 15** Distribution of air temperature inside the car compartment when three ventilation fans were placed at the rear deck: (a) an isometric view, (b) on the symmetrical plane

Figure 15 shows the air temperature distribution when three ventilation fans were placed at the rear deck. Clearly, the region of air having a temperature of 313 K (40°C) is a lot bigger now, covering almost the entire rear region of the compartment. On the symmetrical vertical plane we can clearly see that this region extends from the rear deck to the front of the dashboard and closed to the windscreen, roof and the floor. For this case we found that the average air temperature inside the passenger compartment is about 311 K (38°C). This suggests that the average air temperature can potentially be reduced further by placing three ventilation fans on the rear deck instead of just two. In this case a temperature reduction of 10°C was achieved which represents a 20.8% improvement compared to the case when no ventilation fans were used.

Figure 16 shows the air temperature distribution inside the passenger compartment when two ventilation fans were placed at the middle of the roof. The distribution of air temperature appears to have a nearly similar pattern as that for the previous case. A large portion of the air at the rear section of the compartment can be seen at a temperature of 313 K (40°C). This region of air temperature can be clearly seen on the vertical symmetrical plane of the compartment. It extends vertically from the roof to the floor and horizontally from the rear deck to the front of the dashboard. Close to the windscreen the air is at a temperature of 315 K (42°C) while below the dashboard the air has the lowest temperature of 303 K (30°C). For this case, we found that the average air temperature is about 313 K (40°C). This shows that when two ventilation fans are placed at the middle of the roof, the air temperature inside the passenger compartment can potentially be reduced by 8.3°C, which represents a 17.4 % reduction.

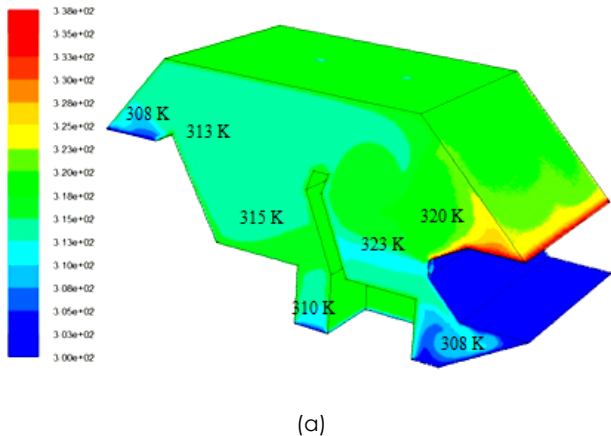
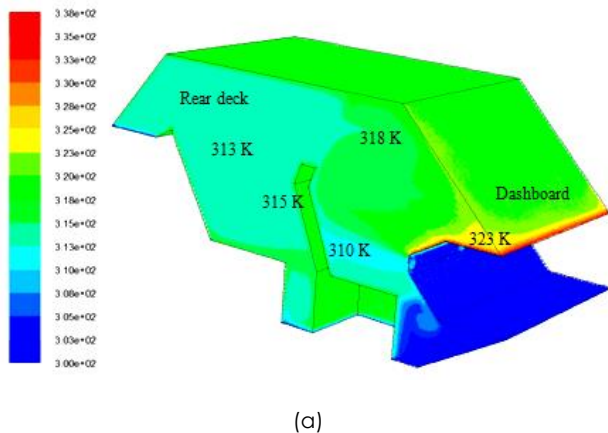

(a)

(a)

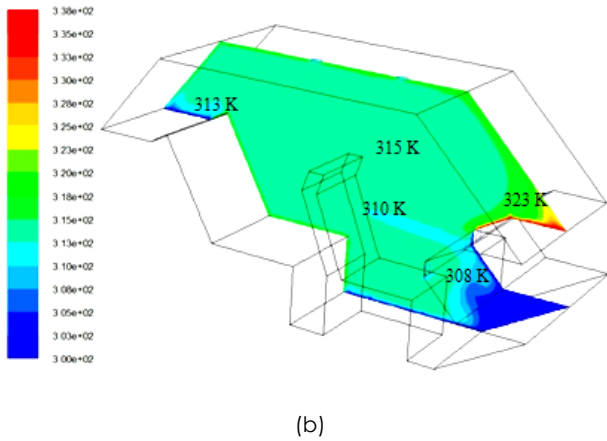

**Figure 16** Distribution of air temperature inside the passenger compartment when two ventilation fans were placed at the roof: (a) an isometric view, (b) on a symmetrical plane

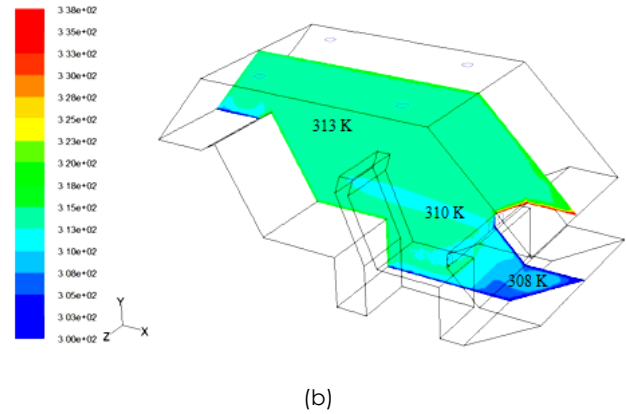

**Figure 17** Distribution of air temperature (in Kelvin) inside the passenger compartment when four ventilation fans were placed at the roof: (a) isometric view, (b) on a symmetrical plane

Figure 17 shows the air temperature distribution inside the passenger compartment when four ventilation fans were placed at the roof. As we would expect the region of air having a temperature of 313 K (40°C) gets larger when more ventilation fans are placed at the roof. This can clearly be seen on the vertical symmetrical plane of the passenger compartment in figure (b). As in the previous case, this region of air extends vertically from the roof to the floor and horizontally from the rear deck to the vicinity of the dashboard and the front windscreen. The air below the dashboard is at lot lower temperature, varying between 308 K (35°C) to 310 K (37°C). For this case we found that the average air temperature inside the passenger compartment is about 310 K (37°C). This shows that the average air temperature can potentially be lowered by 10.7°C, which represents a 22.2 % temperature reduction.

The results above clearly indicate that the use of ventilation fans could potentially lower the average air temperature inside the passenger compartment when the car was parked in the open space under the sun. The results also indicate that the placement and the number of ventilation fans used have considerable effects on the percent of temperature reduction that can be attained. In the last case, we examined the effect of increasing the air velocity at the ventilation fans from 2.84 m/s to 15.67 m/s, when four fans are placed at the roof.

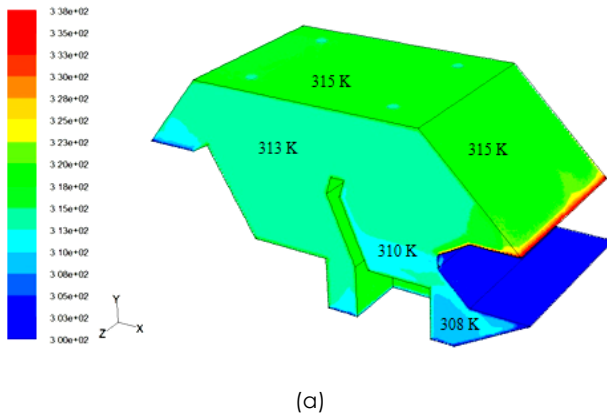
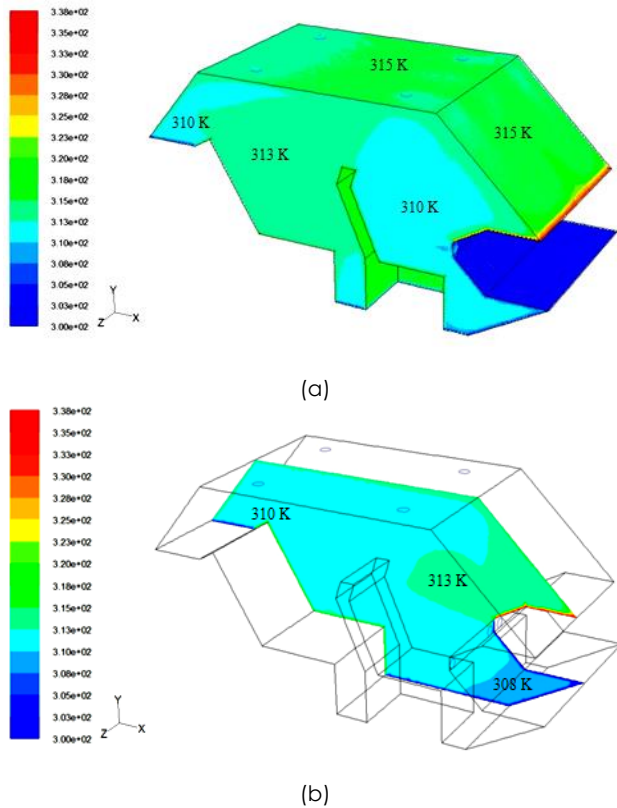

Figure 18 shows the air temperature distribution inside the passenger compartment when four ventilation fans were placed at the roof in which the outlet air velocity at each fan was increased from 2.84 m/s to 15.67 m/s. We can see in figure (a) that the air at the rear section of the compartment is almost entirely at a temperature of 313 K (40°C) while that at the frontal section including the air below the dashboard is at a temperature of 310 K (37°C). The air closed to the roof and the front windscreen appears to be at a temperature of 315 K (42°C). On the vertical symmetrical plane shown in figure (b), we can observe that the region of air at a temperature of 310 K (37°C) extends vertically from the roof to the floor section and horizontally from the rear deck to the vicinity of the dashboard. The air in front of the windscreen appears to be at a temperature of 313 K (40°C) while the air below the dashboard is at 308 K (35°C). We found that for this case the average air temperature inside the passenger compartment is 309 K (36°C). This result shows that the average air temperature can potentially be lowered by 11.3°C which represents a 23.6 % temperature reduction. This result shows that increasing the outlet air velocity at the ventilation fans to 15.67 m/s has only a marginal affect on the average air temperature inside the passenger compartment.



**Figure 18** Distribution of air temperature (in Kelvin) inside the passenger compartment when four ventilation fans were placed at the roof, with air flow velocity of 15.67 m/s: (a) isometric view, (b) on a symmetrical plane

The results on the use of ventilation fans on the average air temperature inside the passenger compartment of the car are summarized in Table 3.

**Table 3** Summary of CFD simulation results

Without ventilation fans, the average air temperature inside the passenger compartment at 1 pm, $T_{avg} = 48^{\circ}\text{C}$			
No. of fans	Fan Location	Air velocity, $V = 2.84 \text{ m/s}$	Air velocity, $V = 15.67 \text{ m/s}$
		Temperature reduction, %	Temperature reduction, %
2	Rear deck	8.3°C; 17.4%	-
3	Rear deck	10°C; 20.8%	-
2	Roof	8.3°C; 17.4%	-
4	Roof	10.7°C; 22.2%	11.3°C; 23.6%

### 4.0 CONCLUSION

In this article, the effects of using the ventilation fans on the air temperature inside the passenger compartment of a car parked openly under the sun at a time of 1 pm were investigated using CFD method. The effects of fan location, number of the ventilation fans used and the air velocity at the ventilation fans on the average air temperature were also examined. It was found that, from measurement without the ventilation fans, the air inside the

passenger compartment could rise to 48°C. Result of the CFD simulation shows that a 17% temperature reduction is achieved if two ventilation fans with airflow velocity of 2.84 m/s are placed at the rear deck. When three fans are installed at the rear deck, a further temperature reduction of 3.4% can be attained. Placing two ventilation fans at the middle of the roof produces 17% temperature reduction in the compartment. When four fans are placed at the roof, a further 4.8% temperature reduction is obtained. Increasing the airflow velocity of the four fans at the roof, from 2.84 m/s to 15.67 m/s, give only a marginal reduction in the air temperature inside the passenger compartment.

### Acknowledgement

The authors would like to acknowledge the supports from Universiti Teknologi Malaysia and fund provided by the Ministry of Higher Education (MOHE), Malaysia throughout this study under the FRGS Vot No. 4F645 and to UTM-PROTON Future Drive Laboratory for providing the authors a necessary assistance to conduct the field measurements.

### References

- [1] Levinson, R., Pan, H., Ban-Weiss, G., Rosado, P., Paolini, R. and Akbari, H. 2011. Potential Benefits of Solar Reflective Car Shells: Cooler Cabins, Fuel Savings and Emission Reductions. *Applied Energy*. 88(12): 4343-4357.
- [2] Johnson, V.H. 2002. Fuel Used for Vehicle Air-Conditioning: A State-by-State Thermal Comfort-Based Approach. *Fuel*. 1: 1957.
- [3] Kamar, H.M., Ahmad, R., Kamsah, N.B. and Mustafa, A.F.M. 2013. Artificial Neural Networks for Automotive Air-Conditioning Systems Performance Prediction. *Applied Thermal Engineering* 50(1): 63-70.
- [4] Rugh, J.P., Hendricks, T.J. and Koram, K. 2001. Effect of Solar Reflective Glazing on Ford Explorer Climate Control, Fuel Economy, and Emissions. *In Proceedings of the International Body Engineering Conference*. 2001, October
- [5] Farrington, R.B., Anderson, R., Blake, D.M., Burch, S.D., Cuddy, M.R., Keyser, M.A. and Rugh, J.P. 1999. Challenges and Potential Solutions for Reducing Climate Control Loads in Conventional and Hybrid Electric Vehicles. *National Renewable Energy Laboratory, Golden, CO, USA* retrieved April, 01, 2013, from: [www.ott.doe.gov/coolcar/pubs.html](http://www.ott.doe.gov/coolcar/pubs.html).
- [6] Farrington, R.B., Brodt, D.L., Burch, S.D. and Keyser, M.A. 1998. Opportunities to Reduce Vehicle Climate Control Loads. *In Proc. 15th Electric Vehicle Symp., Brussels*. Sept. 1998.
- [7] Saidur, R., Masjuki, H.H. and Hasanuzzaman, M. 2009. Performance of an Improved Solar Car Ventilator. *International Journal of Mechanical and Materials Engineering*. 4(1): 24-34.
- [8] Bharathan, D., Chaney, L., Farrington, R. B., Lustbader, J., Keyser, M., and Rugh, J. 2007. An Overview of Vehicle Test and Analysis from NREL's A/C Fuel Use Reduction Research. *In Vehicle Thermal Management Systems Conf & Exh*. 2007 (VTMS-8).
- [9] Rugh, J., Chaney, L., Lustbader, J., Meyer, J., Rustagi, M., Olson, K. and Kogler, R. 2007. Reduction in Vehicle Temperatures and Fuel Use from Cabin Ventilation, Solar-Reflective Paint, and a New Solar-Reflective Glazing. *SAE Technical Paper*. 11194: 2007.

- [10] Huang, K.D., Tzeng, S.C., Ma, W.P. and Wu, M.F. 2005. Intelligent Solar-Powered Automobile-Ventilation System. *Applied Energy*. 80(2): 141-154.
- [11] Dadour, I.R., Almanjahie, I., Fowkes, N.D., Keady, G. and Vijayan, K. 2011. Temperature Variations in a Parked Vehicle. *Forensic Science International*. 207(1): 205-211.
- [12] Jasni, M.A. and Nasir, F.M. 2012. Experimental Comparison Study of the Passive Methods in Reducing Car Cabin Interior Temperature. In *International Conference on Mechanical, Automobile and Robotics Engineering (ICMAR'2012)*. Penang, Malaysia: 229-233.
- [13] Ivanescu, M., Neacsu, C.A. and Tabacu, I. 2010. Studies of the Thermal Comfort of the Passenger Compartment Using Numerical Simulation. In *2010 International Congress Motor Vehicles and Motors, Kragujevac, October 7th-9th, 2010*. MVM2010-026.
- [14] Neacsu, C., Ivanescu, M. and Tabacu, I. 2009. *The Influence of the Glass Material on the Car Passenger's Thermal Comfort* retrieved April, 01, 2013, from: [http://automotive.upit.ro/index\\_files/2009/2009\\_B\\_16\\_.pdf](http://automotive.upit.ro/index_files/2009/2009_B_16_.pdf)
- [15] Neacsu, C.A., Ivanescu, M. and Tabacu, I. 2009. The Influence of the Solar Radiation on The Interior Temperature of the Car. In *2009 European Social Fund (ESFA), Bucharest*.
- [16] Zhang, H., Dai, L., Xu, G., Li, Y., Chen, W. and Tao, W.Q. 2009. Studies of Air-Flow and Temperature Fields Inside a Passenger Compartment for Improving Thermal Comfort and Saving Energy. Part I: Test/Numerical Model and Validation. *Applied Thermal Engineering*. 29(10): 2022-2027.
- [17] Sevilgen, G. and Kilic M. 2013. Investigation of Transient Cooling of an Automobile Cabin With a Virtual Manikin Under Solar Radiation. *Thermal Science*. 17(2): 397-406.
- [18] Aroussi, A., Hassan, A. and Morsi, Y. 2003. Numerical Simulation of the Airflow over and Heat Transfer Through a Vehicle Windshield Defrosting and Demisting System. *Heat and Mass Transfer*. 39(5-6): 401-405.
- [19] Zhang, D. and Weng, P. 2007. Numerical Simulation and Experiment Research of Air Organization in Air-Conditioned Passenger Car. In *Building Simulation*.
- [20] Kilic, M. and Sevilgen, G. 2009. Evaluation of Heat Transfer Characteristics in an Automobile Cabin with a Virtual Manikin During Heating Period. *Numerical Heat Transfer Part A: Applications*. 56 (6): 515-539.
- [21] Sevilgen, G. and Kiliç, M. 2010. Transient Numerical Analysis of Airflow and Heat Transfer in a Vehicle Cabin During Heating Period. *International Journal of Vehicle Design*. 52 (1-4): 144-159.
- [22] Fluent, I.N.C., 2006. FLUENT 6.3 user's guide. *Fluent Documentation*