

THE GREEN CONSTRUCTION SITE INDEX (GCSI): A QUANTITATIVE TOOL USED TO ASSESS AN ONGOING PROJECT TO MEET THE GREEN CONSTRUCTION CONCEPT

Ferry Firmawan^{1*}, Fadil Othman¹, Khairulzan Yahya¹, Zaiton Haron¹

¹ Faculty of Civil Engineering, Universiti Teknologi Malaysia, 81310 UTM Johor Bahru, Malaysia

(Received: November 2015 / Revised: March 2016 / Accepted: April 2016)

ABSTRACT

The development of the construction industry in Indonesia has been substantially contributing to the enhancement of the social and economic development of the people. However, its expansion has also become an issue, as the development might be implicated in the abuse of environmental sustainability when the practices of conducting the construction project abandon the rules and regulations of sustainable green construction concepts. Therefore, this study attempted to introduce a quantitative assessment tool called the Green Construction Site Index (GCSI) to evaluate the performance of an ongoing project to meet the sustainable green construction concept. The aim of this study was to investigate the effectiveness of GCSI as a quantitative assessment tool to measure the implementation of the green construction concept conducted by ongoing projects. Data were collected by onsite direct observation, interviews with key personnel, and project documentation review. Data were organized and analyzed using descriptive elaboration. The results showed that three aspects, the Efficiency Index (I_E), Productivity Index (I_P), and Awareness Index (I_A), were effective in assessing 10 ongoing construction projects, categorized as Non-Commercial Non-Residential Building, Commercial Residential Building, and Commercial Non-Residential Building. The index generated using GCSI, upon assessing 10 buildings, was 3.39 and fell into the Good category with $I_E = 3.51$, $I_P = 2.86$, and $I_A = 3.84$. Another finding shows that the Project Organizational Commitment Index (POCI) to the indicator of the GCSI was 3.31 (Good category) with $I_{POL} = 3.36$, $I_{PRO} = 3.49$, and $I_{PRAC} = 2.75$. The capability of the GCSI to identify three aspects within a construction project simultaneously and comprehensively suggests the importance of its function as an effective tool that gives benefits to not only the contactors, but also to the authorities that control the green construction-related performance. Therefore, the GCSI is expected to be applied as a standardized reference by both the construction industries and regulating authorities. Despite its satisfactory findings, the GCSI needs to be furthered to achieve its reliability and validity to be adopted internationally.

Keywords: GCSI; Concept; POCI; Project; Tool

1. INTRODUCTION

The steady increase of social and economic development in Indonesia has stimulated the growth of the construction industry and has triggered the escalation of many supporting systems related to the construction industry. As a consequence, the government has to control those industries to comply with the regulations in order to protect both the industries and the environment from

*Corresponding author's email: ferryfirmawan@yahoo.com, Tel. +6-07-5531581, Fax. +6-07-5566157
Permalink/DOI: <http://dx.doi.org/10.14716/ijtech.v7i4.2660>

any possible negative impact generated by strict competition among the industries.

For example, as the demand for housing increases, the activities of the construction industry will also increase. The multiplier effect sometimes forces the construction industry to disregard the negative implications to the environment. As a result, the deterioration of the environment has become a central issue. Firmawan et al. (2012a) identified that the establishment of an infrastructure influences the construction industry, which directly influences the development of a nation; however, the construction industry also generates severe impacts to the environment (Bossink & Brouwers, 1996).

The negative impact of the construction industry on the environment has been recognized as one of the world's largest problems because it occurs in many countries. A considerable number of studies concerning environmental problems associated with construction activities has been carried out (Shen et al., 2005; Tam & Lee, 2007; Ofori & Ekanayake, 2004; Gangolells et al., 2009). Such as the fact that resource depletion, considerable amount of waste and high energy consumption are needed by construction industry (Kim et al., 2006) that lead the industry becomes one of the biggest environmental polluters (Yahya & Boussabaine, 2006). Most of the findings concluded that in order to serve industrial activities, a high number of raw materials, such as soil, aggregates, sand, and water, must be consumed by the construction industry to manufacture goods, such as bricks, cement, plasterboard, metals (steel and iron), timber, concrete, and plaster. This process generates a large quantity of construction waste that has significant negative impacts on the environment.

Realizing the negative impact of the construction industry to the environment, both the construction industry and the government should be working together and functioning dependently to resolve the adverse impact of development to the environment. To develop this mutual understanding, both sides need a tool that functions as a controlling system to fulfill any requirement toward the achievement of the sustainable green construction concept.

Given this situation, many experts and institutions have developed environmental concern-related tools used by many countries worldwide. For example, Leadership in Energy and Environmental Design (LEED) developed a rating system that focuses on environmental conservation and green design and construction features (U.S.G.B.C., 2009); Management Performance Evaluation Tools (WMPET/Korea) developed an evaluation tool to assess the performance level for a particular construction site (Kim et al., 2006); Building Waste Assessment Score (BAWAS/Singapore) applied a multi-attribute value technique used to develop building waste assessment (Ofori & Ekayake, 2004); Environmental Performance Assessment - Environmental Operational Indicators (EPA-EOIs/Hong Kong and Australia) promoted a tool used to assess the major inputs including resources, energy, and other aspects of facilities and equipment, which relate to: i) design, operation, and maintenance; ii) material, energy, product, service, waste, and emission; and iii) supply of materials, energy, and services to and the delivery of product associated with the organization's physical facilities and equipment (Tam & Lee, 2007). Other scholars have also reported such findings; however, few have put emphasis on the performance assessment of an ongoing project from a perspective that covers their interrelated problems, for instance, the commitment of project management to avoid negative impacts of the construction industry, especially in Indonesia (Firmawan et al., 2012).

Therefore, in order to identify tools that are adaptable to the Indonesian environment, this study considers the importance of having a comprehensive tool with the capability to employ all aspects involved in a construction project. This study emphasizes developing a quantitative tool that can quantify efficiency, productivity, and awareness so that the result will be comprehensive, accurate, and recommendable. The aim of this study was to investigate the

effectiveness of GCSI as a quantitative assessment tool to measure the implementation of a green construction concept conducted by ongoing projects.

The Green Construction Site Index (GCSI) and Project Organization Commitment Index (POCI) tools this study has been attempting to formulate were constructed from 133 factors taken from 12 recognizable world tools. The 133 factors were categorized into 25 major factors, and then grouped into 5 elements. Lastly, the five elements are classified into three indicators, namely the Efficiency Index (I_E), Productivity Index (I_P), and Awareness Index (I_A). The result is the GCSI. Meanwhile, the POCI is constructed from 25 major factors categorized into 3 categories, namely policy, procedure, and practice.

The GCSI works to quantify three indicators involved in construction industry practices. Therefore, the construction industry will be able to supervise, monitor, and control the working process of a project. Once an element of a construction project is conducted improperly, management will be able to identify core problems. The advantages a construction project benefits from will also be enjoyed by the government as the result of the assessment, called an index, can be considered an input in helping make a decision.

2. LITERATURE REVIEW

Many have reported that construction industries create and provide advantages for human needs, facilities, and social developments; however, they also have been aware of and studying the implications of the construction industry on the environment in terms of its adverse influences. Lau and Whyte (2007) reported that a high quantity of waste, produced by demolition, renovation, and activities related to construction, was the major contributor to degraded environments. Bossink and Brouwers (1996) also pointed out that construction has had a significant negative effect on the environment. Previously, Kim et al. (2006) reported that a large amount of waste generation, resource depletion, and high energy consumption is closely related to the construction industry; therefore, according to Yahya and Boussabaine (2006), the construction industry becomes one of the biggest environmental polluters.

Meanwhile, according to Yahya and Boussabaine (2006), as a high amount of raw materials is needed in the construction industry, a large quantity of waste is also generated, causing significant negative impacts on the environment. The fact is that raw materials (aggregates, sand, soil, and water) and manufactured goods (cement, bricks, metal-based material, timber, plasterboard, concrete, cement, and plaster) are needed to serve industries. In this case, the waste of the material means abandoned and unusable materials generated in a large quantity from construction activities that create extensive environmental impacts.

Graham and Smithers (1996) explained that the significant factors that cause waste in construction projects occur in the stage of design and material procurement. In terms of the materials, the major sources of construction waste were demolition waste, roadwork material, excavated material, site clearance, and renovation waste (EPD, 1992; Poon et al., 2001). In addition, Masudi et al. (2011) reported that the main factors for construction waste generation are the type of building, design, and size of project, and site management.

In a broader perspective, many countries worldwide have generated a lot of construction waste. According to Rogoff and Williams (1994), construction waste contributed approximately 29% of solid waste in the USA. Moreover, scholars revealed that 20–30% of all deposited waste in Australian landfills was produced by construction activity (Craven et al., 1994). Meanwhile, Ferguson et al. (1995) reported that in the UK, waste in construction took up more than 50% of UK landfill and 35% of Canadian landfill. In USA, the volume of C&D waste taken up its landfill was approximately one-third of the existing materials (Chun Li et al., 1994; Kibert, 2000).

One significant point to be addressed is that all previous research findings intensively studied the implication caused by the development of the construction industry from a specific point of view, as previously discussed. Meanwhile, construction projects as an entity have a complex structure involving policy (Nitivattananon & Borongan, 2007), management (Poon et al., 2001a, 2001b; Tam, 2008), work forces (Alwi et al., 2000), process (Lau et al., 2008; Marsudi et al., 2011; Graham et al., 1996), and cost (Graham et al., 1996).

3. METHODOLOGY

3.1. Tool Development

In the process of developing the tool, several steps were taken into account, starting from collecting related references from associated resources, analyzing the findings and classifying them into a manageable list of factors, testing and sorting them into a set of factors, and formulating them into a systematic questionnaire design. The tool supplies a reliable instrument by which an ongoing project of three types of buildings is assessed from two perspectives: GCSI and POI. Meanwhile, recommendation furnishes the output of the assessment with suggestable recommendation following the weaknesses found that should be further taken into account. Figure 1 shows the flowchart of the research methodology and the phase of the action to be performed.

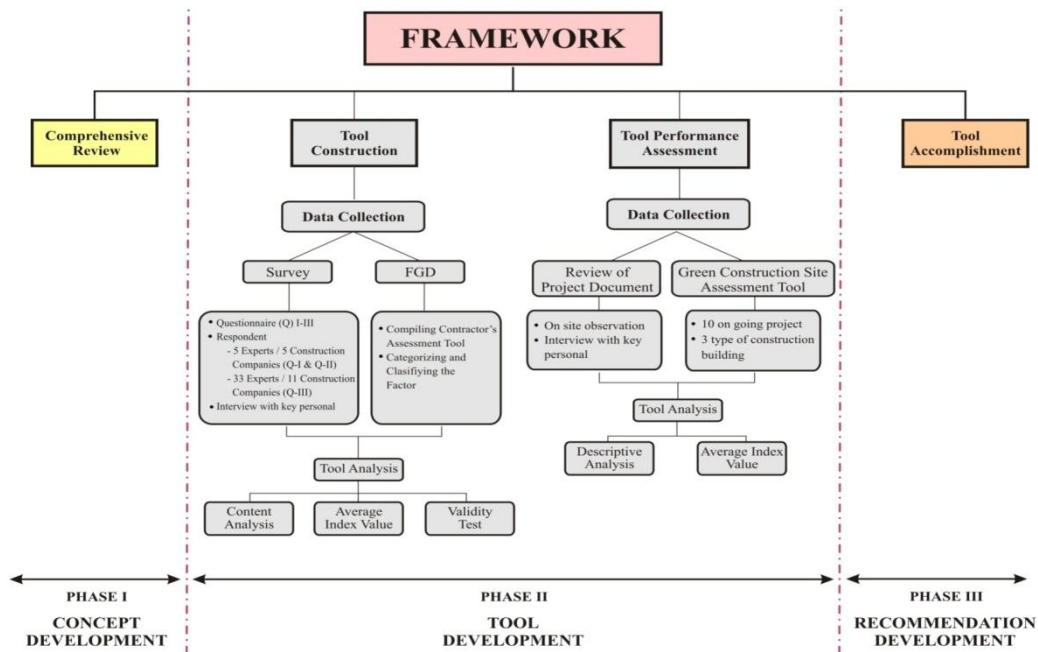

Figure 1 Research methodology framework

3.2. Tool Implementation

3.2.1. Samples

The sample assessed using GCSI and POI was 10 ongoing projects categorized into three types of construction buildings: two projects of type I (Non-Commercial Non-Residential Buildings included a university building in Makasar and a government office in Ogan Ilir), four projects of type II (Commercial Residential Buildings included a resort in Kuta Bali, an Army dormitory in Jakara, a residential tower in Jakara, and an apartment building in Surabaya), and four projects of types III (Commercial Non-Residential Buildings included hospital buildings in Sentul and Bandung, an office building in Semarang, and Juanda Airport Terminal in Sidoharjo). The samples were chosen as a representation of buildings that were closely related to the environmental concerns.

3.2.2. Procedure

Data collected were taken in three stages. First, the participants were asked to respond to the questionnaire sent by mail and/or email. The results were tabulated and analyzed using a scoring/index system. The participants were field workers, field supervisors, and managers. Second, in order to validate the score achieved from the questioner, onsite observation and interviews with key personnel were carried out. Third, official project documents were reviewed. Focus group discussion (FGD) was conducted several times with key personnel from each project in the central office of a project to discuss the findings. The results were interpreted by combining the data collected from the sites and the FGD conducted by comparing, sorting out, and combining each set of data.

3.2.3. Analysis

Data compiled were analyzed based on three indicators, namely the Efficiency Index (I_E), Productivity Index (I_P), and Awareness Index (I_A) for GCSI and the Policy Index (I_{POL}), Procedure Index (I_{PRO}), and Practice Index (I_{PRAC}) for POCI. The level of achievement was categorized into four groups.

Table 1 The level of achievement

Index	Achievement
3.75 – 5.00	Excellent
2.50 – 3.74	Good
1.25 – 2.49	Need Improvement
0.00 – 1.24	Lack of Commitment

4. RESULTS AND DISCUSSION

4.1. GCSI

The Tool Performance Assessment consists of 133 validated factors categorized into 25 major factors classified into 5 elements. The five elements, then, are grouped into three indicators, namely the Efficiency Index (I_E), Productivity Index (I_P), and Awareness Index (I_A). The Tool Performance Assessment functions to assess an ongoing project by indicating the existence or not of the 133 factors. The result, which is called the index, exhibits the GCSI an ongoing project has achieved. The validation of the factors is summarized in Table 2.

Table 2 Tool construction

Objectives	Data to be Verified	Source/Respondents	Analysis Tool
Sorting out the factors of Green Construction Concept	205 factors of questions taken from 18 sources into 181 factors	FGD 5 experts from 5 leading state-owned construction companies	Purposive Sampling
Sorting out the factors of Green Construction Concept	181 factors of questions taken from 18 sources into 130 factors	FGD 5 experts from 5 leading state-owned construction companies	Average Index
Categorizing and Classifying the factors of Green Construction Concept	130 factors of questions taken from 18 sources plus 27 factors from existing contractor’s Quantitative Assessment Tools (QAT) into 157 factors	FGD 5 experts from 5 leading state-owned construction companies	Qualitative Analysis
To validate factors which are suitable & appropriate for GCSI	157 factors of questions into 133 factors	3 senior project managers from 11 state-owned enterprise construction companies	Validity Test

Table 2 shows the process of the tool development that covers the objective of each stage, the data to be verified, the source and respondents, and the tool of analysis. Meanwhile, the outline of the development of the GCSI and of the POCI is described in Figure 2.

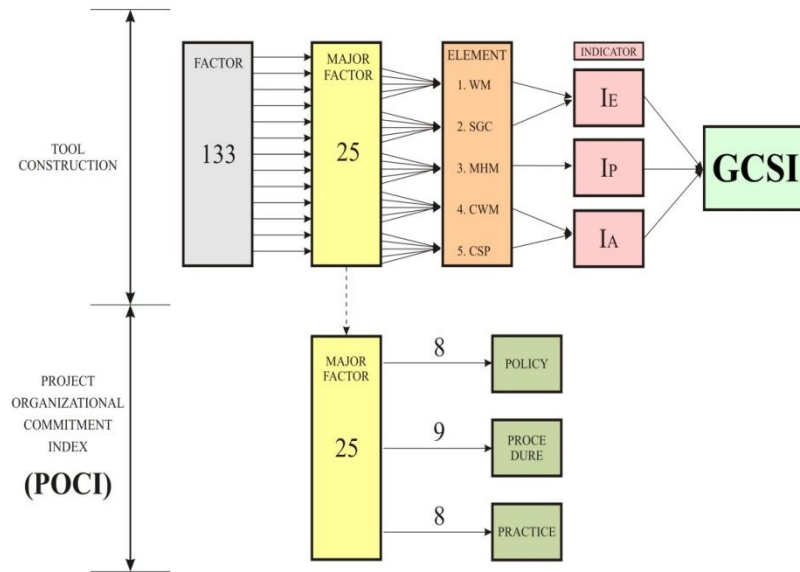

Figure 2 The outline of the development of GCSI and POCI

4.1.1. Efficiency index (I_E)

Data gathered collected from 10 projects confirmed the effectiveness of the GCSI in assessing two elements of waste minimization and sustainable green construction. Each element is constructed based on five major factors, each of which is formed from five to seven factors. Every factor measured exposes the degree of efficiency a project is carrying out, which is scored by an index. The Efficiency Index of every aspect exhibit the degree of achievement a project is being carried out as shown in Table 3.

Table 3 Efficiency Index of 10 projects observed

Element	Construction Project										Average
	Type I			Type II				Type III			
	1	2	3	4	5	6	7	8	9	10	
1. Waste Minimization	3.00	2.40	3.80	3.00	4.00	4.40	3.40	4.20	3.60	2.60	3.44
2. Sustainable Green Construction	3.20	3.00	4.00	3.00	4.80	4.20	3.00	4.00	3.60	3.00	3.58
Average	3.10	2.70	3.90	3.00	4.40	4.30	3.20	4.10	3.60	2.80	3.51

3.75 – 5.00 = Excellent
 2.45 – 3.74 = Good
 1.25 – 2.44 = Need Improvement
 0.00 – 1.24 = Lack of Commitment

Type I : Non-Commercial Non-Residential Building
 Type II : Commercial Residential Building
 Type III : Commercial Non-Residential Building

Table 3 shows that the average of the Efficiency Index of 10 projects assessed is 3.51, from which the waste minimization and sustainable green construction scores are 3.44 and 3.58, respectively. The table reveals that the index of project #2 of Non-Commercial Non-Residential Building (type I) and of project #10 of Commercial Non-Residential Building (type III) is 2.70 and 2.80, respectively, or falls into the Good category. However, the smallest score caused by the failure of these two projects to perform well in implementing Waste Minimization from which the index they obtain is 2.40 and 2.60, respectively. Meanwhile, three projects of type II

belong to the Good category and another one falls into Excellent category. For type III, project #8 is in the Excellent category and projects #7 #9 and #10 are in the Good category.

4.1.2. Productivity index (I_p)

Productivity, the second indicator of GCSI, is an equally important indicator because productivity reflects the performance achievement of both efficiency and awareness. In reconstructing GCSI, productivity is measured by the performance of a factor called material handling management, which uses five major factors to assess the field practices of a project. These variables are: 1) the establishment of material application procedures on the construction site, 2) material selection and utilization, 3) material wastage assessment, 4) controlling of the reinforcement bar (rebar) waste, and 5) controlling of concrete waste. The IP of the 10 ongoing projects is exhibited in Table 4.

Table 4 Productivity Index based on material handling management

Major Factor	Construction Project										Tot	Index
	Type I			Type II				Type III				
	1	2	3	4	5	6	7	8	9	10		
1. Establishment of Material Application Procedures on Construction Site	2	3	4	4	2	3	3	1	3	2	29	2.90
2. Material Selection and Utilization	4	3	3	4	4	4	4	4	4	4	38	3.80
3. Material Wastage Assessment	0	1	2	1	0	0	0	0	2	0	6	0.60
4. Controlling of Reinforcement Bar (Rebar) Waste	4	3	2	3	3	3	2	1	2	4	27	2.70
5. Controlling of Concrete Waste	4	3	5	5	5	5	5	3	4	4	4	4.30
Total	14	13	16	17	14	15	14	9	15	14	143	
Index	2.8	2.6	3.2	3.4	2.8	3.0	2.8	1.8	3.0	2.8		2.86

3.75 – 5.00 = Excellent 2.45 – 3.74 = Good 1.25 – 2.44 = Need Improvement 0.00 – 1.24 = Lack of Commitment	Type I : Non-Commercial Non-Residential Building Type II : Commercial Residential Building Type III : Commercial Non-Residential Building
---	---

Table 4 shows that the material handling management element of 10 projects has an average index of 2.86 (Good category). Among the 10, the lowest index is 1.80 and the highest index is 3.40.

The table clearly shows that all projects of all types of construction building perform well, except project #8 of type III, which receives the lowest score (1.80, Need Improvement category). The lower performance of the material handling management element is caused by the fact that not all major factors assessed are applied in the field level, especially material wastage assessment. Six projects abandon to practice.

From the major factor point of view, the lowest index is 0.60 (material wastage assessment) and the highest one is 4.30 (controlling of concrete waste). Three indicators are likely to be considered less important (establishment of material application procedures on construction site, material wastage assessment, and controlling of reinforcement bar (rebar) waste) compared to the other two. This data can be interpreted that all contractors put more emphasis on the Building Construction Cost Index than other parameters.

Research performed by the University of Alberta indicated that productivity is a complex issue, as many factors influence productivity such as labor, capital, material, and equipment. Lack of correct materials, tools, and equipment; poor communication or relationship between workers and management; disorganized projects, poor supervision, lack of cooperation and communication between different crafts; lack of worker participation in the decision-making process; and unfair workloads are the some of the factors that affect productivity (Productivity Alberta, 2008). Technical problems like inadequate designs or incomplete engineering work can also lead to a backlog in productivity. Similarly, restrictive and redundant procedures also affect the effectiveness of a project (Dozzi and Abourizk, 1993).

4.1.3. Awareness index (IA)

The complexity to ensure the goal of a sustainable green construction concept for a project is performed has been realized, as it involves all aspects of a project structure such as policy, procedure, and practice. Sustainable construction means cities and buildings that respond to the emotional and psychological needs of people by providing stimulating environments, raising awareness of important values, inspiring the human spirit, and bonding societies, communities, and neighborhoods (sustainable construction, 2007).

The performance of the awareness indicator among the 10 projects observed will be discussed by elaborating on data gathered from two major factors: Construction Site Performance and Construction Waste Management. Table 5 exhibits the performance of awareness among 10 projects observed.

Table 5 The Awareness Index of 10 projects observed

Element	Construction Project										Average
	Type I		Type II					Type III			
	1	2	3	4	5	6	7	8	9	10	
1. Construction Site Performance	3.6	4.4	3.8	4.0	3.8	3.4	3.6	4.0	4.8	4.4	4.02
2. Construction Waste Management	4.0	3.8	2.6	3.6	3.2	4.0	4.2	3.4	4.6	3.6	3.66
Average	3.8	4.1	3.2	3.8	3.5	3.7	3.9	3.7	4.7	4.0	3.84

3.75 – 5.00 = Excellent
 2.45 – 3.74 = Good
 1.25 – 2.44 = Need Improvement
 0.00 – 1.24 = Lack of Commitment

Type I : Non-Commercial Non-Residential Building
 Type II : Commercial Residential Building
 Type III : Commercial Non-Residential Building

Table 5 shows the Awareness Index of 10 projects assessed gaining 3.84, from which the score of Construction Site Performance and Construction Waste Management is 4.02 and 3.66, respectively. The three types of construction building perform relatively well proven by the index they obtain. Projects #1 and #2 of type I and projects #7, #9 and #10 of type III fall into the Excellent category. The rest fall into the Good category.

As a quantitative assessment tool, GCSI evaluates factual activities a project is carrying out by observing these activities on the spot in a real time. Therefore, the index a project produces reveals the real performance of a contractor or construction company in meeting the sustainable green construction concept. The comprehensiveness of the green construction tool is validated by its faculty to analyze every factor, indicator, and variable that relates to the effort to fulfill the sustainable green construction concept.

To understand how this tool effectively works, Table 6 reviews the achievement of the 10 projects.

Table 6 The Performance of 10 projects assessed using GCSI

Indicator	Construction Project										Average
	Type I			Type II				Type III			
	1	2	3	4	5	6	7	8	9	10	
1. Efficiency	3.10	2.70	3.90	3.00	4.40	4.30	3.20	4.10	3.60	2.80	3.51
2. Productivity	2.80	2.60	3.20	3.40	2.80	3.00	2.80	1.80	3.00	2.80	2.86
3. Awareness	3.80	4.10	3.20	3.80	3.50	3.70	3.90	3.70	4.70	4.00	3.84
Average	3.23	3.31	3.43	3.40	3.56	3.66	3.30	3.20	3.76	3.20	3.39
Avg.	3.27			3.51				3.36			3.39

3.75 – 5.00 = Excellent
 2.45 – 3.74 = Good
 1.25 – 2.44 = Need Improvement
 0.00 – 1.24 = Lack of Commitment

Type I : Non-Commercial Non-Residential Building
 Type II : Commercial Residential Building
 Type III : Commercial Non-Residential Building

The average index of 10 projects assessed is 3.39 (Good category); however, among the three parameters, awareness performed by 10 projects Excellent category as the GCSI they earn is 2.86 (Good), while the Efficiency Index and Productivity Index is 3.51 and 3.86, respectively. Although the other two indicators fall into Good category, there are still some major factors and elements that the need to be improved in order to meet the criteria of the Excellent category.

4.2. POCI

As previously discussed, the quantitative assessment of GCSI is not only capable of assessing an ongoing project from the perspective of efficiency, productivity, and awareness, but it is also proficient in identifying the commitment of a project organization from the point of view of policy (top management), procedure (middle management), and practice (field workers) using the Policy Index (I_{POL}), Procedure Index (I_{PRO}), and Practice Index (I_{PRAC}), respectively. The tool used to measure it is called POCI. By having been able to measure comprehensively and thoroughly every major factor, element, and indicator of an ongoing project, the POCI will be able to provide a degree of commitment of the organization and to offer a recommendation to a project that its index is unsatisfied to the project management.

To understand the commitment of each level of a project organization, Table 7 summarizes the findings using POCI.

Table 7 The POCI of 10 ongoing projects

Stage of Perspective	Construction Project										Average
	Type I			Type II				Type III			
	1	2	3	4	5	6	7	8	9	10	
1. Policy Level	3.25	4.00	2.63	4.13	3.38	2.88	3.50	3.75	3.88	4.00	3.54
2. Procedure Level	3.67	3.56	2.89	4.11	3.56	3.56	3.44	3.56	3.56	4.00	3.59
3. Practice Level	3.00	3.63	3.50	3.63	3.25	3.13	3.00	3.25	3.88	3.38	3.36
Average	3.31	3.73	3.00	3.96	3.40	3.19	3.31	3.52	3.77	3.79	3.50
	3.52			3.39				3.60			3.50

3.75 – 5.00 = Excellence
 2.45 – 3.74 = Good
 1.25 – 2.44 = Need Improvement
 0.00 – 1.24 = Lack of Commitment

Type I : Non-Commercial Non-Residential Building
 Type II : Commercial Residential Building
 Type III : Commercial Non-Residential Building

From the organization point of view, Table 7 shows that the commitment of middle management in completing their responsibility is the highest (I_{PRO} = 3.59), followed by top management or policy level (I_{POL} = 3.54) and field workers (I_{PRAC} = 3.36). Meanwhile, from the accomplishment point of view, the POCI of project #3 is the lowest (POCI = 3.00) and of

project #4 is the highest (POCI = 3.96). All projects of all types of construction buildings the fell into the Good category, but projects #4, #9, and #10 were in the Excellence category. Moreover, from the type of construction project, construction project of type III has the highest commitment (POCI = 3.60), followed by type I (POCI = 3.52) and then type II (POCI = 3.39).

Many scholars have suggested the importance considering waste minimization and sustainable green construction, as their negative impact to the environment has been deeply realized. Current literature on lean construction that focused on the occurrence of materials waste onsite highlights various forms of waste relating to operations and processes including time, overproduction, defects in products, unnecessary processing (Ohno, 1988), accidents, and suboptimal working conditions (Koskela, 2000). Meanwhile, type of building, design, and size of a project and site management are also main factors for construction waste amount (Masudi et al., 2011) and the major sources of construction waste consist of roadwork material, excavated material, demolition waste, site clearance, and renovation waste (EPD, 2003; Poon, et al., 2001a, 2001b).

Waste management strategies have also been suggested to reduce waste at the addressed sources. One of the ways to reduce waste is through the reuse of secondhand materials and the use of materials with recycled content (Treloar, 2003). He additionally explained that based on actual costs of secondhand materials and estimates of the embodied energy savings, it was found that the cost savings could total 40% of the building price, while the embodied energy savings could be as high as 70% of the total embodied energy of the building.

The second point that needs to be discussed is the comprehensiveness of the GCSI, which assesses not only the parameter of efficiency but also the degree of commitment in three project domains: policy level, procedure level, and practice level. The commitment of an officer in any level of an organizational structure has to be identified to understand the extent to which their responsibility to achieve green construction concept is dedicated.

The following table reviews the interrelationship between the indicator of efficiency and the commitment of the contractor organization summarized from the 10 projects assessed. Table 8 displays the relationship between the construction project organizational level and the indicator of the GCSI.

Table 8 The POCI to the indicator of the GCSI

Indicator	Commitment Index			Average
	Policy	Procedure	Practice	
1. Efficiency	3.67	2.96	3.96	3.53
2. Productivity	3.60	3.25	0.60	2.52
3. Awareness	3.76	4.26	3.60	3.87
Average	3.68	3.49	2.75	3.31

3.75 – 5.00 = Excellence
2.45 – 3.74 = Good
1.25 – 2.44 = Need Improvement
0.00 – 1.24 = Lack of Commitment

Table 8 shows that some problems occur whenever personnel within the project organization conduct their responsibilities to meet the requirement of the GCSI. The most serious problem deals with the indicator of productivity. At the field level, the policy from the top manager and site manager level is neglected by field workers (index = 0.60 falls into the Lack of Commitment category). On the other hand, the site manager level has a problem with management level in carrying out the indicator of efficiency (index = 2.96 falls into the Good category). Overall, the commitment index to fulfill the requirement of the GCSI needs to be

focused on developing the competence of field workers to adopt the sustainable green construction concept. Another point to be considered is the improvement of the organization to increase productivity.

The broad coverage of POCI provides conclusive quantitative assessment that encompasses three stages; policy level, procedure level, and practice level. In achieving the goal of the green construction concept, each stage has to “link and match” one to another so that the controlling mechanism will work well. The controlling mechanism will effectively work if a quantitative assessment tool is available and is able to identify the performance of an ongoing process of a project. In addition, this tool also proves to be working well for three types of construction building, in this case, Non-Commercial Non-Residential Building, Commercial Residential Building, and Commercial Non-Residential Building. As far as this matter is concerned, there is currently no tool available to do so. Therefore, the existence of GCSI will significantly assist a project in meeting the green construction concept.

5. CONCLUSION

The effectiveness of the GCSI is proven by its capability to assess an ongoing project from three perspectives that cover almost all aspect related to the construction project. The effectiveness of this quantitative assessment tool is marked by its ability to complete its function on the spot and in real time. Therefore, the data observed could be analyzed at the same time the work is being completed and the results and recommendations can be accessed directly in the field and handed over to the users. The first perspective is technicality-related parameters that quantitatively measure the efficiency, productivity, and awareness of a project. Data gathered from 10 projects summarized that these three parameters thoroughly and accurately calculated the strengths and weaknesses of each major factor and element of an ongoing project. The second perspective refers to cross-examination between the three indicators and the commitment of every person involved in the organizational structure level of the construction project. This method proved to be effective in determining the degree of commitment that personnel, in any level of the organization, have to the three indicators. The degree of commitment is quantitatively measured so that the relationship between these two aspects can be analyzed and a conclusion can be drawn to be given as a recommendation. The third perspective is the capability of these tools to cross-examine between the three indicators and the type of construction building (Non-Commercial Non-Residential Building, Commercial Residential Building, and Commercial Non-Residential Building). The result showed that the type of the construction building was closely related to the achievement of each indicator, either positive or negative. Most importantly, the GCSI is proficient in quantitatively exposing the degree of the relationship.

6. SUGGESTIONS

6.1. For Contractor

As the sustainable green construction concept is becoming a worldwide approach to valuing the competence of a contractor to produce a construction project, an effective tool is needed to serve as the controlling mechanism. The GCSI is formulated based on criteria of many tools developed by many experts to embed and adjust to the characteristics of Indonesia. Therefore, the implementation of this tool needs to be considered as an opportunity for the contractor to control an ongoing project effectively.

6.2. For Authorities

In line with the development of the construction industry in Indonesia, the government should supervise any construction project to achieve the sustainable green construction concept. To do

so, a tool to control and recommend an ongoing project is imperative. As a new method that will be implemented in Indonesia, the GCSI is a logical option to be considered.

7. REFERENCES

- Alberta Finance and Enterprise (AFE), 2008. Highlight of the Highlights of the Alberta Economy. Available online at: <http://www.albertacanada.co/statpub>
- Alwi, S., 2003. Factors Influencing Construction Productivity in the Indonesian Context. In: *Proceedings of the Eastern Asia Society for Transportation Studies*, Volume 4
- Alwi, S., Hampson, K., Mohamed, S., 2000. Waste in the Indonesian Construction Projects. In: *Proceeding of CIB W107 1st International Conference: Creating a Sustainable Construction Industry in Developing Countries*. 11–13 November, Stellenbosch, South Africa
- Alwi, S., Hampson, K., Mohamed, S., 2002. Non Value-adding Activities: A Comparative Study of Indonesian and Australian Construction Projects. In: *Proceedings of the Tenth Annual Conference of the International Group for Lean Construction IGLC-10*, Gramado, Brazil
- Begum, R.A., Pereira, J.J., Siwar, C., Jaafar, A.H., 2007. Implementation of Waste Management and Minimization in the Construction Industry of Malaysia. *Resources, Conservation and Recycling*, Volume 51(1), pp. 190–202
- Begum, R.A., Pereira, J.J., Siwar, C., Jaafar, A.H., 2009a. Attitude and Behavioral Factors in Waste Management in Construction Industry in Malaysia. *Resources, Conservation and Recycling*, Volume 53(6), pp. 321–328
- Begum, R.A., Pereira, J.J., Siwar, C., Jaafar, A.H., 2009b. Contractors' Willingness to Pay for Improving Cons Waste Management in Malaysia. *Construction Research Institute of Malaysia (CREAM) Journal*, Volume 4(1)
- Begum, R.A., Siwar, C., Pereira, J.J., Jaafar, A.H., 2006. A Benefit–cost Analysis on the Economic Feasibility of Construction Waste Minimization: The Case of Malaysia. *Resources, Conservation and Recycling*, Volume 48, pp. 86–98
- Bossink, B.A.G., Brouwers, H.J.H., 1996. Construction Waste: Quantification and Source Evaluation. *Journal of Construction Engineering and Management*, Volume 122(1), pp. 55–60
- Chun-Li, P., Grosskopf, K.R., Kibert, C.J., 1994. Construction Waste Management and Recycling Strategies in the United States. In: *Proceedings of the First Conference of CIB TG 16 on Sustainable Construction*. Tampa, FL: Centre for Construction and Environment, pp. 689–696
- Craven, E.J., Okraglik, H.M., Eilenberg, I.M., 1994. Construction Waste and a New Design Methodology: Sustainable Construction. In: *Proceedings of the First Conference of CIB TG 16 on Sustainable Construction*, pp. 89–98
- Dainty Andrew R.J., Brooke, R.J., 2004. Towards Improved Construction Waste Minimisation: A Need for Improved Supply Chain Integration? *Structural Survey*, Volume 22(1), pp. 20–29
- Dozzi, S.P., AbouRizk, S.M., 1993. *Productivity in Construction*. Institute for Research in Construction. National Research Council, Ottawa, Ontario, Canada
- Environmental Protection Agency (EPA), U.S., Available online at: <http://www.epa.gov>
- Environmental Protection Department (EPD), Hong Kong, Available online at: <http://www.info.gov.hk/epd>
- Ervianto, W.I., Soemardi, B.W., Abduh, M., Suryamanto, 2011. Assessment Model Development Green Construction at Construction Process for Construction Project in Indonesia. *National Conference of Postgraduate Civil Engineering*

- Faniran, O.O., Caban, G., 1998. Minimizing Waste at Construction Project Sites. *Engineering, Construction, and Architectural Management*, Volume 5(2), pp. 182–188
- Ferguson, J., Kermod, N., Nash, C.L., Sketch, W.A.J., Huxford, R.P., 1995. *Managing and Minimizing Construction Waste: A Practical Guide*. Thomas Telford Publications, London
- Firmawan, F., 2006. Occurrence Cause Analysis Many Variables Deviation against Material Cost Indicator Material Cost Overrun. *Most Influential Journal Foundations*, Volume 12(2), pp. 112–126
- Firmawan, F., 2012b. Green Construction Policy menuju Pembangunan Perumahan dan Kawasan Pemukiman Ramah Lingkungan. Proceedings of *Green Urban Housing Policy*, Faculty of Engineering, UNDIP. pp. 79–85 [in Bahasa]
- Firmawan, F., Othman, F., Yahya, K., 2012a. Framework for Green Construction Assessment: A Case Study of Government Institution Building Project in Jakarta, Indonesia. *Journal of Emerging Trends in Engineering and Applied Sciences (JETEAS)*, Volume 3(4), pp. 576–580
- Gangolells, M., Casals, A., Gasso, S., Forcada, N., Roca, X., Fuertes, A., 2009. A Methodology for Predicting the Severity of Environmental Impacts Related to the Construction Process of Residential Buildings. *Building and Environment*, Volume 44, pp. 558–571
- Gavilan, R.M., Bernold, L.E., 1994. Source Evaluation of Solid Waste in Building Construction. *Journal of Construction Engineering & Management*, Volume 120(3), pp. 536–552
- Graham, P., Smithers, G., 1996. Construction Waste Minimisation for Australian Residential Development. *Asia Pacific Journal of Building & Construction Management*, Volume 2(1), pp. 14–19
- Kibert, C., 2008. *Sustainable Construction*, John Wiley & Sons, Canada
- Kim, J.H., Kim, J.M., Cha, H.S., Shin, D.W., 2006. Development of the Construction Waste Management Performance Evaluation Tool (WMPET). *ISARC*
- Koskela, L., 2000. *An Exploration towards a Production Theory and Its Application to Construction*. Espoo, Finland: VTT Publication No. 408
- Lau et al., 2008. Composition and Characteristics of Construction Waste Generated by Residential Housing Project. *International Journal of Environmental Research*, Volume 2(3), pp. 261–268
- Lau, H.H., Whyte, A., 2007. A Construction Waste Study for Residential Projects in Miri, Sarawak. *Conference on Sustainable Building South East Asia*, 5–7 November, Malaysia
- Masudi, A.F., Che Hassan, C.R., Mahmood, N.Z., Mokhtar, S.N., Sulaiman, N.M., 2011. Construction Waste Quantification and Benchmarking: A Study in Klang Valley, Malaysia. *Journal of Chemistry and Chemical Engineering*, Volume 5(10), pp. 909–916
- McDonald, B., Smithers, M., 1998. Implementing a Waste Management Plan during the Construction Phase of a Project: A Case Study. *Construction Management and Economics*, Volume 16, pp.71–89
- Nitivattananon, V., Borongan, G., 2007. Construction and Demolition Waste Management: Current Practices in Asia. In: *Proceedings of the International Conference on Sustainable Solid Waste Management*, 5–7 September, Chennai, India, pp. 97–104
- Ofori, G., Ekanayake, L.L., 2000. Construction Material Waste Source Evaluation. In: *Proceedings of Strategies for a Sustainable Built Environment*, Pretoria, 23–25 August
- Ofori, G., Ekanayake, L.L., 2004. Building Waste Assessment Score: Design-based Tool. *Building and Environment*, Volume 39, pp. 851–861
- Ohno, T., 1988. *Toyota Production System*. Cambridge, MA: Productivity
- Poon, C.S., Jaillon, L., Chiang, Y.H., 2009a. Quantifying the Waste Reduction Potential of Using Prefabrication in Building Construction in Hong Kong. *Journal of Waste Management*, Volume 29, pp. 309–320

- Poon, C.S., Yu, A.T.W., Ng, L.H., 2001a. On-Site Sorting of C&D Waste in Hong Kong. *Resources, Conservation and Recycling*, Volume 32, pp. 157–172
- Poon, C.S., Yu, A.T.W., Wong, S.W., Cheung, E., 2004b. Management of Construction Waste in Public Housing Projects in Hong Kong. *Construction Management and Economics*, Volume 22(7) pp. 675–689
- Poon, C.S., Yu, T.W., Ng, L.H., 2001b. *A Guide for Managing and Minimizing Building and Demolition Waste*. Hong Kong: Hong Kong Polytechnic University Publishing
- Rogoff, M., and Williams, J.F., 1994. *Approaches to Implementing Solid Waste Recycling Facilities*, Noyes, Park Ridge, N
- Shen, L.Y., Lu, W.S., Yao, H., Wu, D.H., 2005. A Computer-based Scoring Method for Measuring the Environmental Performance of Construction Activities. *Automation in Construction*, Volume 14, pp. 297–309
- Siagian, I.S., 2005. *Eco-Friendly Building Materials*. Universitas Sumatera Utara [in Bahasa]
- Suprpto, H., Wulandari, S., 2009. Study on Construction Waste Management Model during Construction Project Development Implementation. In: *Proceeding PESAT (Psikologi, Ekonomi, Sastra, Arsitektur & Sipil)*, Volume 3 [in Bahasa]
- Tam, V.W.Y., Wang, J.Y., Kang, X.P., 2008a. An Investigation of Construction Waste: An Empirical Study in Shenzhen. *Journal of Engineering, Design and Technology*, Volume 6(3), pp. 227–236
- Tam, V.W.Y., 2008b. On the Effectiveness in Implementing a Waste-management-plan Method in Construction. *Journal of Waste Management*, Volume 28(6), pp. 1072–1080
- Tam, V.W.Y., Le, K.N., 2007. Assessing Environmental Performance in the Construction Industry. *Surveying and Built Environment*, Volume 18(2), pp. 59–72
- Treloar G.J., Gupta H., Love P.E.D., Nguyen, B., 2003. An Analysis of Factors Influencing Waste Minimisation and Use of Recycled Materials for the Construction of Residential Buildings. *Management of Environmental Quality*, Volume 14(1), pp. 134–145
- U.S.G.B.C. 2009. *Green Building Design and Construction, LEED Reference Guide for Green Building Design & Construction*, USA, pp. i–xiv, 335–400
- Yahya, K., Boussabaine, A.H., 2006. Eco-costing of Construction Waste. *International Journal of Environmental Quality Management*, Volume 17(1), pp. 6–19
- Yahya, K., Boussabaine, A.H., 2010. Quantifying Environmental Impacts and Eco-Costs from Brick Waste. *Architectural Engineering and Design Management*, Volume 6, pp. 189–206