

## FOULING EFFECT ON CONTROLLER TUNING IN MEMBRANE BIOREACTOR FILTRATION PROCESS

Zakariah Yusuf, Norhaliza Abdul Wahab\*

Control and Mechatronic Engineering Department, Faculty of Electrical Engineering, Universiti Teknologi Malaysia, 81310 Johor Baharu, Johor Malaysia

### Article history

Received

23 August 2016

Received in revised form

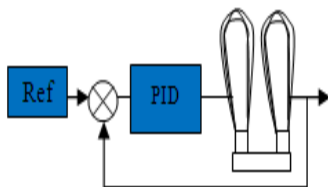
30 October 2016

Accepted

7 November 2016

\*Corresponding author  
aliza@fke.utm.my

### Graphical abstract



### Abstract

This paper presents an initial investigation on controller tuning with the effect on membrane fouling in submerged membrane bioreactor (SMBR). This work employed proportional integral derivative (PID) controller to control SMBR filtration process. The PID controller is tuned using three different methods which are Ziegler Nichols (ZN), Cohen Coon (CC) and integral time-weight absolute error (ITAE) tuning. The PID controller is used to control the SMBR filtration permeate flux. Transmembrane pressure (TMP) was observed during the filtration process that will determine fouling effect on controller tuning. The simulation work is done using artificial neural network (ANN) model that was developed in our previous work. Different set points were tested to see the robustness of the controller tuning. The overall result shows the ITAE tuning method performs better compare with other tuning methods in term of its overshoot, settling time and integral absolute error (IAE) with 0.66%, 9.1 second and 82.68 respectively. This tuning method provides precise control performance in the same time it will prevent from decrement of flux in the filtration cycle.

**Keywords:** Membrane filtration process, Fouling, PID controller Tuning

### Abstrak

Kertas kerja ini membentangkan siasatan awal pada penalaan pengawal dengan kesan ke atas membran fouling dalam bioreaktor membran tenggelam (SMBR). Kerja ini bekerja berkadat pengawal terbitan penting (PID) untuk mengawal proses penapisan SMBR. PID pengawal ditala dengan menggunakan tiga kaedah yang berbeza yang Ziegler Nichols (Zn), Cohen Coon (CC) dan ralat mutlak penalaan penting masa-berat (ITAE). PID pengawal digunakan untuk mengawal penapisan SMBR. Tekanan transmembran (TMP) dipantau semasa proses penapisan dan kesannya kepada penalaan pengawal diperhatikan. Kerja-kerja simulasi dilakukan dengan menggunakan model jaringan saraf tiruan (ANN) yang telah dibangunkan dalam kerja-kerja kami sebelum ini. Beberapa percubaan pada set-titik yang berbeza dilakukan bagi memastikan talaan adalah berkesan. Hasilnya menunjukkan kaedah penalaan ITAE prestasi yang lebih baik berbanding dengan kaedah penalaan lain diuji dari segi lajakkkan, masa penetapan dan IAE dengan masing-masing 0.66%, 9.1 saat dan 82.68. Kaedah penalaan menyediakan prestasi kawalan yang tepat dalam masa yang sama ia akan menghalang dari susutan fluks dalam kitaran penapisan.

**Kata kunci:** Proses penapisan Membran, Fouling, Penalaan sistem Kawalan PID

© 2016 Penerbit UTM Press. All rights reserved

## 1.0 INTRODUCTION

In recent years, membrane technology has become significantly important in filtration systems in many applications. Membrane technology is a very useful technology in filtration system especially in solid liquid separation process [1]. Combination of membrane technology with bioreactor has created technology call membrane bioreactor (MBR). MBR has found to be a reliable technology to replace the conventional activated sludge (CAS) process for water and wastewater treatment process. This technology has proved its capability in producing high standard of wastewater effluent[2].

However, membrane bioreactor has its own disadvantages which are membrane fouling and significant energy consumption in the filtration process [3]. A fouling phenomenon is caused by many factors such as colloidal, particulate, and solute materials. Membrane fouling is a complex process, affected by many parameters, including the operation, influent properties, and the membrane itself [4]. Fouling will affect the overall performance of a filtration system in the long run, by inducing incremental filtration resistance, as a result of the compact formation of fouling on the membrane surface[5].Fouling can lead to a membrane clogging, resulting in that the membrane pore will be blocked by solid material. When this phenomenon occurs, the filtration pressure measured by transmembrane pressure (TMP) will increase. The clogging on the membrane also will reduce the permeate flux output and the same time the overall system efficiency will be effected.

Uncontrollable pressure rises in filtration will lead to membrane damage that can cause increment of the operating cost due to the membrane maintenance and replacement[6]. Manipulation of flux flow rate is very important in membrane filtration system. It can be utilize to reduce fouling by adjusting the permeate set point when necessary [7].

Even though MBR technology is introduce for many years ago, the application of control system in MBR system still not mature. At the moment, open loop control system still implement in many MBR plant[8]. Application of advance control system for SMBR process is very challenging task and needs a lot of understanding of the system operation and dynamic. Some successful implementation of close loop control has shown that the application of controller has gives improvement to the system and process[8].

Proportional integral derivative (PID) controller is still the main controller used in many industries. This controller is very popular because of its simplicity and simple to understand. In addition, the controller is very stable and easy to be tuned. Curcio *et al.* [9] presents the PI and PID control application to the UF membrane filtration process. Simulation of the system was done using hybrid neural network model. The controllers were used to control the permeate flux of the filtration process. The controllers were tuned using

zigler-nichols (ZN) and ITAE tuning methods. The authors found ITAE tuning method is more robust both in regulator and servo problem in preventing flux decline during filtration process.

PID controller was used for permeate flux control in submerged anaerobic membrane bioreactor [10]. However, PID controller was found produce high overshoot at the initial filtration cycle that can cause poor filtration performance. This is cause by the ON and OFF stages in the filtration system. In order to solve this problem, fixed frequency with PID controller was introduce to control the permeate pump. The PID controller also chooses by the authors to control mix liquor level in the plant.

The PID controller also is applied in MBR plant to control aeration process in the aerobic process in order to maintain the dissolve oxygen level at appropriate level [11]. Several PID tuning methods are available in literature to meet the requirement of the process control criterion. ZN is among the first tuning method developed and it can be useful initial tuning information on the controller design. Another popular tuning method is Cohen-coon (CC) technique. Similar with the ZN tuning, the CC also can be a good starting point in tuning a PID controller. This two tuning method is usually become the benchmark for the latest and advance tuning methods. Tuning based on the performance criterion was among the reliable and effective technique. Many successful implementation reported in the literature such as in. [9][12] and [13].

## 2.0 METHODOLOGY

### 2.1 SMBR Filtration Model

The model used in this work is taken from our previous work in [14]. This model is a artificial neural network (ANN) model with recurrent structure where the past output and input is used to predict the current output. This structure is also known as nonlinear auto regressive with exogenous input (NARX). Figure 1 show the model structure employed in this work.

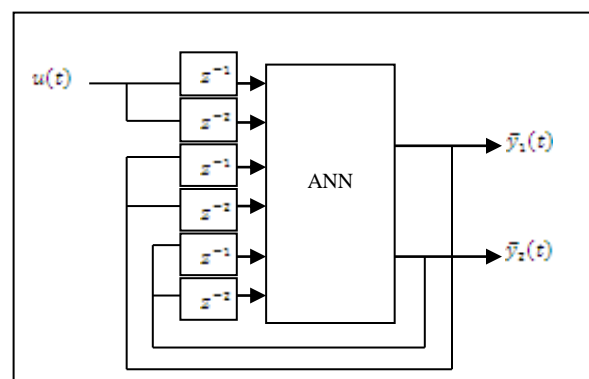


Figure 1 Neural Network Structure

$u(t)$  is the voltage applied to the permeate pump while,  $\hat{y}_{1(t)}$  and  $\hat{y}_{2(t)}$  is the predicted permeate flux and TMP respectively.  $z^{-1}$  is the delay operator.

The data collection is done by using random step test to the permeate pump. This will excite the dynamic of the filtration process. 50 percent of the data is used to construct the neural network model using selected training method, while another 50 percent is used for testing the neural network accuracy. Figure 2 shows the plot of collection.

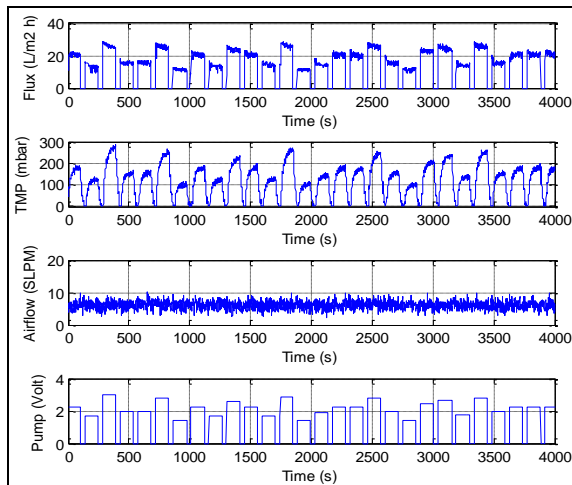


Figure 2 experiment data

## 2.2 PID Controller

PID controller is a three term controller that representing proportional integral and derivative. The equation of PID controller is given by equation (1).

$$u(t) = K_p e(t) + K_p K_i \int_{t=0}^{\infty} e(t) dt + K_p K_d \frac{de(t)}{dt} \quad (1)$$

Laplace transform of this equation given by:

$$K(s) = \frac{U(s)}{e(s)} = \left(1 + \frac{K_i}{s} + K_d s\right) K_p \quad (2)$$

where the constant parameters of the algorithm given by:

$$K_p = K_c, K_i = 1/T_i s, K_d = T_d s$$

where  $K_p$  is the proportional gain,  $K_i$  is the Integral gain and  $K_d$  is the derivative gain.  $e(t)$  is the error between set point and actual value. The general idea of PID is that the proportional gain will have the effect of reducing the rise time but not reduce the steady-state error. Integral gain of PID controller will eliminate the steady-state error but the excessive of this gain will make transient response worse. A derivative gain will help with improving the transient response.

## 2.3 Ziegler-Nichols Tuning

Ziegler Nichols tuning method developed based on the dynamic properties of the process. Equation (3) represents the tuning method by Ziegler Nichols reaction curve method [15].

$$K_c = 1.2 / (K \theta / T_c); T_i = 2\theta; T_d = 0.5\theta \quad (3)$$

where  $T_c$  is the time constant,  $\theta$  is the time delay.

## 2.4 Cohen-Coon Tuning

Cohen and coon presented more complex equation compare with the ZN tuning method. The objective of this tuning technique is to achieve 25% damping ratio of the controller step response. The equation for three terms PID controller tuning is given in equation (4), [15].

$$\begin{aligned} K_c &= (\tau_d / 4T_c + 4/3) / (K \tau_d T_c) \\ T_i &= \tau_d ((3\tau_d) / 4T_c + 4) / (\tau_d / T_c + 13/8) \\ T_d &= \tau_d 2 / (\tau_d / T_c + 11/2) \end{aligned} \quad (4)$$

where  $T_c$  is the time constant,  $\tau_d$  is the time delay.

## 2.5 ITAE Tuning

ITAE is one of the most effective techniques for PID controller tuning. The ITAE tuning is developed to minimize the performance error criterion [15]. Equation (5) presents the ITAE tuning equation.

$$\begin{aligned} K_c &= 0.965 / K (\theta / T_c)^{0.855} \\ T_i &= T_c / (0.796 - 0.147(T_d / \theta)) \\ T_d &= 0.308(T_c / \theta)^{0.929} \end{aligned} \quad (5)$$

## 2.6 Experiment Setup

The experiments were carried out in single tank submerged membrane bioreactors, with working volume of 20 L palm oil mill effluent (POME) taken from Sedenak Palm Oil Mill Sdn. Bhd. in Johor, Malaysia. The working temperatures for the bioreactors were at  $29 \pm 1$  °C. The plant was operated with 120 second permeate and 30 second for relaxation period. The airflow rate is maintained around 6-8 LPM. Figure 3 shows the pilot plant setup for the experiment. The data plant was controlled and monitored using National Instruments, Labview 2009 software with NI USB 6009 interfacing hardware.

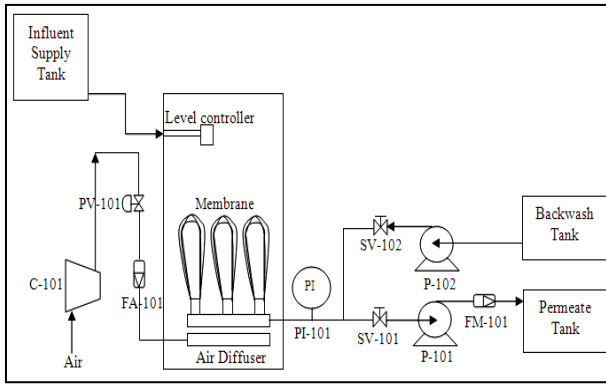


Figure 3 Schematic Diagram of the Submerged MBR

Table 1 shows the list of instruments used in the pilot plant development.

Table 1 List of Instruments/Parts

Tag No	Description
C-101	20L 2HP Air compressor
PV-101	Proportional Valve
FA-101	Airflow Sensor
PI-101	Pressure Transducer
SV-101	Solenoid Valve Permeate Stream
SV-102	Solenoid Valve Backwash stream
P-101	Peristaltic Pump
P-102	Diaphragm Pump
FM-101	Liquid Flow Meter
Membrane	Hollow Fiber Membrane

In this work, Polyethersulfone (PES) material with approximately 80-100kda pore size membrane was used in the filtration system.

Figure 4 presents the software interfacing for the SMBR pilot plant. The software is capable to monitoring and control of the pilot plant. The software also include of data logging and trending.

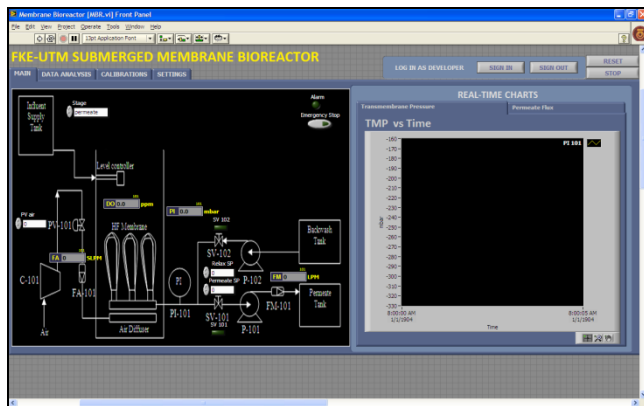


Figure 4 Software interfacing for the SMBR pilot plant

### 2.7 Filtration Measurement

The TMP during filtration was measured using WIKA pressure transducer ranging from -1 to 1.5 bar. The

permeate flux of the filtration was measured using RS 508-2704 flow sensor range from 0.05 to 10 liter per minute (LPM). The permeate flux equation is given by equation (6).

$$J = V / At \tag{6}$$

Where  $J$  is the permeate flux in ( $l/m^2 h$ ),  $V$  is the volume flow rate in liter and  $t$  is the time (h). The airflow was measured using Honeywell airflow sensor AWM5104V ranging from 0 to 20 standard liter per minute (SLPM) while the Watson Marlow peristaltic pump is used for permeate suction. Figure 4 shows the data collected from the experiment.

### 3.0 RESULTS AND DISCUSSION

From the two cycles simulation, the result indicate application of PID controller allow better control of permeate flux compare with without controller (open loop). Without controller application, the permeate flux is decreasing approaching at the end of the cycle. This happens due to fouling build during the membrane filtration process. In term of tuning techniques, ITAE method performs better compare with ZN and CC techniques. Similar performance was by [12] in other application. Figure 5 presents the PID controller with various techniques and the comparison with open loop control.

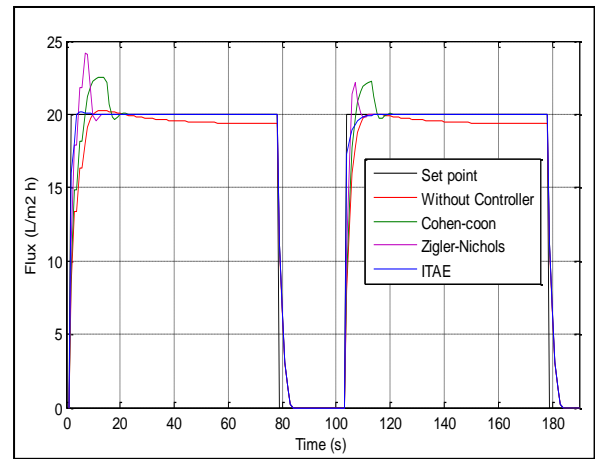


Figure 5 Two cycles without and with PID controller

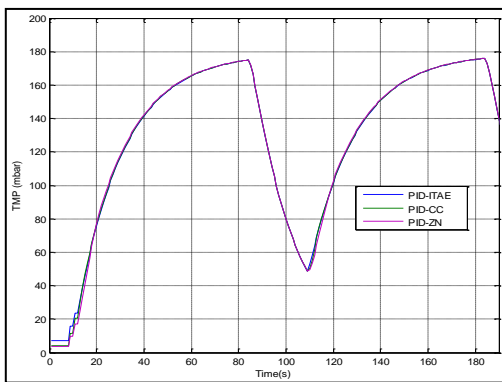
Performance of the controller for permeate flux control is measured using three criterion which are percentage overshoot, settling time and integral absolute error (IAE). In term of percentage overshoot, ITAE perform better only 0.66% compared with CC and ZN at 12.63 and 20.64 respectively. The settling time performance indicate, ITAE tuning technique settle at 9.1 second while ZN tuning at 17.3 second. The CC tuning method only achieved steady state at 24.8 second. The IAE performance shows ITAE gives less error with 82.68. The ZN and CC tuning methods perform at 113.6 and 142.1 respectively. Table 2

presents step response performance of the PID tuning technique.

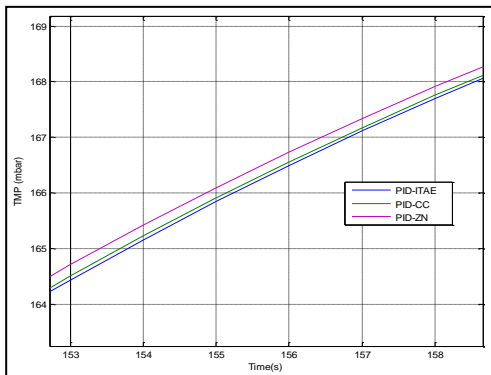
**Table 2** Step response performance of PID controller

Tuning	%Overshoot	Settling Time (sec.)	IAE
ZN	20.64	17.3	113.6
CC	12.63	24.8	142.1
ITAE	0.66	9.1	82.68

The TMP effect on the controller tunings were presented in Figure 6 while the zoom to the TMP curve was presents in Figure 7. The result shows only small different between all tuning method. The controller with high overshoot creates faster TMP increment during filtration process.

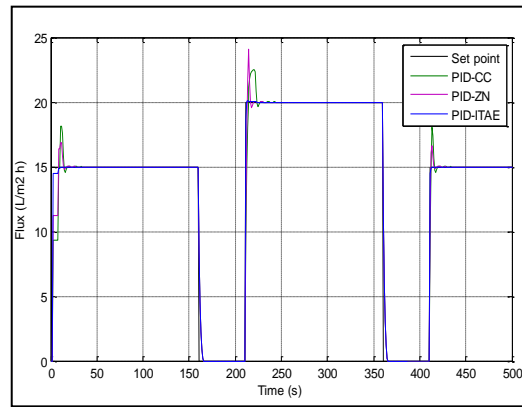


**Figure 6** TMP effect during filtration process



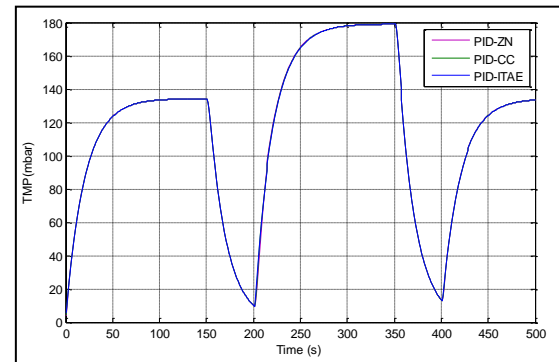
**Figure 7** zoom at the TMP curve

For the set point change simulation, it can be observed that the ITAE tuning perform better response at all set point compared with the ZN and CC tuning. It also observed that the ZN and CC tuning give high overshoot at all cycle. Figure 8 shows the set point change controller performance.

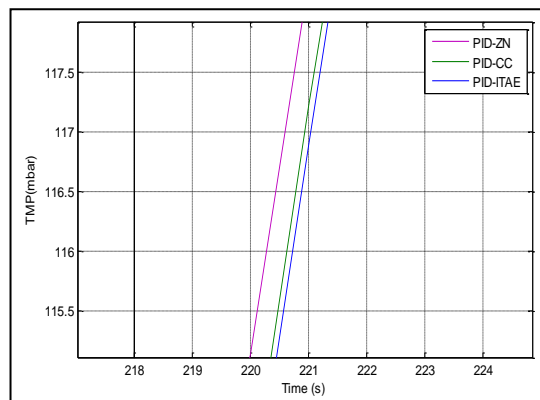


**Figure 8** Set point change

Similar with the single set point simulation, it can be observed that the high overshoot controller cause fastest TMP increment. Figure 9 presents the TMP effect of the filtration and Figure 10 is zoom of TMP at the second cycle.



**Figure 9** TMP effect on set point change



**Figure 10** zoom at second cycle

#### 4.0 CONCLUSION

This paper presents the preliminary study on the application of PID controller and its tuning method to the submerged membrane bioreactor filtration

control. This work is performed using simulation process from the neural network model developed in previous work. The simulation results show the application of PID controller gives better permeate flux control compared to without controller. Permeate flux in open loop control will cause decreasing of the flux due to fouling development. From the results also it can be concluded that the ITAE tuning method is capable to tune PID controller for SMBR filtration control. From the simulation result the ITAE performs the lowest overshoot, settling time and IAE compared with the Cohen-Coon and Ziegler-Nichols tuning techniques. In terms of the TMP effect on the tuning technique, it shows that the tuning only gives small effect to the TMP. The higher overshoot controller response will cause higher TMP increment compared with less overshoot tuning. In the long term operation it may cause faster fouling development in the filtration cycle.

### Acknowledgement

The authors would like to thank the Research University Grant (GUP) vote 13H70, Universiti Teknologi Malaysia for the financial support. The first author wants to thank the Universiti Teknologi MARA (UiTM) and the MOE for the TPM-SLAI scholarship.

### References

- [1] S. Judd. 2008. The Status Of Membrane Bioreactor Technology. *Trends Biotechnol.* 26(2): 109-116.
- [2] S. Judd. 2010. *The MBR Book Principles and Applications of Membrane Bioreactors in Water and Wastewater Treatment*. Second Ed. Elsevier.
- [3] I. Chang, P. Le Clech, B. Jefferson, and S. Judd. 2002. Membrane Fouling in Membrane Bioreactors for Wastewater Treatment. *J. Environ. Eng.* 128(11): 1018-1029.
- [4] P. Le-Clech, V. Chen, and A. G. Fane. 2006. Fouling In Membrane Bioreactors Used In Wastewater Treatment. *J. Memb. Sci.* 284: 17-53.
- [5] Z. Yusuf, N. Abdul Wahab, and S. Sahlan. 2015. Fouling Control Strategy For Submerged Membrane Bioreactor Filtration Processes Using Aeration Airflow, Backwash, And Relaxation: A Review. *Desalin. Water Treat.* 1-13.
- [6] H. Kaneko and K. Funatsu. 2012. Visualization of Models Predicting Transmembrane Pressure Jump for Membrane Bioreactor. *Ind. Eng. Chem. Res.* 51(28): 9679-9686.
- [7] J. Busch, A. Cruse, and W. Marquardt. 2007. Run-to-run Control Of Membrane Filtration Processes. *AIChE J.* 53(9): 2316-2328.
- [8] G. Ferrero, I. Rodriguez-roda, and J. Comas. 2012. Automatic Control Systems For Submerged Membrane Bioreactors: A State-Of-The-Art Review. *Water Res.* 46: 3421-3433.
- [9] S. Curcio, V. Calabrò, and G. Iorio. 2011. Design and Tuning Of Feedback Controllers: Effects On Proteins Ultrafiltration Process Modeled By A Hybrid System. *Desalin. Water Treat.* 34: 295-303.
- [10] Á. Robles, F. Durán, M. V. Ruano, J. Ribes, A. Rosado, and J. Ferrer. 2015. Instrumentation, Control, And Automation For Submerged Anaerobic Membrane Bioreactors. *Environ. Technol.* 36(14): 37-41.
- [11] H. Monclús, J. Sipma, G. Ferrero, I. Rodriguez-roda, and J. Comas. 2010. Biological Nutrient Removal In An MBR Treating Municipal Wastewater With Special Focus On Biological Phosphorus Removal. *Bioresour. Technol.* 101: 3984-3991.
- [12] F. G. Martins. 2005. Tuning PID Controllers using the ITAE Criterion. *Int. J. Eng. Educ.* 21(5): 867-873.
- [13] N. Kamaruddin, Z. Janin, Z. Yusuf, and M. N. Taib. 2009. PID Controller Tuning For Glycerin Bleaching Process Using Well-Known Tuning Formulas - A Simulation Study. *IECON Proc. (Industrial Electron. Conf.)* 1682-1686.
- [14] Z. Yusuf, N. Abdul Wahab, and S. Sahlan. 2015. Dynamic Model Development for Submerged Membrane Filtration Process Using Recurrent Artificial Neural Network with Control Application. *1st ICRIL-International Conference on Innovation in Science and Technology*.
- [15] C. A. Smith and A. B. Corripio. 1997. *Principles and Practices of Automatic Process Control*. Second. Wiley.