



THERMAL EFFECTS OF ULTRASONICALLY EXCITED GRINDING FLUID

Jun Ishimatsu¹ and Hiromi Isobe²

¹Department of Mechanical Precision Engineering, Malaysia-Japan International Institute of Technology, Universiti Teknologi Malaysia

²Department of Mechanical Engineering, Nagaoka University of Technology, Japan
E-Mail: junishimatsu@utm.my

ABSTRACT

In this study, to reveal reason of improvements by ultrasonic excited fluid, the amount of grinding fluid is measured. The amount is increased by the ultrasonic vibrations in case of fluid supply is small and the grinding wheel speed is higher. Moreover, the temperature at the grinding point is measured by constructing a thermocouple, it was confirmed that the grinding heat is reduced by using the ultrasonic excited fluid. And the effect of removing a grinding heat is due to the effect of the grinding fluid volume increased to grinding point. And, longer chip obtained with ultrasonic excited fluid compared with ordinary fluid. It shows suppression of wear of the abrasive grains with ultrasonic excited fluid.

Keywords: ultrasonic applied grinding, grinding fluid, grinding temperature.

INTRODUCTION

Grinding is one of the machining processes used in the manufacture of high-accuracy parts. When materials which easily adhere to the grinding wheel are used, such as aluminum, stainless steel, and titanium, wheel loading must be considered, as this could have a limiting effect. Grinding is used in the manufacturing of high-accuracy parts from hard-to-cut materials. A grinding wheel has many cutters and is capable of replenishing itself. However, the condition of the grinding wheel constantly changes as grit wears and chips accumulate, loading in chip pockets. Therefore, wheel loading is one of the main factors limiting the capability of the grinding wheel. Grain distribution and grain size also play important roles in determining tool performance. This research focuses on wheel loading, which is particularly problematic with fine grit wheels, as it results in increases in grinding forces and temperature. As a consequence, the rate of abrasive wear increases and the surface integrity of the work piece deteriorate. Loading is especially likely with stainless steel, aluminum, and titanium [1].

Ultrasonic excited fluid

The fluid is provided into contact point from nozzle. Figure-1 shows basic scheme of ultrasonic excitation on grinding fluid. The effector is used to excite fluid. The effector has comb shape and the shape is optimized to be oscillated with operational frequency of BLT. These comb

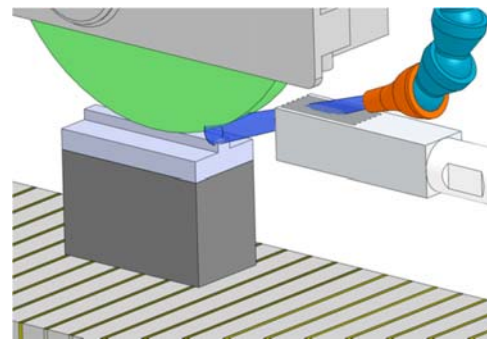

Figure-1. Scheme of ultrasonically excitation.

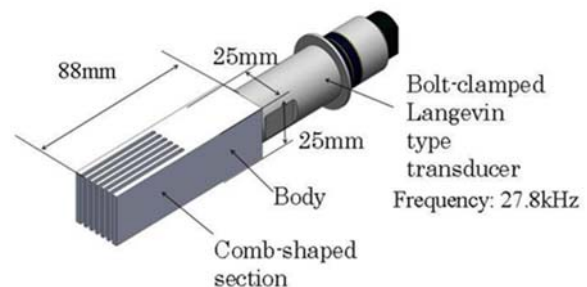

Figure-2. Ultrasonic exciter.

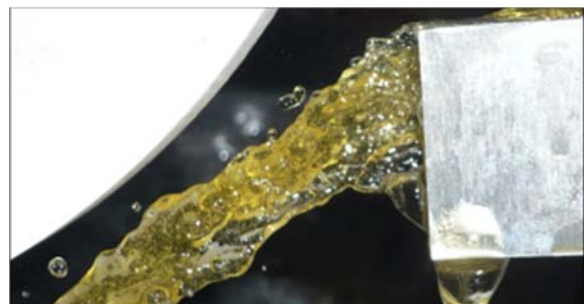

Figure-3a. Non-excited fluid.

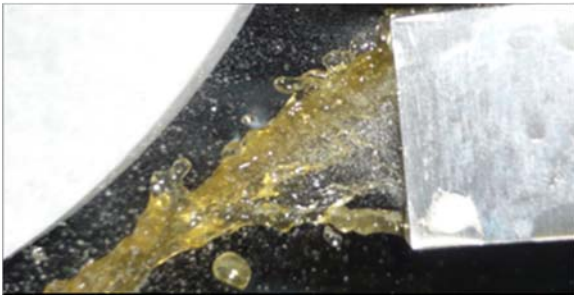

Figure-3b. Excited fluid.

teeth are inserted into grinding fluid flow between nozzle and grinding point. The effector is oscillated bottom of it by Bolted Langevin Transducer which namely BLT and comb part is vibrated as shown in Figure-2. Grinding fluid from nozzle is added an ultrasonically vibration by effector's vibration. Frequency of amplitude depends on characteristics of BLT. In this case 28 kHz of frequency is applied onto BLT.

Figure-3a shows ordinary fluid through the effector. "Ordinary" means non-excitation in this case. There is no reduction of fluid amount by inserting effector. On the other hand, Figure-3b shows ultrasonic excited fluid with 28 kHz of frequency. White colored small mist can be recognized and small bubble also can be recognized in main grinding fluid flow.

Changing amount of fluid

One of reasons for improvement of grinding performance, it is assumed that amount of provided fluid into grinding point is increased by the ultrasonically excited fluid possible to break air-layer around grinding wheel with high revolution which fly ordinary fluid apart [2]. Providing fluid through the effector has been taken by high speed camera with 1/20000 seconds of shutter speed, 6750fps of shooting speed. Figure-4a and 4b shows taken image for each case of fluid with/without excitation nearby grinding wheel which rotation speed is 1800rpm. The amount of fluid 2.4ℓ/min. In figure-4a, clearance can be recognized between flow and the wheel. It can be considered due to air-layer by high speed rotation of wheel. On the other hand, ultrasonically excited fluid can be recognized to reach surface of grinding fluid as shown in Figure-4b. It can be considered that has effect to increase the amount of provided grinding fluid into grinding point.

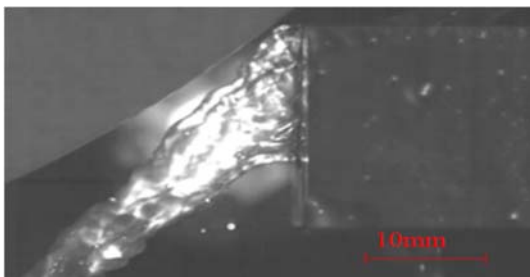

Figure-4a. Non-excited fluid.

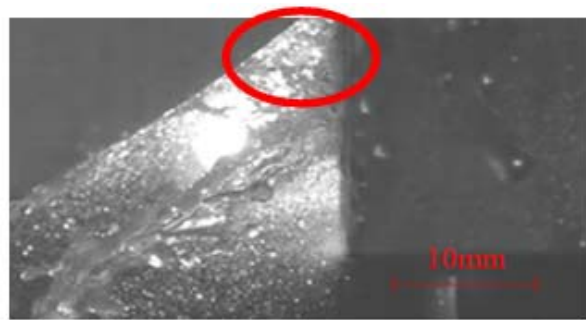

Figure-4b. Excited fluid.

As a next step, Measurement of increasing amount of grinding fluid at grinding point has been tried. The grinding fluid reach at grinding point is considered it mainly consists of which adhered on surface of rotating wheel [3]. Figure-4 shows grinding fluid corrector. It is located at under the grinding wheel during which is rotating. The point A is set under wheel and clearance with wheel is 0mm. The tube is connected point A to correct grinding fluid leach at the point. Measurement has been done with vary of conditions. Table-1 shows experimental condition and result is shown in Figure-5. Experiments

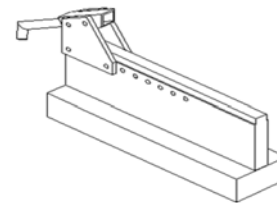

Figure-5. Grinding fluid collection equipment.

Table-1. Experimental conditions.

Grinding fluid	SS-7(synthetic JIS A2-1)
Flow rate	3.0ℓ/min, 2.0ℓ/min
Grinding wheel	WA60K8V 255x20x45mm
Rotational speed	1400-2200 rpm

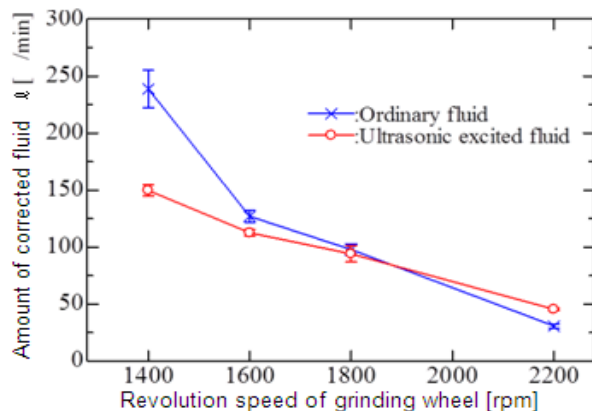

Figure-6a. Collected amount with 3.0ℓ/min.

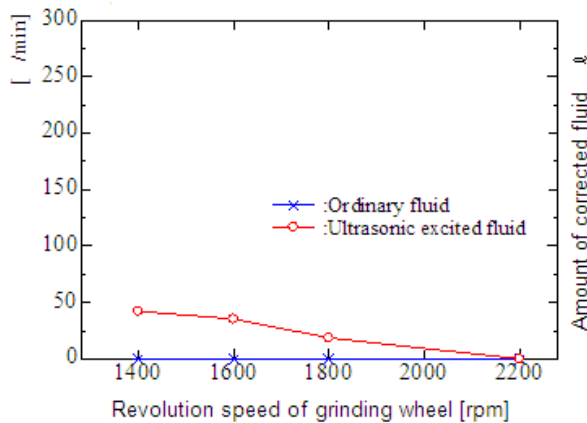

Figure-6b. Collected amount with 2.4ℓ/min.

have been done 5 times for each condition. Amount of fluid without excitation much more than fluid with excitation under condition of $Q=3.0\ell/\text{min}$ and $N=1400\text{rpm}$. Along with increasing of N , both conditions with/without excitation decrease amount of fluid which are reached to tube. With condition of $N=2200\text{rpm}$, amount of fluid with excitation higher than one without excitation. It can be considered that grinding fluid can be reach on surface of rotating wheel not related with excitation and ultrasonically excited fluid flipped from surface on contrary. On the other hands, the fluid without excitation cannot be reach surface under conditions of $Q=2.0\ell/\text{min}$ and any amount of providing fluid and can be reach surface with ultrasonically excitation. It can be considered grinding fluid is accelerated and kinetic momentum is increased by effector.

Cooling effect at grinding point

To measure cooling effect of ultrasonically excitation, the testpiece which shown in Figure-7 is used. A5052 alloy is used because of its thermal conductance. A heater is inserted into testpiece and two thermocouples (Almel-Chromel type) are set above the heater. The distance between the heater and thermocouple are 1mm and 9mm respectively. Testpiece is covered by heat insulating material except top. Grinding wheel is rotating on the top of workpiece. Temperature at two points are measured by thermocouple during heater is operated with 23W of power. Condition of fluid amount and revolution speed of wheel is shown in Table-2. 2.4ℓ/min of fluid rate is mentioned before, it is possible to reach contact point only condition with ultrasonic excitation.

Measured temperature is shown in Figure-8a and Figure-8b, Temperature obviously reduced after ultrasonic vibration is applied on fluid at both points with 2.4 ℓ/min of flow rate. On the other hands, the temperature has not changed with 3.0ℓ/min of flow rate. Thus, this reduction can be considered due to influence of ultrasonic vibration.

Temperature at grinding point

In this section, influence of ultrasonically excitation on temperature at grinding point

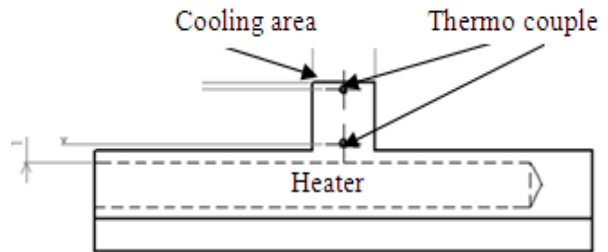

Figure-7. Workpiece for cooling effect measurement.

Table-2. Experimental conditions for cooling effect measurement.

	Rotational speed	Flow rate
Condition 1	1800 rpm	2.4 ℓ/min
Condition 2	1800 rpm	3.0 ℓ/min

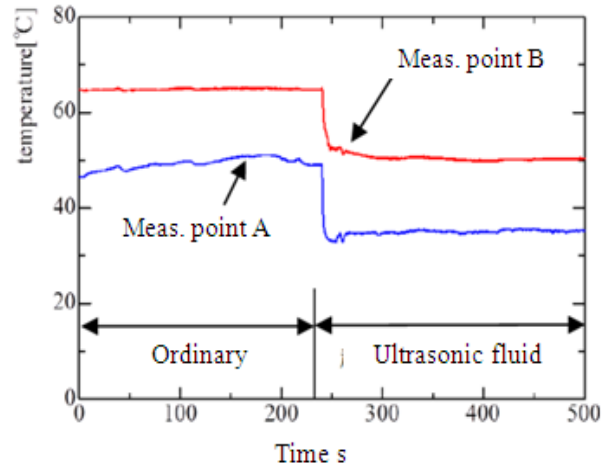

Figure-8a. Cooling effect with 2.4ℓ/min.

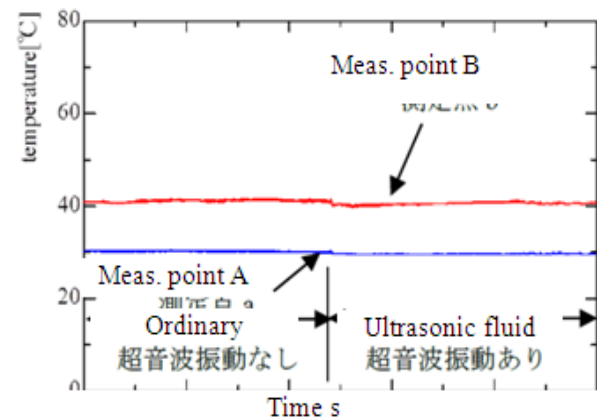

Figure-8b. Cooling effect with 3.0ℓ/min.

is investigated.

As a method to measure temperature at grinding point, several methods are proposed. In this study, embed



thermocouple method which proposed by Tsuwano [4] is used. Figure-9 shows basic scheme of embedded thermocouple workpiece. Insulating coated constantan wire is inserted into workmaterial. When the workmaterial is ground as shown in Figure-10., tip contact with the constantan wire, thermocouple is generated at this point. The thermal electromotive force which generated at thermocouple is amplified by thermocouple amplifier and recorded. Figure-11 shows sample of measured data from the experimental setup. Several waves in section A express temperature changed by grinding namely grain temperature. Due to be ground by multiple numbers of abrasive grains, temperature reaches 200degree Celsius. Curve BO is calculated based on bottom of wave increase temperature along grinding, after point O temperature is to be decreased, because point O expresses end of grinding. This curve BO corresponds to grinding point temperature, express transition of temperature along with grinding.

When work material is ground, abrasive grain heat estimated by friction and shear and distributed into grain, tip and material. Distributed heat is cooled down by grinding fluid and heat which left to be grinding point temperature. To determine grinding point temperature,

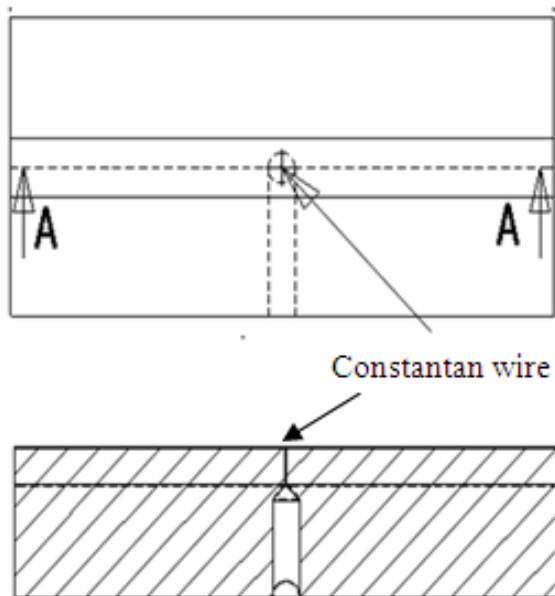

Figure-9. Embedded thermocouple workpiece.

extract bottom of waveform which obtained from

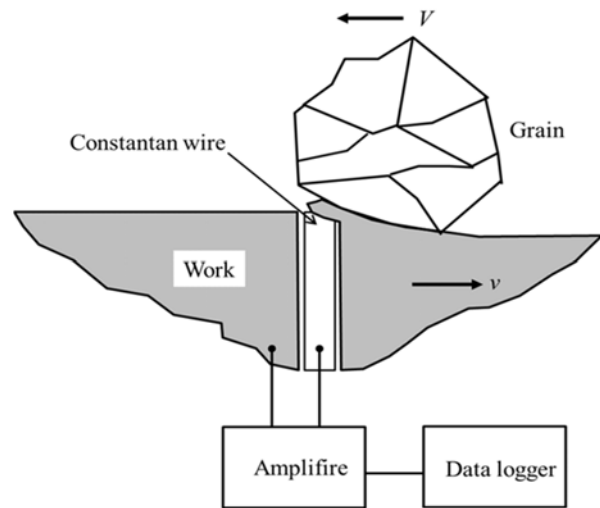

Figure-10. Scheme of embedded thermocouple.

experiment. After extraction, obtained approximation curve by least square method. Figure-12 shows obtained temperature after 512mm³ ground. Comparing both condition, Temperature with ordinary fluid which is

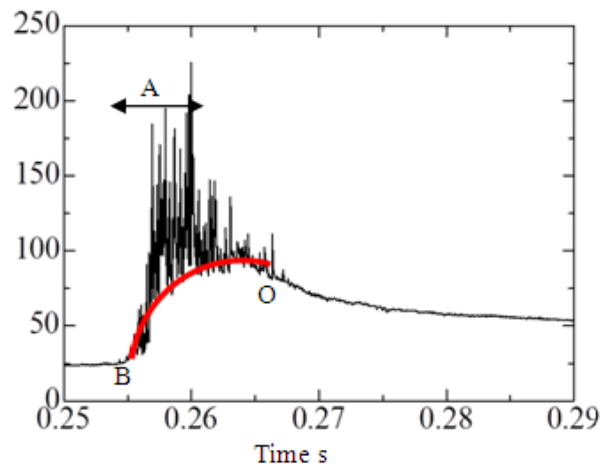
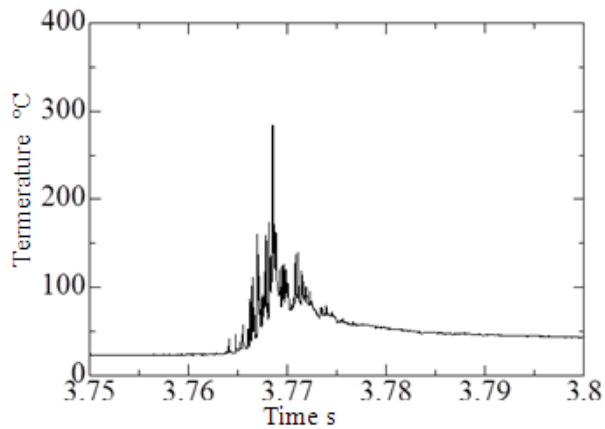

Figure-11. Example of temperature waveform.

shown in Figure-12(b) higher than temperature with ultrasonically excitation which is shown in Figure-12(a). It can be considered ultrasonically excitation possible to suppress increase temperature. Figure-13 shows transaction of temperature along with stock removal.

CONCLUSIONS

This paper has reported on an investigation of Amount of fluid, thermal conductivity of ground material and temperature at grinding point. In summary, obtained these



(a) Ultrasonic excited fluid

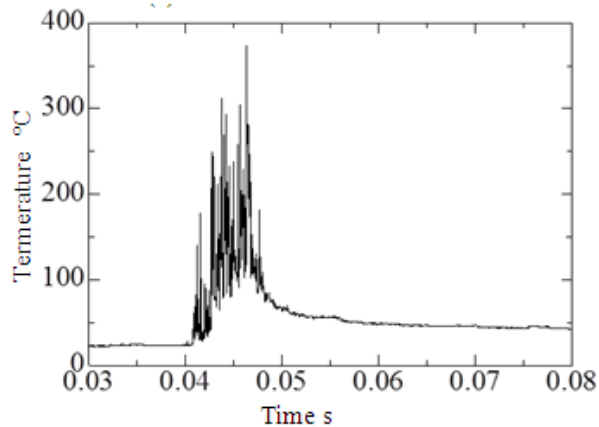

(b) Ordinary fluid

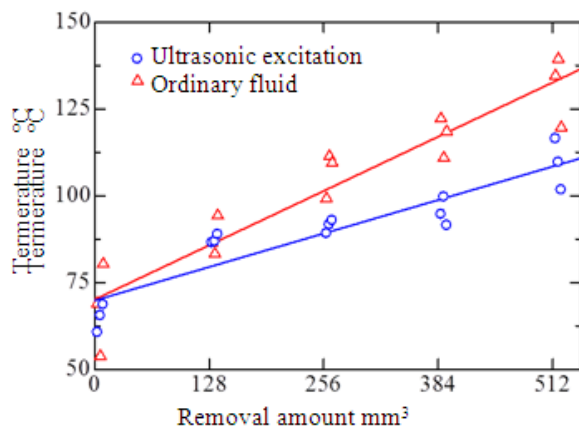
Figure-12. Obtained temperature after removal of 512mm³.**Figure-13.** Variation of temperature.

result from experimentally:

- 1) Ultrasonically excitation possible to increase amount of grinding fluid which provided into grinding point

under condition that providing amount is small and grinding speed is high.

- 2) Ultrasonically excitation is effective to increase thermal conductivity from inside to outside of material. In case of xx material thermal conductivity is 9884.1[W/m²K] with conventional fluid and 15984.0(W/m²K).
- 3) Ultrasonically excited fluid is effective to decrease temperature at grinding point.

REFERENCES

- [1] Jun Ishimatsu, Hiromi Isobe and Keisuke Hara. 2012. Experimental Verification of Effect of Grinding Fluid, Key Engineering Materials. 523-524 pp. 197-202.
- [2] Jun Ishimatsu, Atsushi Iwaita, and Hiromi Isobe. 2014. Grinding a Hard-to-Grind Materials with Ultrasonic-Assisted Fluid International Journal of Automation Technology. Vol. 8 No. 3, pp. 478-483.
- [3] Toshio Akiyama, Junji Shibata, Sakae Yonets. 1985. Study on Effective Delivery Conditions of Grinding fluid, Japan Precision Engineering. 51(7), pp. 1453-1459(In Japanese).
- [4] Tetsuo Matsuo, Yasuo Uchikawa, Heiji, Yasui, Hideo Tsuwa. 1971. Surface Grinding of Carbon Steel at -196 to +600: Effects of Workpiece Temperature on Grindability of Steels (1st Report), Japan Precision Engineering. 37(434) pp. 190-195.