

EFFECT OF CHANNEL SPACING ON THE SIGNAL QUALITY FOR A BI-DIRECTIONAL TWDM PON

Shahid Ur Rehman^{a,b}, Sevia M. Idrus^{a*}, Raja Zahillah Radzi^c, Mohd Shahrill Salleh^c, Rizwan Aslam Butt^b

^aLightwave Communication Research Group, Faculty of Electrical Engineering, University Teknologi Malaysia, Johor Bahru, Malaysia

^bNED University of Engineering & Technology, Department of Electronic Engineering, Karachi, Pakistan

^cTelecom Malaysia R&D Sdn Bhd, Selangor, Malaysia

Article history

Received

15 August 2015

Received in revised form

15 November 2015

Accepted

30 December 2015

*Corresponding author

sevia@fke.utm.my

Graphical abstract

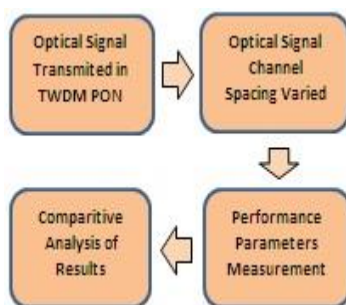

Abstract

As the demand for broadband services increase coupled with the introduction of new services like online interactive gaming, high definition video TV, video on demand etc., the ability to support higher data rates and efficient utilization of the deployed network is necessary. This largely depends on the capacity and quality of the access networks. Currently deployed Passive Optical Networks (PON) like GPON and EPON will not be able to meet the growing demand in the future. Although both of these PONs have evolved to their respective 10G versions called XG-PON and 10G-EPON, they will eventually reach the limit of their capacity. This has paved the way for the next evolution of PON named as Next Generation PON Stage-2 (NG-PON2). NG-PON2 has the advantage of a much larger bandwidth and scalability by using a combination of Time and Wavelength Division Multiplexing known as TWDM PON. In this paper we have investigated the effect of varying channel spacing (50GHz, 100GHz and 200GHz) on the quality of a Bi-directional TWDM PON signal. The best results were obtained with the widest channel spacing of 200GHz (1.6nm).

Keywords: PON, GPON, NG-PON2, TWDM, bi-directional

Abstrak

Oleh sebab permintaan untuk perkhidmatan jalur lebar semakin bertambah dengan kemunculan perkhidmatan baru seperti permainan dalam talian interaktif, video TV berdefinisi tinggi, video atas permintaan dan lain-lain, keupayaan untuk menyokong kadar data yang lebih tinggi dan kecekapan dalam penggunaan rangkaian adalah penting. Ini banyak bergantung kepada kapasiti dan kualiti rangkaian akses. Rangkaian optik pasif (PON) yang digunakan sekarang seperti GPON dan EPON tidak akan dapat memenuhi permintaan yang semakin meningkat pada masa hadapan. Walaupun kedua-dua PON ini telah berkembang kepada versi 10G masing-masing yang dipanggil XG-PON dan 10G-EPON, mereka pun akan mencapai had keupayaan mereka pada akhirnya. Ini telah membuka jalan kepada evolusi PON seterusnya yang dinamakan sebagai Next Generation PON Tahap-2 (NG-PON2). NG-PON2 mempunyai kelebihan jalur lebar dan kebolehskalaan yang lebih besar dengan menggunakan penggabungan antara pemultipleksan bahagian masa dan panjang gelombang yang dikenali sebagai TWDM PON. Dalam kertas ini, kami telah menyasat kesan perubahan jarak saluran (50GHz, 100GHz dan 200GHz) kepada kualiti isyarat dwiarah TWDM PON. Keputusan terbaik telah diperolehi dengan jarak saluran terluas yang bernilai 200GHz (1.6 nm).

Kata kunci: PON, GPON, NG-PON2, TWDM, Dwiarah

© 2016 Penerbit UTM Press. All rights reserved

1.0 INTRODUCTION

Passive Optical Networks (PON) have evolved from early APON/BPON (ATM/Broadband PON) [1, 2] to GPON (Gigabit-PON) [3] and XG-PON (Next Generation GPON) [4] with data rates progressively increasing from 155Mbps to 10Gbps for both Upstream (US) and Downstream (DS) direction. Similarly the split ratios and passive reach supported by these different generations of PON's have increased from the initial requirement of 1:16/32 to present split of 1:64 and beyond with a maximum reach of 20km. But keeping in view the continuous growth in the demand of higher data rates due to the types of broadband services offered by the Telco's and other service providers for both fixed and mobile subscribers, there is still need of increasing the data rates, split ratios and reach of the PON's to provide all types of data intensive services to a larger number of users at greater distances than currently supported by the different legacy PON deployments. Keeping in view of the above stated requirements from next generation of PON, NG-PON2 was proposed as the next evolution of PON by the Full Service Access Network (FSAN).

The candidate technology option for NG-PON2 included Time Division Multiplexed PON (TDM-PON) [5], Wavelength Division Multiplexed PON (WDM-PON) [6], Hybrid Time and Wavelength Division Multiplexed PON (TWDM-PON) [7], Orthogonal Frequency Division Multiplexed PON (OFDM-PON) [8] and Code Division Multiplexed PON (CDM-PON) [9]. Finally Hybrid TWDM-PON was selected as the NG-PON2 technology in 2012 by FSAN due to a combination of technical and economic considerations.

2.0 TWDM PON (NG-PON2)

Salient features which led to the choice of TWDM-PON were ability to co-exist with legacy PON without re-engineering the Optical Distribution Network (ODN), relative complexity of the implementation technology and availability of components, modular upgrade ability of the system to support pay as you grow (PAYG) concept and support for both residential users (generally asymmetric data rates for DS and US) and business/backhaul users (generally symmetric data rates for DS and US). It also supports point to point WDM overlay channels for high capacity service on the same PON ODN [10].

The general requirements for NG-PON2 as laid out in ITU-T Recommendation (G.989.1, NG-PON2) are: (1) Number of Channels (4-8 Channel Pairs, each pair having one DS and US channel), (2) Data Rates per channel (10Gbps DS/US DS, 10Gbps DS/2.5 Gbps US, and 2.5 Gbps DS/US), (3) Passive reach of 40km, (4) Split ratio of 1:256. A comprehensive review of the NG-PON2 TWDM PON can be found in the literature covering the technology, standards, architecture and key components [10, 12].

As there are now more than one channel available for both US and DS transmission therefore its important to investigate the impact of channel spacing as specified in ITU-T Recommendation [13], will have over the performance of a PON bi-directional link. In this paper a bi-directional hybrid TWDM PON is considered to analyze the impact channel spacing will have over its transmission performance using Optisystem 13.0 [19] software tool. Optisystem has an advanced simulation environment to design and test a variety of optical systems and create custom optical components for academic research and communication engineering applications. In literature the performance parameters are mostly investigated for WDM PON [16, 17] and for TWDM PON [18] but we have not found any paper dealing specifically with the impact of channel spacing variation on the performance of the received signal for a bi-directional TWDM PON.

3.0 SIMULATION SETUP

The simulation setup uses four wavelengths pairs for downstream and upstream channels respectively with adjacent wavelength (frequency) spacing of 0.4nm (50GHz), 0.8nm (100GHz) and 1.6nm (200GHz) which complies with the ITU-T recommendation for the Physical Layer of NG-PON2 which specifies the minimum and maximum channel spacing as 50GHz and 200GHz respectively. The wavelength plan for the simulation is shown in Table 1, the wavelength plan is selected keeping in view the legacy PON and RF video coexistence with TWDM PON [14].

The symmetric 2.5Gbps TWDM PON is implemented without any amplification and Forward Error Correction (FEC) scheme at Optical Line Terminal (OLT) side for a bi-directional fiber span of 40km. ODN Class E1 is assumed for the purpose of simulation [15]. The parameters used for performance evaluation are Bit Error Rate (BER) and Quality Factor (Q-Factor). The other simulation setup parameters for the TWDM PON network are listed in Table 2.

The simulation setup is shown in Figure 1. The setup shows the splitters as a combined block (two-stage splitting was utilized in simulation). Each wavelength pair serves a total of 16 users by passively splitting the signal at Remote Node (RN). The OLT has four pair of ports generating and receiving four Downstream and Upstream signals respectively. Using a cyclic AWG Multiplexer/De-Multiplexer the same optical fiber is used for bidirectional traffic between OLT and Optical Network Units (ONU's). The ONU's receive the desired wavelength using a tunable filter for downstream signal. The upstream signal can also be tuned using a tunable source to any of the required upstream wavelengths.

Table 1 Wavelength Plan

Channel No.	Wavelength (0.4nm spacing)	Wavelength (0.8nm spacing)	Wavelength (1.6nm spacing)
DS1	1596	1596	1596
DS2	1596.4	1596.8	1597.6
DS3	1596.8	1597.6	1599.2
DS4	1597.2	1598.4	1600.8
US1	1528	1528	1528
US2	1528.4	1528.8	1529.6
US3	1528.8	1529.6	1531.2
US4	1529.2	1530.4	1532.8

Table 2 TWDM PON Parameters

Component	Parameter	Value
PRBS Generator	Bit Rate	2.5Gbps
Light Source	Transmitter Power (ONU/OLT)	+5dBm/ +7dBm
Pulse Generator	Line Coding	NRZ
MZM-External	Extinction Ratio	≥ 12dB
AWG	Bandwidth	10GHz
	Insertion Loss	1dB
Optical Fiber	Span	40Km
	Loss coefficient	0.2dB/Km
Splitter 1x4	Splitter +Insertion Loss	7dB
Splitter 1x16	Splitter +Insertion Loss	15dB
Photodetector	Responsivity	1A/W
	Dark Current	10nA
	Sensitivity	-30 dBm
Global Parameter	Bit Sequence	128 bits

3.0 RESULTS AND DISCUSSION

The BER and Q-Factor are observed at the respective receivers in the OLT and ONU's for both the upstream and downstream signals at wavelengths spaced by the plan provided in Table 1. The Results are plotted for each set of wavelengths against BER at ONU and OLT receiver respectively. Q-Factor is also plotted using a similar setup as described above for BER. Figure 2 and 3 shows the plot of BER and Q-Factor at ONU receiver side against the four downstream wavelengths for the set of 50GHz, 100GHz and 200GHz channel spacing each.

The graphs obtained for the BER and Q-Factor values for channel spacing of 1.6nm (200GHz) are clearly lower and higher than both 0.4 and 0.8nm channel spacing respectively. The more spacing between adjacent channels result in less crosstalk and better BER and Q-Factor values are obtained. Also the variations for the largest channel spacing are much smoother than the other two lower values of channel spacing. The three curves in each plot follow the same pattern of variations but only differing in the value of change with respect to the next adjacent channel.

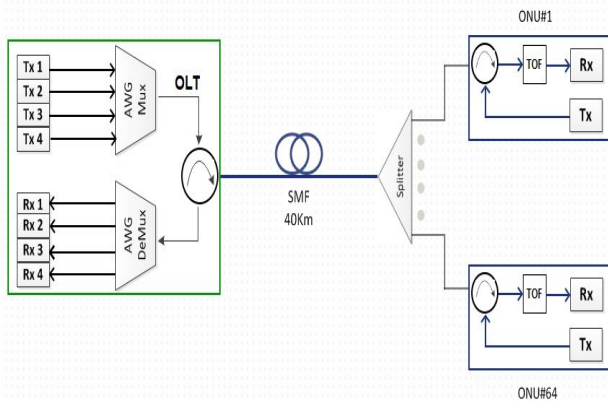

Figure 1 TWDM PON Simulation Setup

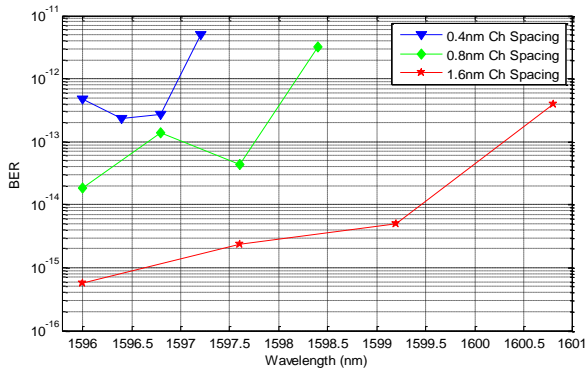

Figure 2 Wavelength Vs BER (ONU Receive - Downstream)

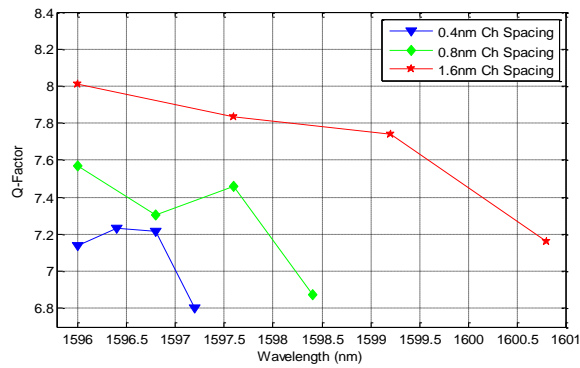

Figure 3 Wavelength Vs Q-Factor (ONU Receive- DS)

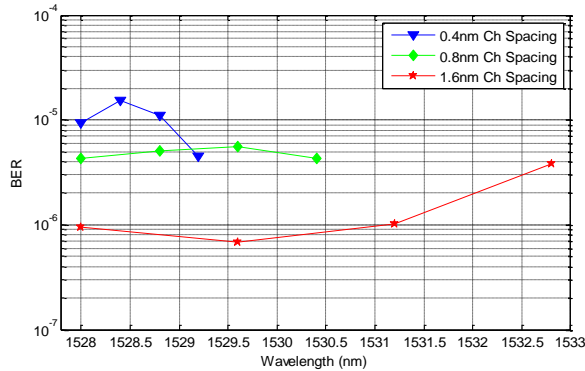

Figure 4 Wavelength Vs BER (OLT Receive - Upstream)

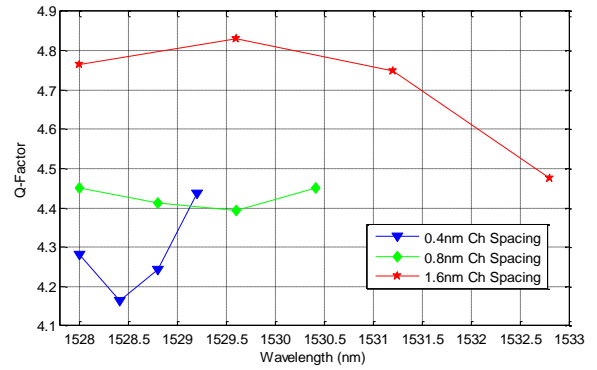

Figure 5 Wavelength Vs Q-Factor (OLT Receive - US)

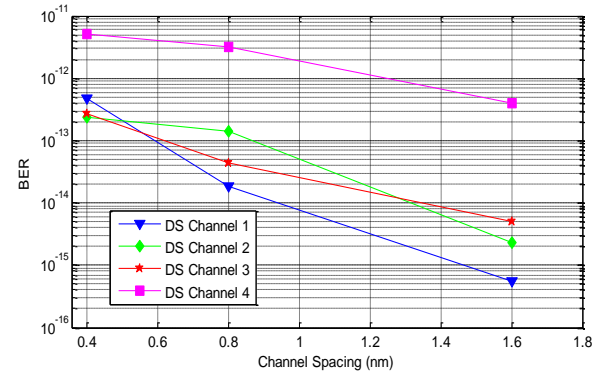

Figure 6 BER as a function of Channel Spacing-DS

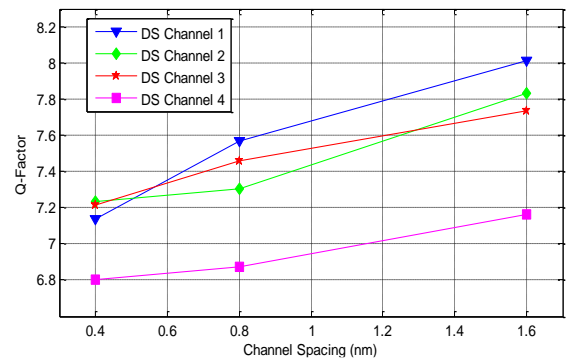

Figure 7 Q-Factor as a function of Channel Spacing-DS

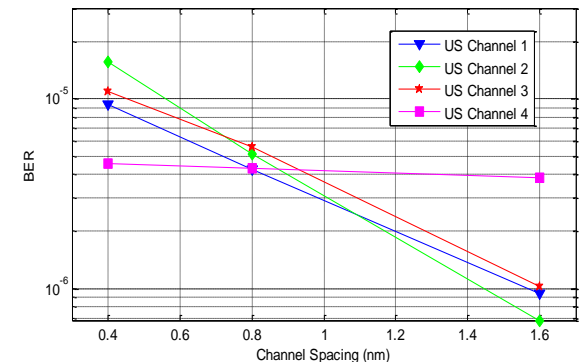

Figure 8 BER as a function of Channel Spacing-US

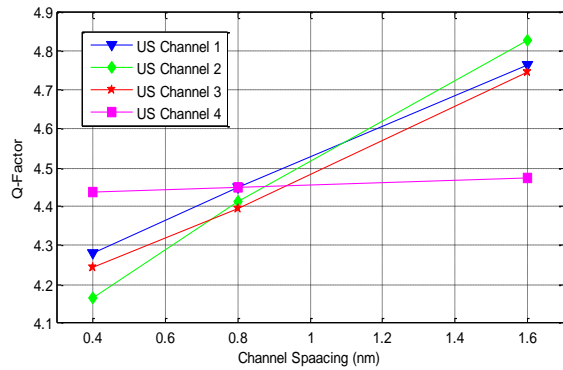

Figure 9 Q-Factor as a function of Channel Spacing-US

Similarly Figure 4 and 5 shows the plot of BER and Q-Factor at OLT receiver side against the upstream wavelengths for the three set of channel spacing. Exhibiting the same trend as was observed for downstream channels the upstream wavelengths with the widest channel spacing (1.6nm) showing better values for both performance parameters of BER and Q-Factor. The variations in the values for the BER and Q-Factor is steadier for the 0.8nm and 1.6nm case than for the 0.4nm channel spacing.

The difference in the performance parameters (BER and Q-Factor) for both Downstream and Upstream channels even for the same channel spacing wavelengths is due to the propagation characteristics variation for the respective wavelengths and to the difference in response of each wavelength to the fiber impairments and non-linearities.

Figure 6 and 7 shows the variation of BER and Q-Factor as a function of Channel Spacing for Downstream signals respectively. From the graph obtained it is clear that as the Channel Spacing among adjacent WDM Channels is increased the BER decreases for all four downstream wavelengths which is the expected result as the impact of crosstalk between neighboring channels decreases, resulting in improved performance for the received signal parameters. Similarly an increase of Q-factor is observed as the Channel spacing changes from minimum to maximum for downstream signal. Channel no.4 (DS-4) has the least amount of variation when compared with other channels of the downstream wavelength plan.

Similarly Figure 8 and 9 shows the variation of BER and Q-Factor as a function of Channel Spacing (Upstream signals) respectively. Again the graphs indicate that the larger channel spacing of 1.6nm results in improvement in both BER and Q-Factor. The first three channels show the almost similar pattern of variation in BER and Q-Factor while the fourth channel almost remains the same for the all the three cases of channel spacing. Channel 1, 2 and 3 have almost linear relationship between Channel spacing, BER and Q-Factor while channel 4 shows very small increase in the performance parameters with increasing channel spacing.

4.0 CONCLUSION AND FUTURE WORK

In this paper the effect of channel spacing on the quality of signal was presented by using the performance parameters of BER and Q-Factor. The 1.6nm (200GHz) channel spacing downstream signal at channel DS1 achieved the lowest BER (5.61681E-16) and highest Q-Factor (8.01252). For upstream signal, again the 1.6nm spacing channel no US2 registered the lowest BER (6.82307E-7) and highest value of Q-Factor (4.82972) for a total bi-directional PON link of 40km length. The results indicate that the adjacent channels when separated by the maximum channel spacing have the least amount of crosstalk which results in superior performance recorded for the BER and Q-Factor of individual channels at the respective receivers. These results are obtained without using any FEC scheme at the receivers. The work can be extended to evaluate the signal performance for more than four channels, increased line rate and split ratio under different component parameters to find the optimum combination of signal quality and cost effective utilization of optical components.

Acknowledgement

This work was supported by Ministry of Science, Technology and Innovation (MOSTI) and the administration of Universiti Teknologi Malaysia (UTM) for the project financial support through Escience Fund vote number 4S087. The authors acknowledge the NED University of Engineering & Technology for the financial support for PhD Scholarship to the author 1.

References

- [1] Keiser, G. 2006. *FTTX Concepts and Applications*. New Jersey: John Wiley & Sons.
- [2] Shumate, P. W. 2008. Fiber to the Home: 1977-2007. *Journal of Lightwave Technology*. 26(9): 1093-1103.
- [3] Cale, I., Salihovic, A., and Ivkovic, M. 2007. Gigabit Passive Optical Network-GPON. *29th International Conference on Information Technology Interfaces*. 679-684.
- [4] Effenberger, F. J. 2011. The XG-PON System: Cost Effective 10Gbps Access. *Journal of Lightwave Technology*. 29(4): 403-409.
- [5] Veen, D. V., Suvakovic, D., Chow, H., Houtsma, V., Harstead, E., Winzer, P. J. and Vetter, P. 2012. Options for TDM PON beyond 10G. *Access Networks and In house Communications*. AW2A.1.
- [6] Park, S. J., Lee, C. H., Jeong, K. T. and Park, H. J. 2004. Fiber to the Home Services based on Wavelength Division Multiplexing. *Journal of Lightwave Technology*. 22(11): 2582-2591.
- [7] Poehlmann, W. and Pfeiffer, T. 2011. Demonstration of Wavelength Set Division Multiplexing For A Cost Effective PON with upto 80Gb/s Upstream Bandwidth. *37th ECOC*. 1-3.
- [8] Cvijetic, N. 2012. OFDM for Next Generation Optical Access Networks. *Journal of Lightwave Technology*. 30(4): 384-398.

- [9] Kamijoh, T., Kashima, M., Tamai, H., Sarashina, M., Iwamura, H., Gupta, G. C. 2009. CDM Technologies for next Generation Optical Access Network. *OFC/NFOEC*. 1-3.
- [10] Nasset, D. 2015. NG-PON2 Technology and Standards. *Journal of Lightwave Technology*. 33(5):1136-1143.
- [11] ITU-T Recommendation G.989.1. 2013. *40-Gigabit-Capable Passive Optical Networks (NG-PON2): General Requirements*.
- [12] Bindhaq, S., Supa'at, A. S. M., Zulkifli, N., Mohammad, A. B., Shaddad, R. Q., Elmagzoub, M. A., Faisal, A. 2015. *Optical Switching and Networking*. 15(2015): 53-66.
- [13] ITU-T Recommendation G.694.1. 2012. *Spectral Grids for WDM Applications: DWDM Frequency Grids*.
- [14] ITU-T Recommendation G.984.5. 2014. *Gigabit-capable Passive Optical Networks (GPON): Enhancement Band*.
- [15] ITU-T Recommendation G.989.2. 2014. *40-Gigabit-capable Passive Optical Networks 2 (NG-PON2): Physical Media Dependent Layer Specification*.
- [16] Kaur, A. and Kaur, R. 2013. Design and Performance Evaluation of 20 GB/s Bidirectional DWDM Passive Optical Network Based on Array Waveguide Gratings. *IJARECE*. 2(9): 764-768.
- [17] Villarreal, G. D., Cardenas, A. M. and Botia, J. F. 2013. Performance of WDM PON System based on Optical Frequency Comb Generation. *IEEE Colombian Conference on Communications and Computing*. 1-6.
- [18] Elmagzoub, M. A., Mohammad, A. B., Shaddad, R. Q. and Al-Gailani, S. A. 2014. *International Journal of Light & Electron Optics*. 125(20): 6194-6197.
- [19] Optic System Software. Optiwave. 2014 <http://optiwave.com/category/products/system-and-amplifier-design/optisystem>.