

**VOT 79018**

**DESIGN AND DEVELOPMENT OF FRACTAL ANTENNA  
FOR ULTRA HIGH FREQUENCY BAND APPLICATION**

**(MEREKABENTUK DAN MEMBANGUNKAN ANTENA  
FRACTAL UNTUK APLIKASI JALUR ULTRA  
FREKUENSI TINGGI)**

**MOHAMAD KAMAL A. RAHIM**

**RESEARCH VOTE NO:  
79018**

**Jabatan Kejuruteraan Perhubungan Radio  
Fakulti Kejuruteraan Elektrik  
Universiti Teknologi Malaysia**

**2008**

## UNIVERSITI TEKNOLOGI MALAYSIA

**BORANG PENGESAHAN  
LAPORAN AKHIR PENYELIDIKAN**

JUDUL: DESIGN AND DEVELOPMENT OF FRACTAL ANTENNA  
FOR UHF BAND APPLICATION

Saya MOHAMAD KAMAL A. RAHIM  
(HURUF BESAR)

mengaku membenarkan **Laporan Akhir Penyelidikan** ini disimpan di Perpustakaan Universiti Teknologi Malaysia dengan syarat-syarat kegunaan seperti berikut:

1. Tesis adalah hak milik Universiti Teknologi Malaysia.
2. Perpustakaan Universiti Teknologi Malaysia dibenarkan membuat salinan untuk tujuan pengajian sahaja.
3. Perpustakaan dibenarkan membuat salinan tesis ini sebagai bahan pertukaran antara institusi pengajian tinggi.
4. \*Sila tandakan ( ✓ )

SULIT

(Mengandungi maklumat yang berdarjah keselamatan atau kepentingan Malaysia seperti yang termaktub di dalam AKTA RAHSIA RASMI 1972)

TERHAD

(Mengandungi maklumat TERHAD yang telah ditentukan oleh organisasi/badan di mana penyelidikan dijalankan)

TIDAK TERHAD

Disahkan oleh,



( TANDATANGAN KETUA PENYELIDIK )

Prof Madya Dr Mohamad Kamal A Rahim  
Nama & Cop Ketua Penyelidik

Tarikh : 8 Ogos 2008

CATATAN: \* Jika tesis ini SULIT atau TERHAD, sila lampirkan surat daripada pihak berkuasa/organisasi berkenaan dengan menyatakan sekali sebab dan tempoh tesis ini perlu dikelaskan sebagai SULIT atau TERHAD

**VOT 79018**

**DESIGN AND DEVELOPMENT OF FRACTAL ANTENNA  
FOR ULTRA HIGH FREQUENCY BAND APPLICATION**

**(MEREKABENTUK DAN MEMBANGUNKAN ANTENA  
FRACTAL UNTUK APLIKASI JALUR ULTRA  
FREKUENSI TINGGI)**

**MOHAMAD KAMAL A. RAHIM**

**RESEARCH VOTE NO:  
79018**

**Jabatan Kejuruteraan Perhubungan Radio  
Fakulti Kejuruteraan Elektrik  
Universiti Teknologi Malaysia**

**2008**

**DECLARATION**

I declare that this report entitled “Design and Development of Fractal Antenna for Ultra High Frequency (UHF) Band Application” is the result of my own research except as cited in the references.

Signature :  .....

Name of Supervisor : ASSOC. PROF. DR. MOHAMAD KAMAL B.  
ABD. RAHIM

Date : OGOS 2008

## ACKNOWLEDGEMENT

In finishing this project, I was in contact with many people, researchers, academicians, and practitioners. They have contributed towards my understanding and thoughts. In particular, I am also very thankful to Mr. Thelaha, a Ph.D. Student of UTM and all my fellow researchers for their helps. Without their continued support and interest, this project would not have been the same as presented here.

I am also indebted to Universiti Teknologi Malaysia (UTM) for funding my research. Besides, librarians at UTM also deserve special thanks for their assistance in supplying the relevant literatures.

My fellow researchers should also be recognized for their support. My sincere appreciation also extends to all my colleagues and others who have provided assistance at various occasions. Their views and tips are useful indeed. Unfortunately, it is not possible to list all of them in this limited space. Last but not least, I am truly grateful for having such a supportive family members.

## DESIGN AND DEVELOPMENT OF FRACTAL ANTENNA FOR ULTRA HIGH FREQUENCY BAND APPLICATION

*(Keywords: Fractal antenna, Ultra High Frequency)*

The Ultra High Frequency (UHF) band has long been used for voice, data and video communication. The lower frequency band of the UHF which is the 470 –890 MHz is used for terrestrial TV broadcast. The conventional UHF antennas for receiving TV signals are quite large and directional. It would be better to have a compact and omnidirectional antenna that can be easily fabricated, especially for portable devices such as portable televisions. Koch curve fractal structure is one of the fractal geometries used in antenna designs. One of the benefits of using fractals in the design of antenna structure includes miniaturization. The dipole antenna is one of the omnidirectional that can be easily designed. The planar type of antenna is one of the easiest to fabricate. This project report describes the design of the planar fractal antenna for the uhf band using the Koch curve structure. Different shapes of antenna using the truncated ground plane have been designed and simulated to investigate which is the one that gives the best performance. The simulation process was done using the Agilent ADS software and Computer Simulation Technology CST. The antenna has been fabricated on the FR4 microstrip board with  $\epsilon_r = 4.7$  and thickness of 1.6 mm using the photolithography and wet etching technique. The simulation result shows that the Koch curve can be used to minimize the length of the dipole. It also shows that the folded dipole configuration together with using Koch curve can increase bandwidth and minimize the length of the antenna. The fabricated antenna have been test and measured in term of radiation pattern and return loss and it can be used at a certain band of frequencies.

### **Key Researcher:**

Assoc. Prof. Dr. Mohammad Kamal A. Rahim (Head)

Mr Nazri A. Karim

Mr. Thelaha Masri

Mr Huda A. Majid

Mr Osman Ayop

e-mail : mkamal@fke.utm.my

Tel No. : 07-5536088

Vote No. : 79018

**MEREKABENTUK DAN MEMBANGUNKAN ANTENA FRACTAL UNTUK  
APLIKASI JALUR ULTRA FREKUENSI TINGGI**  
(Kata kunci: Antena Fractal, Ultra Frekuensi Tinggi)

Jalur Ultra Frekuensi Tinggi (UHF) telah lama digunakan untuk komunikasi video, suara, dan data. Frekuensi jalur rendah daripada UHF iaitu diantara 470–890 MHz digunakan untuk penyiaran televisyen. Antena UHF yang sekarang banyak digunakan untuk penerimaan isyarat televisyen adalah agak besar dan terarah. Adalah lebih baik sekiranya dibuat sebuah antena yang lebih kecil dan semua arah yang dapat dengan mudah dibuat, terutamanya untuk alatan mudah alih seperti televisyen mudah alih. Struktur *fractal* lengkungan *Koch* adalah salah satu bentuk yang digunakan untuk merekabentuk antena. Salah satu kelebihan menggunakan *fractal* adalah mengecilkan saiz struktur. Antena *dipole* adalah salah satu antena semua arah yang mudah untuk direkabentuk. Antena jenis *planar* adalah salah satu bentuk antena yang paling mudah difabrikasi. Projek ini menerangkan tentang rekabentuk antena *planar fractal* untuk jalur UHF menggunakan struktur *Koch*. Pelbagai bentuk antena menggunakan satah bumi terpenggal telah direkabentuk dan disimulasi untuk mengkaji prestasi yang paling bagus. Proses simulasi telah dilakukan menggunakan perisian Agilent ADS. Antena difabrikasi menggunakan papan FR4 dengan  $\epsilon_r = 4.7$  dengan ketebalan 1.6 mm menggunakan teknik *photolithography* dan punaran basahan. Hasil simulasi menunjukkan bahawa panjang antena *dipole* boleh dikurangkan menggunakan lengkungan *Koch*. Ia juga menunjukkan konfigurasi lipatan *dipole* bersama lengkungan *Koch* boleh meningkatkan lebar jalur dan mengurangkan panjang antena. Antena yang telah difabrikasi diuji dari segi bentuk penyinaran dan kehilangan balikan dan boleh digunakan pada sesetengah jalur frekuensi.

**Penyelidik:**

Assoc. Prof. Dr. Mohammad Kamal A. Rahim (Head)

Mr Nazri A. Karim

Mr. Thelaha Masri

Mr Huda A. Majid

Mr Osman Ayop

e-mail : mkamal@fke.utm.my

Tel No. : 07-5536088

Vote No. : 79018

## TABLE OF CONTENT

| CHAPTER  | TITLE  | PAGE       |
|----------|--|------------|
|          | <b>TITLE</b>                                       | <b>i</b>   |
|          | <b>DECLARATION</b>                                 | <b>ii</b>  |
|          | <b>ACKNOWLEDGMENT</b>                              | <b>iii</b> |
|          | <b>ABSTRACT (ENGLISH)</b>                          | <b>iv</b>  |
|          | <b>ABSTRAK (BAHASA MALAYSIA)</b>                   | <b>v</b>   |
|          | <b>TABLE OF CONTENTS</b>                           | <b>vi</b>  |
|          | <b>LIST OF FIGURES</b>                             | <b>ix</b>  |
|          | <b>LIST OF SYMBOLS</b>                             | <b>xi</b>  |
|          | <b>LIST OF ABBREVIATIONS</b>                       | <b>xii</b> |
| <br>     |  |            |
| <b>1</b> | <b>INTRODUCTION AND BACKGROUND<br/>OF RESEARCH</b> |            |
|          | 1.0 Introduction                                   | 1          |
|          | 1.1 Problem Statement                              | 4          |
|          | 1.2 Objective                                      | 4          |
|          | 1.2 Scope of Project                               | 5          |
|          | 1.3 Organization of Thesis                         | 5          |
|          | 1.4 Summary  | 6          |



## **2 LITERATURE REVIEW**

|       |                            |    |
|-------|----------------------------|----|
| 2.1   | Introduction               | 7  |
| 2.2   | Classification of antennas | 7  |
| 2.2.1 | Frequency and size         | 7  |
| 2.2.2 | Directivity                | 8  |
| 2.2.3 | Physical construction      | 8  |
| 2.2.4 | Application                | 8  |
| 2.3   | Antenna Properties         | 9  |
| 2.3.1 | Operating Frequency        | 9  |
| 2.3.2 | Return Loss                | 10 |
| 2.3.3 | Bandwidth                  | 10 |
| 2.3.4 | Antenna Radiation Patterns | 11 |
| 2.3.5 | Power Gain                 | 11 |
| 2.3.6 | Directivity                | 12 |
| 2.3.7 | Polarization               | 12 |
| 2.4   | TV Antenna Basics          | 13 |
| 2.5   | Dipole Antenna             | 15 |
| 2.6   | Planar Antennas            | 19 |

## **3 FRACTAL DIPOLE ANTENNA DESIGN**

|       |   |    |
|-------|---|----|
| 3.0   | Introduction  | 21 |
| 3.1   | Antenna Design Specifications                       | 21 |
| 3.2   | Design of the antenna using antenna design software | 23 |
| 3.3   | Simulation Using Computer Simulation Technology     | 27 |
| 3.3.1 | SMA and Waveguide Port Connector                    | 28 |
| 3.3.2 | Fundamental Quasi-TEM mode                          | 29 |
| 3.4   | Simulated Single Koch Dipole                        | 31 |
| 3.5   | Fabrication of the antenna                          | 33 |
| 3.6   | Measurements of the Antenna                         | 37 |

|          |       |   |    |
|----------|-------|---|----|
|          | 3.6.1 | Input Return Loss Measurement           | 37 |
|          | 3.6.2 | Radiation Pattern Measurement           | 38 |
|          | 3.7   | Summary                                 | 39 |
| <b>4</b> |       | <b>RESULTS &amp; DISCUSSIONS</b>        |    |
|          | 4.0   | Introduction                            | 40 |
|          | 4.1   | Antenna Simulation Results              | 40 |
|          | 4.1.1 | Standard straight line dipole           | 40 |
|          | 4.1.2 | 3 <sup>rd</sup> order Koch curve dipole | 42 |
|          | 4.2   | Antenna Measurement Results             | 46 |
|          | 4.2.1 | Return Loss Measurement Results         | 46 |
|          | 4.2.2 | Radiation Pattern Measurement Results   | 49 |
|          | 4.3   | Summary                                 | 55 |
| <b>5</b> |       | <b>CONCLUSION</b>                       |    |
|          | 5.0   | Conclusion                              | 56 |
|          | 5.1   | Proposed Future Work                    | 57 |
|          |       | <b>REFERENCES</b>                       | 58 |
|          |       | <b>APPENDIX A</b>                       | 61 |
|          |       | <b>APPENDIX B</b>                       | 62 |
|          |       | <b>APPENDIX C</b>                       | 63 |

## LIST OF FIGURES

| FIGURE NO. | TITLE  | PAGE |
|------------|--|------|
| 2.1        | Radiation pattern of an antenna  | 11   |
| 2.2        | Current (a) and voltage (b) distribution of a half wave dipole                                     | 15   |
| 2.3        | Center feed half wavelength dipole structure   | 16   |
| 2.4        | Radiation pattern of the dipole antenna  | 17   |
| 3.1        | Circuit schematic of the first order Koch  | 23   |
| 3.2        | Circuit design of the second order Koch  | 24   |
| 3.3        | The layout of the 3 <sup>rd</sup> order Koch   | 24   |
| 3.4        | Layout of the first design dipole antenna  | 25   |
| 3.5        | Layout of the meander lined dipole antenna   | 26   |
| 3.6        | Layout of the 3 <sup>rd</sup> order Koch dipole  | 26   |
| 3.7        | Layout of the modified 3rd order Koch  | 27   |
| 3.8        | SMA Port   | 28   |
| 3.9        | Waveguide port mode  | 30   |
| 3.10       | Simulated Koch Dipole Antenna  | 31   |
| 3.11       | Dipole Array Antenna   | 32   |
| 3.12       | Fractal Koch Dipole Array  | 32   |
| 3.13       | Front side photograph of the double sided planar folded dipole                                     | 34   |
| 3.14       | Back side photograph of the double sided planar folded dipole                                      | 34   |
| 3.15       | Front side photograph of the double sided planar modified 3 <sup>rd</sup> order Koch folded dipole | 35   |
| 3.16       | Back side photograph of the double sided planar modified 3 <sup>rd</sup> order Koch folded dipole  | 35   |
| 3.17       | Fabricated Koch Dipole Antenna with different flare angle  | 36   |

|      |   |    |
|------|---|----|
| 3.18 | Fabricated Fractal Koch Dipole Array  | 37 |
| 4.1  | Simulated return loss of the standard straight line dipole                            | 41 |
| 4.2  | Simulated return loss of the meandered line dipole                                    | 42 |
| 4.3  | Simulated return loss of the 3 <sup>rd</sup> order Koch curve dipole                  | 43 |
| 4.4  | Simulated return loss for single Koch dipole antenna<br>with different angle.         | 43 |
| 4.5  | 3D Radiation Pattern with different flare angle                                       | 44 |
| 4.6  | Simulated return loss for Fractal Koch Dipole Array                                   | 45 |
| 4.7  | 3D simulated radiation pattern for Fractal Koch Dipole Array                          | 45 |
| 4.8  | Measurement and simulation result for folded straight dipole                          | 47 |
| 4.9  | Measurement and simulation result of the folded modified Koch<br>dipole               | 48 |
| 4.10 | Measurement and simulation return loss of fractal Koch<br>dipole array                | 49 |
| 4.11 | Measured radiation pattern for the E-Co and E-Cross of the folded<br>straight dipole. | 50 |
| 4.12 | Measured radiation pattern for the H-Co of the folded<br>Koch antenna                 | 51 |
| 4.13 | Measurement result for E-Co and E Cross of the folded<br>Koch dipole                  | 52 |
| 4.14 | Measurement results for the H-Co radiation pattern of the folded<br>Koch dipole       | 52 |
| 4.15 | Measured radiation pattern for E-Plane of the fractal Koch dipole<br>array            | 53 |
| 4.16 | Measured radiation pattern for H- Plane of the fractal Koch dipole<br>array           | 54 |
| 4.17 | Measured Co & Cross Polar of the fractal Koch dipole array                            | 54 |

**LIST OF SYMBOLS**

|                  |   |                                     |
|------------------|---|-------------------------------------|
| $dB$             | - | decibel                             |
| $W$              | - | Width of rectangular patch antenna  |
| $L$              | - | Length of rectangular patch antenna |
| $\epsilon_r$     | - | Dielectric constant                 |
| $h$              | - | Substrate height                    |
| $\lambda_g$      | - | Guided wavelength                   |
| $f_u$            | - | Upper cutoff frequency              |
| $f_l$            | - | Lower cutoff frequency              |
| $d$              | - | distance between antenna elements   |
| $\theta$         | - | phase                               |
| $k$              | - | wave number                         |
| $\lambda_0$      | - | wavelength in free space            |
| $l$              | - | transmission line length            |
| $Z_0$            | - | characteristic impedance            |
| $w$              | - | transmission line width             |
| $\epsilon_{eff}$ | - | effective dielectric constant       |
| $c$              | - | velocity of light in free space     |
| $f_r$            | - | operating frequency                 |
| $BW\%$           | - | bandwidth in percentage             |

**LIST OF ABBREVIATIONS**

|             |   |                             |
|-------------|---|-----------------------------|
| <i>UHF</i>  | - | Ultra High Frequency        |
| <i>VHF</i>  | - | Very High Frequency         |
| <i>WLAN</i> | - | Wireless Local Area Network |

## **CHAPTER 1**

### **INTRODUCTION**

#### **1.1 Introduction**

During the past ten years, the mobile radio communications industry has grown by orders of magnitude, fuelled by digital and RF circuit fabrication improvements, new large -scale circuit integration, and other miniaturization technologies which make portable radio equipment smaller, cheaper, and more reliable. These trends will continue at an even greater pace during the next decade.

Wireless operations, such as long range communications, are impossible or impractical to implement with the use of wires. The term is commonly used in the telecommunications industry to refer to telecommunications systems (e.g., radio transmitters and receivers, remote controls, computer networks, network terminals, etc.) which use some form of energy (e.g.,radio frequency (RF), infrared light, laser light, visible light, acoustic energy, etc.) to transfer information without the use of wires. Information is transferred in this manner over both short and long distances. Applications may involve point-to-point ommunication, point-to-multipoint communication, broadcasting, cellular networks and other wireless networks.

Antenna is a very important component for the wireless communication systems using radio frequency and microwaves. By definition, an antenna is a device used to transform an RF signal, traveling on a conductor, into an electromagnetic wave in free space. The IEEE Standard Definitions of Terms for Antennas (IEEE Std 145-1983) defines the antenna or aerial as “a means for radiating or receiving radio waves”. In other words it is a transitional structure between free space and a guiding device that is made to efficiently radiate and receive radiated electromagnetic waves. Antennas are commonly used in radio, television broadcasting, cell phones, radar and other systems involving the use of electromagnetic waves. Antennas demonstrate a property known as reciprocity, which means that an antenna will maintain the same characteristics regardless if it is transmitting or receiving.

One of the applications of a one way wireless communication is the terrestrial television. Terrestrial television (also known as over-the-air, OTA or broadcast television) is the method of television broadcast signal (can be analog or digital) delivery by using radio waves from broadcast stations to televisions at homes using air as the medium. In terrestrial TV system, the transmitters (broadcast stations) are transmitting the TV signal with high power and very tall antenna transmitters located on the ground to transmit radio waves to the surrounding area. Viewers can pick up the signal with a much smaller antenna. The main limitation of broadcast television is range. The frequency range used by the terrestrial television includes the very high frequency (VHF) and ultra high frequency (UHF). The most common antenna used for receiving TV signals are the the Yagi-Uda antenna (variation of the dipole antenna) which is traditionally placed on the roof of the house.

One of the other types of the antenna is the planar antenna. The planar antenna has the most variation compared to any other types of antenna. Due to its advantages such



as low profile and the capability to be fabricated using the printed circuit technology, antenna manufacturers and researchers can come out with a novel design of antenna in house which will reduce the cost of its development. Planar antennas are also relatively inexpensive to manufacture and design because of the simple 2-dimensional physical geometry. They are usually employed at UHF and higher frequencies because the size of the antenna is directly tied to the wavelength at the resonant frequency.

Fractal geometries have been applied to antenna design to make multiband and broadband antennas. In addition, fractal geometries have been used to miniaturise the size of the antennas. However, miniaturization has been mostly limited to the wire (dipole and loop) antennas. The geometry of the fractal antenna encourages its study both as a multiband solution and also as a small (physical size) antenna. First, because one should expect a selfsimilar antenna (which contains many copies of itself at several scales) to operate in a similar way at several wavelengths. That is, the antenna should keep similar radiation parameters through several bands. Second, because the space-filling properties of some fractal shapes (the fractal dimension) might allow fractal shaped small antennas to better take advantage of the small surrounding space. The fractal antenna is formed by applying a generator shape repetitively at a constant scale factor and results in an antenna with log-periodic characteristics which is a multiband antenna and a miniaturization characteristic.

## 1.2 Problem Statement

Antenna elements are based on the size of the waves they're designed to receive, and the lower the frequency, the waves are longer, requiring a larger antenna surface to receive them. UHF TV antenna is significantly large and are intended for roof- or attic- mounting. The use of big outdoor UHF antenna should be replaced with a compact, less expensive and easily manufactured dipole antenna. The fractal geometry combined with the planar dipole can produce an antenna that has the benefit of being compact, low cost, and easily fabricated. The UHF band spanning from 470 MHz - 890 MHz is used for terrestrial TV broadcast. It will be very useful if the planar fractal antenna can be utilised in this frequency band.

## 1.3 Objectives

The objectives of this project are as follows:

To design, simulate and fabricate planar dipole antenna based on the Koch curve fractal geometry that has operating frequency within the lower UHF band i.e. 470MHz-890MHz which is the terrestrial TV signal frequency band.

## **1.4 Scope of Project**

- (i) Design the antenna based on previous similar works in published journals using antenna design software ,
- (ii) Simulate the proposed antenna using antenna design software (Agilent Advanced Design Systems and Computer Simulation Technology CST),
- (iii) Fabricate the antenna using the available materials (FR-4 Board).

## **1.5 Organisation of Project Report**

This project report consists of five chapters describing all the work done in the project. The project report organization is generally described as follows.

The first chapter explain the introduction of the project and problem this project try to solve which describe the motivation of this project. This chapter sets the work flows according to the objectives and scope of project.

Chapter two discuss the types of antennas, theories of planar and microstrip antenna, dipole configuration, and the fractal structure for antennas. Also the equation needed to design the planar dipole antenna is discussed.

Chapter three discuss the steps on designing the planar fractal dipole antenna,

the software used for design and simulation, the structure of the designed antennas, and the measurement techniques.

Result and analysis are presented in chapter four to compare the performance of all the designed antennas.

The last chapter highlights the overall conclusion of the project with future work suggestion to improve the design of the antenna. The project is summarized in this chapter to give general achievements and the future improvements can be made by other researchers in the future.

## **1.6 Summary**

This is an introductory chapter that defines the literature review, the objectives, and research background of the thesis. The project report structure is explained and highlighted. In the following chapters, the project work performed is reported.

## **CHAPTER 2**

### **LITERATURE REVIEW**

#### **2.1 Introduction**

An antenna or aerial is a transducer designed to transmit or receive radio waves which are a class of electromagnetic waves. In other words, antennas convert radio frequency electrical currents into electromagnetic waves and vice versa. Antennas are used in systems such as radio and television broadcasting, point-to-point radio communication, wireless LAN, radar, and space exploration. Antennas usually work in air or outer space, but can also be operated under water or even through soil and rock at certain frequencies for short distances.

#### **2.2 Classification of antennas**

##### **2.2.1 Frequency and size**

Antennas used for UHF are different from the ones used for VHF, which in turn are different from antennas for microwave. The wavelength is different at different frequencies, so the antennas must be different in size to radiate signals at the correct wavelength.

### **2.2.2 Directivity**

Antennas can be omnidirectional, sectorial or directive. Omnidirectional antennas radiate the same pattern all around the antenna in a complete 360 degrees pattern. The most popular types of omnidirectional antennas are the Dipole-Type and the Ground Plane. Sectorial antennas radiate primarily in a specific area. The beam can be as wide as 180 degrees, or as narrow as 60 degrees. Directive antennas are antennas in which the beamwidth is much narrower than in sectorial antennas. They have the highest gain and are therefore used for long distance links. Types of directive antennas are the Yagi, the biquad, the horn, the helicoidal, the patch antenna, the Parabolic Dish and many others.

### **2.2.3 Physical construction**

Antennas can be constructed in many different ways, ranging from simple wires to parabolic dishes, up to coffee cans. From the ones that are shaped like parabola, like fish bones, until the smallest and compact antenna like the ones printed on PCB.

### **2.2.4 Application**

Two application categories which are Base Station and Point-to-Point. Each of these suggests different types of antennas for their purpose. Base Stations are used for multipoint access. Two choices are Omni antennas which radiate equally in all directions, or Sectorial antennas, which focus into a small

area. In the Point-to-Point case, antennas are used to connect two single locations together. Directive antennas are the primary choice for this application.

All antennas radiate some energy in all directions in free space but careful construction results in substantial transmission of energy in a preferred direction and negligible energy radiated in other directions.

## **2.3 Antenna Properties**

There are several important antenna characteristics that should be considered when choosing an antenna for your application as follows:

### **2.3.1 Operating frequency**

The operating frequency is the frequency range through which the antenna will meet all functional specifications. It depends on the structure of the antenna in which each antenna type has its own characteristic towards a certain range of frequency. The operating frequency can be tuned by adjusting the electrical length of the antenna.

### 2.3.2 Return Loss

Return loss is the ratio, at the junction of a transmission line and a terminating impedance or other discontinuity, of the amplitude of the reflected wave to the amplitude of the incident wave. The return loss value describes the reduction in the amplitude of the reflected energy, as compared to the forward energy. Return loss can be expressed as equation 1.

$$RL = 20 \text{Log} \left| \frac{Z_1 + Z_2}{Z_1 - Z_2} \right| \quad (1)$$

where :

$Z_1$  = impedance toward the source

$Z_2$  = impedance toward the load

### 2.3.3 Bandwidth

Bandwidth can be defined as “the range of frequencies within which the performance of the antenna, with respect to some characteristics, conform to a specified standard”. Bandwidth is a measure of frequency range and is typically measured in hertz. For an antenna that has a frequency range, the bandwidth is usually expressed in ratio of the upper frequency to the lower frequency where they coincide with the -10 dB return loss value. The formula for calculating bandwidth is given in Equation (2).

$$\% BW = \frac{f_h - f_l}{\sqrt{f_h f_l}} \times 100\%$$

where :

$f_h$  = lower frequency that coincide with the -10 dB return loss value

$f_l$  = upper frequency that coincide with the -10 dB return loss value



### 2.3.4 Antenna radiation patterns

An antenna radiation pattern is a 3-D plot of its radiation far from the source. Antenna radiation patterns usually take two forms, the elevation pattern and the azimuth pattern. The elevation pattern is a graph of the energy radiated from the antenna looking at it from the side as can be seen in Figure 2.1a. The azimuth pattern is a graph of the energy radiated from the antenna as if looking at it from directly above the antenna as illustrated in Figure 2.1b. The combination of the two graphs shows the 3-D representation of how energy is radiated from the antenna (Figure 2.1c).

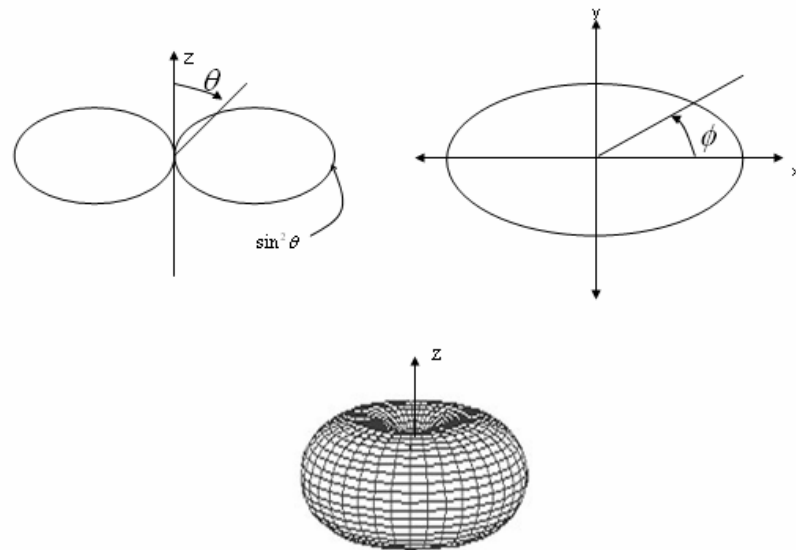

Figure 2.1 Radiation pattern of an antenna [6]

### 2.3.5 Power Gain

The power gain of an antenna is a ratio of the power input to the antenna to the power output from the antenna. This gain is most often referred to with the units of dBi, which is logarithmic gain relative to an isotropic antenna. An isotropic antenna has a perfect spherical radiation pattern and a linear gain of one.

### **2.3.6 Directivity**

The directive gain of an antenna is a measure of the concentration of the radiated power in a particular direction. It may be regarded as the ability of the antenna to direct radiated power in a given direction. It is usually a ratio of radiation intensity in a given direction to the average radiation intensity.

### **2.3.7 Polarization**

Polarization is the orientation of electromagnetic waves far from the source. There are two fields that will radiate from the antenna, the electrical field and the magnetic field. Polarization of the antenna or the orientation of the electric field (E- plane) of the radio wave is determined by physical structure of the antenna and its orientation with respect to the surface of the earth.

There are several types of polarization that apply to antennas. They are linear, which comprises, vertical, horizontal, and circular polarization is most important to get the maximum performance from the antennas. For linear polarization, the antenna radiates the electric field of the emitted radio wave to a particular orientation. For circular polarization, the antenna continuously varies the electric field of the radio wave through all possible values of its orientation with respect to the earth's surface. For best performance matching up the polarization of the transmitting antenna and the receiving antenna needs to be done.

## 2.4 TV Antenna Basics

There is no one antenna or antenna type that will deliver excellent TV reception in every location. The main factors determining reception are the distance and direction from the TV station transmitters to your home. Other factors include the transmitter's power and the height of its tower, the terrain between the tower and your antenna, and the size and location of any large buildings in the path of the transmission.

If the receiver is a few kilometres from the transmitter, and the signal path is relatively unobstructed, you may be able to get adequate reception using a small set-top indoor antenna. But as you move farther away, getting usable signal strength becomes trickier. This is where careful antenna selection and installation become essential.

Terrestrial TV signals can be broadcast over two different frequency ranges: VHF (Very High Frequency) and UHF (Ultra High Frequency). The VHF channel range is 2- 13, while the UHF range is 14-83. Over 90% of the stations currently broadcasting are in the UHF frequency band, meaning we can receive them with a UHF antenna. The frequency divisions for the UHF TV is given in table 2.1 below.

Antenna elements are based on the size of the waves they're designed to receive, and lower frequencies are lower so the waves are longer, requiring a larger antenna surface to receive them. It's possible to build a much more elaborate UHF antenna with more elements for stronger reception while keeping the antenna size physically manageable.

Table 2.1: Frequency band divisions for UHF TV channels [24]

| Ch. | Freq.<br>(MHz) | Ch. | Freq.<br>(MHz) | Ch. | Freq.<br>(MHz) | Ch. | Freq.<br>(MHz) |
|-----|----------------|-----|----------------|-----|----------------|-----|----------------|
| 14  | 470-476        | 32  | 578-584        | 50  | 686-692        | 68  | 794-800        |
| 15  | 476-482        | 33  | 584-590        | 51  | 692-698        | 69  | 800-806        |
| 16  | 482-488        | 34  | 590-596        | 52  | 698-704        | 70  | 806-812        |
| 17  | 488-494        | 35  | 596-602        | 53  | 704-710        | 71  | 812-818        |
| 18  | 494-500        | 36  | 602-608        | 54  | 710-716        | 72  | 818-824        |
| 19  | 500-506        | 37  | 608-614        | 55  | 716-722        | 73  | 824-830        |
| 20  | 506-512        | 38  | 614-620        | 56  | 722-728        | 74  | 830-836        |
| 21  | 512-518        | 39  | 620-626        | 57  | 728-734        | 75  | 836-842        |
| 22  | 518-524        | 40  | 626-632        | 58  | 734-740        | 76  | 842-848        |
| 23  | 524-530        | 41  | 632-638        | 59  | 740-746        | 77  | 848-854        |
| 24  | 530-536        | 42  | 638-644        | 60  | 746-752        | 78  | 854-860        |
| 25  | 536-542        | 43  | 644-650        | 61  | 752-758        | 79  | 860-866        |
| 26  | 542-548        | 44  | 650-656        | 62  | 758-764        | 80  | 866-872        |
| 27  | 548-554        | 45  | 656-662        | 63  | 764-770        | 81  | 872-878        |
| 28  | 554-560        | 46  | 662-668        | 64  | 770-776        | 82  | 878-884        |
| 29  | 560-566        | 47  | 668-674        | 65  | 776-782        | 83  | 884-890        |
| 30  | 566-572        | 48  | 674-680        | 66  | 782-788        |     |                |
| 31  | 572-578        | 49  | 680-686        | 67  | 788-794        |     |                |

## 2.5 Dipole Antenna

A dipole is a very basic antenna structure consisting of two straight collinear wires. The first thing to notice about a dipole is that it has two parts, hence the term “di” in its name. The fact that current can be driven into a dipole when the ends are open circuited, and therefore, do not have a closed loop is to consider the parasitic capacitance between the two arms of the antenna as the return current path, as shown in Figure 2.2. At high frequency this capacitance will represent low impedance. Current through this uncontrolled parasitic capacitance represents radiation. The current distribution for a half wave dipole is given in Figure 2.2 and the formula for the current distribution is given in Equation 3.

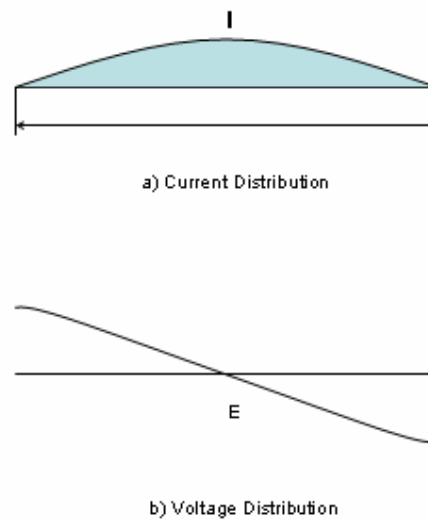

Figure 2.2: Current (a) and voltage (b) distribution of a half wave dipole

$$I = I_o e^{j\omega t} \cos k\ell, \quad k = \frac{2\pi}{\lambda} \quad (3)$$

where :

$I_o$  = input current (A)

$\ell$  = each dipole arm length (m)

$\lambda$  = wavelength (m)

Energy may also be fed to the half-wave antenna by dividing the antenna at its center and connecting the transmission line from the final transmitter output stage to the two center ends of the halved antenna. Since the antenna is now being fed at the center (a point of low voltage and high current), this type of feed is known as the Center-Feed or Current-Feed method. The point of feed is important in determining the type of transmission line to be used. This feeding technique is illustrated in figure 2.3 below.

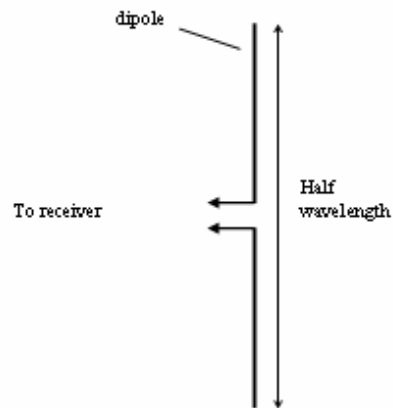

Figure 2.3: Center feed half wavelength dipole structure [10]

The dipole antennas have some general characteristics to be considered:

- (i) Omnidirectional

The dipole antenna has a unity gain in almost all directions. This characteristic can be seen from the far electrical field of the radiated electromagnetic wave in Equation (4).

$$E_0 = \frac{-jI_0}{2\pi\epsilon_0 cr} \frac{\cos(\frac{\pi}{2} \cos \theta)}{\sin \theta} e^{j(\omega t - kr)} \quad (4)$$

Where:

$\theta$  = angle of rotation

$\epsilon_0$  = the permittivity of vacuum

C = speed of light

r = the distance from the double to the point where the electrical field is evaluated

$\cos(\frac{\pi}{2} \cos \theta)$  is approximately equals to  $\sin \theta$ , then the resulting emission diagram is a slightly flattened torus.

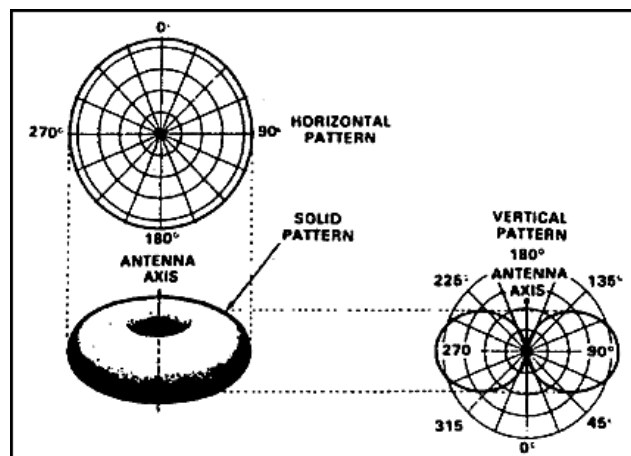

Figure 2.4: Radiation pattern of the dipole antenna [6]

The image in Figure 2.4 shows the radiation pattern of the half wavelength dipole. The image at the upper left shows the horizontal section of the radiation pattern, while the image at the lower right shows the horizontal section of the radiation pattern. The image at the lower left shows the perspective view of the same emission pattern.

(ii) Low gain

One of the drawbacks of dipole antenna is its low gain. Its omnidirectional characteristic makes its power distributed evenly on all directions so the power given to it is divided to many directions instead of one particular direction.

(iii) Easy to build

The dipole can be made only by using two pieces of conductor. So it can be easily build using any conducting materials such as copper wires.

(iv) No need ground plane

Unlike the monopole antenna which needs ground plane as a reflector, the dipole antenna does not need ground plane. The dipole has two radiating arms for which each are used to transmit or receive  $\frac{1}{4}$  wavelength.



## 2.6 Planar Antennas

Basically, a planar antenna is an antenna that has a two dimensional structure. It is usually build over a flat single layer PCB. Planar antennas are very popular because of their ease of fabrication. If the antenna is to be implemented on the same PCB as the circuitry, practically no additional costs arise. Planar antennas are also relatively inexpensive to manufacture and design because of the simple 2-dimensional physical geometry. They are usually employed at UHF and higher frequencies because the size of the antenna is directly tied to the wavelength at the resonant frequency.

For a system where an isotropic pattern is required, as for example in a portable device, a dipole is a good and easy approach. To get a good performance out of a dipole, one likes to design it as resonant dipole. This requires the dipole to be slightly less then half a wavelength long. A good approximation is 0.47 times the wavelength [3]. We can calculate the length of the resonant dipole with the Equation (5).

$$\ell = 0.47x \frac{v}{f} \quad (5)$$

Where  $v$  is the actual propagation speed on the dipole radials. This speed depends on the effective dielectric constant of the environment surrounding the radials. We can calculate the speed with the equation (6).

$$v = \frac{c}{\sqrt{\epsilon_{eff}}} \quad (6)$$

Where  $c$  is the speed of light in vacuum and  $\epsilon_{eff}$  is the effective dielectric constant of the surrounding media. The effective dielectric constant for a printed radial on a substrate depends on the geometry and the dielectric constant of the substrate. We can calculate the effective dielectric constant for a narrow trace

using equation (7).

$$\varepsilon_{eff} = \frac{\varepsilon_r + 1}{2} + \frac{\varepsilon_r - 1}{2} \left[ \left(1 + \frac{12h}{w}\right)^{-1/2} + 0.04\left(1 - \frac{w}{h}\right)^2 \right] \quad (7)$$

where:

$v$  = the actual propagation speed on the dipole radials

$h$  = thickness of the substrate,

$w$  = width of the trace

$\varepsilon_r$  = relative dielectric constant of the substrate used

$f$  = resonant frequency

$c$  = propagation speed of light

## **CHAPTER 3**

### **FRACTAL DIPOLE ANTENNA DESIGN**

#### **3.0 Introduction**

The design of the planar fractal antenna started by choosing the fractal structure suitable for this type of antenna. The choice is based on theories of fractals and results from published journals about fractal antennas.

#### **3.1 Antenna Design Specifications**

The antenna designed for this project should have the following specifications:

(a) Planar antenna

Antenna is built on a flat surface double layer PCB (copper layered).

(b) Operating at the lower frequency of the UHF band (470-890MHz)

The frequency band 470-890 MHz is chosen because it is the band that is used for terrestrial UHF TV channels and for new applications like a Digital TV Broadcasting.

(c) Dipole antenna

Dipole is chosen because it has the omnidirectional radiation pattern so it can receive TV signals no matter which side the antenna is facing.

(d) Koch curve fractal geometry

The Koch curve fractal structure is chosen because of its miniaturization characteristic.

(e) Uses FR4 substrate.

The PCB that is used is the FR4 (Fire Retardant – 4) type board. The reasons for choosing this type of board are because of the low cost and ease of fabrication. The FR-4 board has a relative dielectric constant of  $\epsilon_r = 4.7$  with tangent loss of 0.019; it has a 1.6 mm substrate thickness and a 0.035 mm copper thickness.

(f) Antenna is used to receive signals.

Antenna is receive only because terrestrial TV is broadcast one way communication which does not need any reply or acknowledgments signals from the receiver side.

### 3.2 Design of the antenna using antenna design software

There are various software in the market that can be used to design the antenna or RF component for example Computer Simulation Technology, Advance Design System ADS, HFSS, Applied Wave Research AWR and many more. In this design, three software have been used to design the antenna. The design of the antenna is divided into 2 steps. The first one is designing the antenna structure using circuit in the schematic feature of the AWR Microwave Office. This step is taken only for the Koch curve structure. Figure 3.1 shows the circuit of the 1<sup>st</sup> order Koch which is made of segments of copper combined together.

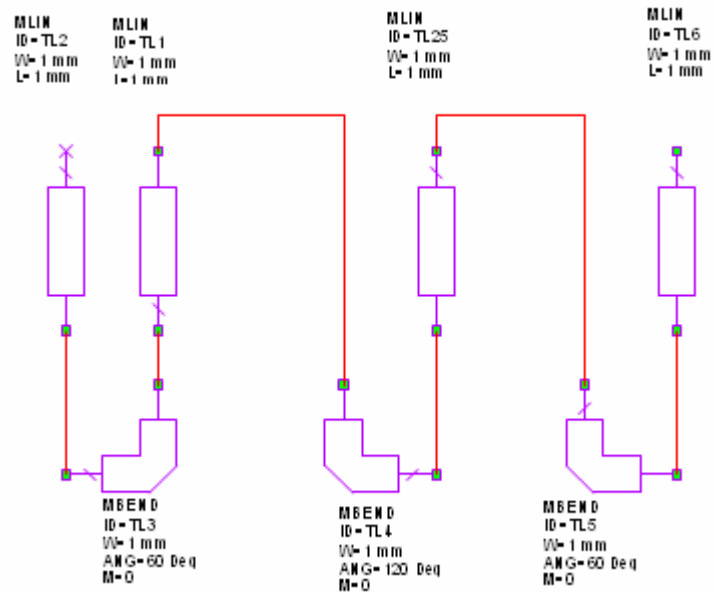

Figure 3.1: Circuit schematic of the first order Koch

Figure 3.2 shows the circuit of the 2<sup>nd</sup> order Koch which is made out of the 1<sup>st</sup> order Koch circuits combined.

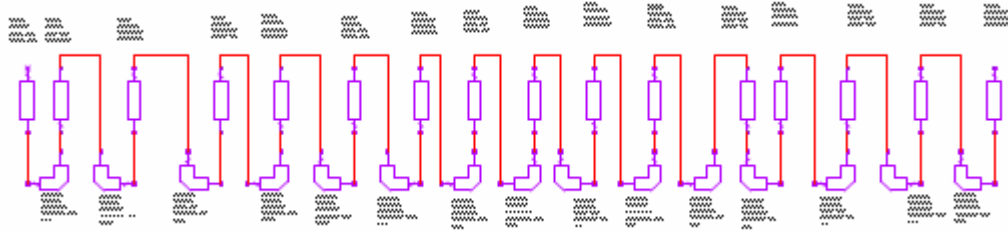

Figure 3.2: Circuit design of the second order Koch

Figure 3.3 shows the layout of the 3<sup>rd</sup> order Koch which is made out of the 2<sup>nd</sup> order Koch circuits in figure 3.2 combined.

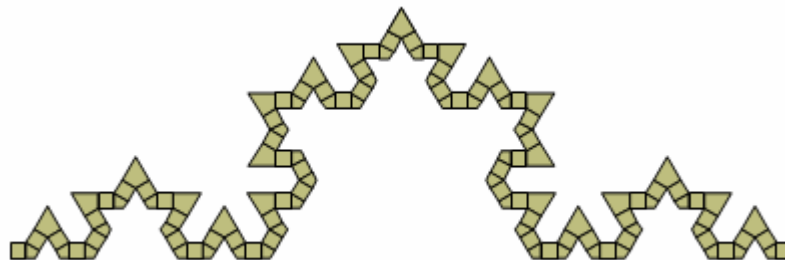

Figure 3.3 : The layout of the 3<sup>rd</sup> order Koch

This step is taken only for the Koch curve structure, because the Agilent ADS software does not have the feature to make Koch curve in its schematic. After designing the circuit, the layout is generated. After that, the layout is exported in GDSII format. Then in ADS software, the GDSII file is imported and rebuilds the layout in its layout window.

The first design is the standard straight line dipole with the dimension and structure depicted in figure 3.4.

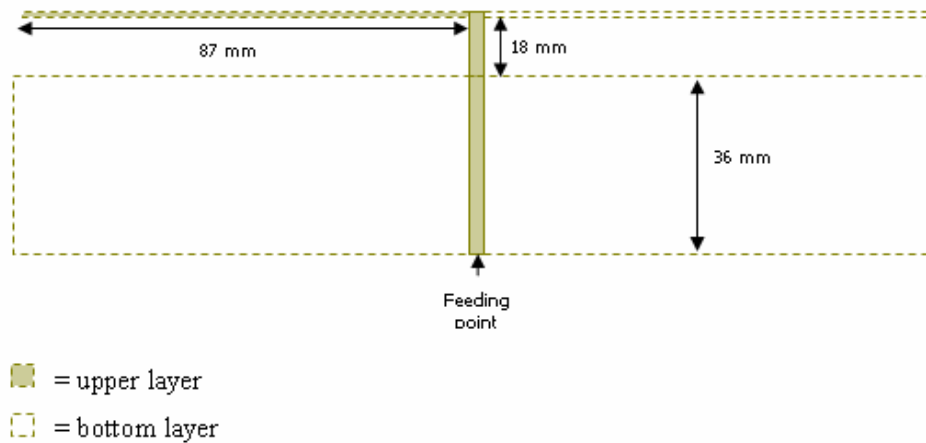

Figure 3.4: Layout of the first design dipole antenna

The width of the radial (dipole arms) and the width of the transmission line are kept constant at 1mm and 3mm. The structure is consisted of two dipole arms which are located on different sides of the board. The transmission line connects the port (SMA connector) to the two dipole arms. The conductor plane on one side of the board is called the truncated ground plane which is used to reproduce the effect of the electric circuitry on the same PCB and also acts as a reflector element.

The second design is the modified dipole called meandered dipole with the dimension and structure depicted in Figure 3.5.

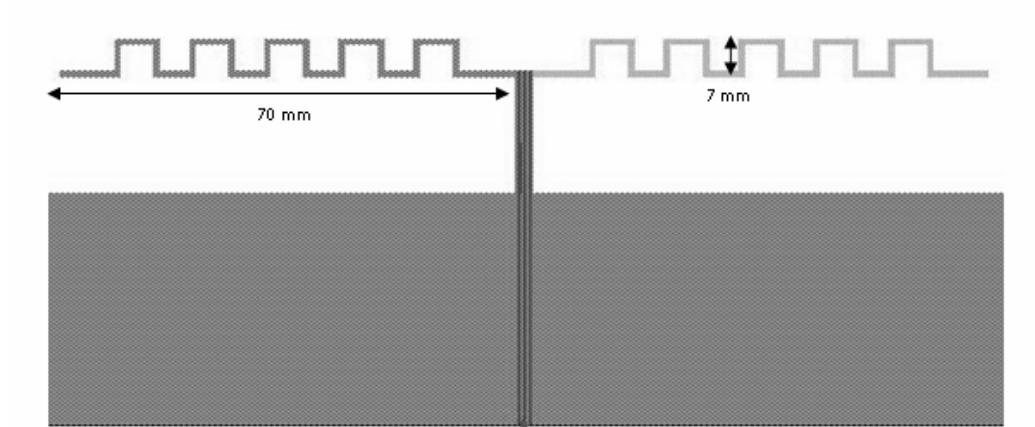

Figure 3.5: Layout of the meander lined dipole antenna

The third design is the 3<sup>rd</sup> order Koch dipole with the dimension and structure depicted in figure 3.6.

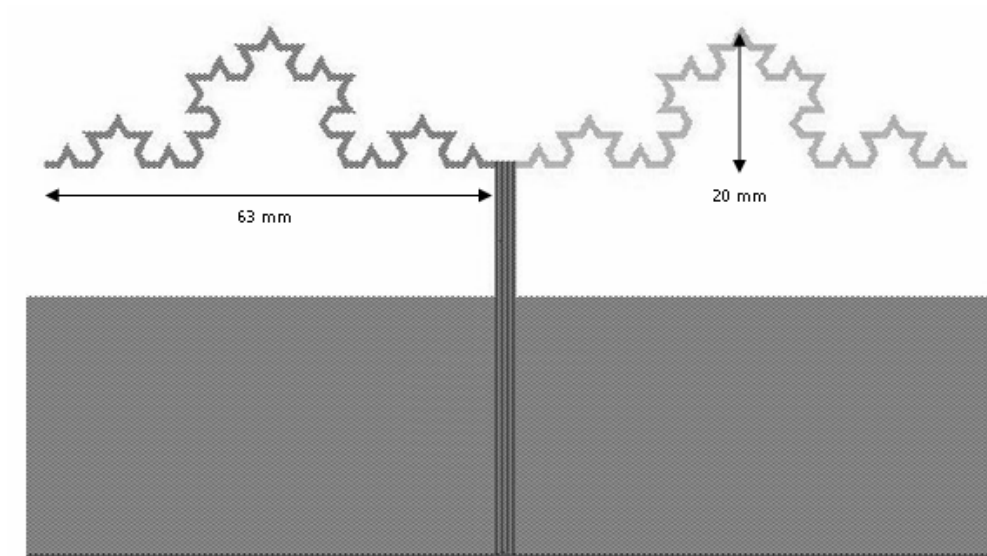

Figure 3.6: Layout of the 3<sup>rd</sup> order Koch dipole



The fourth design is the modified dipole called folded dipole with the dimension and structure depicted in figure 3.7.

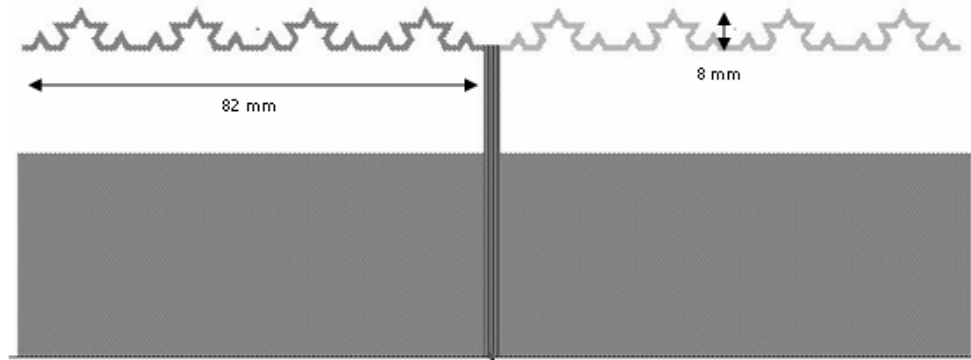

Figure 3.7: Layout of the modified 3rd order Koch

This antenna is made of 2<sup>nd</sup> order Koch curve constructed in series. Where it is actually a 3<sup>rd</sup> order Koch but without the 120 degrees bending in the middle. This measure is taken to minimize the height of the total antenna.

### 3.3 Simulation Using Computer Simulation Technology (CST)

This part shows the designed and simulation of the antenna using Computer Simulation Technologies CST 2008. By using CST, all the component of device need to be design as actual. There is a little bit complicated in term of parameter setting and friendly used compare to AWR or ADS but it's suitable for microwave design especially in antenna and RF design.

### 3.3.1 SMA and Waveguide Port Connector

In this part, the SMA connectors are designed to be 50 ohm impedance as a feeding point to the antenna. The mode port needs to be reacting as a TEM mode for SMA and Quasy TEM for waveguide port. The design parameters of SMA port are as follow:

Cr ( Core radius) = 0.4mm

Tr (Teflon radius ) = 1.35 mm ( epsilon = 2.08)

Gr (Ground port radius) = 1.75mm

Figure 3.8 shows the prototype of 50 Ohm SMA port and port mode while figure shows the fundamental mode for waveguide port.

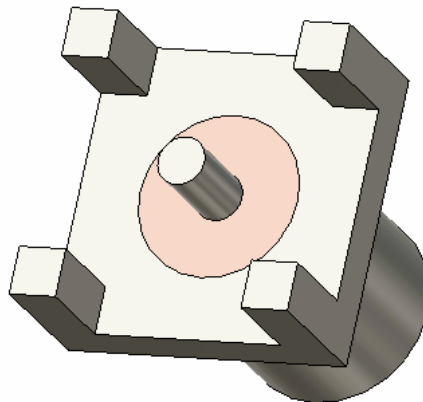
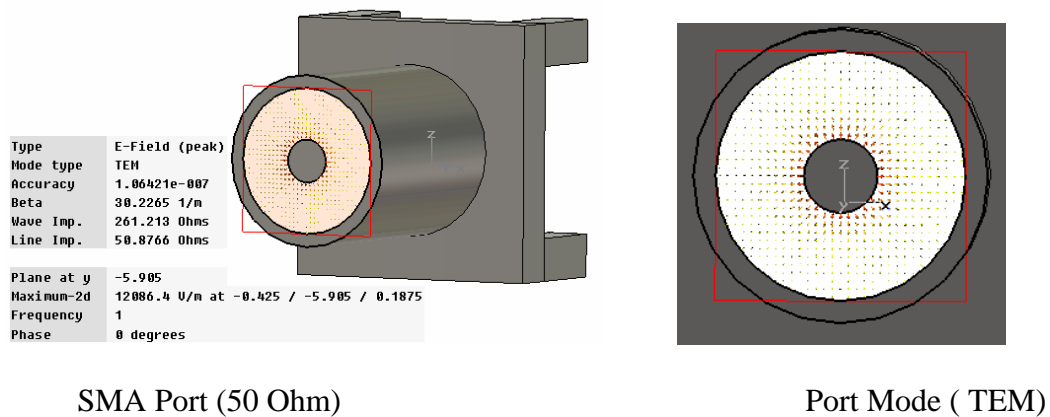
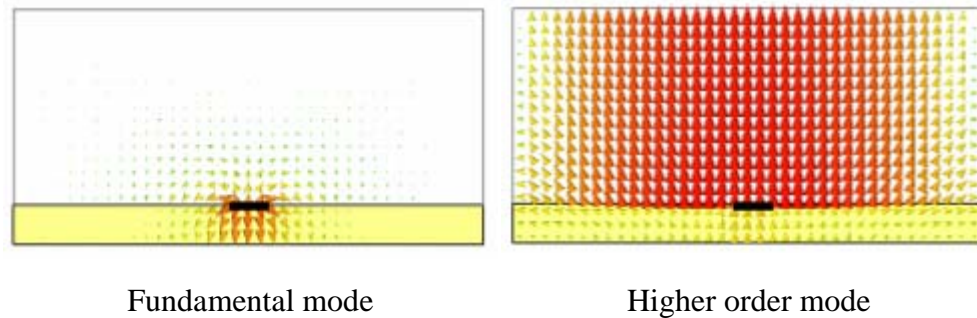

Figure 3.8: SMA Port

### 3.3.2 Fundamental Quasi-TEM mode

In general, the size of the port is a very important consideration. On one hand, the port needs to be large enough to enclose the significant part of the microstrip line's fundamental quasi-TEM mode. On the other hand, the port size should not be chosen unnecessarily large because this may cause higher order waveguide modes to propagate in the port.

The following pictures show the fundamental microstrip line mode and higher order mode.



a) Port mode

The higher order modes of the microstrip line are very similar to modes in rectangular waveguides. This behavior can be explained by an enclosure that is automatically added along the port's circumference for the port mode calculation. The boundary conditions at the port's edges will adopt the settings from the 3D model.

The larger the port, the lower the cut-off frequency of these modes. Since the higher order modes are somewhat artificial, they should not be considered in the simulation. Therefore, the port size should be chosen small enough that the higher order modes can not propagate, and only one (fundamental) mode should be chosen at the port. If higher order microstrip line modes become propagating, this normally results in

very slow energy decays in the transient simulations and sharp spikes in the frequency domain simulation results, respectively. On the other hand, choosing a port size too small will cause degradation of the S-parameter's accuracy or even instabilities of the transient solver. If you experience an unexpected behavior like this, check the size of the ports.

As a rule, the size of the port should be chosen according to the following picture:

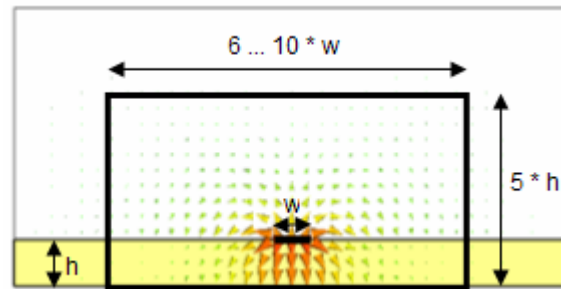

b) Fundamental mode

Figure 3.9: Waveguide port mode

Ideally, the port 10 times as wide as the width of the microstrip line, but this may be reduced to around 6 times the microstrip line width in case of geometrical constraints.

### 3.4 Simulated Single Koch Dipole

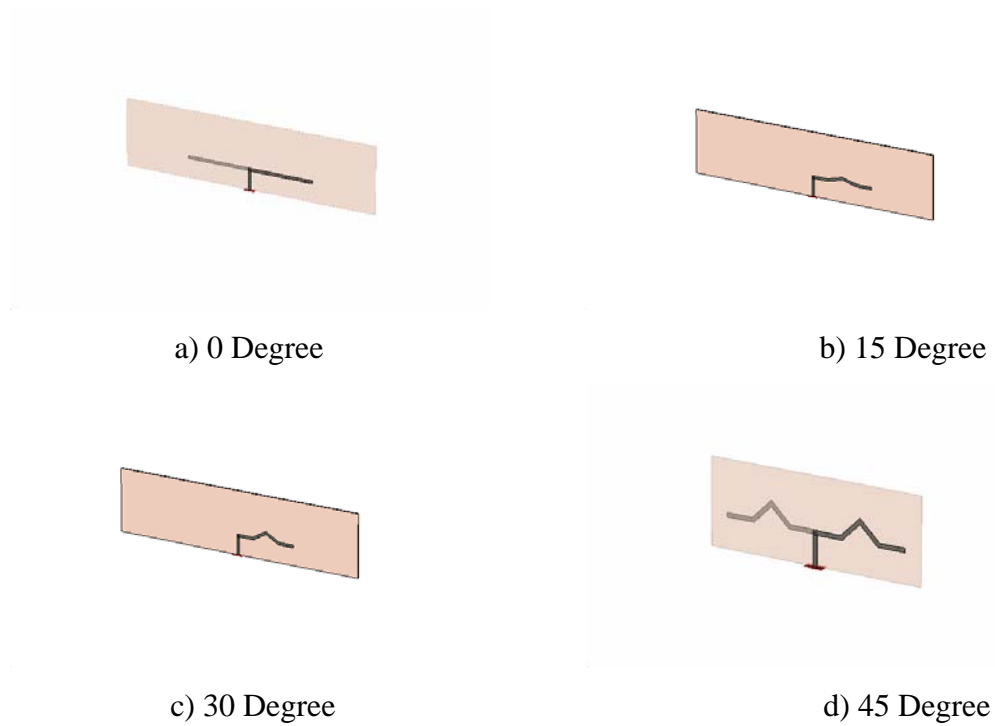

Figure 3.10: Simulated Koch Dipole Antenna

Figure 3.10 shows the design of single Koch dipole antenna with different flare angle. By changing the value of flare angle, the length of the arm of the dipole can be miniaturized or shrink. The results of the fabricated single Koch dipole are shown in chapter 4.

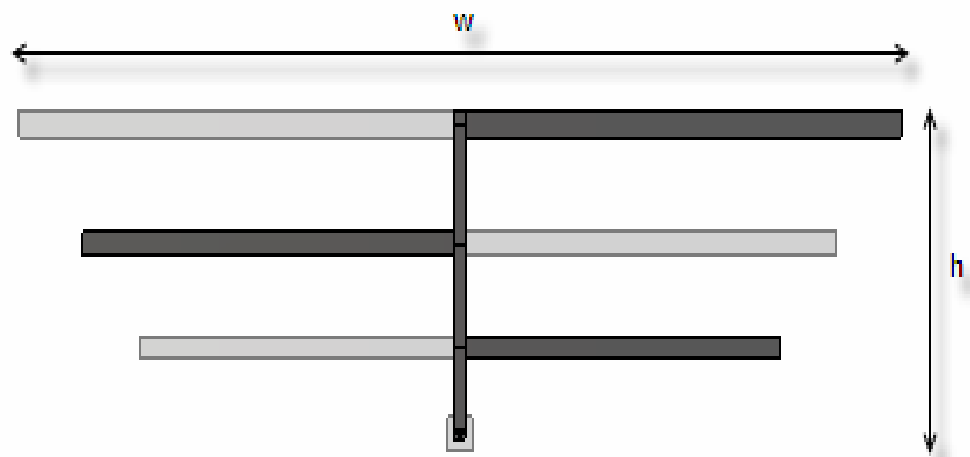

Figure 3.11: Dipole Array Antenna

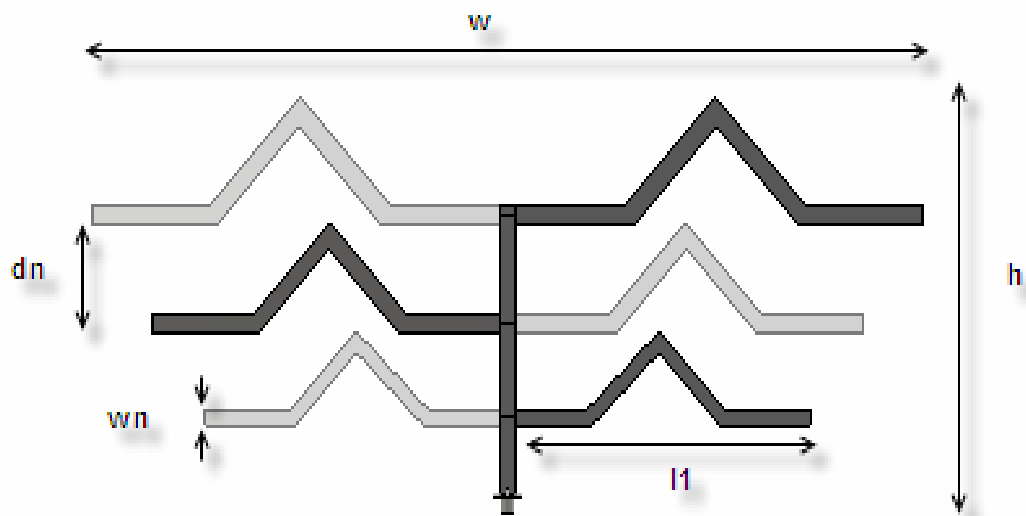

Figure 3.12: Fractal Koch Dipole Array

The second design using CST is Fractal Koch Dipole Array as depicted in figure 3.12. The best result for this design are fabricated and measured and it's shows in next chapter. Figure 3.11 shows the dipole array while figure 3.12 is fractal Koch dipole array with 40 degree angle. It can be seen that, the fractalized Koch dipole become smaller compared to straight dipole around 15 percent.

### **3.5 Fabrication of the antenna**

The fabrication of the designed antenna involved the photolithography process and used wet etching technique.

Firstly, the design layout from the software is exported to a DXF file. DXF file is one of the file formats that can be read by the AutoCAD software. The AutoCAD software is used to print out the layout in a 1:1 scale factor on a transparency paper. The printing is done layer by layer, the upper layer and the bottom layer is printed separately. After printing, the printed transparency is put on top of the FR4 board and the layout is aligned with the board, then it is exposed to UV light for around 2.5 minutes. This step is repeated for the other side of the board. After exposing the board to the UV light, the board is soaked in developer solution. This process is done until the layouts on both layers are visible on the board and are dark in colour. This step is followed by cleaning the board with pure water to dispose of the developer solution remained, and then the board is soaked in hot etching solution ( $\text{FeCl}_2$ ). This solution made a chemical reaction with the copper on the board and will etched away the copper. This procedure took about 30 minutes and was done until the unwanted copper on the board was etched away. After the photolithography and wet etching is done,

the board was cleaned and dried. Then the antenna was soldered to a 50 Ohm SMA connector for connection to external devices such as the measurement devices. All antennas that were successfully designed are fabricated. The result for simulated and measured antenna was test and analysis and shows in chapter 4.

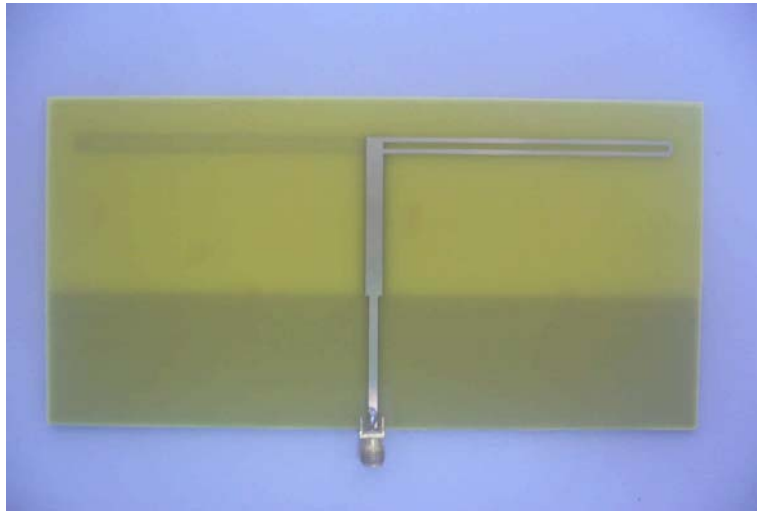

Figure 3.13: Front side photograph of the double sided planar folded dipole



Figure 3.14: Back side photograph of the double sided planar folded dipole



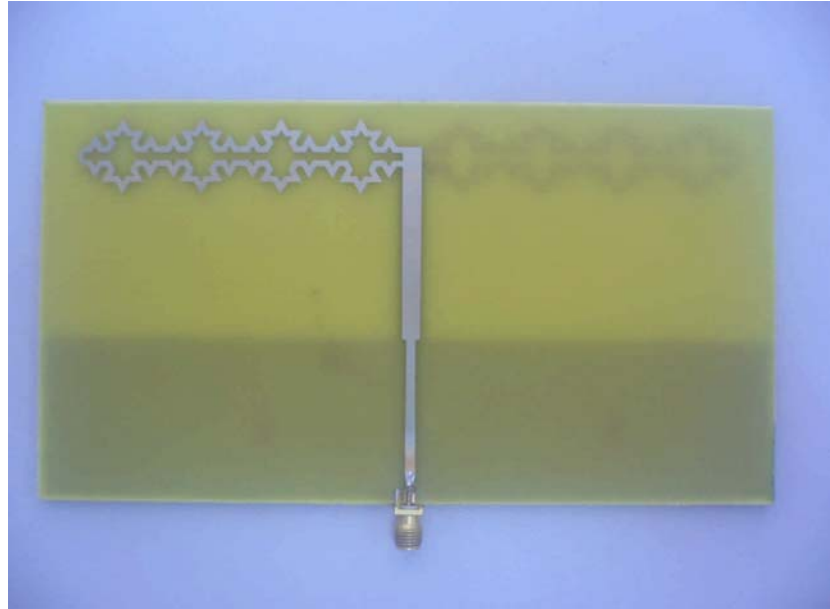

Figure 3.15: Front side photograph of the double sided planar modified 3<sup>rd</sup> order Koch folded dipole

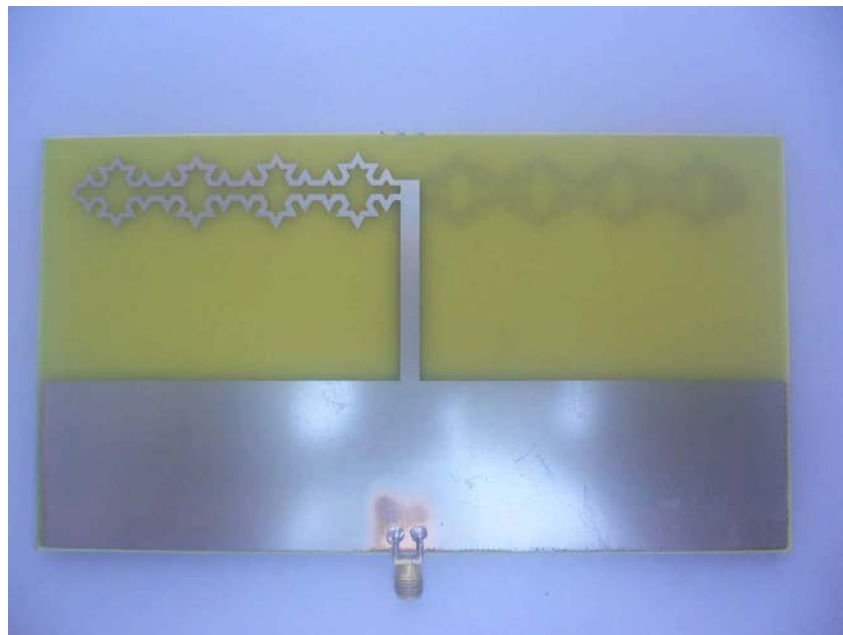
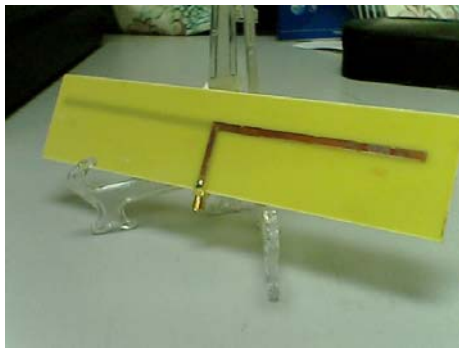
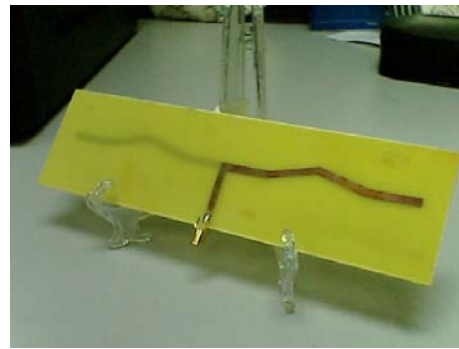

Figure 3.16: Back side photograph of the double sided planar modified 3<sup>rd</sup> order Koch folded dipole



a) 0 degree



b) 15 Degree

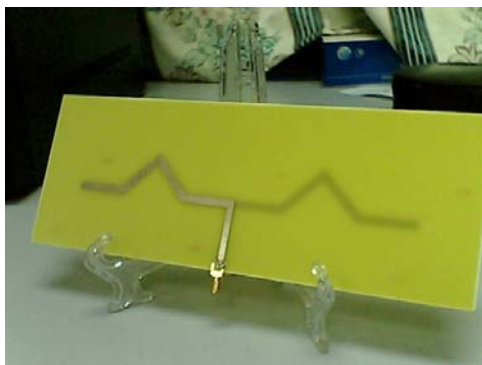

c) 30 Degree

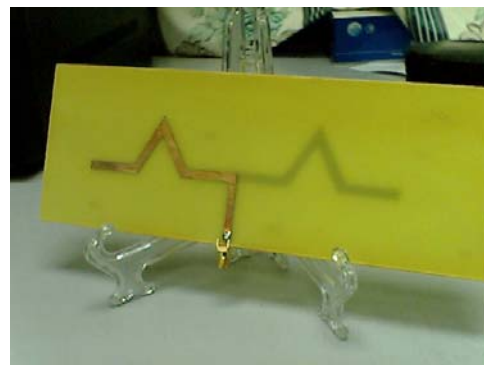

d) 45 Degree

Figure 3.17: Fabricated Koch Dipole Antenna with different flare angle

Figure 3.17 shows the fabricated Fractal Koch Dipole antenna with different flare angle. The comparison for each antenna in term of size reduction has been done.

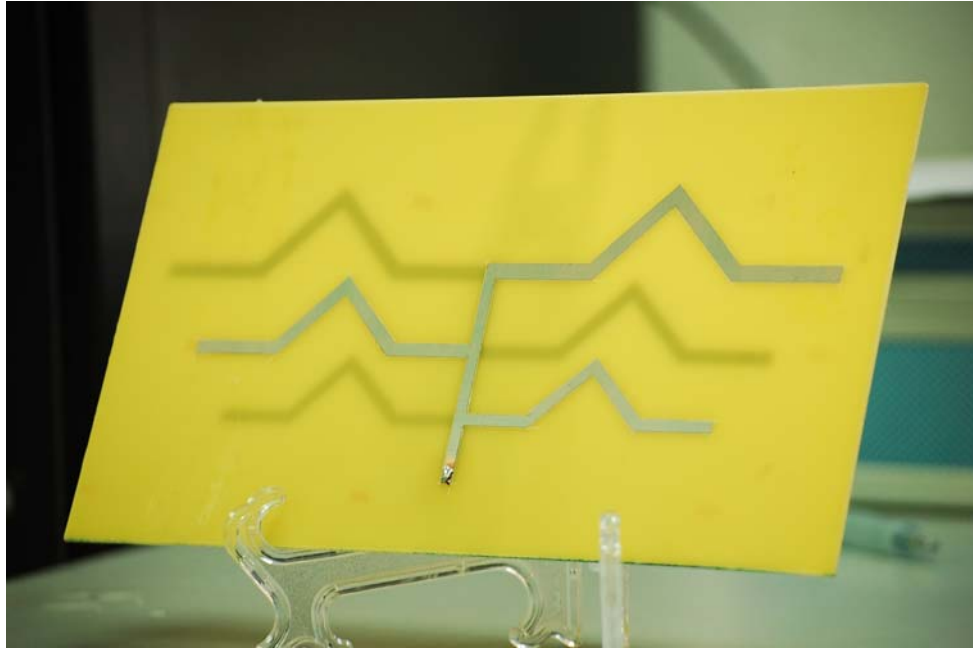

Figure 3.18: Fabricated Fractal Koch Dipole Array

## 3.6 Measurements of the Antenna

### 3.6.1 Input Return Loss Measurement

After fabricating the antenna, testing is done to determine the performance of the antenna. The property of the antenna that is measured is the input return loss. The return loss is measured using the Marconi Instruments Microwave Test Set 6204 and Vector Impedance Analyzer Via Echo V2.5.

After connecting the antenna to this device, the first step in using the Marconi Instrument is to set the frequency range that will be analyzed. For this antenna, the frequency range is set to 400 to 900MHz. The next step is to do the calibration. Calibration is done to ensure the precision of the instrument for any spectrum. After

that, measurement is done and the device will sweep the frequency band and plot the return loss of the antenna and display it on the screen.

### **3.6.2 Radiation Pattern Measurement**

There is one more property of the antenna that can be measured which is the radiation pattern. The measurement of radiation pattern requires a signal generator, transmitting antenna, a rotating machine and a spectrum generator. The measurement is done in an anechoic chamber which is a special chamber for measuring signal power of antennas. The antenna under test is attached on the rotating machine.

The antenna designed (antenna under test) will act as a receiving antenna. The transmitting antenna used is a standard indoor TV dipole antenna with retractable radials in both directions that makes  $180^\circ$  angle between each other. This dipole antenna can be stretched and shortened to suit the length of the operating frequency. Both the receiving and transmitting antenna will be placed aligned to each other in the chamber.

The measurements are done 6 times, three for the folded straight dipole antenna and three for the folded Koch antenna. First, the co-polarization in the E plane is measured. Both the receiving and transmitting antennas are placed in vertical positions. Then the receiving antenna is rotated  $360^\circ$  while the measured data is collected. The next step is to measure the cross-polarization in the E plane. The receiving antenna is placed in a horizontal position. Then the receiving antenna is rotated  $360^\circ$  while the measured data is collected. The last step is to measure the co-polarization in the H

plane. Both the receiving and transmitting antennas are placed in horizontal positions. Then the receiving antenna is rotated  $360^\circ$  while the measured data is collected.

### **3.7 Summary**

This chapter discusses the design of different kinds of planar dipole antennas structure. The design includes the standard straight line dipole, the meandered line dipole antenna, the 3<sup>rd</sup> order Koch curve dipole, the folded dipole, the folded Koch curve dipole and fractal Koch dipole array. The design process involves the use of three antenna design software. One is the AWR Microwave Office, Agilent ADS and Computer Simulation Technology CST. After designing the layout of the antenna, simulation is done for each antenna. Simulation is done for the return loss and the 3D radiation pattern of the antenna. This fabrication process is done using the photolithography and wet etching technique. After fabrication is finished, the measurement process is done using the available test equipments in the lab. The results of the measurement are presented in chapter 4.

## **CHAPTER 4**

### **RESULTS AND DISCUSSION**

#### **4.0 Introduction**

The measurement results for passive antenna designed in this project can first be simulated using the Agilent ADS software and Computer Simulation Technology CST. This software uses the Method of Moments (MoM) to calculate and predict the properties of the designed antenna. The simulation is done to get the predicted values of the input return loss and the radiation pattern of the passive antennas. The simulation results are based on the antenna designs in Chapter 3.

#### **4.1 Antenna Simulation Results**

##### **4.1.1 Standard straight line dipole**

Figure 4.1 shows the return loss of the antenna. Here it can be seen that it has a resonant frequency at about 575 MHz with the return loss value of

about -13 dB. The bandwidth is calculated from the lower frequency values which intercept the -10 dB value of the return loss, until the upper frequency value which intercept the -10 dB value of the return loss. Calculation from equation (2) in chapter 2 gives us the bandwidth of 0.7%.

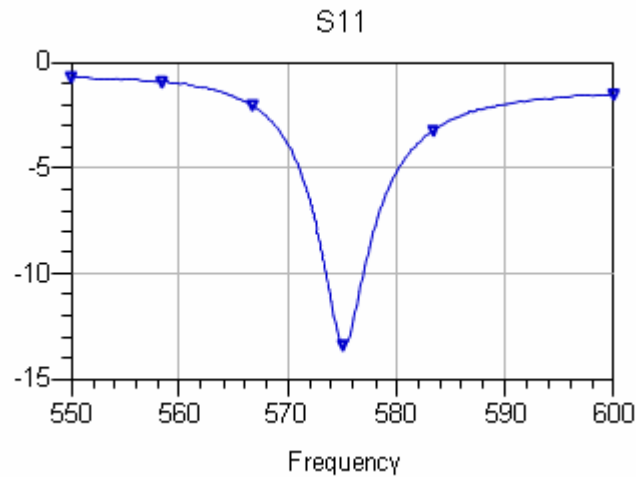

Figure 4.1: Simulated return loss of the standard straight line dipole

Figure 4.2 shows the return loss of the antenna. Here it can be seen that it has a resonant frequency at about 575 MHz with the return loss of about -24 dB. The resonant frequency is made the same as the straight line dipole in section 4.2.1. Calculation from equation (2) in chapter 2 gives us the bandwidth of the meandered line dipole designed about 0.7%. The meander line dipole shows a miniaturization characteristic which is shown by the shorter length of the dipole arms compared to the straight line dipole. With a dimension height of only 7 mm, the meander managed to decrease the length of the dipole from 177 mm to 143 mm.

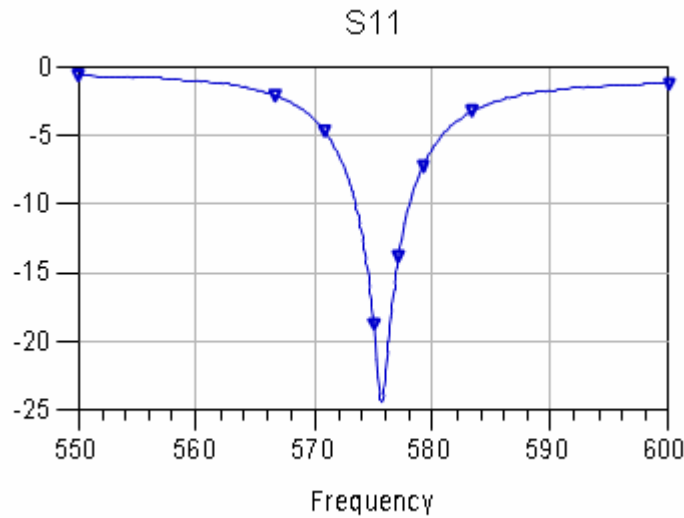

Figure 4.2: Simulated return loss of the meandered line dipole

#### 4.1.2 3<sup>rd</sup> order Koch curve dipole

Figure 4.3 shows the return loss of the antenna. Here it can be seen that it has a resonant frequency at about 575 MHz. The resonant frequency is made the same as the straight line dipole in section 4.2.1. From here, we can calculate the miniaturization factor of the 3<sup>rd</sup> order Koch compared to the straight line dipole. From Equation (10), comparison can be made between the length of the Koch curve dimension from the calculation and from the simulation. The calculation (Equation 10) gives the value of  $177 \text{ mm} / 2.37 = 74.68 \text{ mm}$ . The simulation give us the dimension of 126 mm. From this calculation we can conclude that the physical length of the Koch curve does not equal to the electrical length.



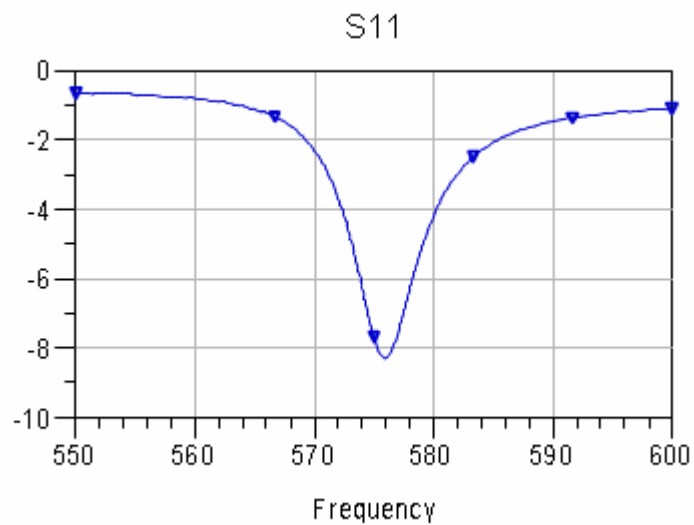

Figure 4.3: Simulated return loss of the 3<sup>rd</sup> order Koch curve dipole

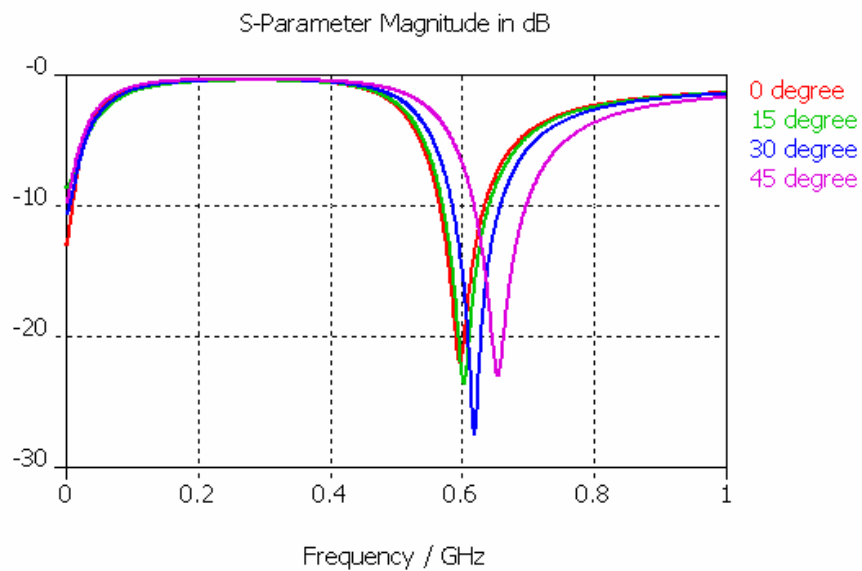

Figure 4.4: Simulated return loss for single Koch dipole antenna with different angle.

The simulated return loss for single Koch dipole antenna as depicted in figure 4.4 shows that for every increment of the angle, the return loss has a little bit shifted to the upper frequencies. It's may be due to the shrinking of the length of the dipole.

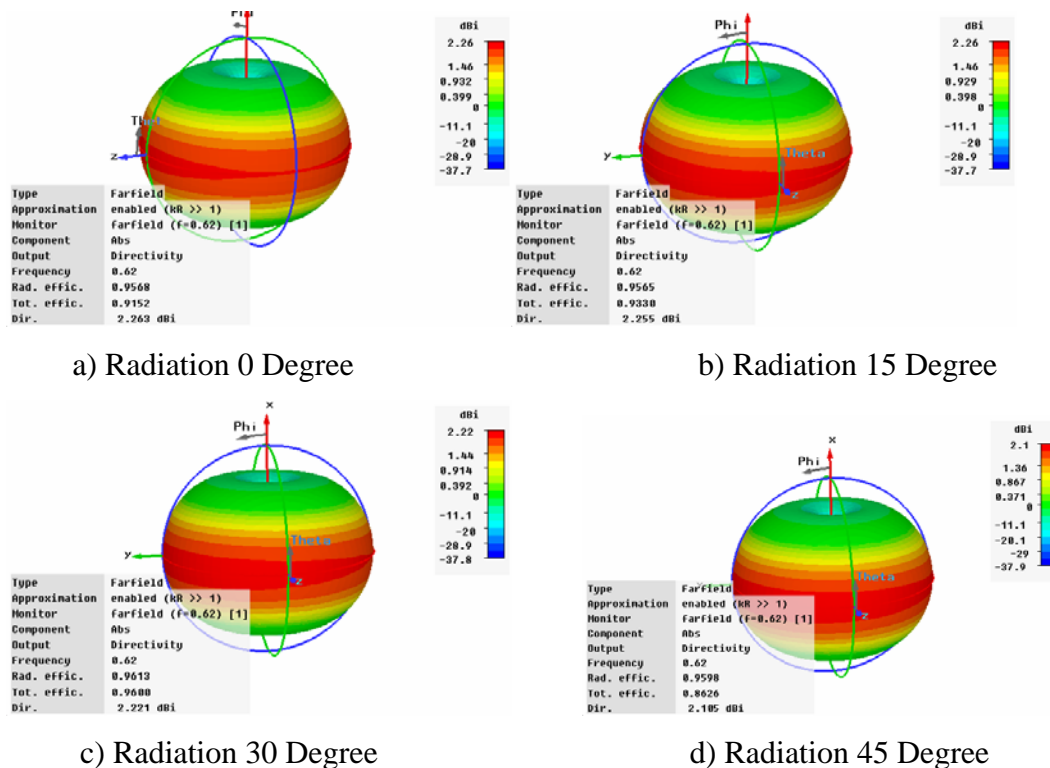

Figure 4.5: 3D Radiation Pattern with different flare angle

Figure 4.5 shows the 3D simulated radiation pattern for single Koch dipole antenna. It does can be seen that all single Koch dipole antenna gives similar efficiency and gain which 96% and 2.2 dBi respectively. The red area of the radiation shows the strongest field of the dipole. The figure also shows that the radiation patterns of the dipole are omnidirectional.

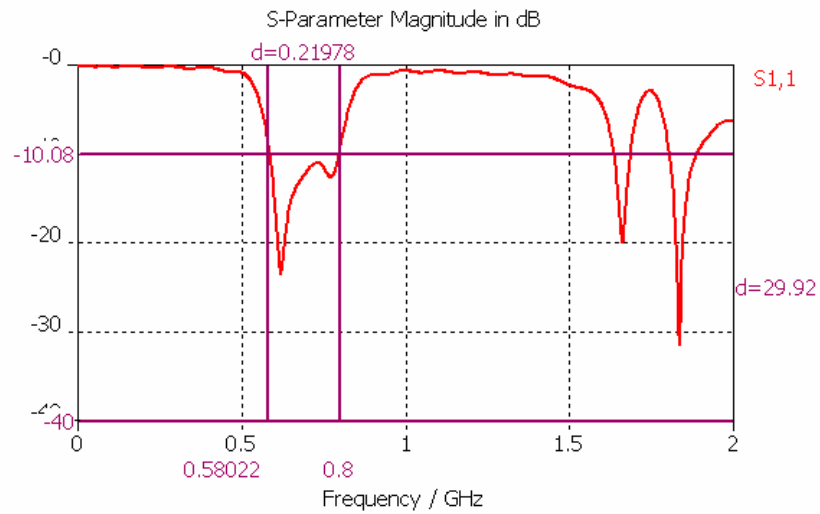

Figure 4.6: Simulated return loss for Fractal Koch Dipole Array

Figure 4.6 shows the return loss of the Fractal Koch Dipole Array antenna. Here it can be seen that it has a resonant frequency start from 580 MHz up to 800 MHz.

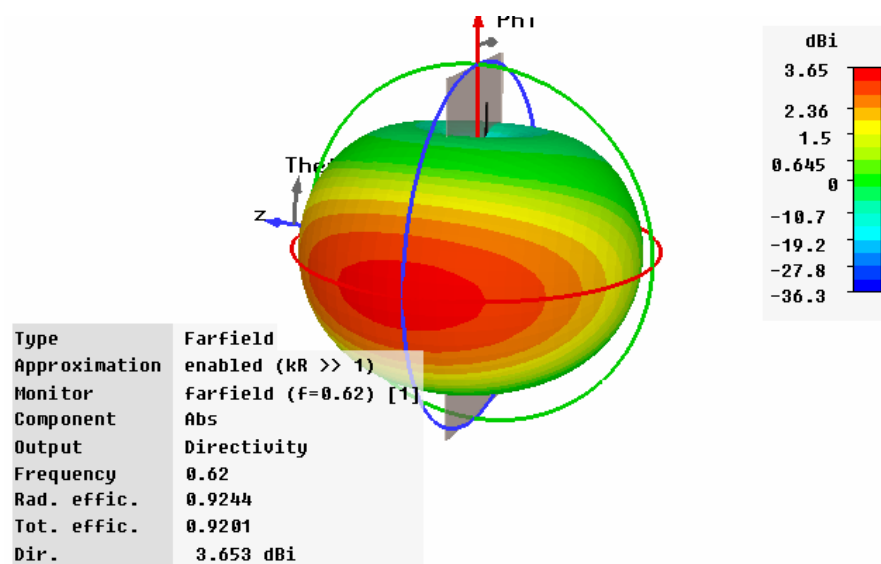

Figure 4.7: 3D simulated radiation pattern for Fractal Koch Dipole Array

Figure 4.7 shows the simulated 3D radiation pattern. From that, it can be seen that the radiation is towards the smaller element. This phenomenon so called back fire radiation. The red colour means the strongest field of the radiation. This is due to phase reversal where the dipole is connected to the centre of the transmission line. If phase reversal is not used, the radiation will occur in end fire radiation (towards larger element). This causes scalloping in amplitude pattern and fluctuation in impedance behaviour.

## **4.2 Antenna Measurement Results**

This part discussed the measured result for all the fabricated antennas in term of return loss and radiation pattern.

### **4.2.1 Return Loss Measurement Results**

The measurement and simulation results for the return loss of the folded straight dipole antenna are shown in Figure 4.8. The measurement result shows a resonant frequency of 815 MHz with return loss about -14 dB. The bandwidth is 6.6% which is from 785 MHz to 823 MHz.

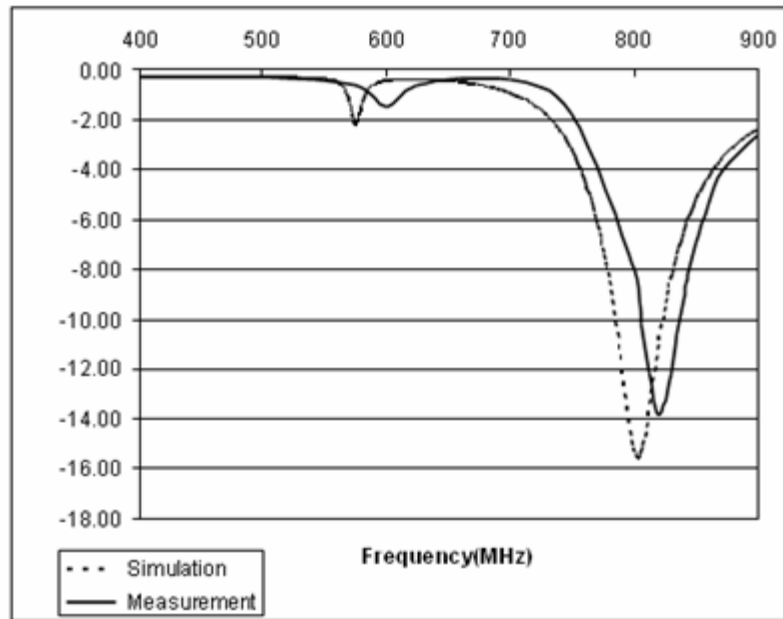

Figure 4.8: Measurement and simulation result for folded straight dipole

This result shows a quite similar return loss from the simulation result which is -15.5 dB. The bandwidth achieved is the same as the simulation result. From the graph it can be seen that the frequency shifted about 10 MHz lower than the simulation result. This can be caused by the approximation calculation done by the software and combined with the surrounding external factor. This is because the behaviour of the antenna depends on so many factors that the simulation can only give the best case scenario. Beside of those factor, there are also the substrate and fabrication factor. The Substrate may have a slightly different dielectric values than is written in the specification sheet. The fabrication process uses manual photolithography and wet etching technique. The deviation can be produced from the difference of a few hundred microns on the printed mask on the transparency, until the wet etching which does not produce an accurate etching on the edges.

The measurement and simulation results for the return loss of the folded modified Koch dipole antenna is shown in Figure 4.9. The measurement result shows a resonant frequency of 715 MHz with return loss about -18 dB. The bandwidth is 7% which is from 680 MHz to 730 MHz.

This result shows a quite similar return loss from the simulation result which is -24 dB. The bandwidth achieved is better than the simulation result. From the graph it can be seen that the frequency shifted about 40 MHz lower than the simulation result. This can be caused by the approximation calculation done by the software, especially with more complex structure compared than the straight dipole, and combined with the surrounding external factor that affected the measurement.

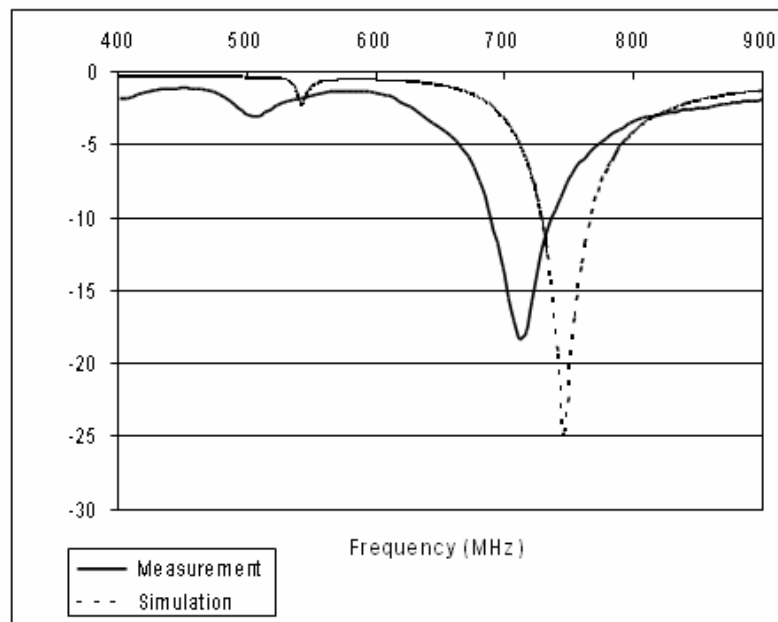

Figure 4.9: Measurement and simulation result of the folded modified Koch dipole

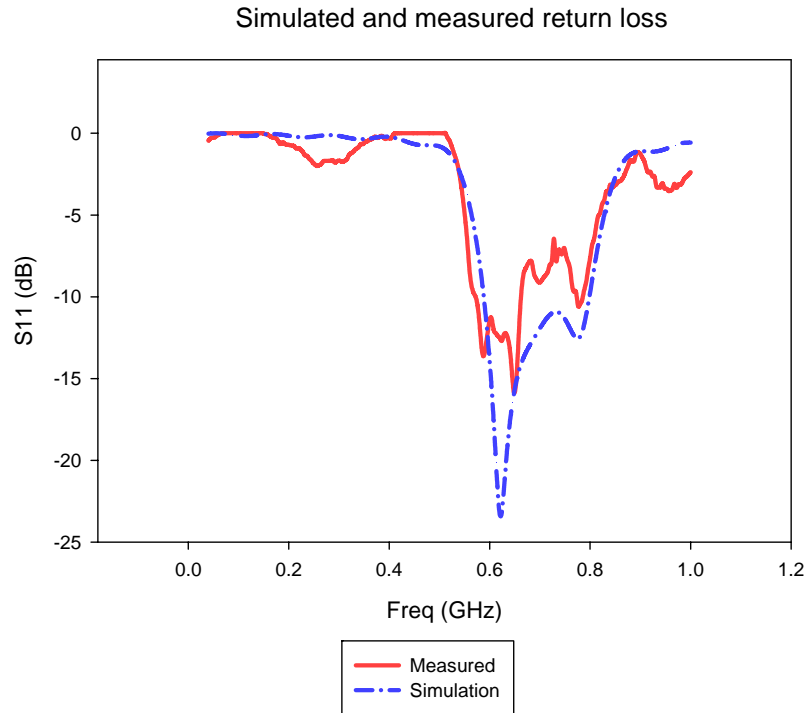

Figure 4.10: Measurement and simulation return loss of fractal Koch dipole array

Figure 4.10 shows the simulated and measured return loss of the proposed designed. The return loss was measured using Vector Impedance Analyzer VIA Echo. From the graph, it can be seen that result for both simulated and measured exhibit similar characteristic which have same frequency range covered from 570 MHz until 810 MHz with a return loss magnitude less than -10dB.

#### 4.2.2 Radiation Pattern Measurement Results

The radiation pattern measurement was done for the folded straight dipole, modified folded Koch dipole and fractal Koch dipole array antenna. For the folded straight dipole, the measurement is set at the resonant frequency of 815

MHz as it gave the best return loss value for this antenna. The measurement is done twice, first to measure the E-Field co-polarization (E-co), and the second one to measure the cross-polarization (E-cross). The result shows that the E-cross curve is much smaller than the E-co, which is a characteristic of a linear polarized antenna which is true for a dipole antenna. The E-Co in Figure 4.11 and the H-Co in Figure 4.12 shows that along the axis adjacent to the board, the power value is minimum; this is because in this angle none of the conductor on the board is facing the transmitting antenna.

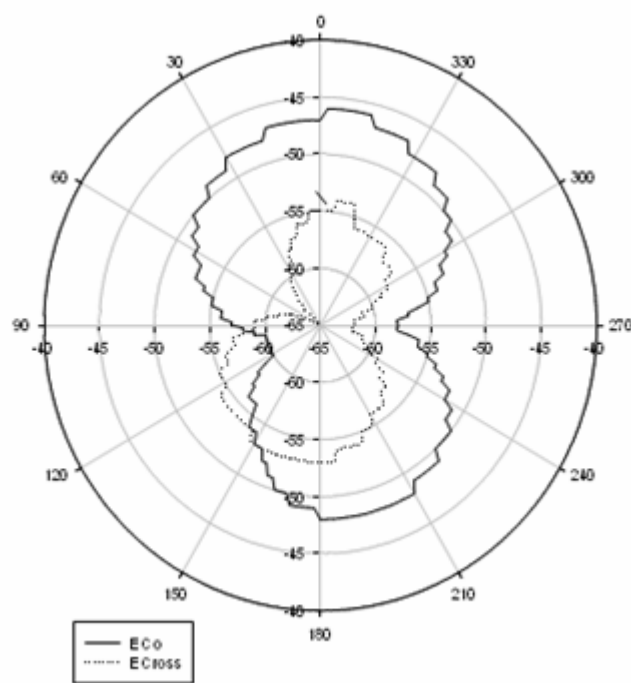

Figure 4.11: Measured radiation pattern for the E-Co and E-Cross of the folded straight dipole.



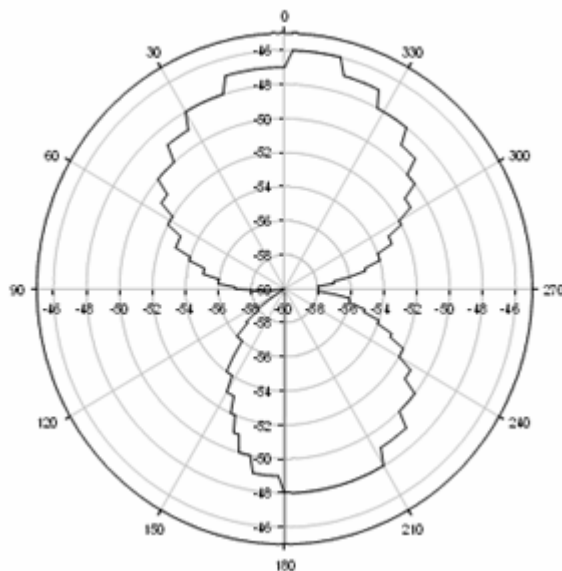

Figure 4.12: Measured radiation pattern for the H-Co of the folded Koch antenna

Figure 4.13 shows the radiation pattern measurement results for the folded modified Koch dipole. For this antenna, the measurement is set at the resonant frequency of 700 MHz as it gave the best return loss value for this antenna. The results in Figure 4.13 show that the E-cross curve is smaller than the E-co but not as small as for the folded straight dipole, which is towards a characteristic of a circular polarized antenna. Basically it is still a linear polarized antenna which is true for a dipole antenna. The shape of the pattern is more towards a circle, which is better than the folded straight line dipole in terms of omnidirectional because it radiates more uniformly to all directions. The H-Co in Figure 4.14 shows that along the axis adjacent to the board, the power value is minimum; this is because in this angle none of the conductor on the board is facing the transmitting antenna.

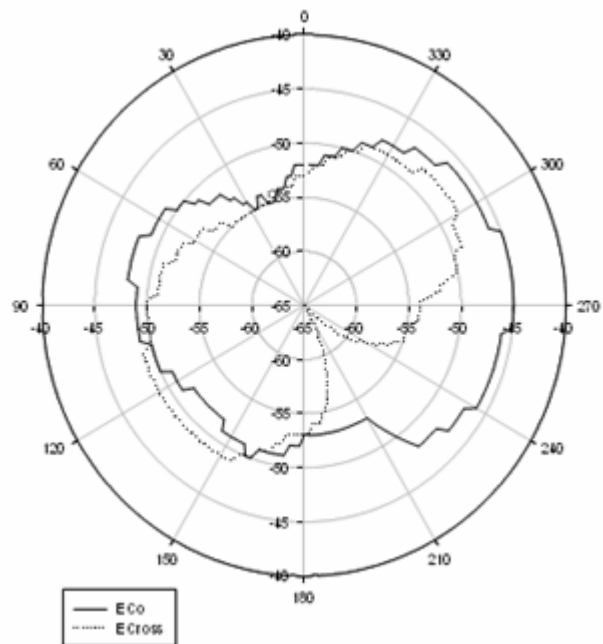

Figure 4.13: Measurement result for E-Co and E Cross of the folded Koch dipole

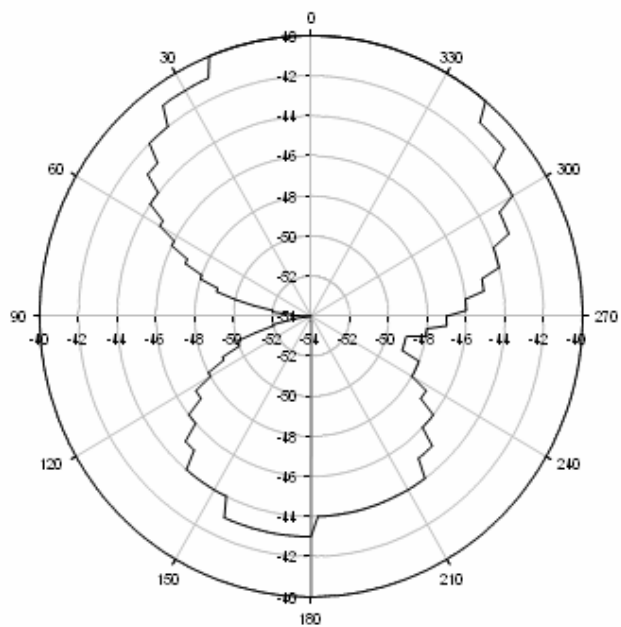

Figure 4.14: Measurement results for the H-Co radiation pattern of the folded Koch dipole

The measured radiation patterns for fractal Koch dipole array are shown in figure 4.15. From the measurement, the polarization of the antenna is linear polarization which is for E-plane, the cross polarization for E Co and E Cross roughly about 8 dB as well as for H plane. This antenna is omnidirectional pattern as can be seen at the polar plot. The radiation efficiency of this antenna is around 95%. This is considering a very good radiation at the particular frequency. The measured radiation patterns for H-Plane are depicted in figure 4.16 while figure 4.17 shows the E-co and H-Co plot. So, it can be seen that the antenna react same as a dipole characteristic

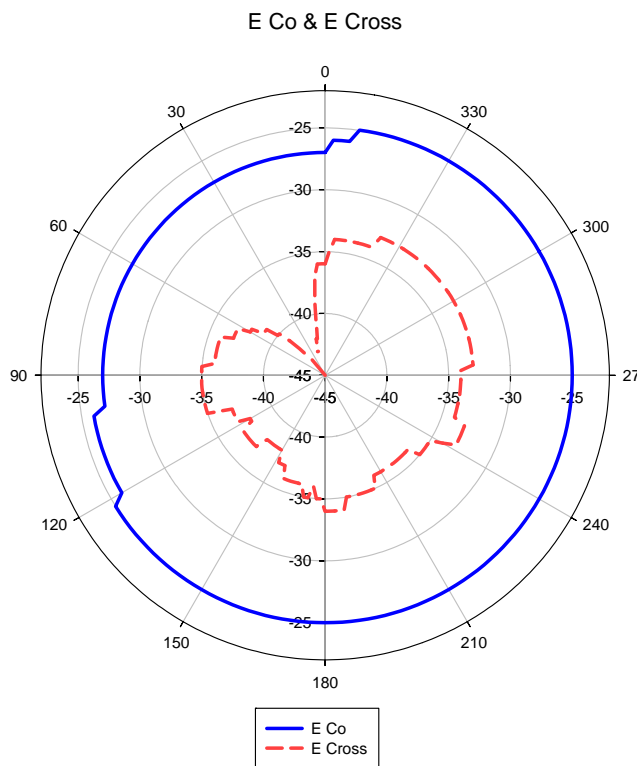

Figure 4.15: Measured radiation pattern for E-Plane of the fractal Koch dipole array

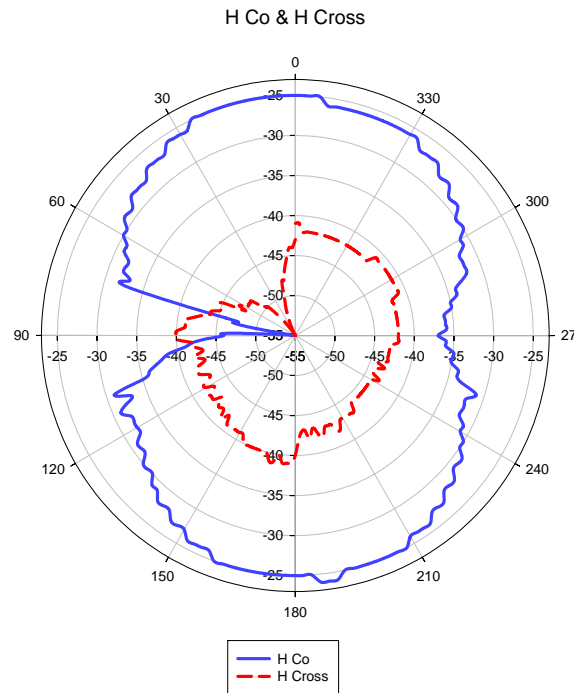

Figure 4.16: Measured radiation pattern for H- Plane of the fractal Koch dipole array

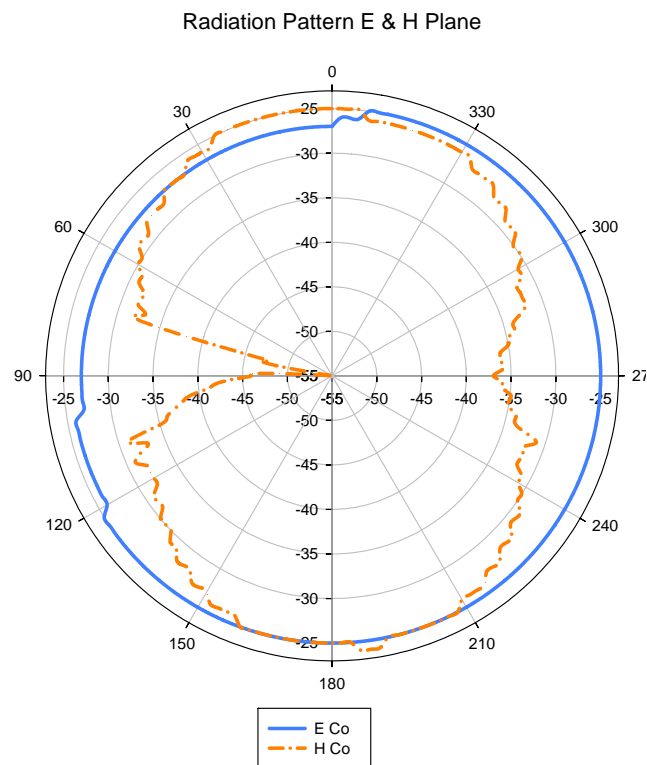

Figure 4.17: Measured Co & Cross Polar of the fractal Koch dipole array

### 4.3 Summary

This chapter has presented the simulation results of all designed antenna and the measurement results of the fabricated antennas that serve the purpose of the project. Both simulation and measurement for the return loss shows similar results with a slightly shift of resonant frequency. The bandwidth of the fabricated antenna is 7% which is quite small compared to the terrestrial TV frequency band. Although the radiation pattern did not exactly resemble the theoretical pattern, but it still shows a characteristic of a dipole antenna which is omnidirectional.

## **CHAPTER 5**

### **CONCLUSION AND FUTURE WORK**

#### **5.0 Conclusion**

The design of the planar dipole fractal antenna for the UHF band has been presented. The work includes designing, simulating, fabricating, and measuring the return loss and radiation pattern of the proposed antenna has been done. The designing process is based on different designs that have been proposed in published journals. The design and simulation is done using simulation software such as Applied Wave Research AWR, Agilent ADS 2004A and Computer Simulation Technology CST. Simulation is done to help the user know the predicted properties of the antenna before fabricating the antenna since only little calculations from literatures are provided for this kind of antenna. The fabrication involves photolithography and wet etching which gives adequate result for this type of antenna.

The simulation gives a bandwidth value of 5 % and the measurement gives a bandwidth value of 7 % which is quite small compared to the terrestrial TV frequency band. The simulation of the radiation pattern gives an omnidirectional pattern while the measurement does not quite give an omnidirectional pattern (the power is not the same in all direction) but it still radiates to all directions.

The folded dipole configuration can be used to increase bandwidth of a standard dipole.

The Koch fractal can be used to miniaturize the length of a standard straight line dipole.

The Koch fractal can be used to miniaturize the length of a standard straight line dipole.

The fractal Koch dipole array can be used to reduce the length of the straight dipole and also to increase the bandwidth.

## **5.1 Proposed Future Work**

Further works should be carried out in order to improve the bandwidth of the antenna:

1. Different configuration can be used such as the log periodic to get multiresonant frequencies to achieve wider bandwidth. But these methods will result a quite large dimension antenna.
2. Different kinds of dimension of the dipole arms can be experimented to find the optimum values for wider bandwidth.
3. Using a different kind of planar structure such as the single side planar with surrounding ground plane could give a better bandwidth.

## REFERENCES

1. Puente, C., Romeu, J., Pous, R., Ramis, J., and Hijazo, A. (1998) . Small But Long Koch Fractal Monopole. *IEEE Electronic Letters*, 34(1): 9-10.
2. Breden, R., and Langley, R.J. (1999). Printed Fractal Antennas. *IEEE National Conference on Antennas and Propagation*. pp. 1-4.
3. Stutzmann, Warren L. and Thiele, Garry A. *Antenna Theory and Design*. 2<sup>nd</sup> Ed. New York: John Wiley and Sons. 1998.
4. Johnson, H. and Graham, M. *High-Speed Digital Design*. New Jersey: Prentice-Hall. 1993.
5. Vinoy, K. J., Abraham, J.K., and Varadan, V.K. (2003). On the Relationship Between Fractal Dimension and the Performance of Multi-Resonant Dipole Antennas Using Koch Curves. *IEEE Transactions on Antennas and Propagation*. 51(9).
6. Chen, H.M., Chen, J.M., Chengand, P.S., and Lin, Y.F. (2004) . Feed for dual-band printed dipole antenna. *Electronics Letters*. 40(21).
7. Puente, C., Romeu, J., and Cardama, A. (2000). The Koch Monopole: A Small Fractal Antenna. *IEEE Transactions On Antennas And Propagation*. 48(11).



8. Wemer, D. , Haupt, R.L., and Wemer, P.L. ( 1999). Fractal antenna engineering: The theory and design of fractal antenna arrays. *IEEE Antennas and Propagation Magazine*. 41(5):37-59.
9. Best, S.R. (2002). On the resonant properties of the Koch fractal and other wire monopole antennas. *IEEE Antennas and Wireless Propagation Letters*. 1(1).
11. Best, S.R. (2003). A discussion on the significance of geometry in determining the resonant behavior of fractal and other non-Euclidean wire antennas. *IEEE Antennas and Propagation Magazine*, 45(3)9-28.
12. Vinoy, K. J., Abraham, J.K., and Varadan, V.K. (2003). Fractal dimension and frequency response of fractal shaped antennas. *IEEE Antennas and Propagation Society International Symposium*. 22-27 June. Volume 4 ,222 – 225 .
13. Werner, D.H., and Ganguly, S. (2003). An overview of fractal antenna engineering research. *IEEE Antennas and Propagation Magazine*. 45(1):38 - 57.
14. Eason, S.D., Libonati, R., Culver, J.W., Werner, D.H., Werner, P.L., and Mummareddy, S. (2001). UHF fractal antennas. *IEEE Antennas and Propagation Society International Symposium*. 8-13 July. Volume 3, 636 – 639.
15. Tang, P. (2001). Scaling property of the Koch fractal dipole. *IEEE Antennas and Propagation Society International Symposium* . 8-13 July. Volume 3, 150 – 153.
16. Breden, R., and Langley, R.J. (1999). Printed fractal antennas. *IEEE National Conference on Antennas and Propagation*. March-1 April. Page(s):1– 4,

17. An Hongming, Nauwelaers, B.K.J.C., and Van de Capelle, A.R. (1994). Broadband active microstrip antenna design with the simplified real frequency technique. *IEEE Transactions on Antennas and Propagation*. 42(12):1612 - 1619.
18. Suh, Young-Ho, and Chang, Kai. (2000). Low cost microstrip- fed dual frequency printed dipole antenna for wireless communications. *IEEE Electronics Letters*, 36(14):1177 - 1179.
19. Cohen, N. (1996). Fractal and shaped dipoles. *Commun. Quart.*,25–36.
20. Karnfelt, C., Hallbjorner, P., Zirath, H., and Alping, A. (2006). High gain active microstrip antenna for 60-GHz WLAN/WPAN applications. *IEEE Transactions on Microwave Theory and Techniques*. 54(6):2593 – 2603.
21. Li, J. (1993). Direction and polarization estimation using arrays with small loops and short dipoles. *IEEE Transactions on Antennas and Propagation*. 41(3) :379 - 387.
22. Sarabandi,K. and Azadegan, R. (2003). Design of an efficient miniaturized UHF planar antenna. *IEEE Transactions on Antennas and Propagation*. 51(6) :1270 -1276.
23. Hsiao,Fu-Ren and Wong, Kin-Lu (2004). Omnidirectional planar folded dipole antenna. *IEEE Transactions on Antennas and Propagation*. 52(7):1898 – 1902.

## APPENDIX A

### Marconi Microwave Test Set 6204 Specification



- Precision Scalar Network Measurements
- Frequency Range: 10Mhz to 46Ghz
- Real Time Fault Location With 0.1% accuracy
- Economical, Compact & Portable
- Number Of Inputs - Four (A, B, C and D)
- Detection Modes - AC and DC
- Measurement Points - User selectable from 2 to 1601
  - Number Of Channels : Two channels, two measurements may be made per channel allowing a total of four simultaneous measurements

### APPENDIX B



### Vector Impedance Analyzer

#### Via Echo's Measurement

|               |                  |
|---------------|------------------|
| ▪ SWR         | ▪ Gamma Magnitud |
| ▪ Return Loss | ▪ Gamma Agnle    |
| ▪ Impedance   | ▪ Linear Gain    |
| ▪ Phase Angle | ▪ Log Gain       |
| ▪ Reactance   | ▪ Phase Gain     |

## APPENDIX C

### FR4 AND COMPOSITE PRE-SENSITISED PCB LAMINATES

High quality dip coated positive working photoresist. This high resolution photoresist contains a dye which gives a good contrast against the copper, allowing boards to be easily inspected at the developing stage. Panels are protected by a specially designed light-proof blue film which allows them to be guillotined without the risk of fracturing the Photoresist.

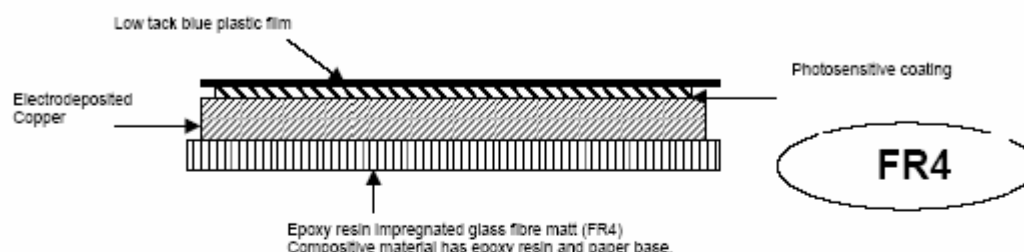

|                                    | FR4 Laminate  |
|------------------------------------|---|
| Thickness                          | 1.6mm   |
| Copper foil                        | 35 microns  |
| Dissipation factor                 | 35  |
| Dielectric Constant                | 5.4   |
| Solderbath resistance (260°)       | 20 secs.  |
| Resist thickness                   | 5 microns   |
| Spectral response                  | 350 – 450 nm  |
| U.V. light energy required approx. | 50ml / cm   |
| Shelf life                         | 1 year at 15 – 20°C                                       |
| Developer                          | 3204996   |
| Etchant                            | Ferric Chloride Pellets or liquid and Fine Etch Crystals. |

#### U.V. EXPOSURE

Use a good quality artwork and purpose made U.V. exposure unit. The exact exposure time will vary, depending on the quality of the artwork used and the size of the U.V. unit. As a guide: Exposure times between 90 seconds and 120 seconds are normally sufficient.

#### DEVELOPING THE RESIST

Use 3204996 Developer concentrate. Mix as instructed and use between 18°C – 24°C, preferably in a heated Processing Tank (157363). Developing time will depend on artwork, exposure and developer temperature, 30 seconds to 180 seconds is typical.

Ready to use 141-310 Developer can also be used with this board, but the above mentioned 3204996 is recommended as the preferred developer.

---

#### FARNELL ELECTRONIC COMPONENTS LIMITED.

CANAL ROAD, LEEDS, WEST YORKSHIRE, LS12 2TU

Telephone Number: 0113263 6311

Fax Number: 0113263 3411

## APPENDIX D

## Radiation Pattern Measurement Setup

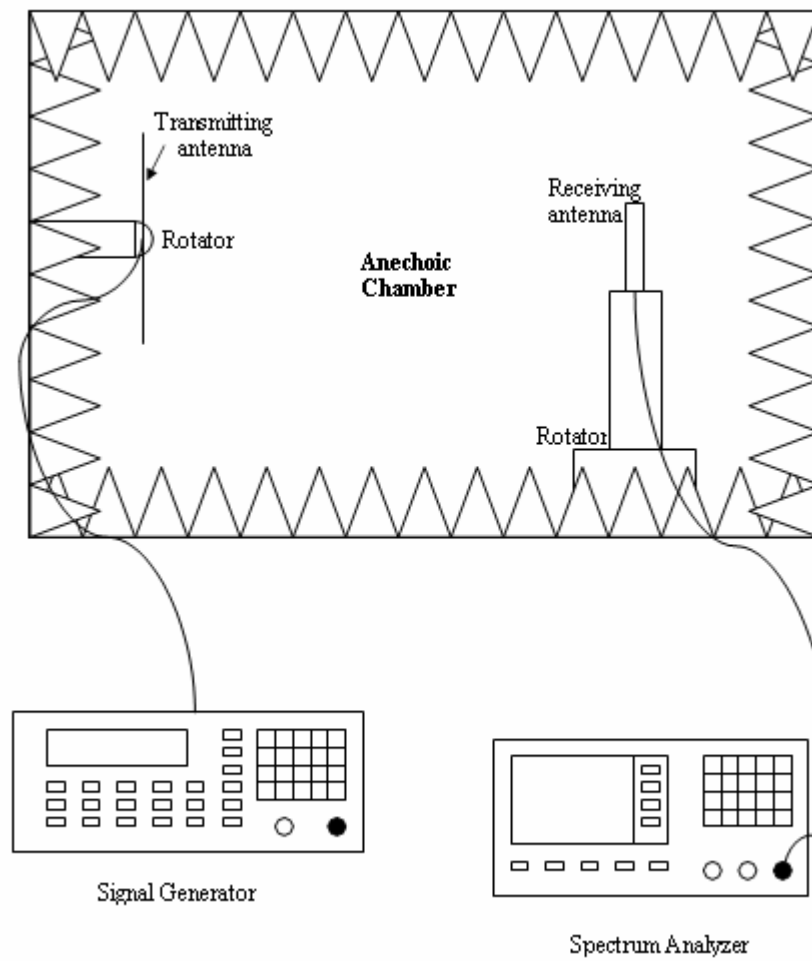

**UNIVERSITI TEKNOLOGI MALAYSIA**  
**Research Management Centre**

**PRELIMINARY IP SCREENING & TECHNOLOGY ASSESSMENT FORM**

*(To be completed by Project Leader submission of Final Report to RMC or whenever IP protection arrangement is required)*

**1. PROJECT TITLE IDENTIFICATION :**

**DESIGN AND DEVELOPMENT OF FRACTAL ANTENNA FOR UHF BAND APPLICATION**

Vote No: 79018

**2. PROJECT LEADER :**

Name : PROF. MADYA DR. MOHAMAD KAMAL A. RAHIM

Address : JABATAN KEJURUTERAAN RADIO, FAKULTI KEJURUTERAAN ELEKTRIK,  
UNIVERSITI TEKNOLOGI MALAYSIA, 81310 SKUDAI, JOHOR

Tel : 07 5536088

Fax : - 07-5566272

e-mail : mkamal@fke.utm.my

**3. DIRECT OUTPUT OF PROJECT** *(Please tick where applicable)*

| Scientific Research                            | Applied Research  | Product/Process Development                    |
|--|---|--|
| <input type="checkbox"/> Algorithm             | <input type="checkbox"/> Method/Technique                     | <input type="checkbox"/> Product / Component   |
| <input type="checkbox"/> Structure             | <input checked="" type="checkbox"/> Demonstration / Prototype | <input type="checkbox"/> Process               |
| <input type="checkbox"/> Data                  |   | <input type="checkbox"/> Software              |
| <input type="checkbox"/> Other, please specify | <input type="checkbox"/> Other, please specify                | <input type="checkbox"/> Other, please specify |
| _____  | _____   | _____  |
| _____  | _____   | _____  |
| _____  | _____   | _____  |

**4. INTELLECTUAL PROPERTY** *(Please tick where applicable)*

- |  |  |
|--|--|
| <input type="checkbox"/> Not patentable                    | <input type="checkbox"/> Technology protected by patents |
| <input checked="" type="checkbox"/> Patent search required | <input type="checkbox"/> Patent pending                  |
| <input type="checkbox"/> Patent search completed and clean | <input type="checkbox"/> Monograph available             |
| <input type="checkbox"/> Invention remains confidential    | <input type="checkbox"/> Inventor technology champion    |
| <input type="checkbox"/> No publications pending           | <input type="checkbox"/> Inventor team player            |
| <input type="checkbox"/> No prior claims to the technology | <input type="checkbox"/> Industrial partner identified   |

**5. LIST OF EQUIPMENT BOUGHT USING THIS VOT**

- Computer Simulation Technology (CST) and AWR Microwave Office (Rental)
  - Handheld Spectrum Analyzer (UP TO 3 GHz)
  - Handheld Vector Impedance Analyzer (Via Eco)
- 
- 

**6. STATEMENT OF ACCOUNT**

|    |                  |                 |
|----|------------------|-----------------|
| a) | APPROVED FUNDING | RM : 176,796.00 |
| b) | TOTAL SPENDING   | RM : 176,681.49 |
| c) | BALANCE          | RM : 114.51     |

**7. TECHNICAL DESCRIPTION AND PERSPECTIVE**

*Please tick an executive summary of the new technology product, process, etc., describing how it works. Include brief analysis that compares it with competitive technology and signals the one that it may replace. Identify potential technology user group and the strategic means for exploitation.*

## a) Technology Description

This project begins with understanding the concept of the planar structure antenna technologies and Fractal antenna behavior . This includes the properties such as radiation pattern, input impedance, bandwidth, beamwidth and operating frequency. The design and simulation has been carried out using comercial software ie: Computer Simulation Technology CST and Applied Wave Research AWR. The practical implementation has been carried out after the simulation process completed. The comparisons between simulation and experimental have been made in term of return loss, bandwidth and radiation pattern. It shows that the fractal UHF antenna can be reduced the size of planar dipole antenna by 20 percent from the original planar structure.

## b) Market Potential

Suitable for wireless industries that operating in the UHF band application.

---



c) Commercialisation Strategies

This product suitable for UHF band application. So, for the commercialization need some extra work and funding for final packaging of the product.

---



---



---

**8. RESEARCH PERFORMANCE EVALUATION**

a) FACULTY RESEARCH COORDINATOR

|                 |           |           |      |              |      |      |
|-----------------|-----------|-----------|------|--------------|------|------|
| Research Status | ( )       | ( )       | ( )  | ( )          | ( )  | ( )  |
| Spending        | ( )       | ( )       | ( )  | ( )          | ( )  | ( )  |
| Overall Status  | ( )       | ( )       | ( )  | ( )          | ( )  | ( )  |
|                 | Excellent | Very Good | Good | Satisfactory | Fair | Weak |

Comment/Recommendations :

---



---



---



---



---

.....  
 Signature and stamp of  
 JKPP Chairman

Name : .....  
 Date : .....

b) RMC EVALUATION

|                 |           |           |      |              |      |      |
|-----------------|-----------|-----------|------|--------------|------|------|
| Research Status | ( )       | ( )       | ( )  | ( )          | ( )  | ( )  |
| Spending        | ( )       | ( )       | ( )  | ( )          | ( )  | ( )  |
| Overall Status  | ( )       | ( )       | ( )  | ( )          | ( )  | ( )  |
|                 | Excellent | Very Good | Good | Satisfactory | Fair | Weak |

Comments :-

---



---



---



---



---



---

Recommendations :

- Needs further research
- Patent application recommended
- Market without patent
- No tangible product. Report to be filed as reference

.....  
 Signature and Stamp of Dean /  
 Deputy Dean  
 Research Management Centre

Name : .....

Date : .....

## End of Project Report For ScienceFund

|  |  |
|--|--|
| <b>A. Description of the Project</b>   |  |
| 1. <b>Project number:</b>  | 79018  |
| 2. <b>Project title:</b>   | DESIGN AND DEVELOPMENT OF FRACTAL ANTENNA FOR UHF BAND APPLICATION   |
| 3. <b>Project leader:</b>  | Assoc. Prof Dr Mohamad Kamal A Rahim   |
| 4. <b>Project Team:</b>  | (Please provide an assessment of how the project team performed and highlight any significant departures from plan in either structure or actual man-days utilised)<br><br>Assoc. Prof. Dr. Mohammad Kamal A. Rahim<br>Mr Nazri A. Karim<br>Mr. Thelaha Masri<br>Mr Huda A. Majid<br>Mr Osman Ayop |
| 5. <b>Industrial Partnership:</b>  | (Please describe the nature of collaborations with relevant industry)<br>At this moment, no collaborations with relevant industries involve.   |
| 6. <b>National/International Collaboration</b>   | (please identify research organisations and describe the nature of collaboration)<br>No research organisation involve.   |
| 7. <b>Project Duration:</b> ____21____ months  |  |
| 8. <b>Budget Approved:</b> RM 176,769.00   |  |
| <b>B. Objectives of the project</b>  |  |
| <b>1. Socio-economic Objectives (SEO)</b>  |  |
| Which socio-economic objectives are addressed by the project? (Please identify the Research Priority Area , SEO Category and SEO Group under which the project falls. Refer to the Malaysian R&D Classification System, 4 <sup>th</sup> Edition. |  |
| Research Priority Area   |  |
| SEO Category:  | <u>Information Communication and Technology (ICT)</u>  |
| SEO Group :  | <u>Communication Sevicees</u>  |
| <b>2. Fields of Research (FOR)</b>   |  |
| Which are the two main FOR Categories, FOR Groups, and FOR Areas of your project? (Please refer to the Malaysian R&D Classification System, 4 <sup>th</sup> Edition)   |  |
| a. Primary field of research   |  |
| FOR Category:  | <u>Information Communication and Technology (ICT)</u>  |
| FOR Group :  | <u>Communication</u>   |
| FOR Area:  | <u>Antenna Technology</u>  |
| b. Secondary Field of research   |  |
| FOR Category:  | <u>Information Communication and Technology (ICT)</u>  |
| FOR Group :  | <u>Communication</u>   |
| FOR Area:  | <u>Wireless Communication and Technologies</u>   |

**C. Objectives achievement**

- **Original project objectives** (Please state the specific project objectives as described in Section II of the Application Form)
  1. To design and develop a new structure of fractal antenna design for multiband operating frequency.
  2. To develop a prototype fractal antenna for Ultra High Frequency Wireless RAN technology

- **Objectives Achieved** (Please state the extent to which the project objectives were achieved)

New structure of fractal antenna has been successfully designed and fabricated operating at UHF band application. The prototyped of this antenna has been tested and verify with the simulation using CST software.

- **Objectives not achieved** (Please identify the objectives that were not achieved and give reasons)

**D. Technology Transfer/Commercialisation Approach, if any.** (Please describe the approach planned to transfer/commercialise the results of the project)

A new structure of Fractal antenna has been successfully designed and fabricated. For a commercialisation approach, it's need some extra work in a market planning and need some funding for that task.

**E. Assessment of Research Approach** (Please highlight the main steps actually performed and indicate any major departure from the planned approach or any major difficulty encountered)

According to the project schedule.

**F. Assessment of the Project Schedule** (Please make any relevant comment regarding the actual duration of the project and highlight any significant variation from plan)

Project folllow as schedule

**G. Assessment of Project Costs** (Please comment on the appropriateness of the original budget and highlight any major departure from the planned budget)

According to the buddget given.

**H. Additional Project Funding Obtained** (In case of involvement of other funding sources, please indicate the source and total funding provided)

No additional funding.

**I. Benefits of the Project** (Please identify the actual benefits arising from the project as defined in Section III of the Application Form. For examples of outputs, organisational outcomes and sectoral/national impacts, please refer to Section III of the Guidelines for the Application of R&D Funding under ScienceFund)

Prototype of the antenna operating at UHF band using planar structure.

**1. Direct Outputs of the Project** (please describe as specifically as possible the outputs achieved and provide an assessment of their significant to users)

**i. Technical contribution of the project**

**a. What was the achieved direct output of the project:**

For basic oriented research projects ?

Algorithm

Structure

Data

Other, please specify: \_\_\_\_\_

For applied research (technology development) projects:

- Method/technique
- Demonstrator/prototype  
Antenna Prototype operating at UHF band.

- Product/component
- Process
- Software
- Other, please specify:

**b. How would you characterise the quality of this output?**

- Significant breakthrough
- Major improvement
- Minor improvement

**ii. Contribution of the project to knowledge**

**a. How has the output of the project been documented?**

- Detailed project report
- Product/process specification documents
- Other, please specify: Papers publication

**b. Did the project create an intellectual property stock?**

- Patent obtained
- Patent pending
- Patent application will be filed
- Copyright

**c. What publications are available?**

- Articles (s) in scientific publications                      How many: \_\_\_\_\_
- Paper(s) delivered at conferences/seminars                      How many: 2 papers
- Book
- Other, please specify:

**d. How significant are citations of the results?**

- Citations in national publications                      How many: \_\_\_\_\_
- Citations in international publications                      How many: \_\_\_\_\_
- None yet
- Not known

**2. Organisational Outcomes of the Project** (Please describe as specifically as possible the organisational benefits arising from the project and provide an assessment of their significance)

**i. Contribution of the project to expertise development**

**a. How did the project contribute to expertise?**

- PhD degrees                      How many: \_\_\_\_\_
- MSc degrees                      How many: 2
- Research staff with new specialty                      How many: \_\_\_\_\_
- Other, please specify: \_\_\_\_\_

**b. How significant is this expertise?**

- One of the key areas of priority for Malaysia (ICT Research Area)
- An important area, but not a priority one

**ii. Economic contribution of the project?**

**a. How has the economic contribution of the project materialised?**

- Sales of manufactured product/equipment
- Royalties from licensing
- Cost savings
- Time savings
- Other, please specify: \_\_\_\_\_

**b. How important is this economic contribution?**

- High economic contribution                      Value: RM \_\_\_\_\_
- Medium economic contribution                      Value: RM -
- Low economic contribution                      Value: RM \_\_\_\_\_

**c. When has this economic contribution materialised?**

- Already materialised
- Within months of project completion
- Within three years of project completion
- Expected in three years or more
- Unknown

**iii. Infrastructural contribution of the project**

**a. What infrastructural contribution has the project had?**

- New equipment (Spectrum & Eco analyzer) Value: RM 59 000.00 \_\_\_\_\_
- New/improved facility Investment: RM \_\_\_\_\_
- New information networks
- Other, please specify: \_\_\_\_\_

**b. How significant is this infrastructural contribution for the organisation?**

- Not significant/does not leverage other projects
- Moderately significant
- Very significant/significantly leverages other projects

**iv. Contribution of the project to the organisation's reputation**

**a. How has the project contributed to increasing the reputation of the organisation**

- Recognition as a Center of Excellence
- National award
- International award
- Demand for advisory services
- Invitations to give speeches on conferences
- Visits from other organisations
- Other, please specify: \_\_\_\_\_

**b. How important is the project's contribution to the organisation's reputation?**

- Not significant
- Moderately significant
- Very significant

**3. National Impacts of the Project** (If known at this point in time, please describe as specifically as possible the potential sectoral/national benefits arising from the project and provide an assessment of their significance)

**i. Contribution of the project to organisational linkages**

**a. Which kinds of linkages did the project create?**

- Domestic industry linkages
- International industry linkages
- Linkages with domestic research institutions, universities
- Linkages with international research institutions, universities

**b. What is the nature of the linkages?**

- Staff exchanges
- Inter-organisational project team
- Research contract with a commercial client
- Informal consultation
- Other, please specify: \_\_\_\_\_

**ii. Social-economic contribution of the project**

**a. Who are the direct customer/beneficiaries of the project output?**

Customers/beneficiaries:

Wireless industries / wireless subscriber

Number:

To all wireless communication industries using UHF band.

**b. How has/will the socio-economic contribution of the project materialised?**

- Improvements in health
- Improvements in safety
- Improvements in the environment
- Improvements in energy consumption/supply



Improvements in international relations

Other, please specify: Improvement in wireless engineering knowledgement

**c. How important is this socio-economic contribution?**

High social contribution

Medium social contribution

Low social contribution

**d. When has/will this social contribution materialised?**

Already materialised

Within three years of project completion

Expected in three years or more

Unknown

**Date:** 12 August 2008

**Signature:**

