

The Use of Reflection Mode Ultrasonic Transceiver Sensor in Pipeline Inspection Gauge to Monitor Pipeline Internal Corrosion

M. Azreen Firdaus Abd Aziz^a, Mariani Idroas^{a*}, Zainal Zakaria^a, A. Ridhwan Md Zin^b, M. Nasir Ibrahim^b

^aFaculty of Petroleum and Renewable Energy Engineering, Universiti Teknologi Malaysia, 81310 UTM Johor Bahru, Johor, Malaysia

^bFaculty of Electrical Engineering, Universiti Teknologi Malaysia, 81310 UTM Johor Bahru, Johor, Malaysia

*Corresponding author: mariani@petroleum.utm.my

Article history

Received :5 February 2014

Received in revised form :

7 April 2014

Accepted :20 May 2014

Graphical abstract

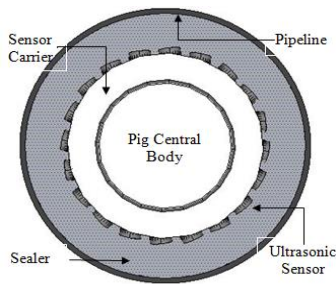

Abstract

Aging gas transmission pipelines are prone to internal corrosion due to the presence of carbon dioxide and hydrogen sulphide in the natural gas constituents. Commonly, the in-line inspection tool known as Pipeline Inspection Gauge (PIG) is applied to perform the corrosion inspection of the pipeline. This paper describes an ultrasonic instrumentation system for PIG to monitor internal corrosion of pipeline. The system consists of ultrasonic transceiver sensor, ultrasonic driving circuitry and data acquisition system. The hardware is equipped with a sensor carrier which is propelled along the test pipeline. The time of flight (TOF) of the ultrasonic wave is measured and was used to evaluate the internal corrosion of pipeline. An initial experimental instrument was set up to perform the distance measurement test at a frequency of 390 kHz, to simulate the changes of pipe wall thickness due to corrosion effect. Surface anomalies were created at different positions to simulate the changes of pipe wall thickness due to the corrosion effect. Variation in measured distances implied the existence of the surface anomalies. The results of the simulated surface anomalies showed that the percentage error was less than $\pm 5\%$. The large value of average DC voltage gave indication of distance increment due to the depth of the surface anomalies. The developed ultrasonic instrumentation system is capable to monitor the internal corrosion of pipeline.

Keywords: Corrosion; pipeline; pipe inspection; ultrasonic; transceiver sensor

© 2014 Penerbit UTM Press. All rights reserved.

1.0 INTRODUCTION

Natural gas is commonly transported via the pipeline system for long distance transportation since it is the most effective way [1]. Technically, there are two types of operating system for the pipeline transportation which is transmission pipeline and distribution pipeline [2]. A transmission pipeline system will transport the natural gas at a very high pressure from the Gas Processing Plant (GPP) to the distribution centre [3].

Transmission pipeline is made from carbon steel and it is prone to the internal corrosion since the constituents of the natural gas consist of hydrate components such as hydrogen sulphide, carbon dioxide and chloride. These acidic gases have a very high potential to initiate and contribute the internal corrosion which will reduce the integrity of the pipeline. Internal corrosion problem may cause a leakage to the pipe wall and thus produce negative impacts towards the economic issues, environmental condition and human loss [4].

Application of in-line inspection or usually known as Intelligent Pipeline Inspection Gauge (PIG) is very common in the

oil and gas industry especially to monitor the integrity of the pipeline based on the Non Destructive (NDT) method [5]. Such Intelligent PIG available in the industry are Magnetic Flux Leakage (MFL) PIG, Eddy Current (EC) PIG, Electromagnetic Acoustic Transducer (EMAT) PIG and Ultrasonic PIG [6]. This paper describes the present work on the design of the ultrasonic instrumentation system for the PIG to monitor the pipeline's internal corrosion based on the ultrasonic signal. The system consists of ultrasonic transceiver sensors, driving circuit and data acquisition system.

The main concept applied to monitor the internal corrosion of the pipeline is based on the reflection of the ultrasonic wave. This phenomenon of ultrasonic wave's reflection is due to the acoustic impedance law [7]. The ultrasonic wave will emit from the sensor and it will propagate through the air medium. When the ultrasonic wave reach the internal pipe wall, a part of the ultrasonic wave will be reflected while the remaining of the wave will be transmitted [8]. The reflected ultrasonic wave will be received by the sensor. Figure 1 shows the illustration diagram on

the phenomenon of transmission and reflection of ultrasonic wave.

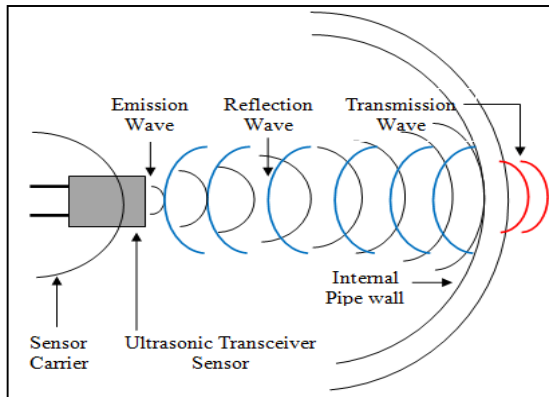

Figure 1 Transmission and reflection of ultrasonic wave

The time taken by the ultrasonic wave to propagate during the emission and received by the sensor is referred as Time of Flight (TOF). TOF data of the ultrasonic wave is utilized to determine the distance travelled by the ultrasonic wave. The data of TOF provides information on the distance between the sensor and the surface of the internal pipe wall and thus evaluate the existence of the pipeline’s internal corrosion. Equation (1) shows the relationship between the TOF of ultrasonic wave and the distance between the sensor and the internal pipe wall [9].

$$L = (TOF \times c)/2 \tag{1}$$

- L : distance between the sensor and internal pipe wall
- TOF : Time of Flight of the ultrasonic wave
- C : velocity of the ultrasonic wave in the air

Internal corrosion will cause a metal loss on the surface of the internal pipe wall. Therefore, the distance between the sensor and the pipe wall will be increased and this will influence the TOF value. Theoretically, internal corrosion will have a greater value of TOF while normal condition of pipe wall will have a uniform value of TOF. Figure 2 and Figure 3 show the differences on the distance between the sensor and internal pipe wall for normal and corroded pipe.

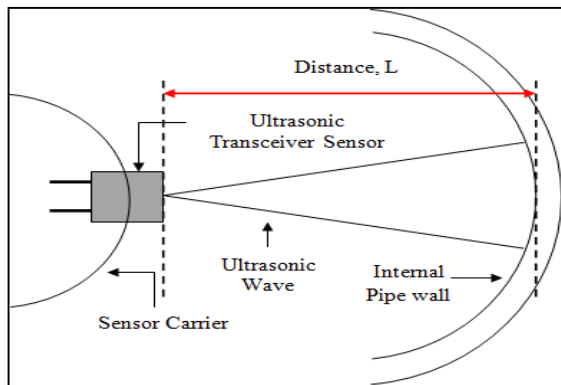

Figure 2 Schematic of cross correlation method to measure the velocity

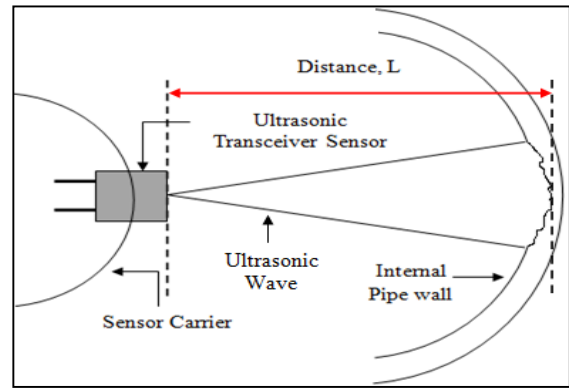

Figure 3 Schematic of cross correlation method to measure the velocity

2.0 METHODOLOGY

The developed Ultrasonic PIG will be propelled along the Perspex pipeline. The length of the pipeline is 2.00 metre and it is horizontal. The specification of the pipeline size is 250 mm for outside diameter and 240 mm for internal diameter with a wall thickness of 5 mm. The ultrasonic instrumentation system is installed in a specific compartment identified as a sensor carrier. All of the electronic components and devices are located in the sensor carrier. This sensor carrier is mechanically connected at the trailing part of the PIG body. The size of the PIG’s sealer is designed so that it is suitable to move along the pipeline.

The ultrasonic transceiver sensors are mounted surrounding the sensor carrier. There are 60 units of ultrasonic transceiver sensor used in the system. The arrangement of the sensor is fixed based on the modelling study in order to have full coverage of inspection area on the pipe wall. Figure 4 shows the distribution of the ultrasonic transceiver sensors on the sensor carrier from a rear view of the Pig body and Figure 5 shows the 2D drawing of Ultrasonic PIG. The overall instrumentation system is shown in Figure 6.

During the operation, the TOF for each sensor is monitored. The information of the TOF data will be further processed to evaluate the existence of the internal corrosion. Finally, the collected data will be processed to reconstruct the image of the internal corrosion.

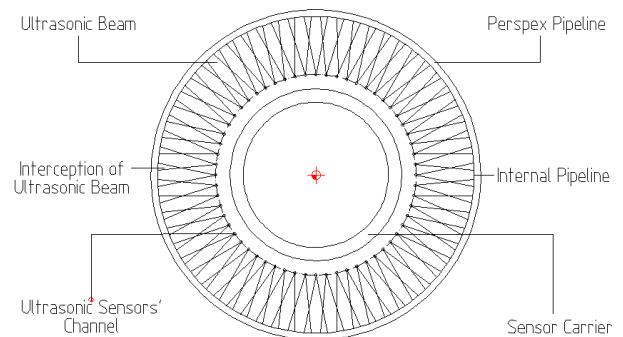

Figure 4 Arrangement of ultrasonic sensors

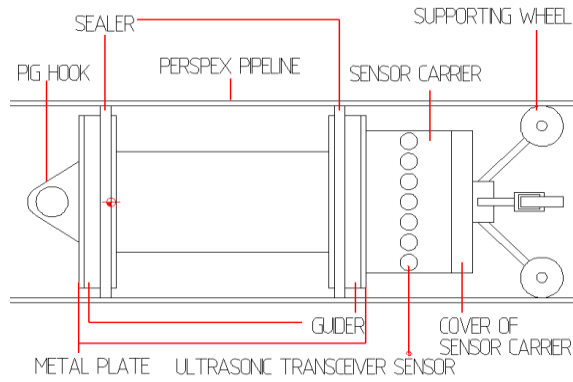

Figure 5 2D drawing of ultrasonic PIG

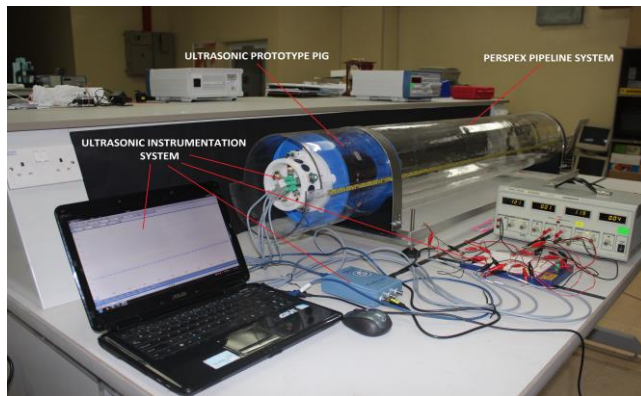

Figure 6 The overall instrumentation system

4.0 RESULTS AND DISCUSSIONS

An experimental test of distance measurement by the ultrasonic transceiver sensor has been conducted to observe the performance of the sensor. Generally, this experimental study utilizes ultrasonic transceiver sensor to measure a distance from the sensor to the Perspex plate. The position of the Perspex plate is varied in order to simulate the changes of the internal pipe wall thickness due to the corrosion effect. Model of ultrasonic transceiver used is a UB300-18GM40-I-V1 sensor in a module form. The frequency of the sensor is at 390 kHz and it has a narrow beam characteristic. In this experiment the minimum position of the Perspex plate from the sensor is 6 inch and it will be varied farther inch by inch (Figure 7).

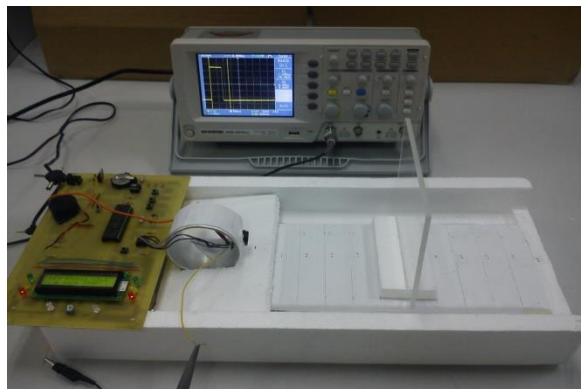

Figure 7 Experimental test on distance measurements

The position of the Perspex plate is varied begin from 6 inches until 15 inches from the ultrasonic transceiver sensor. Table 1 shows the result of the distance measurements.

Table 1 Distance measurements

Real Distance (inch)	Distance Measured, L (inch)				Percentage Error (%)
	1st Reading	2nd Reading	3rd Reading	Average Reading	
6	6.39	6.39	5.57	6.12	2.00
7	7.35	7.35	7.35	7.35	5.00
8	8.30	8.30	8.30	8.30	3.75
9	9.39	9.39	9.39	9.39	4.33
10	10.34	10.34	10.34	10.34	3.40
11	11.29	11.29	11.16	11.25	2.27
12	12.79	12.25	12.38	12.47	3.92
13	13.20	13.33	13.20	13.24	1.85
14	14.56	14.56	14.69	14.60	4.29
15	15.65	15.65	15.65	15.65	4.33

Three experiments are done at three different perimeters along the pipelines to monitor anomalies on internal pipeline surface. Figures 8 and 9 show the setup of three perimeters on the pipeline.



Figure 8 Three different perimeters setup on the Perspex pipeline system

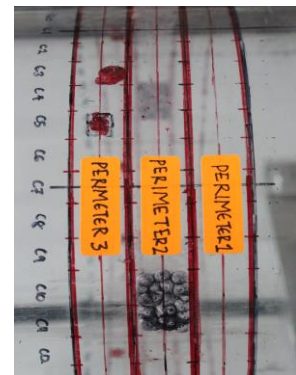

Figure 9 Layout of grid composition at each perimeter

Perimeter 1 represents normal internal pipeline surface, where the condition of the internal pipeline is clean without any surface

anomaly (Figure 10). Large internal pipelines surface anomalies are simulated at Perimeter 2 (Figure 11), while the small internal pipeline surface anomalies are simulated at Perimeter 3 (Figure 12).

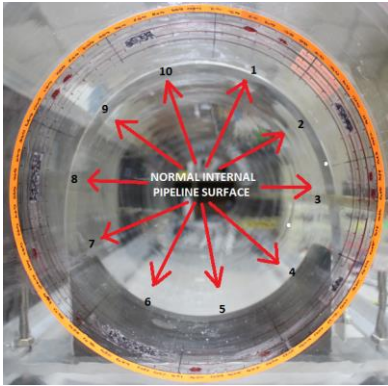

Figure 10 Perimeter 1 of normal internal pipeline surface

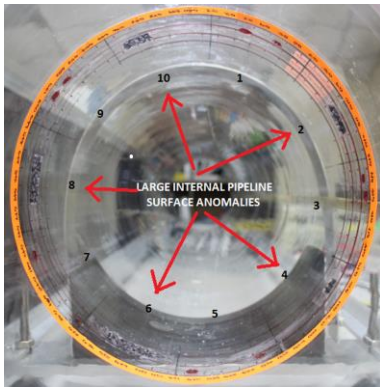

Figure 11 Perimeter 2 of large internal pipeline surface anomalies

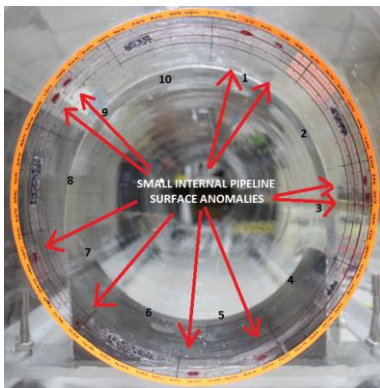

Figure 12 Perimeter 3 of small internal pipeline surface anomalies

The reconstructed images for the normal pipeline (without any anomaly), the pipeline with large surface anomalies and small surface anomalies are shown in Figures 13, 14 and 15, respectively.

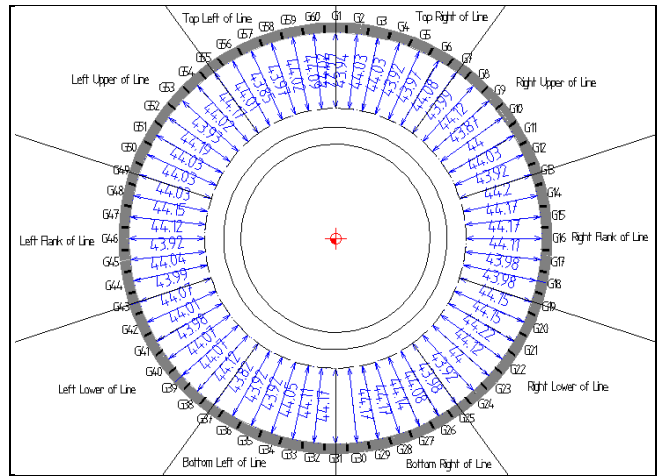

Figure 13 Image generation of Perimeter 1 (Normal internal pipeline surface)

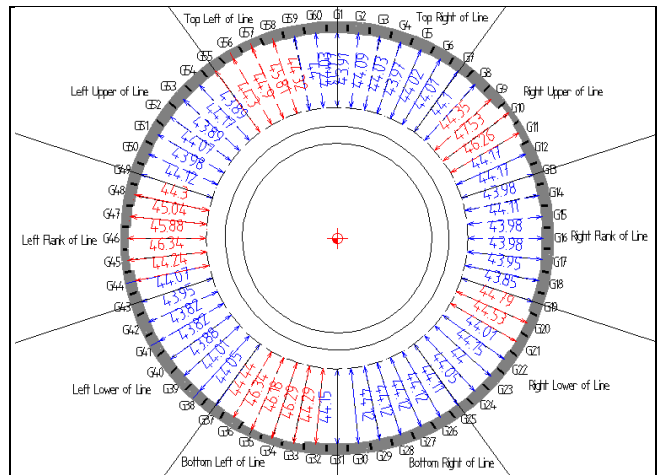

Figure 14 Image generation of Perimeter 2 (Large internal pipeline surface anomalies)

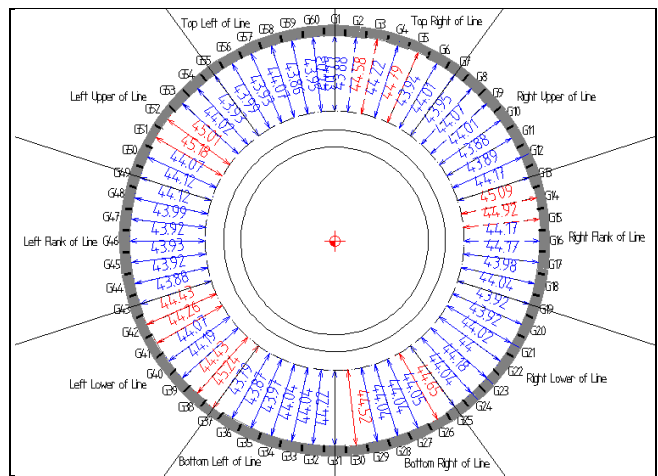

Figure 15 Image generation of Perimeter 3 (Small internal pipeline surface anomalies)

5.0 CONCLUSION

The results of the experiment show that the ultrasonic transceiver sensor has the capability to perform the distance measurement, with the percentage error below than 5 %. It can be seen that as the Perspex plate is placed farther from the ultrasonic transceiver sensor, the Time of Flight (TOF) is longer, indicating the distance is increased. The TOF data will indicate the existence of internal corrosion in the pipeline and it will be further processed to reconstruct the image of the internal corrosion. Basically, the effect of internal corrosion will cause a defect on the surface of internal pipe wall. In actual case, internal corrosion will cause metal loss degradation around 1 mm from the normal pipe wall thickness.

Acknowledgement

The authors would like to acknowledge the Ministry of Education and Universiti Teknologi Malaysia for the Geran Universiti Penyelidikan (GUP) and the support given.

References

- [1] Carvalho, A. A., J. M. A. Rebelo, et al. 2006. MFL Signals and Artificial Neural Networks Applied to Detection and Classification of Pipe Weld Defects. *NDT & E International*. 39(8): 661–667.
- [2] Mohitpour, M., J. Szabo, and T. Van Hardeveld. 2005. *Pipeline Operation & Maintenance: A Practical Approach*. ASME Press.
- [3] Folga, S. M. 2007. Natural Gas Pipeline Technology Overview, Argonne National Laboratory Technical Report ANL/EVS/TM/08-5.
- [4] Obanijesu, E.O., V. Pareek, M. O. Tade. 2010. Hydrate Formation and its Influence on Natural Gas Pipeline Internal Corrosion Rate. *Society of Petroleum Engineers Conference*. 128544-MS.
- [5] Bickerstaff, R., M. Vaughn, G. Stoker, M. Hassard, M. Garret. 2002. Review of Sensor Technologies for In-Line Inspection of Natural Gas Pipelines. *Pipes and Pipelines International*. 48 (1): 25–28.
- [6] Bubenik, T. A., J. B. Nestleroth, B. N. Leis. 2000. *Introduction to Smart Pigging in Natural Gas Pipelines*. Technical Report of the Gas Research Institute GRI-00/0247.
- [7] Raj, B., Jayakumar, T., Thavasimuthu, M. 2007. *Practical Non-Destructive Testing*. 3rd edition. Indira Gandhi Centre for Atomic Research Kalpakkam, India: Alpha Science.
- [8] Subramaniam, C. V. 2006. *Practical Ultrasonics*. Indira Gandhi Centre for Atomic Research Kalpakkam, India: Alpha Science.
- [9] Blitz, J. and Simpson, G. (1996), *Ultrasonic Methods of Non – Destructive Testing*. 1 st edition. University Press, Cambridge, United Kingdom.: Chapman & Hall.