

SUSTAINABLE DESIGN IMPROVEMENT FOR DIRECT-INDIRECT SEQUENCE OF AROMATIC SEPARATION PROCESS

INTRODUCTION

Distillation operations became a major concern within sustainability challenge, which it becomes a primary target of energy saving efforts in industrially developed countries. However, there is still one problem, which is how do we improve the energy efficiency of the existing distillation columns systems by considering the sustainability criteria without having major modifications. Recently, a new energy efficient distillation columns methodology that will able to improve energy efficiency of the existing separation systems without having major modifications has been developed. After all, this developed methodology was only considered the energy savings without taking into consideration the sustainability criteria.

OBJECTIVE

Objective of this study is to present new improvement of existing methodology by including a sustainability analysis to design an optimal sequence of energy efficient distillation columns.

RESEARCH METHODOLOGY

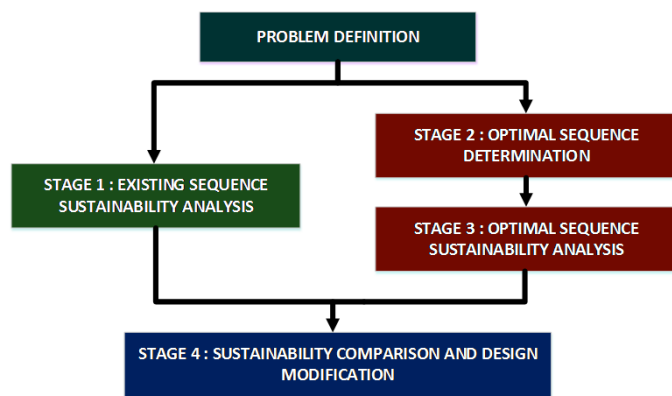

SUSTAINABILITY EVALUATOR

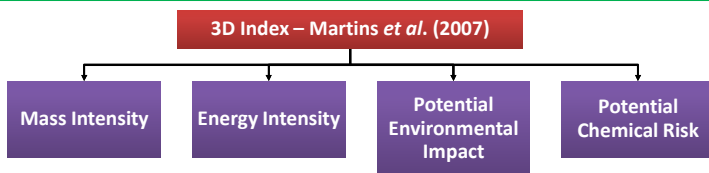

RESULTS AND DISCUSSIONS

1) EXISTING SEQUENCE SUSTAINABILITY ANALYSIS

A total of 189.20 MW energy is used to achieve 99.9 % of product recovery in the existing sequence. From the results, the calculated sustainability index is 856.64 obtained from the sustainability evaluator.

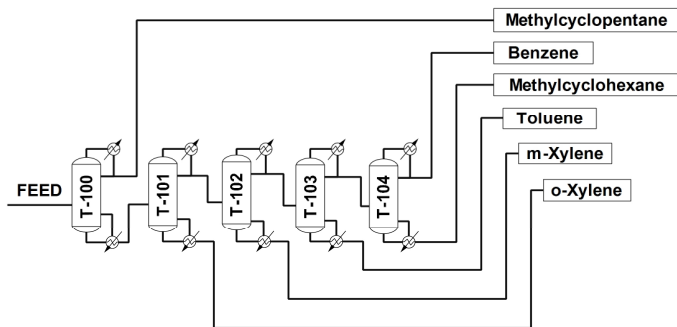

ACKNOWLEDGEMENT

The financial support from Universiti Teknologi Malaysia (RUGS Tier 1 Q.J130000.2509.07H39) and Ministry of Education of Malaysia FRGS (R.J130000.7809.4F435) are highly acknowledged.

2) OPTIMAL SEQUENCE SEPARATION DETERMINATION

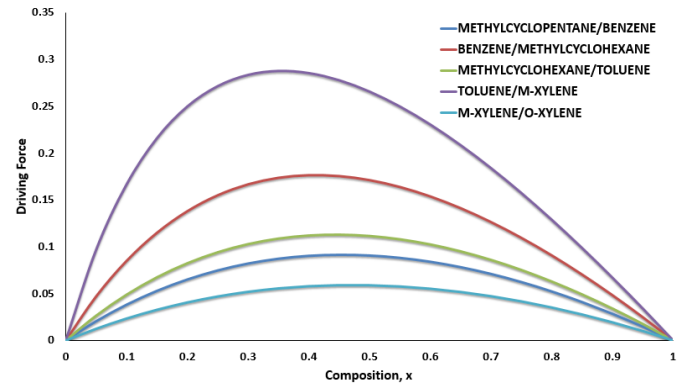

3) OPTIMAL SEQUENCE SUSTAINABILITY ANALYSIS

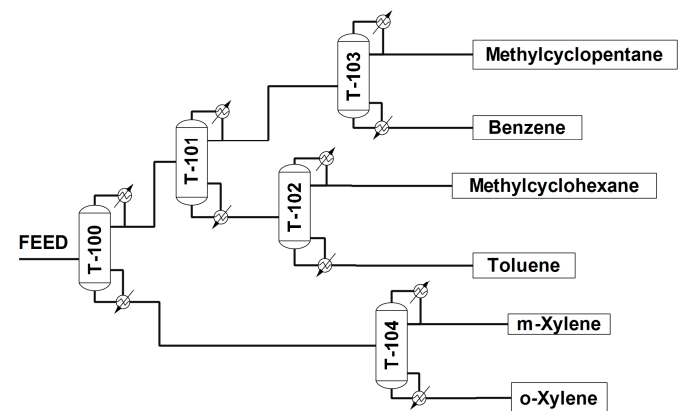

4) SUSTAINABILITY COMPARISON AND DESIGN MODIFICATION

	Direct-Indirect Sequence	Driving Force Sequence	Percentage (%)
Energy Consumption (MW)	189.20	179.91	4.91
Sustainability Index (SU)	856.64	847.35	1.08

Repiping Cost (\$)	69,328
Total Modification Cost (\$)	1,146,363
Total Energy Saving (\$/yr)	2,198,230
Return of Investment (ROI)	1.92
Payback Period	6 months

REFERENCES

- Mustafa, M. F., Samad, N. A. F. A., Ibrahim, K. A. & Hamid, M. K. A. 2014. Methodology Development for Designing Energy Efficient Distillation Column Systems. *Energy Procedia*, 61, 2550-2553.
- Bek-Pedersen, E. & Gani, R. 2004. Design and synthesis of distillation systems using a driving-force-based approach. *Chemical Engineering and Processing: Process Intensification*, 43, 251-262.
- Shadiya, O. O. & High, K. A. 2013. Sustainability evaluator: Tool for evaluating process sustainability. *Environmental Progress & Sustainable Energy*, 32, 749-761.
- Dimian, A. C., Bildea, C. S. & Kiss, A. A. 2014. Chapter 17 - Sustainability Analysis. In: *Computer Aided Chemical Engineering*. Elsevier.

CONTACT DETAILS

Main author : mzakwan26@live.utm.my
 Corresponding author : kamaruddin@cheme.utm.my