

12th Global Conference on Sustainable Manufacturing

## Standard Verification Test for Industrialised Building System (IBS) Repetitive Manufacturing

Abdul Kadir Marsono, Wong Jing Ying\*, Masine Md. Tap, Yip Chun Chieh, Amir Haddadi

*Faculty of Civil Engineering, Universiti Teknologi Malaysia, Skudai 81310, Malaysia*

\* Corresponding author. Tel.: +6-016-916-9144; fax: +6-07-556-6157. E-mail address: [jywong@live.com.my](mailto:jywong@live.com.my)

### Abstract

New innovative Industrialised Building System (IBS) has been implemented in Malaysia. It is a sustainable approach, innovative technique and implements repetitive manufacturing using green materials. This paper presents one of the standard tests to check the design and strength of IBS components via an experimental flexural test and then verify the finite element analysis. One IBS frame was set-up, tested with two points of monotonic vertical loading, and analysed by Abaqus 6.12 software. The structural performance in nonlinear state was evaluated in load-displacement relationship of beam, crack pattern, mode of failure, and stresses at concrete and connection deformation to guide the further components inspection.

© 2015 The Authors. Published by Elsevier B.V. This is an open access article under the CC BY-NC-ND license (<http://creativecommons.org/licenses/by-nc-nd/4.0/>).

Peer-review under responsibility of Assembly Technology and Factory Management/Technische Universität Berlin.

*Keywords:* Sustainability, Industrialised Building System (IBS); repetitive manufacturing; experimental test; finite element analysis.

### 1. Introduction

Sustainable construction becomes a global concern as the sustainability awareness rises due to multiple variations from conventional wet civil construction. The traditional construction method [1, 2] is high in cost, unable to respond to huge demand within a short space of time and partially failed to produce acceptable quality construction products.

Kibert [3] has stated that sustainability in construction developments must result in the creation and responsible maintenance of a healthy built environment, based on ecological principles, and by means of an efficient use of resources.

IBS can be perceived as an alternative option in maintaining sustainability in construction. It has a better control of human resources, materials and cost, shorten construction period and increase the quality of buildings as well as enhance occupational health and safety [4, 5].

IBS is a sustainable approach and innovative technique that implements repetitive manufacturing in mass quantities of structural components offsite whereby it can control time, cost, quality, utilization of work force and promotes sustainable deliverables.

IBS promotes sustainability from its controlled production environment, minimization of waste generation, extensive usage of energy efficient building material, effective logistics and long term economic stability which can contribute to better investment in environmental technologies [6].

Construction Industry Development Board, CIDB [7] has defined IBS as a construction technique whereby the components are manufactured in a controlled environment either on or off site, transported, positioned and set up into a structure with minimal additional site works.

IBS could be the method of mechanization of construction that solves for a quick, affordable and environmental sustainable housing predicament in Malaysia.

#### 1.1. IBS repetitive manufacturing

Building and construction activities worldwide consume 3 billion tons of raw materials each year or 40 % of total world resources [8]. Therefore, an alternative has to be promoted to reduce the use of raw material in order to foster the civil construction sustainability.

The components of IBS are manufactured either in a factory, on or off sites, positioned, and assembled into place with a very minimal additional site work [9].

Using green building construction materials with repetitive finished steel products for the formwork system can conserve natural resources and at the same time the use of non-renewable resources can be reduced. In addition, integrating green building materials into formwork system can help reducing the environmental impacts associated with the extraction, transport, processing, fabrication, installation, reuse, recycling, and disposal of these formwork source materials [10].

Patented IBS components are cast inside steel moulding as shown in Figure 1. The steel mould is specially designed by IBS researchers to produce five components in a single casting. In addition, it can be reused for many times. The higher repetitive manufacturing would lower the cost of productions.



Fig. 1. Example of steel mould

### 1.2. Connection of IBS system

Connections between IBS components are the most critical part of the system as it controls the whole performance of IBS manufacturing, assembly and also during the use of the buildings.

According to Asiah et al. [11], the joints at any location of the system are required to be durable, fire-proof and water-proof for architectural performance. While the strength, rigidity, and ductility for mechanical efficiency and the ease of handling, installation and clearance for expansion as well as contraction are also needed. The purpose of connection is primarily to maintain the integrity of the structure even during the extreme applied loading event.

Elliott and Kim [12] have defined connection as the action place of forces (tension, shear, and compression) and/or moment (bending and torsion) pass through to the assembly that comprising one or more interfaces. The design of connection is therefore will functioning as both the structural elements and adjoining between elements and to facilitate the operation of IBS assembly.

Moghadasi and Marsono [13] had investigated structural behaviour of an innovative semi-rigid IBS beam-to-column connection. This connection was patented as Smart IBS and has the specifications of a precast hybrid steel-concrete connection. It consists of prefabricated reinforced concrete beam and column components with steel connectors at their ends. The whole system of Smart IBS is capable to be assembled to become twelve shapes of different buildings starting from residential, school, shop and et cetera to commercial buildings.

Wei Li et al. [14] use nonlinear finite element software, ABAQUS to simulate and investigate the mechanical behaviours of a composite reinforced concrete frame consisting of a continuous compound spiral hoop reinforced concrete column connected to steel beam of the buildings.

Yang et al. [15] define a hybrid precast concrete beam system as a coupling of an H-steel beam and a reinforced concrete beam. It was a simple ductile connection and assumed to be practical for precast concrete structures. They had investigated the flexural behaviour of hybrid precast with end beams connector of a standard H-steel beams.

Kukreti et al. [16] had developed moment-rotation relationship for a bolted steel end-plate connection based on finite element modelling. Experimental testing is conducted on selected specimens and verified with the finite element modelling at certain accuracy.

Sherbourne and Bahaari [17] had developed a 3D model to investigate the behaviour of steel bolted end-plate connections. Maggi et al. [18] had used 3D models to analyse the behaviour of bolted extended end-plate connections parametrically as well. The presented results were focus on the variations of behaviour of the bolted extended end plate connections along the changes in plate thickness and bolt diameter.

Gustavo et al. [19] had conducted an experimental study on various connection schemes between the precast hybrid beams and reinforced concrete columns for precast earthquake-resistant building construction. Various connection schemes between the precast hybrid beams and RC columns were experimentally evaluated to achieve an adequate moment and shear transfer during large displacement reversals that occurring during earthquake movement.

Concepción et al. [20] had studied the rotational behaviour of steel end-plate connections of C-shaped using the finite element method. A full three-dimensional ANSYS finite element model of steel beam to column bolted extended end plate joints was analysed to obtain their behaviour. The model includes contact and sliding between different elements, bolt pre-tension, geometric and material non-linearity.

## 2. Case study of SMART IBS, an Industrialised Building System

SMART IBS is an internationally patented building system assembly [21]. The behaviour of new innovative IBS frame is presented in this paper. IBS components are designed and checked to comply with BS 8110 [22] and Eurocode 2 [23]. The beam-column was assembled using hybrid connection of plate, bolt and nut. This study reveals the real ultimate capacity and nonlinear behaviour of IBS frame through experimental and FEA that casted inside the repetitive industrial steel moulding.

### 2.1. IBS structural specification

One full scale IBS sub-frame was constructed and tested to investigate the ultimate capacity of beam at non-linear state. The sub-frame consists of one beam and two half height columns. The clear length of beam is 3300 mm and height of the column is 1150 mm (half height). Both beam and column have 300 mm x 300 mm cross section. Column concrete has

slot hole of 50x50x400 mm to provide connection for wall infill. Steel plates are used to connect wall infill to the column. Steel rectangular hollow sections (RHS) of 120x120x600 mm from column are connected to the U-shaped 200x800x10 mm steel plates at beam-ends by using two bolts and nuts at both sides. The diameter of steel reinforcements and links are 16 mm and 6 mm respectively. The cover of 30 mm is provided to fulfil the requirement of fire, durability and corrosion protection as in BS 8110. Figure 2 shows the detail specifications and detailing of the model.

The U-shaped steel plates are the full welded parts on two 16 mm diameter longitudinal main reinforcements at top and bottom in IBS beam. Then, steel RHS of column was casted together into concrete to provide fully bond between concrete and steel connector. The casting produces IBS components of beams and columns elements. The components were later connected through joints to form a skeletal building system.

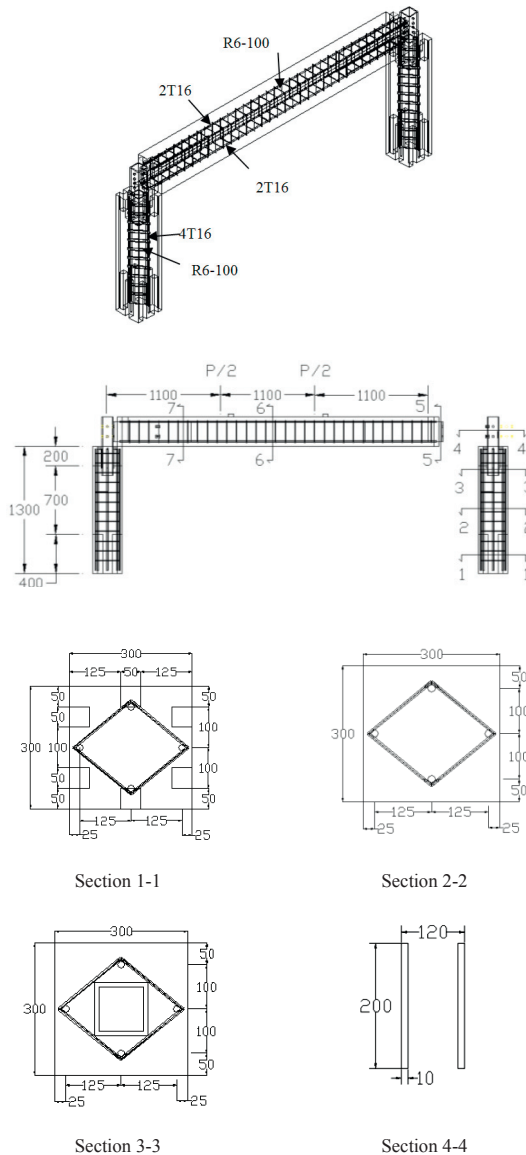

Fig. 2. Structural specification of SMART IBS

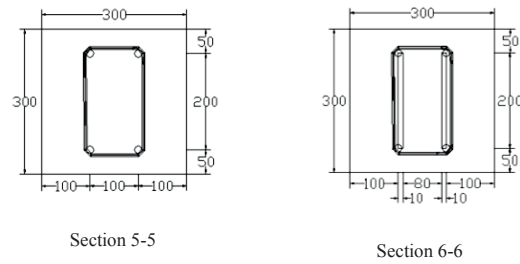

Fig. 2 (cont'd). Structural specification of SMART IBS

**3. Methodology of study**

In experimental test, an IBS frame was assembled and tested by two-point vertical loads at the centerline of  $\frac{1}{3}$  and  $\frac{2}{3}$  of beam's length inside the structural testing rig as illustrated in Figure 3. Three LVDTs (Linear Variable Differential Transformers) were installed at bottom of beam to measure the vertical deflection. Load cells and LVDTs were connected to a data logger to record and save the small steps of monotonic load. Figure 4 shows finite element modelling in ABAQUS 6.12 for non-linear analysis. Similar specifications, material properties, boundary conditions and loads were assigned into ABAQUS to simulate the real experimental model.

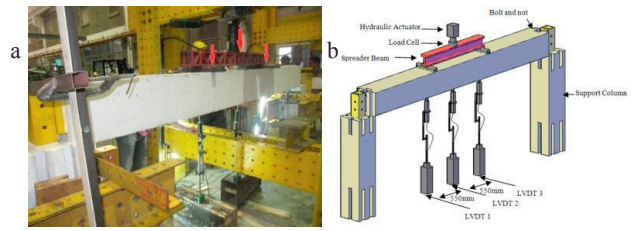

Fig. 3. (a) Experimental test set-up; (b) Perspective view of test setup

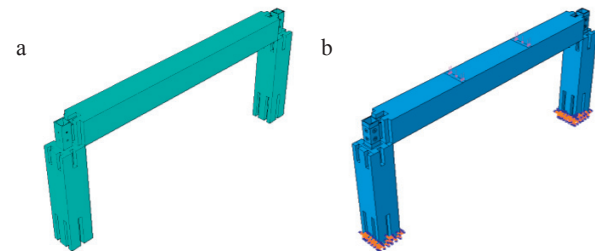

Fig. 4. (a) Frame modelling in Abaqus (b) Load and boundary condition modelling in Abaqus.

**4. Result and discussion**

*4.1. Load-displacement relationship of beam*

Full scale IBS frame system was tested using standard method for strength test and the result was plotted in load-displacement diagram until last step of loading (ultimate

loading step). The serviceable capacity of beam was known based on the Eurocode allowable deflection of 14 mm (centre to centre support span/250). Maximum load capacity is determined when the beam was losing its internal resistance with indication of increase in deflection at the same time decrease in applied load. This is the state of collapse of the system.

Figure 5 shows the experimental load-displacement at four points (mid-span, under steel connection and under two point loads). The beam behaves elastically up to 50 kN before proceed to non-linear behaviour with appearance of first vertical crack at mid-span. Then, the stiffness of beam was reducing as plastic behaviour starts to control the structural system.

Figure 5 shows that the ultimate load capacity was 133 kN with deflection of 24.13 mm. There were a lot of newly form and propagated cracks in the mid-span of beam which means the bottom beam was essentially in flexural tension and ductile state. Once the concrete has cracked and deformed, the force that sustained previously by concrete had distributed to the tensile reinforcement through the uncracked region of concrete. Mid-span deflection was measured by a linear variable displacement transformer (LVDT) beneath the soffit of the beam centre line.

The maximum vertical displacement of 11.26 mm that was measured at the exterior side of composite connection when reached ultimate capacity of 133 kN was shown by line A in Figure 5. The movement was due to the rotation of the bottom part of beam against the column connection.

The deflection under two points load was shown by line B and D. The first flexural crack was occurred at load 50 kN and thus stiffness began to reduce with declining of curve slope. The reinforcement bars have to sustain the load in tension and therefore, the whole beam was in ductile condition. The deflections of beam under two point loads were 16.95 mm and 16.55 mm respectively.

The load-deflection relationship for experimental test and FEA was shown in Figure 6. IBS beam in FEA was bending when loads were applied and the deformation pattern was similar to the experimental test. In FEA, IBS beam was reached deflection of 22.61 mm at 167 kN load.

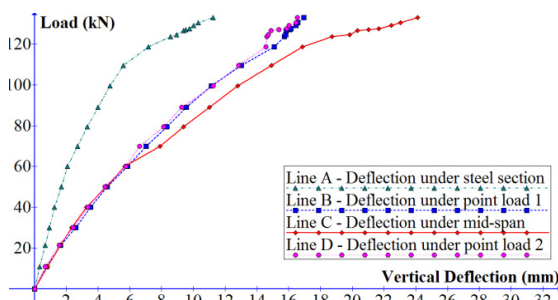

Fig. 5. Experimental load-displacement relationship

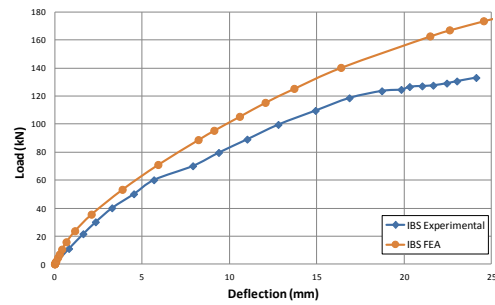

Fig. 6. Comparison of load-displacement relationship at mid span of beam in experimental test and FEA

#### 4.2. Crack pattern and mode of failure between experimental and finite elements

In experiment, the beam was loaded and went to linear-elastic state first. Then, first flexural crack was occurred at the maximum moment zone at the bottom side of beam. As the load increases, more vertical flexural cracks were formed and propagated upwards at mid-span region of the beam. Mode of failure and the progressive growth of cracks of beam under two point loads were shown in Figure 7.

Nonlinear phase was started with the development of numerous flexural cracks. This was due to flexural state of the beam with compressive stress concentrated at top and tensile stress occurred at the bottom of beam. In this state, the beam has lost its elasticity and permanently deformed. Diagonal tension cracks were observed on the beam at location near the support (column). As the load increases further, the stiffness of the beam reduces drastically with the yielding of the internal steel reinforcements. This means reinforcing bars already reached its yield strength and met the maximum beam capacity. At this stage, steel bar starts to undergo plastic deformation and concrete beam is in plastic state.

Figure 8 shows AC yield of IBS frame at 125 kN in FEA. The occurrence of flexural crack at the maximum moment zone and diagonal tension cracks near the support were similarly observed in the experimental model. Severe damage at the connection could cause sudden failure of structure in shear mode.

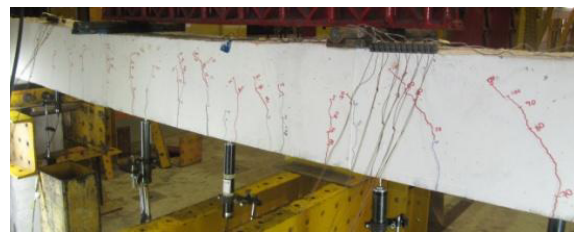

Fig. 7. Experimental crack distribution at load 133 kN





Fig. 8. AC yield of IBS frame at 125 kN

4.3. FEA stress of concrete material

Maximum principal stress for concrete element in finite element was used to locate the area of concrete cracks whereas minimum principal stress can determine the location of concrete crushing. The contour plot with different colours shows different principal stresses occurred in concrete. The maximum and minimum principle stresses of concrete were shown in Figure 9 and 10 respectively. Figure 9 shows the column concrete around RHS was cracked due to the applied force acting vertically and hence RHS was bending inward and creates stresses at the surrounding of concrete. Colour contour of green to blue shows the location of concrete crushes in Figure 10.

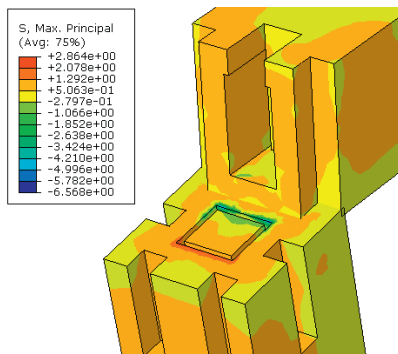

Fig. 9. FEA maximum principle stress of concrete at connection to define cracks of concrete

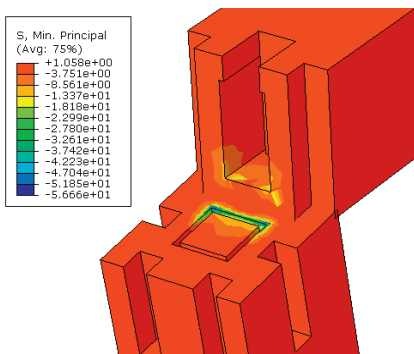

Fig. 10. FEA minimum principle stress of concrete at connection to define crush of concrete

4.4. Steel connection deformation

Connection deformations in FEA were verified by experimental test. The load that sustained previously by concrete beam had transferred to the main reinforcement once the concrete cracked. Consequently, the main reinforcements were in tension and the tensile stresses were transferred to the end plates. High tensile stress in end plates causes the plate starts to yield. Column rectangular connector (CRC) and bolts were also start to yield and hence the CRC bend inward towards the steel plate of beam. Further additional loadings may cause the failure of connection.

The yielding of steel end plate from experimental and FEA were shown in Figure 11 and 12 respectively. It was clearly shown that deformed pattern in beam steel plate and CRC of column from simulations were similar to experimental test. Figure 13 shows maximum principle stresses of RHS, steel plate, and bolt and nut at 140 kN. The colour contour of stresses show the steel has suffered from buckling and yielding. The connections will fail with further applied loads when steel plate of beam, CRC of column and bolts reached beyond their ultimate capacity. Hence, high tensile strength of steel plate, CRC, and bolted connection in IBS frame allows more deformation and bending taken by connection without causing much cracking and crushing in the concrete.

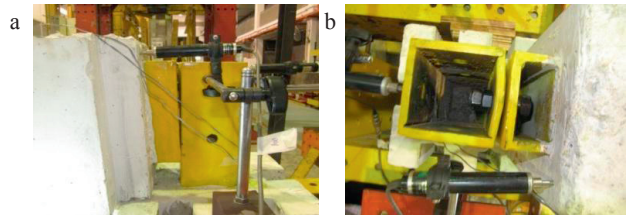

Fig. 11. Experimental (a) front view of deformation; (b) top view of deformation

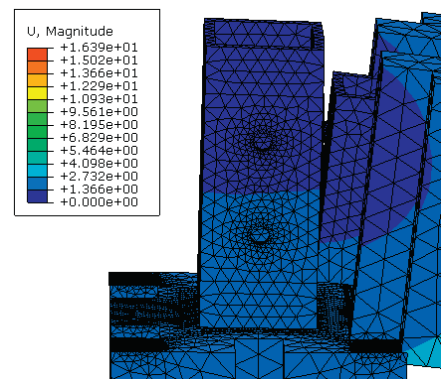

Fig. 12. FEA deformation of IBS connection at 140 kN

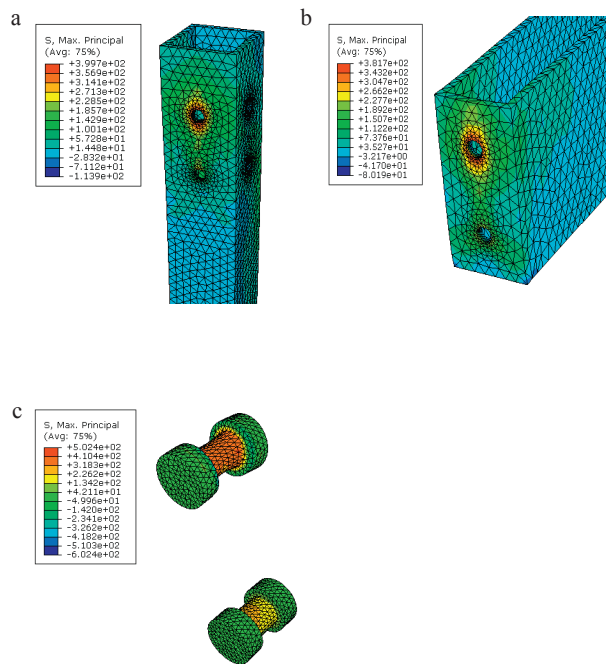

Fig.13. FEA maximum principle stresses of IBS components at 140 kN (a) RHS section (b) steel plate and (c) bolt and nut

## 5. Conclusion

Industrialised Building System (IBS) is a sustainable approach and innovative technique that implements repetitive manufacturing using green materials for moulding of reinforced concrete components. The components manufacturing in factory can be made under strict quality control. Several tests of full scale IBS experimental and FEA have to be carried out to achieve a reliable IBS components production to the structural engineering quality and meet the Eurocode of practice requirements. The experimental ultimate capacity of new innovative IBS beam was 133 kN with 24.13 mm deflection at mid-span of beam. The deformation patterns of frame in experiment and FEA were similar. The yielding of U-shaped beam steel plate, steel CRC and bolts and nuts were proven similar in both experimental test and FEA. With this confidence result of both methods, other development may singly rely on FEA due to high costs of physical tests on batches of production. Hence, the standard test of IBS products that made with seasons steel repetitive mouldings were presented in this paper.

## Acknowledgements

This research is supported by UTM-URG-QJ130000.2522.05H06, Elastic Infills, Beams and Column for Natural Disaster Home

## References

- [1] Agus, M. R., 1997. Urban development and housing policy in Malaysia. *International Journal Housing Science Application* 21(2), 97–106.
- [2] Senturer, A., 2001. Which Industrialized Systems Are Appropriate for Turkey. Available at: [www.emu.edu.tr/academic/publicat/archpub/arch-32a.htm](http://www.emu.edu.tr/academic/publicat/archpub/arch-32a.htm)
- [3] Kibert, C. J., 2007. The next generation of sustainable construction. *Building Research & Information* 35 (6):595 - 601.
- [4] Blismas, N. G., M. Pendlebury, A. Gibb, C. Pasquire, 2005. Constraints to the use of off-site production on construction projects. *Architectural Engineering and Design Management* (1); 153-62.
- [5] Luo, Y., R. Riley, M. J. Horman, G. O. Kremer, 2008. Decision Support Methodology for Prefabrication Decisions on Green Building Projects. Symposium on Sustainability and Value Through Construction Procurement 29 November – 2 December 2006. University of Salford.
- [6] Kamarul Anuar Mohamad Kamar, Zuhairi Abd. Hamid, Mohd Khairolden Ghani, Charles Egbu, Mohammed Arif, 2010. Collaboration initiative on green construction and sustainability through industrialized buildings systems (IBS) in the Malaysian Construction Industry. *International Journal of Sustainable Construction Engineering & Technology* 1 (1). pp. 119-127. ISSN 2180-3242
- [7] Construction Industry Development Board (CIDB) Malaysia (2003a) IBS Roadmap 2003-2010, Construction Industry Development Board Malaysia (CIDB), Kuala Lumpur.
- [8] Roodman, D. and N. Lenssen, 1995. A Building Evolution: How Ecology and Health Concerns Are Transforming Construction World Watch Paper.
- [9] IBS Roadmap 2003-2010, 2003. Construction Industry Development Board (CIDB), Kuala Lumpur
- [10] Rosli Mohamad Zin, Mohd Affendi Ismail, Mohammed Taher Alashwal, Suriani Hassin, Rozana Zakaria, 2012. Sustainability Elements of IBS Formworks System in Malaysia. *Applied Mechanics and Materials* Vols. 174-177. pp 2102-2106
- [11] Asiah Abdul Rahim, Zuhairi Abdul Hamid, Ismawi Hj. Zen, Zulkefle Ismail, Kamarul Anuar Mohd Kamar, 2012. Adaptable Housing of Precast Panel System in Malaysia. *Procedia - Social and Behavioral Sciences* 50, 369 – 382
- [12] Elliott, Kim S., 2003. Off site prefabrication of concrete structures. International conference on IBS. Kuala Lumpur, Malaysia. September 10-11. Kuala Lumpur: CIDB. pp. 6-18.
- [13] Moghadasi M., Marsono A.K., 2012. Comparative experimental study of full-scale H-subframe using a new industrialized building system and monolithic reinforced concrete beam-to-column connection. *The Structural Design of Tall and Special Buildings*. Published online in Wiley Online Library.
- [14] Wei Li, Qing-Ning Li and Wei-Shan Jiang, 2012. Nonlinear finite element analysis of behaviors of steel beam– continuous compound spiral stirrups reinforced concrete column frame structures. *Struct. Design Tall Spec. Build.*
- [15] Yang K.H., Oh M.H., Kim M.H., Lee H.C., 2010. Flexural behavior of hybrid precast concrete beams with H-steel beams at both ends. *Engineering Structures* 32 2940-2949
- [16] Kukreti A.R., Murray T.M., Abolmaali A., 1987. End-plate connection moment-rotation relationship. *Journal of Construction steel research* Vol.8 137-157
- [17] Sherbourne A.N., Bahaari M.R., 1996. 3D simulation of end-plate bolted connections. *J Struct Eng* 120(11):3122–36.
- [18] Maggi YI, Gonçalves RM, Leon RT, Ribeiro LF, 2005. Parametric analysis of steel bolted end plate connections using finite element modelling. *J Constructional Steel Res* 61:689–708.
- [19] Gustavo J. P-M, Prabhuddha D., Subhash C. G., 2005. Development of connections between hybrid steel truss–FRC beams and RC columns for precast earthquake-resistant framed construction. *Engineering Structures* 27 1931–1941
- [20] Concepción Díaz, Mariano Victoria, Pascual Martí, Osvaldo M. Querin, 2011. FE model of beam-to-column extended end-plate joints. *Journal of Constructional Steel Research* 67 1578–1590
- [21] Building Assembly System. International Patent No: W00201103123 PCT/MY/2011/000182. Dr. A.K. Marsono, Dr. Ahmad Mahir Makhtar, Dr. Masine Md. Tap.
- [22] BS 8110-1:1997 Structural Use of Concrete. Part 1: Code of Practice for Design and Construction.
- [23] European Committee for Standardization, Eurocode EC2, 2004. Design of Concrete Structures (BS EN 1992), General Rules for Buildings. CEN: Brussels.