

Research Article

Effect of Engagement and Collaborative Learning on Satisfaction Through the use of Social Media on Malaysian Higher Education

Waleed Mugahed Al-Rahmi, Mohd Shahizan Othman and Lizawati Mi Yusuf

Department of Information System, Faculty of Computing, Universiti Teknologi Malaysia,
Johor Bahru, 81310, Malaysia

Abstract: As social networks continue to proliferate, the question arises as to how to attract students and researchers to different online sites. In this regard, the present study focused on the interactivity of social networks and their role in satisfying students. Accordingly, this study proposed a model comprising of factors that assist in answering the study questions. A developed questionnaire was then distributed to 132 students and users' of social media websites that obtains relevant information regarding technology acceptance, interactivity and satisfaction of students. The findings suggested that both Technology Acceptance Model (TAM) related factors as well as interactivity affect the satisfaction and academic performance of students.

Keywords: Collaborative learning, engagement, higher education, satisfaction, social media

INTRODUCTION

This study investigates social media network in terms of collaborative group learning and how students and academics perceive social media in the context of Malaysian Higher Education. To this end, knowledge of the way university students employ social media will assist higher learning institutions to bring about effective decision making regarding technology adoption in this field (Corrin *et al.*, 2010). A social media refers to a portable web tool that can be accessed via platform that is independent of web-browsers and that stresses on social activities for collaborative, communicative, community and creative work (Joosten, 2012).

The perception in this regard is such that social media is able to assist in enhancing students' learning by attracting their interest towards taking part in informal learning activities and processes. The use of such technologies can motivate and attract tacit knowledge of students towards informal learning scenarios (Joosten, 2012).

Dabbas and Kitsantas (2012) reported that social media can help facilitate the creation of personal learning environments, which empower students to take charge of their own learning by selecting, creating and organizing tools and resources that help in effective and efficient learning (Rubin, 2010). Informal learning has been described in as among the crucial learning trends while social software can be utilized to motivate critical thinking, team work, creativity and self-paced learning among students (Cluett and Skene, 2007) and in turn,

these skills can assist students in developing relevant learning methods. Many instructors of higher education institutions have started to explore technology that can enhance their teaching as well as enhance collaborative learning among students (Selwyn, 2010). Tess (2013) suggested instructors not only to concentrate on the practical integration of technology into the courses, but also to focus on the theoretical framework for implementing the technology as a learning resource. Yet, the focus on theoretical framework has not been given much emphasis by the instructors in higher education institution (Merchant, 2012). As such, this study highlights the use of Social Media for collaborative learning to improve academic performance in Malaysian higher education by examining the effect of engagement and satisfaction on using social media networks. Malaysian institutions rarely focus on students' usage of social media technologies or a conceptual framework to help explain the outcomes. Some studies in this area have reported the use of Social Networking Sites among students in Malaysian universities for informal learning (Hamat *et al.*, 2012a), use of social media network focused on personality traits of students (Abdul Hamid *et al.*, 2013) and examining how top performing students' use Social Networking Sites (Hamat *et al.*, 2012b). In related studies (Al-rahmi *et al.*, 2014; Mora-Soto *et al.*, 2009), it can be deduced that technology on its own has the capability of facilitating knowledge transfer and relating two significant elements namely learning and knowledge. To this end, authors brought forward collaborative learning and engagement through a notion

Corresponding Author: Waleed Mugahed Al-Rahmi, Department of Information System, Faculty of Computing, Universiti Teknologi Malaysia, Johor Bahru, 81310, Malaysia

This work is licensed under a Creative Commons Attribution 4.0 International License (URL: <http://creativecommons.org/licenses/by/4.0/>).

underpinned by the constructivist theory. Other authors (TAM), where the theory makes use of social media network coupled with collaborative learning environment to improve students' and researchers' satisfaction in group learning and to enhance their academic performance.

USING SOCIAL MEDIA IN HIGHER EDUCATION

This section addresses the use of social media network in support of collaborative learning and its effect on engagement and satisfaction of researchers and students' academic performance. Social media covers blogs, wikis, media in the form of audio, photo, video and text, sharing tools, platforms for networking like the current Facebook craze and other social networks. The present study proposes that employing social media as an educational tool can result in engagement and collaborative learning of students (Chen *et al.*, 2010; Junco, 2012a). Students can create networks with peers, set up virtual society of learners and eventually maximize their learning capabilities through social media (Fewkes and McCabe, 2012; Yu *et al.*, 2010). Moreover, students develop learning communities via collaborative learning to obtain knowledge. To this end, social media works as a facilitator in the creation of such learning communities as it motivates collaboration and communication among students. Such interactions in turn support the realization of positive outcomes of learning (Yu *et al.*, 2010).

Furthermore, social media enables students to extend their learning environment from their classrooms as only a portion of learning actually happens in it (Chen and Bryer, 2012). Educators are responsible to determine methods to include social media network in the classrooms (Fewkes and McCabe, 2012) in order to develop students' creativity and allow them to explore the curriculum in new and interesting

recommended the Technology Acceptance Model methods (Frye *et al.*, 2010). Consequently, social media reinforces collaborative learning which supports engagement and creative processes of learning (Shoshani and Rose Braun, 2007). In fact, collaborative learning comprises students' interaction and network connections with their peers and with the curriculum. To this end, according to Chen *et al.* (2010), student staking online courses spend most of their time making use of online tools and social media to supplement their learning tools compared to their counterparts who learn through face-to-face instruction. Hence, it is logical to conclude that active engagement, collective learning and mapping out of virtual relationships via social media open up opportunities for maximized learning as students are motivated to develop a network of connections with sources extending outside of their classrooms (Fewkes and McCabe, 2012; Yu *et al.*, 2010).

CONCEPTUAL FRAMEWORK AND HYPOTHESES

This study attempts to explain the framework (Fig. 1) proposed for the impact of social media use on collaborative learning and engagement among students and researchers at the National University of Malaysia (UKM), with the help of the constructivism theory and Technology Acceptance Model (TAM). The present study revealed that social media integration is linked to the collaborative learning among students. The social media variables include interactive with research Group Members (GM), interactive with Supervisors (SU), Engagement (EN), Perceived Ease of use (PE), Perceived Usefulness (PU), Intention to Use (IU), Collaborative Learning (CL) and Researchers Satisfaction (RS).

Interaction with group members and supervisors:
The huge success and proliferation of social networks

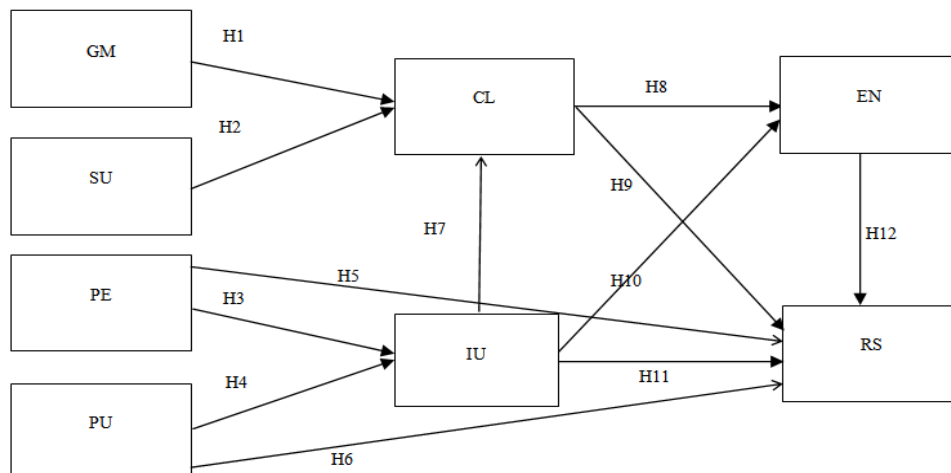

Fig. 1: Conceptual framework

in the student population has convinced educators that they can be employed as a learning tool although caution has to be taken in their employment. Among the top crucial contributions of social media networks to the education field is that it opens opportunities for knowledge sharing and this knowledge may be used to resolve issues throughout the network (Mason and Rennie, 2008).

In the field of education, the processes and methods of teaching and learning is ever-evolving to suit the needs of society. As mentioned, one of the most recent technologies included in today's educational field is social media particularly among students and researchers (McLuhan, 1962). In fact, teachers often complain of students surfing and checking their statuses in Facebook while in the class. However, through these computer systems, students' interaction among each other was acknowledged to be a societal phenomenon (McLuhan, 1962). In this context, knowledge is introduced to social media network via the content shared and created by the users and in the context of educational social media network, teachers as well as students can create new content and address questions to contribute to collective learning experience (Withers, 2007).

Aside from the usefulness of the social network, the environment wherein it can be realized appears interesting, fun and entertaining to students while they rehash related educational topics. Several studies (Withers, 2007; Lenhart and Madden, 2007) have urged caution in using social networks in educational field erroneously while others highlighted the benefits of their usage in education by researchers and students alike in terms of site building, blogging and media sharing and interactive collaborative learning. In addition to this, social media features and network nurtures creativity and assist researchers and students to manage their peer group and improve their research skills. Therefore, we propose the following hypotheses.

H1: There's a significant relationship between interactivity with group members and collaborative learning.

H2: There's a significant relationship between interactivity with supervisors and collaborative learning.

Collaborative learning theory: Both researchers and students have a chance to experiment on a computer supported collaborative learning and use social media network platform. This is easily realized as almost everyone in this day and age is using social media although for different reasons. In the educational field, lecturers play the role of instructors or mentors whereas students are categorized into groups. Studies dedicated to this experiment (Smith and San, 2007) of social media networking in classrooms demonstrated

successful realization of dynamic learning environment, whereby students are engaged in knowledge and experience of the shared environment where e-learning platform is utilized. The learning environment refers to the learning place or an activity space that can sense learning scenarios, identify the characteristics of learners, provide appropriate learning resources and convenient interactive tools for collaborative learning and automatically record the learning process and evaluate learning outcomes in order to promote effective learning (Huang *et al.*, 2013). Formal collaborative learning consists of students studying together to achieve shared learning objectives and complete jointly specific tasks and assignments, while informal collaborative learning consists of having students work together to achieve a joint learning goal in temporary groups that last from a few minutes to one class period (Johnson and Johnson, 2008). Thus, we propose the following hypotheses.

H8: There's a significant relationship between collaborative learning and engagement.

H9: There's a significant relationship between collaborative learning and students and researchers satisfying.

Engagement: International students appear to be confident in using social media network in sharing their experiences and acclimating to the new culture and language, with evidence in literature pointing to the fact that social media created by students are derived from the creation of community of practice where international students offer support and relevant information in a student community. In this context, in higher education it was revealed by Montgomery and McDowell (2009) that relationships that are developed beyond the classroom enhance the international students' learning experience by informally setting up social media network. Hence, the students' perceptions of being part of a group shape social networks and enrich the students' learning experience as they take advantage of the relationships among their peers. To this end, engagement refers to student-faculty interaction, peer-to-peer collaboration and active learning (Chen *et al.*, 2008) and it has been demonstrated to positively relate to the learning experience quality. Learning engagement is the process in which students actively participate in their learning. However, CSCL analyses generally focus on only one of these units, even in multi-method approaches. The learning designs are always reflected in activities and students may have different learning resources when they have different activities. Sampson *et al.* (2011) proposed learning design repositories to orchestrate different activities and resources while Clegg *et al.* (2013) used social media network to support more collaborative interactions through highlighting the

importance of providing support for facilitating scientific communication and underscoring the importance of factoring the learning context into the design and implementation of using social media for collaborative learning and engagement. Therefore, we propose the following hypothesis.

H12: There's a significant relationship between engagement and researchers' satisfaction.

Technology acceptance model: The Technology Acceptance Model (TAM) is one of the most cited models in explaining attitudes toward technology such as using social media. According to TAM, Perceived Usefulness (PU) and Perceived ease of Use (PEU) are the two major factors that influence rejection or acceptance of a technology. It is in the sight of this research, models and theories that we have dedicated this study to the analysis and study of the intention to use and students' satisfaction towards the use of social networks for collaborative learning and engagement. More precisely, our research considers the following factors.

Perceive ease of use, perceived usefulness and intention to use social media: Both perceived ease of use and perceived usefulness were found to positively impact behavioral intention towards using the system (Doll and Torkzadeh, 1998) and perceived ease of use was reported to positively impact perceived usefulness (Lee *et al.*, 2011). The perceived ease of use-perceived usefulness relationship has been focused on by various authors (Srite, 2006). Among these studies, (Venkatesh and Davis, 2000) contended that simple, easy to use and user-friendly technology will be perceived to have more usefulness. On top of this, perceived usefulness and ease of use reinforce the investigation of students' acceptance of using Blackboard in higher learning institutions (Landry *et al.*, 2006) and it was one of the predictors of acceptance and usage of e-learning systems (Saeed *et al.*, 2009). Despite the fact that some authors claimed that attitude towards usage of systems mediate the impact of perceived ease of use and perceived usefulness on behavioral intention (Kim, 2008), according to Davis *et al.* (1989), perceived usefulness may directly affect behavioral intention to use technology regardless of attitude towards the system.

Considerable research has been done on the above variables that have been proposed in the theory of reasoned acceptance where users either accept or reject information technology use judging from its ease of use or perceived usefulness (Venkatesh and Bala, 2008). The TAM model has also been utilized to predict user acceptance and use on the basis of both perceived usefulness and ease of use (Davis, 1989). Because perception may result in behavior it is safe to conclude that TAMs usefulness will be impacted by ease of use owing to the fact that technology that is easy to use are

perceived as more useful (Devaraj *et al.*, 2008). This behavior however calls for valid relations for its maintenance-relations that can be urged through social media networks (Coyle and Vaughn, 2008).

In our day to day lives, social networks are confined to the cyber world taking up new faces and designs and hence it is significant to examine the level to which usefulness, ease of use and intention to use in terms of collaborative learning through such networks. In this context, the TAM model determines two basic determinants of user acceptance of innovations in technology which are perceived usefulness and perceived ease of use as the primary determinants of intention to use social media networks. Perceived usefulness refers to the user's subjective probability that making use of a particular application system will enhance his performance on the job (Davis, 1989). Prior studies showed that perceived usefulness determines acceptance and usage of technology (Lopping and McKinney, 2004). In the context of the Internet, the evaluation of information usefulness among information seekers is a common and widespread occurrence (Tombros *et al.*, 2005). According to Lim (2009), usefulness significantly impacts social media tool use among college students. Added to this, the ongoing usage intention of social networking services by users has been shown to be a predictor of perceived usefulness and perceived enjoyment of such users (Kim, 2011). In this study, the model comprises of factors of perceived ease of use and perceived usefulness-factors that directly impact behavioral intention to use and accept technology (i.e., social media). Hence, we propose the following hypotheses.

H3: There's a significant relationship between perceived ease of use and intention to use.

H4: There's a significant relationship between perceived usefulness and intention to use.

H5: There's a significant relationship between perceived ease of use and students and researchers satisfying.

H6: There's a significant relationship between perceived usefulness and students and researchers satisfying.

H7: There's a significant relationship between intention to use and collaborative learning.

H10: There's a significant relationship between intention to use and engagement.

H11: There's a significant relationship between intention to use and researchers' satisfaction.

Researchers satisfaction: Perceived usefulness is a significant variable to be considered in user's adoption and satisfaction of technologies. Perceived usefulness was reported to significantly predict users' satisfaction of website (Green and Pearson, 2011) as well as computers (Davis *et al.*, 1989). While some studies showed user entertainment significant role in

technology success, others showed that adoption and satisfaction levels of IS systems and products are related with user perceptions of entertainment furnished by the technology (Kim *et al.*, 2009). In this regard, (Bernard *et al.*, 2009) reached to the conclusion that the entire interaction types are crucial and should be included into online courses as they improve students' learning and satisfaction. The level of satisfaction may be affected by the combined nature of usefulness perceived and ease of use throughout the interactive elements of social networks in light of information and technical features (Wixom and Todd, 2005). In this sense, interactivity may lead to maximized satisfaction with social media network usage. It can therefore be argued that part of the attraction of social media networks that are linked to collaborative learning and engagement is the potential information that can be availed from, from the network (Paxton, 1999). However, some proposed that both intrinsic motivation and extrinsic motivation can co-exist along with collaboration to foster learning (Lepper *et al.*, 2005) because students may engage in behavior that they like and that would also help them achieve good grades. Individuals with high level of intrinsic motivation would spur themselves to seek more information on the subject as the process of searching for; evaluating and organizing information would render them satisfaction.

Social media and academic performance: The use of social media in the educational field enhances the GPA of students and brings about peer feedback regarding assignments and students' reflections on curriculum as the communication is rampant and open within the network (Arnold and Paulus, 2010; Ebner *et al.*, 2010). Additionally, social media use in academic tasks may lead to maximized learning of the individual student. Participating students in curriculum tasks using social media display an increased GPA compared to non-participating students (Junco *et al.*, 2011). More importantly, the use of social media for the purpose of collaborative learning and engagement motivates long-term retention of information and an in-depth understanding of curriculum explained in class (Chen and Bryer, 2012; Heafner and Friedman, 2008). The results of the study showed that researchers and students using social media are well-aware of the course content through interactions outside of class and this eventually supports their in-classroom learning and enhance their skills in research.

RESEARCH METHODOLOGY

A survey study was conducted with students and researchers at the National University of Malaysia (UKM) as well as users of social media for collaborative learning and engagement. Potential respondents were solicited from postgraduate students. The potential study sample was 132 respondents to which the surveys were administered manually. The

survey items were measured with the help of five point Likert scale and they include TAM related variables and those relating to interactive factors and demographic characteristics. The sample study was requested to answer questions regarding the use of social media network for the purpose of collaborative learning and engagement and its effect on the students' and researchers' satisfaction in the field of education. Data analysis was conducted via IBM SPSS Version 20 and AMOS Version 16.

Sample characteristics: The surveys were completed by 205 respondents constituting 64.4% response rate, while 35.6% had missing data and outliers. Added to this the sample characteristic of the 132 respondents are as followed; there were 58 male respondents and 74 female respondents equating to 43.9 and 56.1%, respectively. Sixteen respondents (12.1%) fell in the 21-24 age category, while fifty-nine (44.7%) of the respondents were in the 25-30 category. Thirty-eight (28.8%) respondents were in the 30-35 category and nineteen (14.4%) fell to the age category above 35. With regard to degree of respondents, thirty-seven (28.0%) respondents were in master full research program, five (3.8%) respondents were in master mixed mode program, twenty-two (16.7%) respondents were in master taught course and sixty-seven (50.8%) respondents were in PhD program and one (0.8%) respondent in Post-Doctoral program. Regarding the most used social media network, approximately 93.2% of the sample employed social media for both collaborative learning and engagement.

Data collection and measurement: The actual data collection was conducted with the help of a developed questionnaire distributed to 205 researchers, out of which 132 were completed and retrieved in the February 2014 semester. In addition to the variables of interest in our framework, the survey included questions about the researcher's overall impressions of social media (e.g., interactive with research group members, interactive with supervisor, engagement, collaborative learning, researcher's satisfaction and performance of the researchers) to benefits of using this technology (e.g., sharing knowledge, exchange information, interaction, collaborative learning). The results showed that researcher's awareness via perceived ease of use and perceived usefulness and intention to use social media, motivated intention to use and enhanced collaborative learning. In other words, social media maximizes the perceived interaction quality among researchers and among researchers and supervisors (Ajjan and Hartshorne, 2008). Interaction is considered as a critical aspect of the training process as it encourages researchers to be active in class for collaborative learning (So and Brush, 2008; Al-Rahmi and Othman, 2013). This proved positive for perceived ease of use, perceived usefulness and intention to use social media (Kim *et al.*, 2007) and hence, it is reasonable to state that the above variables (Yu *et al.*,

2010) and collaborative learning among researchers in universities lead improved researcher’s performance, enhanced Collaborative Learning (SSCL), improved understanding construction (Yampinij *et al.*, 2012) and improved academic success in higher education (Al-rahmi *et al.*, 2014).

RESULTS AND DISCUSSION

Background of respondents is obtained based on the result of questionnaire. the analysis result, the distribution of respondents on the basic demographic of the sample, the number of questioner respondents based on gender of researchers; the number of respondents based on their gender, which are Fifty-eight male respondents corresponding to (43.9%) and Seventy-four female respondents (56.1%). From the number of respondents, it can be known that the number of female respondents is highest than male respondents. This is not deliberate while the distribution of questionnaire.

The relationship between related factors that have to effect of engagement and collaborative learning on satisfaction through using social media on Malaysian higher education; and found the reliability Cronbach’s Alpha based on standardized items 0.958.

Measurement model analysis: Structural Equation Modeling (SEM) was employed as the main statically technique to analyses data with Confirmatory Factor Analysis (CFA) using Amos 16. We assessed the overall goodness-of-fit using fit Indices (X2, df, X2/df, RMR, IFI, TLI, CFI and RMSEA). The initial confirmatory factor analysis showed an acceptable overall model fit. The measurement model results are shown in Table 1.

Structural model analysis: In the next step of the Structural Equation Model (SEM), we run CFA to test structural framework. Table 2 show the structural this

Table 1: Fit indices for the measurement model

Model	X ²	df	X ² /df	RMR	IFI	TLI	CFI	RMSEA
	1356.779	947	1.43	0.037	0.913	0.994	0.914	0.047

Table 2: Regression weights

H	Independent	Relationship	Dependent	Estimate	S.E.	C.R.	p	Result
H1	GM	→	CL	0.213	0.028	7.607	***	Supported
H2	SU	→	CL	0.182	0.039	4.731	***	Supported
H3	PE	→	IU	0.339	0.035	9.660	***	Supported
H4	PU	→	IU	0.300	0.035	8.657	***	Supported
H5	PE	→	RS	0.095	0.036	2.642	**	Supported
H6	PU	→	RS	0.143	0.034	4.181	***	Supported
H7	IU	→	CL	0.438	0.038	11.505	***	Supported
H8	CL	→	EN	0.454	0.030	14.911	***	Supported
H9	CL	→	RS	0.154	0.033	4.647	***	Supported
H10	IU	→	EN	0.279	0.035	7.963	***	Supported
H11	IU	→	RS	0.250	0.034	7.413	***	Supported
H12	EN	→	RS	0.172	0.035	4.931	***	Supported
H13	GM	←	SU	0.182	0.016	11.389	***	Supported
H14	PE	←	PU	0.215	0.015	14.650	***	Supported

C.R.: Critical ratio or t-value standardized regression weights: (group number 1-default model); S.E.: Standard error

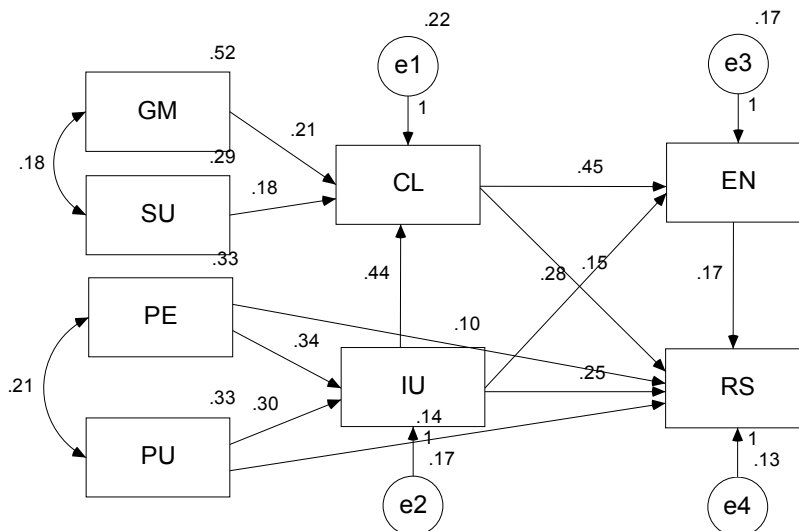

Fig. 2: Results for the proposed framework

framework also from table, it can be clearly seen that models' key statistics are very good. So, the framework is valid and we can continue to analysis the results of the hypothesizes.

Results of hypothesis testing: The results of this research provide support for the framework and for the hypotheses regarding the directional linkage between the framework's variables. The parameter un-standardized coefficients and standard errors for the structural framework are shown in Table 2.

Discussion and implications: The Table 2 above and Figure 2 indicate that collaborative learning positively and significantly with engagement ($\beta_2 = 0.454$, $p < 0.001$) Thus, hypothesis H8 was supported where there's a significant relationship between collaborative learning and engagement to impact the interactive with research group members and interactive with supervisor by using social media. Also indicate that intention to use social media positively and a high significantly with collaborative learning ($\beta_2 = 0.438$, $p < 0.001$) thus, hypothesis H7 was supported where there's a significant relationship between intention to use social media and collaborative learning to improve the research and easy interactivity among researchers by using social media.

The findings in Table 2 also confirmed that perceived ease of use found positively and significantly with intention to use social media was ($\beta_3 = 0.339$, $p < 0.001$); hence, hypothesis H3 was verified supported where there's a significant relationship among perceived ease of use and intention to use social media. Hence, the researchers use social media to information sharing or collaborative learning. The findings in Table 2 also the perceived usefulness positively and significantly with intention to use social media was ($\beta_3 = 0.300$, $p < 0.001$); hence, hypothesis H4 was supported where there's a significant relationship among perceived usefulness and intention to use social media. Thus, the researchers get effectiveness and intention to using social media for collaborative learning. The next, hypothesis ten confirmed that intention to use social media found positively and significantly with engagement was ($\beta_3 = 0.279$, $p < 0.001$); hence, hypothesis H10 was verified supported where there's a significant relationship between intention to use social media and engagement. Hence, the researchers get more resources and easy to information sharing that collaborative learning is improving students' academic performance.

Also indicate that intention to use social media positively and a high significantly with researchers satisfaction ($\beta_2 = 0.250$, $p < 0.001$) thus, hypothesis H11 was supported where there's a significant relationship between intention to use social media and researchers satisfaction to impact collaborative learning and

engagement by using social media. Next, hypothesis fourteen confirmed that perceived ease of use positively and significantly with perceived usefulness was ($\beta_3 = 0.215$, $p < 0.001$) thus, hypothesis H14 has a direct positive and significant effect where there's a significant relationship between perceived ease of use and perceived usefulness. Trough, intention to use social media allows the exchange of knowledge, sharing of information among researchers and students also facilitates discussion with research group members and supervisor or lecturers.

Next, hypothesis number one confirmed that interactive with research group positively and significantly with collaborative learning was ($\beta_3 = 0.213$, $p < 0.001$) Thus, hypothesis H1a has a direct positive and significant effect where there's a significant relationship among interactive with research group and collaborative learning. Hence, allows the exchange of information with group members, increase the knowledge sharing capabilities and facilitates discussion with research group members.

The next, hypothesis number two confirmed that interactive with supervisor positively and significantly with collaborative learning was ($\beta_3 = 0.182$, $p < 0.001$); Hence, hypothesis H2 was supported where there's a significant relationship between interactive with supervisors and collaborative learning. Thus, allows the exchange of information with supervisors or lecturers and facilitates discussion with them.

The next, hypothesis thirteen confirmed that interactive with research group positively and significantly with interactive with supervisor or lecturers was ($\beta_3 = 0.182$, $p < 0.001$) thus, hypothesis H13 has a direct positive and significant effect where there's a significant relationship between interactive with research group and interactive with supervisor or lecturers. Trough, collaborative learning by social media allows the exchange of knowledge, sharing of information among researchers and students also facilitates discussion with research group members and supervisor or lecturers. Findings in Table 2 also the engagement positively and significantly with students and researchers satisfaction was ($\beta_3 = 0.172$, $p < 0.001$); Hence, hypothesis H12 was supported where there's a significant relationship between engagement and researchers' satisfaction. Thus, the researchers and students satisfying when use social media for collaborative learning and engage with research group members and supervisors. The next, hypothesis nine confirmed that collaborative learning positively and significantly with students and researchers satisfaction was ($\beta_3 = 0.154$, $p < 0.001$); Thus, hypothesis H9 was supported where there's a significant relationship between collaborative learning and students and researchers satisfying. Thus, actively exchanged the ideas with research group members and able to develop problem solving skills through group members'

Table 3: Descriptive statistics and correlation matrix

	GM	SU	EN	PE	PU	CL	IU	RS
GM	1							
SU	0.666**	1						
EN	0.679**	0.678**	1					
PE	0.691**	0.670**	0.802**	1				
PU	0.694**	0.682**	0.787**	0.835**	1			
CL	0.700**	0.643**	0.836**	0.861**	0.832**	1		
IU	0.670**	0.696**	0.715**	0.721**	0.728**	0.723**	1	
RS	0.539**	0.596**	0.734**	0.665**	0.682**	0.704**	0.662**	1

** : Correlation is significant at the 0.01 level (2-tailed)

collaboration also facilitates discussion with supervisors and lecturers.

Findings in Table 2 also confirmed that perceived usefulness found positively and significantly with researchers and students satisfying was ($\beta_3 = 0.143$, $p < 0.001$); Hence, hypothesis H6 was verified supported where there's a significant relationship between perceived usefulness with students and researchers' satisfaction that improve performance of the researchers when use social media also the information sharing. The finally hypothesis five also confirmed that perceived ease of use found positively and significantly with researchers and students satisfying was ($\beta_3 = 0.095$, $p < 0.001$); Hence, hypothesis H5 was verified supported where there's a significant relationship between perceived ease of use with students and researchers' satisfaction that also improve academic performance of students and researchers by using of social media.

Table 3 shows the Pearson correlation coefficient at 96% confidence level. The best correlation was found between the perceived ease of use with collaborative learning with correlation coefficient of 0.861. The characters on Table 1 as follows: interactive with research Group Members (GM), interactive with Supervisors (SU), Engagement (EN), Perceived Ease of use (PE), Perceived Usefulness (PU), Intention to Use (IU), Collaborative Learning (CL) and Researchers Satisfaction (RS).

Result of Pearson correlation shows the dependent variable performance of the researchers has positive and significant correlation with researchers satisfaction ($r = 0.806$, $p < 0.01$) that positive and high correlation. correlation results of performance of the researchers with collaborative learning ($r = 0.794$, $p < 0.01$). So the positive and significant correlation with collaborative learning; correlation results of performance of the researchers with engagement ($r = 0.751$, $p < 0.01$); the results of performance of the researchers with interactive with supervisors ($r = 0.665$, $p < 0.01$) and the last correlation results of performance of the researchers with Interactive with research group ($r = 0.664$, $p < 0.01$). These results highlight that performance of the researchers relationship with interactive with research group members, interactive with supervisor, engagement and researchers satisfaction, is contributing to improve performance of the researchers through collaborative learning. In

general, the using social media provides collaborative learning and useful for researchers and using of social media in the research group would enable the researcher to accomplish tasks more quickly, using the social media enhances effectiveness in the researches. Also using social media will be easy to incorporate in the research group, using social media makes it easy to reach group members. So, the researchers satisfaction about using social media for collaborative learning to improve their academic performance the result a high. Also the using social media for collaborative learning to improve performance of the researchers having a medium level through interaction with supervisors because the using social media provides collaborative learning interaction and improve communication skills with supervisor, facilitates interaction with supervisor and allows the exchange of information with supervisor.

The researchers engagement for the using social media for collaborative learning to improve performance of the researchers having a high level through engagement with researchers and supervisor because the using social media provides collaborative learning and engagement among researchers and supervisors. The collaborative learning with social media usage and acquired a high percentage when it comes to performance of the researchers at University. Since it helps make the researchers feel confident enough to presenting the social media by collaborative among researchers also researchers and supervisors that make ease to get resource, more information and knowledge. The collaborative learning experience in the social media environment is better than in a face-to-face learning, the researchers was able to develop research skills through members' collaboration, using of social media and the researchers actively exchanged the ideas with research group members. and the researchers intend to use social media for getting resources from my supervisor, researchers would not mind to switch over to another social media if it has better functionalities, also the researchers intend to use social media to improve the research skills and using of social media to build a researchers-supervisor relationship and this improves performance of research and using of social media and this will improve the research, by using of social media to facilitate academic activities and coordinate with other researchers.

CONCLUSION AND RECOMMENDATIONS

To conclude, the present study proposed the use of constructivist theory and model along with TAM in the context of collaborative learning and engagement through social media. The factors present in collaborative learning and engagement were demonstrated to be the same ones behind technology satisfaction. Both students and researchers that comprised the sample study appeared to be highly interactive and engaged while using social media and eventually they were satisfied. However, students have the urge to control time loss. In this day and age of social media network, the question arises as to how to attract students and researchers satisfied with such networks in the educational field. This research addressed this question-the answer to which may be valuable to researchers and students as it highlights the many uses of social media networks for education and the enhancement of research skills. Future research can build upon the findings of this researcher by investigating other areas and aspects of the topic, increasing sample size and more importantly, focusing on existing social media network and their usefulness in collaborative learning and engagement.

ACKNOWLEDGMENT

This material is based upon work supported by Instructional Development Grant (IDG) and Research University Grant (RUG) Universiti Teknologi Malaysia and the Academy of Sciences for the Development World (TWAS) Research Grant under Vote No. 08216,02J 57 and 10-147 RG/ITC/AS C; UNESCO FR:3240246311. Any opinions, findings and conclusions or recommendations expressed in this material are those from the authors and do not necessarily reflect on the views of the Universiti Teknologi Malaysia and the Academy of Sciences for the Development World; also supported by Faculty of Marine, Hodeidah University, Hodeidah, Yemen.

REFERENCES

- Abdul Hamid, N., M.S. Ishak, S.A. Ismail and S.Y.N. Mohamad Yazam, 2013. Social Media and the New Academic Environment: Pedagogical Challenges-Chapter 12. Social Media Usage among University Students in Malaysia, IGI Global, pp: 244-255.
- Ajjan, H. and R. Hartshorne, 2008. Investigating faculty decisions to adopt Web 2.0 technologies: Theory and empirical tests. *Internet High. Educ.*, 11: 71-80.
- Al-Rahmi, W.M. and M.S. Othman, 2013. The impact of social media use on academic performance among university students: A pilot study. *J. Inform. Syst. Res. Innov.*, 4: 1-10.
- Al-Rahmi, W., M. Othman and M. Musa, 2014. The improvement of students' academic performance by using social media through collaborative learning in Malaysian higher education. *Asian Soc. Sci.*, 10(8).
- Arnold, N. and T. Paulus, 2010. Using a social networking site for experiential learning: Appropriating, lurking, modeling and community building. *Internet High. Educ.*, 13: 188-196.
- Bernard, M., C. Abrami, E. Borokhovski, A. Wade, M. Tamim, A. Surkes and C. Bethel, 2009. A meta-analysis of three types of interaction treatments in distance education. *Rev. Educ. Res.*, 79(3): 1243-1289.
- Chen, B. and T. Bryer, 2012. Investigating instructional strategies for using social media in formal and informal learning. *Int. Rev. Res. Open Distance Learn.*, 13(1): 87-104.
- Chen, P., R. Gonyea and G. Kuh, 2008. Learning at a distance: Engaged or not. *Innov. J. Online Educ.*, 4(3).
- Chen, P.D., A.D. Lambert and K.R. Guidry, 2010. Engaging online learners: The impact of web-based technology on college student engagement. *Comput. Educ.*, 54: 1222-1232.
- Clegg, T., J.C. Yip, J. Ahn, E. Bonsignore, M. Gubbels, B. Lewittes and E. Rhodes, 2013. When face-to-face fails: Opportunities for social media to foster collaborative learning. *Proceeding of International Society of the Learning Sciences, Computer-Supported Collaborative Learning 2013, Madison*, pp: 113-120.
- Cluett, L. and J. Skene, 2007. A new(er) dimension to online learning communities: using web tools to engage students. *Student Engagement. Proceeding of the 16th Annual Teaching and Learning Forum, the University of Western Australia, January 2007*.
- Corrin, L., S. Bennett and L. Lockyer, 2010. Digital natives: Everyday life versus academic study. *Proceeding of the 7th International Conference on Networked Learning, Aalborg Denmark*, pp: 643-650.
- Coyle, C. and H. Vaughn, 2008. Social networking: Communication revolution or evolution? *Bell Labs Tech. J.*, 13(2): 13-18.
- Dabbas, N. and A. Kitsantas, 2012. Personal learning environments, social media and self-regulated learning: A natural formula for connecting formal and informal learning. *Internet High. Educ.*, 15(2012): 3-8.
- Davis, F.D., 1989. Perceived usefulness, perceived ease of use and user acceptance of information technology. *MIS Quart.*, 13(3): 319-340.
- Davis, F., R. Bagozzi and P. Warshaw, 1989. User acceptance of computer technology: A comparison of two theoretical models. *Manage. Sci.*, 35(8): 982-1003.

- Devaraj, S., R. Easley and J. Crant, 2008. How does personality matter? Relating the five-factor model to technology acceptance and use. *Inform. Syst. Res.*, 19(1): 93-105.
- Doll, W. and G. Torkzadeh, 1998. Developing a multidimensional measure of system-use in an organizational context. *Inform. Manage.*, 33(4): 171-185.
- Ebner, M., C. Lienhardt, M. Rohs and I. Meyer, 2010. Microblogs in higher education: A chance to facilitate informal and process-oriented learning? *Comput. Educ.*, 55: 92-100.
- Fewkes, A.M. and M. McCabe, 2012. Facebook: Learning tool or distraction? *J. Digital Learn. Teach. Educ.*, 28(3): 92-98.
- Frye, E.M., W. Trathen and D.A. Koppenhaver, 2010. Internet workshop and blog publishing: Meeting student (and teacher) learning needs to achieve best practice in the twenty-first-century social studies classroom. *Soc. Stud.*, 101(2): 46-53.
- Green, T. and M. Pearson, 2011. Integrating website usability with electronic commerce acceptance model. *Behav. Inform. Technol.*, 3(2): 181-199.
- Hamat, A., M.A. Embi and H. Abu Hasan, 2012a. The use of social networking sites among Malaysian university students. *Int. Educ. Stud.*, 5(3): 56-66.
- Hamat, A., M.A. Embi and H. Abu Hasan, 2012b. Top-performing students' use of social networking sites. *Res. J. Appl. Sci. Eng. Technol.*, 5(2): 361-369.
- Heafner, T.L. and A.M. Friedman, 2008. Wikis and constructivism in secondary social studies: Fostering a deeper understanding. *Comput. Schools*, 25: 288-302.
- Huang, R., J. Yang and L. Zheng, 2013. The components and functions of smart learning environments for easy, engaged and effective learning. *Int. J. Educ. Media Technol.*, 7(1): 4-10.
- Johnson, D.W. and R.T. Johnson, 2008. Social Interdependence Theory and Cooperative Learning: The Teacher's Role. *The Teacher's Role in Implementing Cooperative Learning in the Classroom*. Springer, New York, pp: 9-37.
- Joosten, T., 2012. *Social media for educators: Strategies and best practices*. Hoboken, NJ, Jossey-Bass, USA.
- Junco, R., 2012a. The relationship between frequency of Facebook use, participation in Facebook activities and student engagement. *Comput. Educ.*, 58: 162-171.
- Junco, R., G. Helbergert and E. Loken, 2011. The effect of Twitter on college student engagement and grades. *J. Comput. Assist. Lear.*, 27: 119-132.
- Kim, H., 2008. The phenomenon of blogs and theoretical model of blog use in educational contexts. *Comput. Educ.*, 51(3): 1342-1352.
- Kim, B., 2011. Understanding antecedents of continuance intention in social-networking services. *Cyberpsychol. Behav. Soc. Netw.*, 14(4): 199-205.
- Kim, H.W., H.C. Chan and S. Gupta, 2007. Value-based adoption of mobile internet: An empirical investigation. *Decis. Support Syst.*, 43: 111-126.
- Kim, B., M. Choi and I. Han, 2009. User behaviors toward mobile data services: The role of perceived fee and prior experience. *Expert Syst. Appl.*, 36(4): 8528-8536.
- Landry, B., G. Rodger and S. Hartman, 2006. Measuring student perceptions of blackboard using the technology acceptance model. *Decision Sci. J. Innov. Educ.*, 4(1): 87-99.
- Lee, Y., Y. Hsieh and C. Hsu, 2011. Adding innovation diffusion theory to the technology acceptance model: Supporting employees' intentions to use e-learning systems. *Educ. Technol. Soc.*, 14(4): 124-137.
- Lenhart, A. and M. Madden, 2007. *Social networking websites and teens: an overview*. Research Project Report, Research Center Washington, DC.
- Lepper, M.R., H.J. Corpus and S.S. Iyengar, 2005. Intrinsic and extrinsic motivational orientations in the classroom: Age differences and academic correlates. *J. Educ. Psychol.*, 97(2): 184-196.
- Lim, S., 2009. How and why do college students use Wikipedia? *J. Am. Soc. Inf. Sci. Tec.*, 60(11): 2189-2202.
- Lopping, I.M. and E. McKinney, 2004. Extending the technology acceptance model and the task-technology fit model to consumer E-commerce. *Inform. Technol. Learn. Perform. J.*, 22(1): 35-49.
- Mason, R. and F. Rennie, 2008. *E-learning and Social Networking Handbook: Resources for Higher Education*. 1st Edn., Routledge, New York, ISBN-13: 978-0415426077.
- McLuhan, M., 1962. *The Gutenberg Galaxy: The Making of Typographic Man*. University of Toronto Press, Toronto.
- Merchant, G., 2012. Mobile practices in everyday life: Popular digital technologies and schooling revisited. *Brit. J. Educ. Technol.*, 43(5): 770-782.
- Montgomery, C. and L. McDowell, 2009. Social networks and the international student experience: An international community of practice? *J. Stud. Int. Educ.*, 13(4): 455-466.
- Mora-Soto, A., M.I. Sanchez-Segura, F. Medina-Dominguez and A. Amescua, 2009. Collaborative learning experiences using social networks. *Proceeding of the International Conference on Education and New Learning Technologies*. Barcelona, Spain 2009.
- Paxton, P., 1999. Is social capital declining in the United States? A multiple indicator assessment. *Am. J. Sociol.*, 105: 88-127.
- Rubin, N., 2010. *Creating a User-centric Learning Environment with Campus Pack Personal Learning Spaces*. PLS Webinar, Learning Objects Community, Retrieved from: http://community.learningobjects.com/Users/Nancy.Rubin/Creating_a_UserCentric_Learnig.

- Saeed, N., Y. Yang and S. Sinnappan, 2009. User acceptance of Second Life: An extended TAM with hedonic consumption behaviors. Proceeding of the 17th European Conference on Information Systems (ECIS'09). Verona, Italy, June 8-10, pp: 2963-2975.
- Sampson, D.G., P. Zervas and S. Sotiriou, 2011. COSMOS: A webbased repository of learning designs for science education. *Adv. Sci. Lett.*, 4(11-12): 11-12.
- Selwyn, N., 2010. Looking beyond learning: Notes towards the critical study of educational technology. *J. Comput. Assist. Lear.*, 26(1): 65-73.
- Shoshani, Y. and H. Rose Braun, 2007. The use of the Internet environment for enhancing creativity. *Educ. Media Int.*, 44(1): 17-32.
- Smith, F. and R. San, 2007. *My School, Meet Myspace: Social Networking at School*. The George Lucas Educational Foundation, Edutopia.
- So, H.J. and T.A. Brush, 2008. Students perceptions of collaborative learning, social presence and satisfaction in a blended learning environment: Relationships and critical factors. *Comput. Educ.*, 51(1): 318-336.
- Srite, M., 2006. Culture as an explanation of technology acceptance differences: An empirical investigation of Chinese and US users. *Aust. J. Inform. Syst.*, 14(1).
- Tess, P.A., 2013. The role of social media in higher education classes (real and virtual): A literature review. *Comput. Hum. Behav.*, 29(2013): A60-A68.
- Tombros, A., I. Ruthven and M.J. Joemon, 2005. How users assess web pages for information seeking. *J. Am. Soc. Inf. Tec.*, 56(4): 327-344.
- Venkatesh, V. and F. Davis, 2000. A theoretical extension of the technology acceptance model: Four longitudinal field studies. *Manage. Sci.*, 46: 186-204.
- Venkatesh, V. and H. Bala, 2008. Technology acceptance model 3 and a research agenda on interventions. *Decision Sci.*, 39(2): 273-315.
- Withers, K., 2007. *Young people and social networking sites: Briefing to guide policy responses*. Research Report, Institute of Public Policy Research, London.
- Wixom, B.H. and P.A. Todd, 2005. A theoretical integration of user satisfaction and technology acceptance. *Inform. Syst. Res.*, 16(1): 85-102.
- Yampinij, S., M. Sangsuwan and S. Chuathong, 2012. A conceptual framework for social network to support collaborative learning (SSCL) for enhancing knowledge construction of grade 3 students. *Proc. Soc. Behav. Sci.*, 46: 3747-3751.
- Yu, A.Y., S.W. Tian, D. Vogel and R.C. Kwok, 2010. Can learning be virtually boosted? An investigation of online social networking impacts. *Comput. Educ.*, 55: 1494-1503.