

COMPARISON OF AIR TO AIR AND AIR TO WATER INTERCOOLERS IN THE COOLING PROCESS OF A TURBOCHARGER ENGINE

Henry Nasution^{a,b,*}, Azhar Abdul Aziz^a, Zulkarnain Abdul Latiff^a, Stannely Engkuah^c

^aAutomotive Development Centre, Faculty of Mechanical Engineering, Universiti Teknologi Malaysia, 81310 UTM Johor Bahru, Johor, Malaysia

^bDepartment of Mechanical Engineering, Faculty of Industrial Technology, Universitas Bung Hatta, Padang 25132, Sumatera Barat, Indonesia

^cFaculty of Mechanical Engineering, Universiti Teknologi Malaysia, 81310 UTM Johor Bahru, Johor, Malaysia

Article history

Received

16 January 2015

Received in revised form

24 March 2015

Accepted

15 March 2015

*Corresponding author

henry@fkm.utm.my

Graphical abstract



Abstract

Compressed air from a turbocharger needs to be cooled down to prevent knocking inside the combustion chamber from occurring. In the present study, air to water intercooler is used as a heat exchanger to minimize the temperature rise of the charged air produced from the turbocharger i.e. water is used as the medium for cooling the temperature of the charged air before the intake manifold instead of using direct air, which is the common medium of any intercooling system. The experiments were conducted with engine speeds of 2000, 2500, 3000, 3500, 4000, 4500 and 5000 rpm, with pressure of 0.6, 0.8 and 1.0 bar. The present study found that the air to water intercooler is more efficient and the heat transfer is much better than that of the air to air intercooler. This is due to the air flow to the water inside the intercooler is better compared to the system that uses an air to air intercooler system.

Keywords: Performance, heat transfer, intercooler, air to air, air to water

Abstrak

Udara termampat daripada pengecas turbo perlu disejukkan untuk mencegah kesan 'ketukan' di dalam kebuk pembakaran berlaku. Dalam kajian ini, intercooler bertindak sebagai penukar haba untuk mengurangkan kenaikan suhu udara yang dihasilkan daripada pengecas turbo, dan juga air digunakan sebagai medium untuk penyejukan suhu udara dan bukannya daripada menggunakan langsung udara yang merupakan medium asas sistem penyejukan. Kajian ini telah dijalankan dengan kelajuan enjin tahun 2000, 2500, 3000, 3500, 4000, 4500 dan 5000 rpm dengan tekanan 0.6, 0.8 dan 1.0 bar. Kajian ini mendapati bahawa udara kepada intercooler air adalah lebih cekap dan pemindahan haba adalah lebih baik daripada yang di udara mendatangi intercooler udara. Ini disebabkan oleh aliran udara kepada air di dalam intercooler yang lebih baik berbanding dengan sistem yang menggunakan udara untuk sistem intercooler udara.

Kata kunci: Prestasi, Pemindahan haba, penyejuk dalaman, udara ke udara, udara ke air

© 2015 Penerbit UTM Press. All rights reserved

1.0 INTRODUCTION

An intercooler is one of the components used as a cooling system to cool the compressed air with the thermal activity in the air so that it fits in a given space with less pressure; an intercooler allows the compressor to push in more air to the engine intake manifold for a given boost pressure [1]. An intercooler will increase the mass of air entering the engine. The spark-ignition engine will need to inject more fuel due to the higher mass of compressed air produced from the turbocharger or the supercharger hence the spark-ignition engine can produce more power [2-7].

The intercooler that is used in commercial vehicles applies a basic system that uses an air to air intercooling system. The air temperature from the compression side of a turbocharger is higher and when it flows pass the air to air intercooler system, the temperature difference is small. The air flow into the intake manifold still has the highest temperature. This high temperature air intake can affect the fuel consumption of the vehicle [8].

Intercooling is the term used to describe the process of cooling the compressed air produced at the compressor discharge of the turbocharger before the compressed air is delivered to the intake manifold. An intercooler that acts as the heat exchanger will be installed before the intake manifold. The intercooler is used to cool the temperature of the compressed air and also increases the density of the compressed air before flowing into the intake manifold. By increasing the density of the air, the mass flow rate of the air also increases before entering the intake manifold and further mixed with fuel. A greater air mass flow rate at the intake manifold will allow for a greater quantity of fuel and air mixture to be converted to power.

The high temperature air intake can have negative impacts to engine components. Thermal loadings on engine parts such as valves and pistons will be increased. By reducing the compressed air temperature, the problem of detonation and pre-ignition in spark ignition engines can be reduced or eliminated [1].

Air to water intercooler systems are designed to operate by minimizing the temperature rise of the charged air produced from the turbocharger. An air to water intercooler system consists of an air to water intercooler as the heat exchanger, a pump to deliver the liquid from the reservoir to the liquid core of the air intercooler, a reservoir to store the liquid for the system and an additional heat exchanger for the liquid that circulates in the system. In this study, an experiment will be carried out to acquire the temperature difference data at the inlet and outlet of the air to water intercooler. The data will be used to determine the effectiveness of the air to water intercooler as the heat exchanger in internal combustion engines.

1.1 Air to Water Intercooler Core

The intercooling effect in an internal combustion engine should not only alleviate the temperature rise

from the turbocharging effect, it also needs to change the properties, temperature profiles and air density. Denser air would allow a complete detonation inside the combustion chamber. The fuel injected into the combustion chamber would also burn completely such that the emission problem is reduced. An incomplete detonation process in the combustion chamber will produce gases that deteriorate the environment.

In a forced induction system, the engine has less emissions and lower fuel consumption [9]. The effect of intercooling processes also needs to be improved for the superchargers in internal combustion engines. There are various methods to attain for said improvements such as by installing a staged intercooling process and the turbine expansion process into a spark ignited gasoline engine [10, 11].

There are several types of intercooler designs that have been used in many areas, particularly power plants, marine technologies, automotive technologies, air conditioning systems, etc. The type of intercoolers used for an application is based on the suitability of the intercooler for said application. As an example, for automotive applications, an air to air type intercooler is usually chosen while marine technology often uses water to air intercoolers [12].

Air to water intercoolers are also known as water-cooled intercoolers. This type of intercooler is used in large industrial areas such as in air-conditioning systems for huge buildings, in marine technology and also aerospace technology. The basic water-cooled intercooler consists of several constituents, which are the air cooler section, water-cooler section, heat exchanger for the fluid and also a fluid reservoir.

1.2 Air to Water Intercooler Core

The design of an air to water intercooler is basically of a shell and tube type. The water-cooled intercooler is more suitable for marine engine applications because the position of the engine that is located beneath the ship—underwater. Hence, using sea water as the coolant liquid for the water-cooled intercooler is more efficient if compared to the use of the air to air intercooler system.

The main component of the system is the air to water intercooler. The air to water intercooler needs to be fabricated before it can be installed to the engine. The air to water intercooler is fabricated based on the design parameters that are suitable for the engine such as the size of the intercooler, the position of the intercooler inside the engine bay and the connection of the intercooler from the turbocharger outlet and to the intake manifold. The core of the air to water intercooler used in this system is the finned plate type. Figure 1 shows the core of the liquid to the air intercooler; the charged air will flow pass through this flat tube with an inner fin inside the tube. The inner fin will increase the contact surface area of the hot air that flows through the flat tube. The intercooler is a rectangular type as shown in Figure 2.

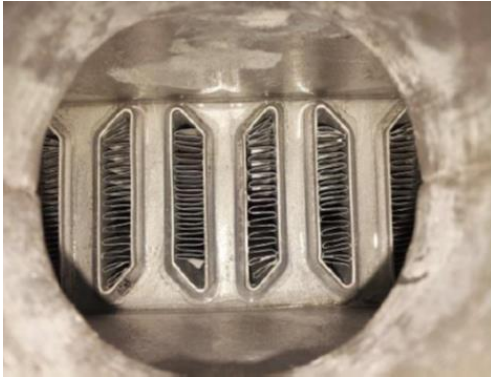

Figure 1 The flat-finned tube

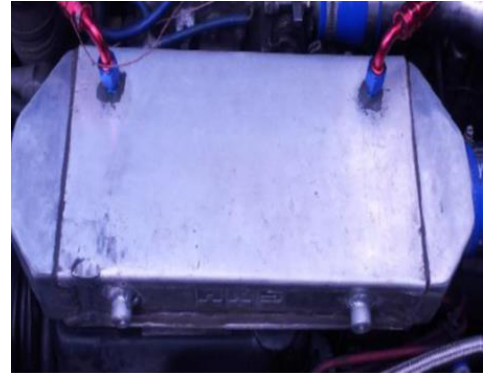

Figure 2 The air to water intercooler

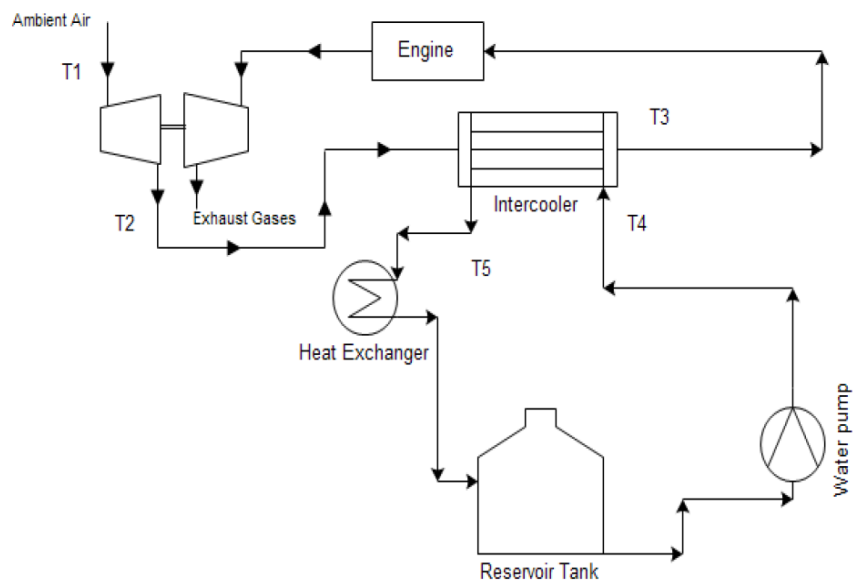

Figure 3 Schematic diagram of the air to water intercooler system

1.3 The Heat Transfer Effectiveness

The important thing to consider in designing a good intercooler is to know the total rate of the heat transferred (q) from one fluid to another fluid. The method used to analyze the heat transfer is by applying the energy balance equation as such:

$$q = \dot{m}c_p\theta \tag{1}$$

where; \dot{m} (kg/s) is the mass flow rate of the fluid, c_p (J/kg.K) is the specific heat at constant temperatures and θ (K) is the temperature difference. The performance of the heat exchanger is essentially related to the total heat transfer rates and quantities

such as inlet and outlet fluid temperatures, the overall heat transfer coefficient and the total surface area for heat transfer. The heat transfer rate for the total hot fluid is:

$$q_a = \dot{m}_h c_{p,h} (T_{h,i} - T_{h,o}) \tag{2}$$

where q_a refers to the charged air heat transfer rate, $T_{h,i}$ is inlet temperature of hot water (°C) and $T_{h,o}$ is outlet temperature of hot water (°C) that flows into the heat exchanger from the cold fluid whereby we have:

$$q_f = \dot{m}_c c_{p,c} (T_{c,i} - T_{c,o}) \tag{3}$$

where q_f refers to the working fluid heat transfer rate,

$T_{c,i}$ is inlet temperature of cold water (°C) and $T_{c,o}$ is the outlet temperature of cold water (°C). From the energy equation and assuming that there are no energy losses between the charged air and the working fluid:

$$q_a = q_f$$

$$\dot{m}_c c_{p,c} (T_{c,i} - T_{c,o}) = \dot{m}_h c_{p,h} (T_{h,i} - T_{h,o}) \quad (4)$$

The intercooler effectiveness (ε) equations are given as:

$$\varepsilon = \frac{q}{q_{max}} \quad (5)$$

where $q_f = q_a = q$

$$q_{max} = C_{min} \theta$$

from Equations 3 and 4:

$$C_h = \dot{m}_h C_{p,h} \quad (6)$$

then

$$\text{If } C_h > C_c, C_c = C_{min} \text{ and } q_{max} = C_c \theta \quad (7)$$

$$\text{If } C_c > C_h, C_h = C_{min} \text{ and } q_{max} = C_h \theta \quad (8)$$

where q_{max} is maximum heat transfer rate, C_h is heat capacity for hot water (W/K), C_c is heat capacity for cold water (W/K), C_{min} is minimum heat capacity.

2.0 EXPERIMENT SETUP

The experimental testing rig was developed with all the components required for the air to water intercooler system. The components of the air to water intercooler system will be installed in an engine before acquiring the measurement data. To compare the performance of the engine, which is one of the purposes of this project, the standard air to air intercooler is used and that obtained data will be used as the reference data for a standard engine performance.

The engine used for the experiment is a Daihatsu Mira L200 turbocharger engine that is installed in a Perodua Kancil with displacement = 659 cc, Max. Power (Net), kW (PS)/rpm = 64 PS (47.07 kW)/7500 rpm, Max. Torque (Net), N.m (kg.m)/rpm = 9.4 kg.m (92.18 N.m)/4000 rpm with an electronic fuel injection system. The K type thermocouple is used in this experiment. The thermocouple type has a suitable range of operation temperature between -200°C (-328 °F) to 1250°C (2282°C). This type of thermocouple

has a standard limit of error that is 2.2°C or 0.75%. Data logger (TC-08 Pico Logger) is connected to the terminal of the thermocouple, so that all the temperature readings made by the thermocouple will be saved in the computer under the Pico Log Recorder. A precautionary step that should be taken when using the thermocouple data logger is that the equipment should be covered by a box because the maximum allowable operating temperature of the equipment is only 50°C.

The schematic diagram of the air to water intercooling system is developed based on the respective purpose of each component of this system. The position of the measured parameter is determined based on the parameters needed in defining the relevant mathematical equations that are used to analyze the effectiveness of the heat exchanger and the performance of the engine. The data acquisition system is installed on the system as such the pressure transducer is used to monitor the pressure inside the system and the data acquisition system is used to measure the inlet and outlet temperatures of the air to water intercooler. Figure 3 shows the schematic diagram of the experimental apparatus arrangements on the engine.

A water pump is used to deliver the cold water into the air to water intercooler from the reservoir tank. The pump is supplied with a 12 volts (direct current) power supply to allow the pump to work compatibly with the current supply inside the electrical systems of the car. The size of the pump must be suitable with the location where the pump is to be mounted.

The thermocouples are placed at the inlet and outlet of the intercooler in the hot section of the fluid. For the air to air intercooler, the thermocouples are placed at the front and the back of the intercooler in the cold section of the fluid, meanwhile for the air to water intercooler the thermocouples are placed at the inlet and outlet of the cooling fluid that is water. Figure 4 shows the thermocouples installed on the air to air intercooler while Figure 5 shows the inlet and outlet water flows of the intercooler. Experimental test conditions are as follows:

1. The intercooler system is running on air and water as a cooling medium.
2. The pressure of the turbocharger was set to 0.6 bar.
3. The system was tested by varying the speed from 2000, 2500, 3000, 3500, 4000, 4500 and up to 5000 RPM under typical load; simulating a car operating on a highway (varying loads).
4. After the data for 0.6 bar was collected, the pressure was increased to 0.8 bar and 1.0 bar boost pressure.
5. The air to air intercooler was compared with the air to water intercooler. The intercooler system was also tested with pressure varied from 0.6, 0.8 and 1.0 bar pressure.

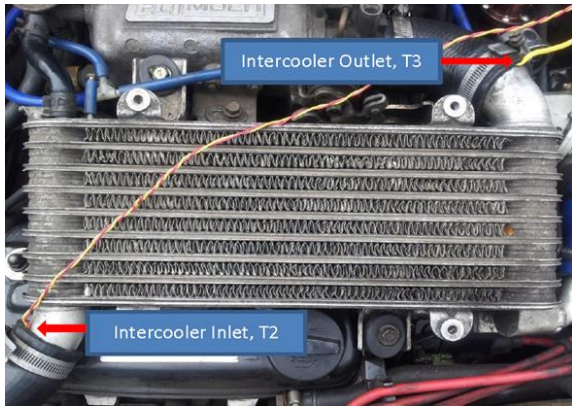

Figure 4 Thermocouple position in air to air intercooler

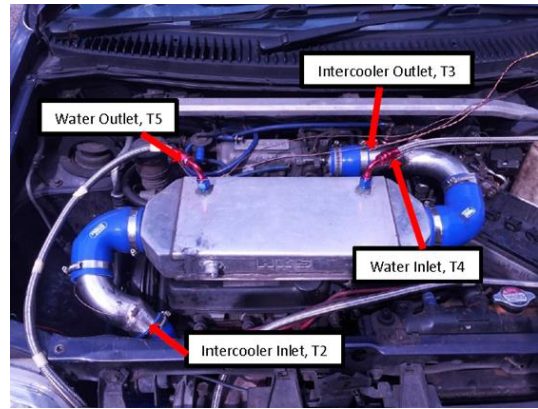

Figure 5 Thermocouple position in air to water Intercooler

3.0 RESULTS AND DISCUSSION

3.1 Effect of Turbocharger Pressure to Temperature Distribution

Figure 6 shows that the temperature of charged air coming out from the turbocharger compressor section increases when the engine speed is increased. The air enters the inlet of the turbocharger at the ambient temperature. When the air is charged to the working pressure of the turbocharger, the temperature of the charged air will be increased higher than the ambient temperature. The figure also shows that at high engine speeds the temperature of the charged air is higher than the temperature of the charged air at lower engine speeds. The charged air temperature is higher at pressure 1.0 bar compared to the temperature at 0.6 and 0.8 bar of boost pressures. The turbocharger will spin at high speeds when the engine speed is increased until it reaches the maximum setting of specific pressure. The high speed rotation of the turbocharger blade fin will cause an increase in air pressure inside the system.

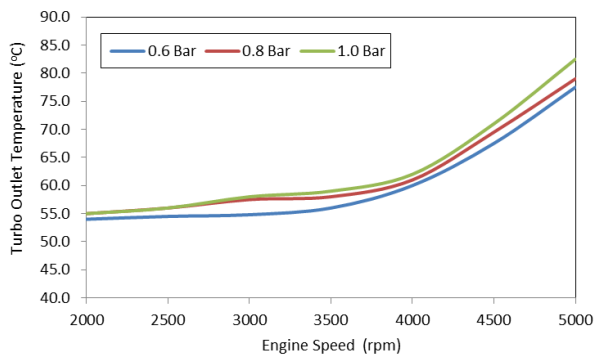

Figure 6 Turbo outlet air temperature distribution related to pressure against the engine speed

From Figure 6, it also shows that the difference in temperature distribution at the lower speed of the engine is small for each specific pressure. The temperature differences become higher when the

speed of the engine is increased. The turbo fin blade starts to rotate with higher speeds to produce high pressure in the system. At the condition where the turbocharger is under the operational speed, the temperature of the charged air is affected by the increase of the temperature in the exhaust system of the engine.

3.2 Effect of Engine Speed to Intercooler Efficiency

Figure 7 shows the intercooler efficiency difference against engine speed for air to water intercooler and air to air intercooler. The graph shows that the air to water intercooler is more efficient compared to the air to air intercooler. The figure also depicts that the intercooler efficiency decreases when the engine speed is increased. This happens because, when the engine is running at high speeds, there will be temperature rises at the inlet of the intercooler and the intercooler needs to transfer the heat more effectively.

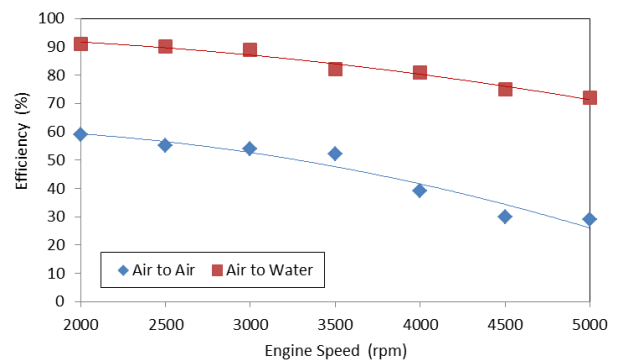

Figure 7 Efficiency between air to air and air to water intercooler

3.3 Air Density Change

Figure 8 shows the difference in air densities for air to air intercooling and air to water intercooling systems. The air density decreases when the engine speed is

increased. The air density profile depends on the temperature and pressure of the charged air. When the engine speed is increased, the pressure and temperature of the system will also increase until it reaches the specific pressure. The decreasing of the air density is high when using the air to air intercooler system whereas the decreasing air density is small when using the air to water intercooler system. This is because of the cooling effect for each intercooler is different. The air to water intercooler can lower down the temperature effectively compared to the air to air intercooler. The figure also shows that the difference in the air density flows is high.

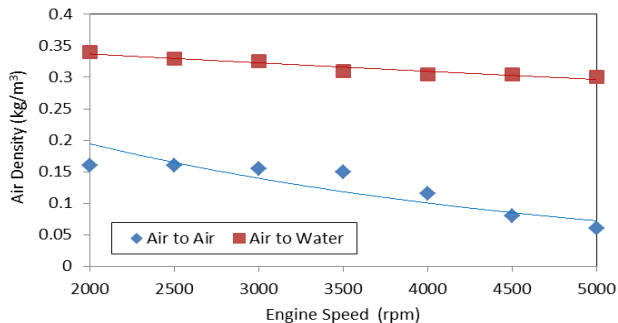

Figure 8 Air densities between air to air and air to water intercooler

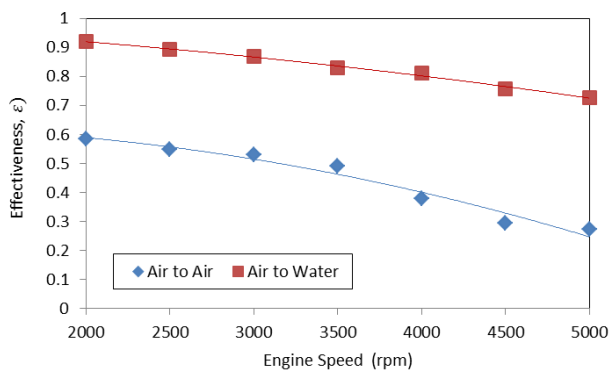

Figure 9 Air density between air to air and air to water intercooler

3.4 Intercooler Effectiveness

The effectiveness of the intercooler is different for each system. Figure 9 shows that the effectiveness of air to water intercooler system is higher compared to the air to air intercooler system. The heat transferred from the charged air flowing through the core of the air to water intercooler is more efficient. The effectiveness value for the air to water intercooler is in the range of 1.0 to 0.7 and the effectiveness value for air to air intercooler is between 0.6 and 0.2. When the speed of the engine is increased, the effectiveness of the intercooler is decreased due to the increase of the temperature from the turbocharger. The effectiveness of the intercooler is affected by the temperature difference inside the

intercooler system, where the higher the temperature, the lower the effectiveness of the system.

4.0 CONCLUSIONS

The experiment has been done successfully and achieved its objective, which is to study the design of air to water intercooler and the heat transfer performance. From this experiment, we can conclude that when the speed of the engine is increased, the temperature profile of the air flowing through the system to the intake manifold also increased. The change in temperature also affects the properties of the air such as density and pressure. By cooling the temperature of the air flowing to the intake manifold, we can increase the density of the air. This is to ensure complete burning of the fuel inside the combustion chamber and thus increases the performance of the engine. On the other hand, the change in the maximum pressure of the turbocharger of an internal combustion engine also leads to the increase in temperature and decrease in density of the flowing air supply to the combustion chamber.

In this experiment, we can also conclude that the system that used the air to water intercooler is more efficient than the air to air intercooler. This is because, the heat transferred from the air flow inside the intercooler to the water is much better compared to the system that used the air to air intercooler system. Therefore, the outlet temperature of the intercooler will be affected by the medium of the cooling fluid.

References

- [1] J. Hartman. 2007. *Turbocharging Performance Handbook*. MBI Publishing Company, Minneapolis.
- [2] J. Chauvin, G. Corde, C. Vigild, N. Petit, P. Rouchon. 2006. Air Path Estimation on Diesel HCCI Engine. *Proceeding of the SAE Conference 2006*. No. 2006-01-1085.
- [3] P. Andersson, L. Eriksson. 2001. Air-to-cylinder Observer on a Turbocharged SI Engine with Wastegate. *Proceeding of the SAE Conference 2001*. No. 2001-01-0262.
- [4] M. Nyberg, T. Stutte. 2004. Model Based Diagnosis of the Air Path of an Automotive Diesel Engine. *Control Engineering Practice*. 12: 513-525.
- [5] P. L. Perez, A. L. Boehman. 2010. Performance of a Single-Cylinder Diesel Engine Using Oxygen Enriched Intake Air at Simulated High-Altitude Conditions. *Aerospace Science Technology*. 14: 83-94.
- [6] S. G. Nieto, J. Salcedo, M. Martinez, D. Lauri. 2009. Air Management in a Diesel Engine Using Fuzzy Control Techniques. *Information Sciences*. 179: 3392-3409.
- [7] A. Uzun. 2012. A Parametric Study For Specific Fuel Consumption of an Intercooled Diesel Engine Using a Neural Network. *Fuel*. 93: 189-199.
- [8] P. Bronnick, R. Pearson, D. 2012. Winterbone, Intercooler Model for Unsteady Flows in Engine Manifolds. *Journal of Automobile Engineering*. 2: 119-132.
- [9] S. Darici, M. Ozgoren. 2010. Intercooler Effect on Conventional Supercharging Systems. *Proceeding of the International Scientific Conference, Gabrovo*. II-242-II-248.

- [10] G. A. Thomson, D. J. Pratley, D. A. Owen. 1987. Intercooling and Regenerating the Modern Marine Gas Turbine Propulsion System. Sae Papers 871379.
- [11] S. Yang, L. S. Wang. 2008. Modeling of Two Charge-air Cooling Turbo-charging Systems for Spark Ignition Engines, 2008 SAE International Powertrains. *Fuels and Lubricants Congress*. 2008-01-1702.
- [12] J. R. Serrano, F. J. Arnau, V. Dolz, A. Tiseira, M. Lejeune, N. Auffret. 2008. Analysis of the Capabilities of a Two-Stage Turbocharging System to Fulfill the US2007 Anti-Pollution Directive for Heavy Duty Diesel Engines. *International Journal of Automotive Technology*. 9(3): 277-288.