

MODELING AND VALIDATION OF ELECTRONIC WEDGE BRAKE MECHANISM FOR VEHICLE SAFETY SYSTEM

Vimal Rau Aparow^{a*}, Khisbullah Hudha^a, Fauzi Ahmad^b, Hishamuddin Jamaluddin^c

^aDepartment of Mechanical Engineering, Faculty of Engineering, National Defense University of Malaysia, Kem Sungai Besi, Kuala Lumpur, Malaysia

^bDepartment of Automotive Engineering, Faculty of Mechanical Engineering, Technical University of Malaysia Malacca, 76109, Durian Tunggal, Malacca, Malaysia

^cDepartment of Applied Mechanics and Design, Faculty of Mechanical Engineering, Universiti Teknologi Malaysia, 81310 UTM Johor Bahru, Johor, Malaysia

Article history

Received

29 March 2014

Received in revised form

23 January 2015

Accepted

15 June 2015

*Corresponding author
vimalrau87vb@gmail.com

Graphical abstract

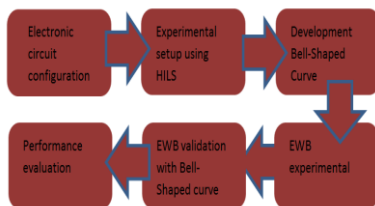

Abstract

This paper presents the performance characteristic of an electronic wedge brake (EWB) mechanism for a vehicle braking system. Based on a Gaussian cumulative distribution method, a non-parametric model, using Bell-Shaped curve method has been proposed in this study to characterize the behavior of an actual EWB mechanism. Therefore, a brake test rig has been developed to investigate the performance of the Bell-Shaped curve model. For the purpose of validation of EWB, an electronic control unit (ECU) which consists of microcontroller unit (MCU), H-Bridge driver and opto-coupler is designed to control the EWB's pinion according to the given rotational input during the experiment. The response measured throughout the experiment is the gapping displacement of the brake piston, clamping force and also brake torque of the EWB mechanism. The responses of the actual EWB mechanism obtained from the experiment are compared with the proposed Bell-Shaped curve. The result of the study shows that the response of the Bell-Shaped curve model closely follows the response of a real EWB actuator in term of clamping force and brake torque with percentage of errors less than 10%.

Keywords: Electronic wedge brake, bell-shaped curve, electronic control unit, clamping force, brake torque

Abstrak

Kajian ini membentangkan ciri persembahan mekanisme brek baji elektronik untuk sistem pembrekan kenderaan. Berdasarkan kaedah taburan longgokan Gauss, satu model *non-parametric*, yang menggunakan kaedah lengkung bentuk loceng telah dicadangkan dalam kajian ini untuk mencirikan perilaku mekanisme EWB yang sebenar. Lantarannya, pelantar minyak ujian brek telah dibangunkan menyiasat prestasi lengkung bentuk loceng model. Untuk tujuan pengesanan EWB, unit kawalan (ECU) elektronik yang terdiri daripada unit mikropengawal, *H-Bridge* dan pengganding optik direka bentuk untuk mengawal pinan EWB mengikut input berputar semasa eksperimen itu. Perilaku yang diukur di seluruh eksperimen ialah sesaran *gapping* ombok brek, kuasa pengapit dan juga daya kilas brek bagi mekanisme EWB. Hasil perbandingan di antara mekanisme EWB sebenar dengan persamaan lengkungan dari eksperimen dibandingkan ditunjukkan di kajian ini. Keputusan kajian menunjukkan bahawa lengkung bentuk loceng dapat mencirikan perilaku penggerak EWB sebenar dengan peratusan kesilapan kurang daripada 10%.

Kata kunci: Brek baji elektronik, lengkung bentuk loceng, unit kawalan electronik, kuasa pengapit, daya kilas brek

© 2015 Penerbit UTM Press. All rights reserved

1.0 INTRODUCTION

Hydraulic brake is a conventional braking system which is commonly used in modern vehicles. Recently, automotive researchers have discovered the disadvantages of using conventional hydraulic brake system in current vehicle. This type of braking system may leads to leakage and vaporization of hydraulic fluid at high temperature which will cause major problems such as hydraulic brake failure [1]. Furthermore, hydraulic brake can also increase automobile environmental effect such as fluids elimination and contribute to fuel depletion [2]. Hence, researchers start to concentrate in developing new type of braking mechanism to replace the existing system. They started to invent a braking mechanism using electronic and mechanical system without any hydraulic components [3].

Considerable works have been carried out theoretically and experimentally by automotive researchers. As a solution of their researches, a new type of braking mechanism known as electronic wedge brake (EWB) has been developed based on brake-by-wire concept [4]. This EWB mechanism is invented to eliminate critical components such as brake booster and cylinders, master cylinder, hydraulic line and ABS control unit [5]. By avoiding all these components, the overall brake system can be developed more economically and easy to install in a vehicle [6]. This will reduce the weight of the brake unit system with a simplified service, greater reliability and more safety for the vehicle [7]. Meanwhile, EWB also requires less engine compartment and chassis space and can avoid interaction with intake manifold of the engine [8]. For an active braking system, the misunderstood of brake pedal pulsations during conventional anti-lock braking system (ABS) function activated can be reduced completely [9].

Although EWB is designed to replace the hydraulic brake system, a proper testing procedure is essential to investigate the performance of EWB actuator before the implementation stage. An experiment based on simulation technique is proposed in order to investigate the performance of an EWB actuator. This is mainly because automotive researchers concern more on safety, costing, repeatability and also capability to reduce damage issues occurred during experiment. Hence, a well-known testing method, hardware-in-the-loop (HIL) experiment is used to investigate the performance of EWB actuator. This testing system has been used widely in automotive industry since this method has high potential to enhance convenience and also reduce cost [10]. However, appropriate components and configuration need to be implemented during the EWB actuator testing using HIL in order to represent the actual automotive environment condition.

Previous researchers have evaluated the performance of an EWB attached with proper test stand and tested using MATLAB/Simulink and dSPACE [2, 9, 11]. Meanwhile, other researchers [7, 12] have

investigated the behavior of EWB actuator which is attached with EWB test bench using MATLAB/Simulink with xPC Target rapid prototyping computer with a CAN data bus interface card. Besides, [13] also studied the EWB behavior using integrated measurement and control (IMC) device but has neglected the automotive environmental and components during testing of the EWB actuator. In this study, EWB actuator developed by [13] is used to investigate the EWB actuator behavior by including all the required components such as floating EWB actuator, rotating inertia of flywheel, brake pad and brake caliper during the experimental stage. The HIL experiment is conducted to study the behavior EWB actuator in actual condition using National Instrument (NI) data acquisition card interface with MATLAB/Simulink and xPC Target.

A few methods have been proposed by previous researchers to describe the actual behavior of EWB actuator in a linear mathematical model [14]. Meanwhile, a non-linear mathematical is used as a model to represent the EWB characteristic [15, 16]. Based on the previous researchers' works, non-linear mathematical model is proposed to represent the behavior of EWB actuator. This mathematical model is developed using one of Gaussian cumulative distribution technique, known as Bell-Shaped curve to represent the behavior of a real EWB actuator. The model is developed using linear displacement response from real EWB actuator as an input to develop the Bell-Shaped curve model. The proposed mathematical model is then validated using clamping force and brake torque obtained from the HIL characteristic experiment using a real EWB actuator.

This paper is organized as follows: The first section contains introduction and review on previous works on design and performance of electronic wedge brake. The second section introduces the design of EWB and the electronic circuits design used to control EWB. The third section presents the EWB test rig and the necessary instrumentation for testing the performance of the EWB system. The experimental procedures used hardware-in-the-loop simulation (HILS) technique to evaluate the characteristic of the proposed EWB system are also described in this section. The experimental results of EWB actuator and validation between the proposed mathematical model using Bell Shaped curve and experimental results of EWB actuator are presented in the fourth section. The last section presents the conclusions.

2.0 ELECTRONIC WEDGE BRAKE ACTUATOR

In this study, electronic wedge brake (EWB) system is represented by the combination of two mechanisms using mechanical and electronic hardware. The mechanical hardware represents the electronic wedge brake actuator itself meanwhile electronic control unit (ECU) represents the electronic hardware of the system. The following section presents the

detailed design of the proposed electronic wedge brake actuator. Then, the study discuss on the ECU design which includes microcontroller unit (MCU), H-Bridge driver and also opto-coupler. The ECU circuit is configured using these major components as mentioned above to control the EWB actuator.

2.1 EWB Design

Electronic Wedge Brake (EWB) was developed as an initial prototype based on the modification of the existing brake caliper in automotive industries as shown in Figure 1. Figure 1 shows the combination of brake caliper, brake pad, a DC motor and also a gearbox with a real EWB actuator. Brake caliper and brake pad is connected in front of EWB actuator and DC motor is attached on top of the EWB actuator to control the motion of EWB's brake piston.

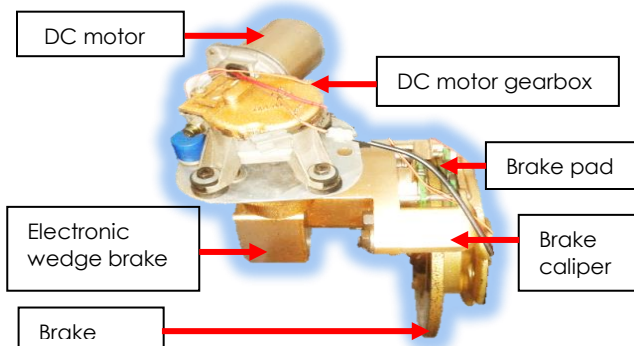

Figure 1 Prototype of electronic wedge brake actuator

Figure 2 shows the computer aided design (CAD) layout of the interior design of the EWB actuator. This interior design of EWB shows the type of components used to assemble the brake mechanism.

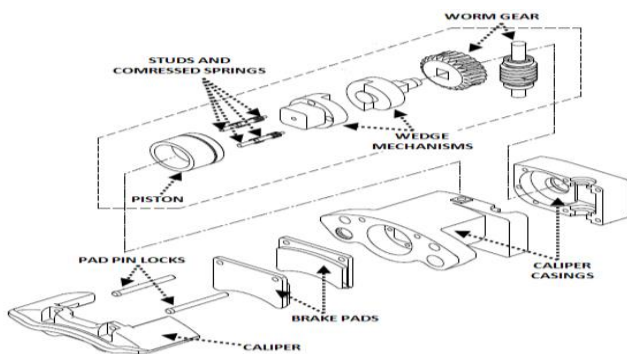

Figure 2 Interior design of EWB actuator [13]

The EWB model prototype is controlled using DC motor where the motor drives the input through a pinion. The displacement of the worm pinion is rotational motions either forward or reverses direction¹³. The rotational displacement of the worm pinion is redirected to the worm gear reducer in order to produce the clamping force to the brake caliper. The worm gear reducer is mounted with the first

wedge mechanism. Backlash between gears can be ignored since it only occurs in one way motion although it involves both left and right rotational movements. The first mechanism is designed with a piston mounting and placed in between a cavity boundary. The cavity boundary is designed at the middle of the caliper by merging with the casing in a square shape [13]. This will allow the second wedge mechanism to slide in linear motion without involving rotational motion from the first wedge. In order to reduce shear friction in between wedge mechanism and cavity walls, studs are added to piston in line with cavity boundary. The linear displacement will allow the piston to produce force at the brake caliper.

2.2 Electronic Control Unit (ECU) Design

Electronic control unit is the main system to operate the DC motor by controlling the EWB actuator. The interior design of ECU is based on minimum system of microcontroller unit (MCU) and motor driver circuit¹⁷. The MCU is installed based on the microcontroller minimum system (minsys) circuit. The minsys refers to the minimum circuit configuration in order to operate MCU properly. The minimum circuit system provides necessary input or output (I/O) port to support the MCU. The output port from MCU will provide signal to drive the motor. However, the signal obtained from MCU alone cannot directly control the motor because the current is very low. Hence, motor driver circuit will act as current buffer for the MCU to drive the DC motor.

(a) Microcontroller Unit (MCU)

Microcontroller Unit (MCU) is the main brain to control electronic wedge brake (EWB) actuator and ATMEGA 32 was proposed as the microcontroller unit (MCU). The reason of choosing this type of microcontroller is because it is readily available in the market with many features to control motor drives and there is also open source software that can be used to program the ATMEGA 32 chip. It is an 8 bit microcontroller device composed of standard on chip peripheral including, 32KB of programmable flash memory, 2KB SRAM, 1KB EEPROM, an 8-channel 10-bit A/D converter, 32 programmable I/O lines, real-time counter, four PWM channel, programmable serial USART, Master/ Slave SPI interface, programmable watchdog timer, external & internal interrupt, and a JTAG interface for on-chip debugging [18].

This microcontroller also supports 16 MIPS at 16 MHz and well operates in between 4.5 to 5.5 volt. Based on these features, this chip should provide enough computing and resources power for the brake-by-wire system. This circuit is packed partially according to the requirement of a brake-by-wire system for the EWB. It consists of voltage regulator, 32 pin I/O port, Serial RS-232 communication, 16 MHz clock, and AVR_ISP connector [18]. In the ATMEGA board, PA_CON, PB_CON, PC_CON, PD_CON are the I/O port pins. Serial communication connector is used as an optional

data logger where it can send data from sensor to the computer via serial RS-232 communication. AVRISP connector is used to compile the program needed by the system inside the microcontroller chip.

(b) Motor Driver Circuit (MDC)

Electronic wedge brake mechanism needs a DC motor that can rotate both in the left and right directions to control EWB's piston which is connected to a second wedge mechanism. Based on this requirement, H-Bridge circuit is proposed to provide and control the rotation of motor in both directions[17]. This circuit can be developed using 2 sets of MOSFET which will act as a switch for H-Bridge as shown in Figure 3.

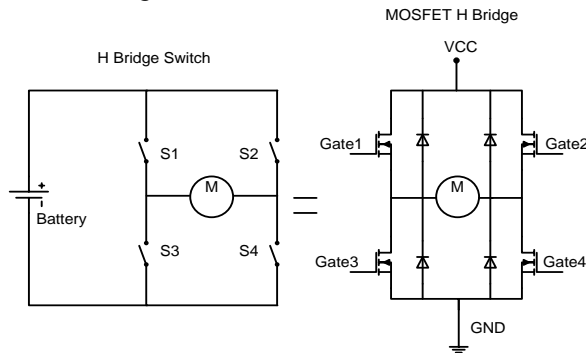

Figure 3 H-bridge circuit

The mechanism of H-Bridge driver works when two MOSFET (S1 and S4) are turned on and the other two MOSFET (S2 and S3) are off. This system will allow the current to flow through the DC motor from S1 to S4 and turns the DC motor in forward direction. In order to rotate the motor in reverse direction, the switching of MOSFET will operate in opposite direction by turning on S2 and S3 and turning off S1 and S4. The MOSFET can be turned on/off by supplying voltage to the "GATE" which is known as MOSFET switch trigger while the diode functions as back EMF protection generated by the DC motor in the H-Bridge. Before developing a motor driver circuit, it is necessary to identify the current requirement for the DC motor. Suitable components can be identified based on the current requirement of the DC motor. In this study, technical parameters of the DC motor are given in Table 1 is used to control the EWB to produce rotational input.

Table 1 Technical parameters of DC motor

Technical Parameters	
Nominal voltage	12 VDC
Nominal power	50 W
Nominal current	1.0 - 1.5 A
High speed	70-75 rpm
Low speed	50 rpm
Working Torque	5 Nm
Braking Torque	26 Nm

The current requirement of DC motor (I) can be obtained using

$$I=P/V \quad (1)$$

where V = voltage and P = power. Based on equation (1), the current requirement for the DC motor can be identified. Thus, a suitable MOSFET such as IRF 1404 and IRF 4905 is used for the switching component of H-Bridge. These MOSFETs are high speed N channel and P channel which are suitable for automotive application. The MOSFET's largest drain is 202 A with 333 W power dissipation and also readily available in the market. These MOSFETs are combined with the fast switching speed, extremely efficient and reliable device, thus suitable for automotive applications.

(c) Opto-isolator

Opto isolator or also known as opto-coupler, photo-coupler or optical isolator is referred to an electronic device which is designed to transfer electrical signals via light waves. It means the opto isolator connected with other circuits without making direct connection. The utilization of light waves is to provide coupling with electrical isolation between both output and input. The opto isolator is designed to prevent high or rapidly changing voltages on one side of a circuit from damaging components on the other side. In this study, opto isolator 4n25 is proposed as the bridge between microcontroller (MCU) and H-bridge driver circuit. This type of opto isolator is proposed as the bridge because it can avoid high voltage from the driver circuit that can damage the microcontroller if there is any short circuit during experiment.

2.3 Circuit Configuration

In the circuit, there are four I/O ports known as PORT A, PORT B, PORT C and PORT D. PORT A of the microcontroller unit was programmed to function as analog to digital converter (ADC) input to read the position from potentiometer sensor data. Meanwhile, PORT B and PORT C function as output to give signal to MOSFET in H-Bridge. A safety design was developed in between microcontroller unit and H-Bridge driver using opto coupler. This opto coupler operates by isolating the microcontroller unit from the H-Bridge via light signal. This light signal will ensure that there is no direct electrical connection in between H-Bridge and microcontroller unit. The supply voltage between microcontroller unit and H-Bridge driver must be separated to ensure opto coupler will isolate both systems. The separation between both systems will make the microcontroller better protected against disturbance like voltage spike which is generated by the motor. Figure 4 shows the circuit configuration of microcontroller, H-Bridge driver and opto coupler and Figure 5 shows the components used for circuit development.

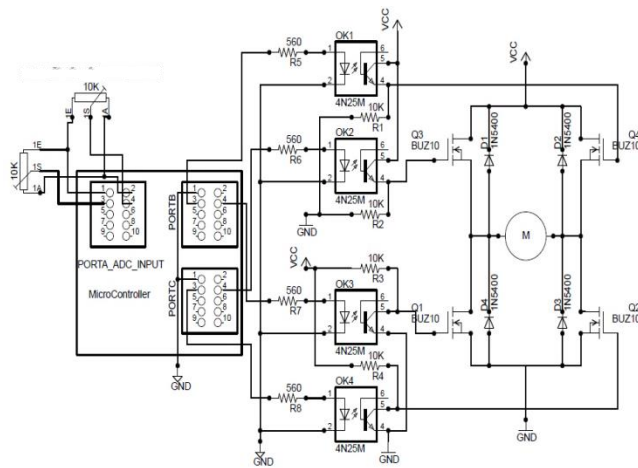

Figure 4 Circuit configuration using microcontroller unit and motor driver



Figure 5 EWB electronic components

3.0 EXPERIMENTAL SETUP FOR EWB

By defining the initial gap existed in-between the brake pads and brake piston and at the same time measuring the real time piston's displacement, the gap between both brake piston and brake pads can be calculated. The measurement of the clamping force produced by the EWB actuator can be obtained from the force sensor. Brake piston of EWB actuator is attached to the force sensor in order to deliver the force during clamping mode. Based on the clamping force, torque produce by the EWB actuator can be calculated using brake torque equation which will be discussed in the next section.

The experimental setup shown in Figure 6 represents the hardware-in-the-loop (HIL) technique to interlink between hardware and software. In this study, HIL was used to obtain the characteristic of the EWB actuator using rotational input from pinion. HIL technique can be divided into two parts, namely software and hardware parts. Software part includes signal interface between Target PC and HOST PC, xPC TARGET and Real-Time Workshop software to control DC motor and potentiometer sensor while Visual Studio 2009 Express used as a C compiler for xPC TARGET [19].

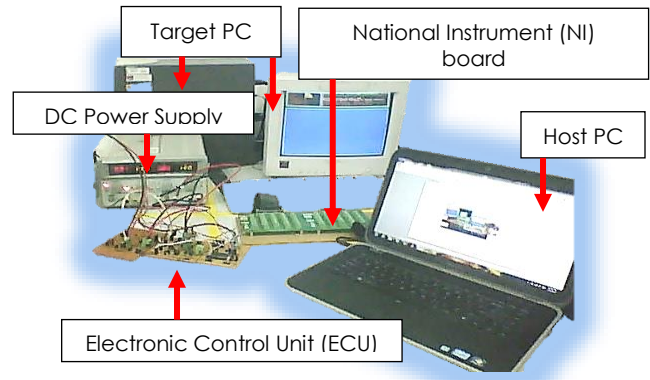

Figure 6 HIL setup using xPC TARGET and Real Time Workshop

As shown in Figures 6 and 7, components such as electronic wedge brake actuator, mechanical coupling, DC motor, electronic control unit (ECU), potentiometer, LVDT, data acquisition PCI card, PCI-based network card, crossover network cable, Host PC, Target PC, National Instrument (NI) board, DC power supply are categorized as hardware for the HIL preparation. After the experimental test rig has been setup, the simulation model was compiled in C code (REAL-TIME WORKSHOP). C code was generated on HOST PC and the code was downloaded to the Target PC using crossover network cable in TCP/IP communication.

The xPC TARGET control the generation of C code from the REAL-TIME WORKSHOP to be deployed into real time operating system capable of running on standard PC hardware. The generated C code in Target PC can be executed using xPC TARGET which is interfaced with the Host PC [19]. Pin out cable is used as the mediator between data acquisition card in the Target PC and National Instrument (NI) board. This board was used for input/output and analogue/digital connections to the actuator and sensor. The wiring of the sensors and DC motor were connected to the NI board for output/input signal interface.

With a host computer running xPC TARGET, MATLAB/Simulink, REAL-TIME WORKSHOP, and a C compiler as the development environment, real-time EWB characteristic can be generated and run on the Target PC using xPC TARGET real-time kernel. After the Target PC interlinked with hardware, the actuator can then be simulated in real time. Figure 7 shows the real-time simulation block diagram started from a predefined total angle rotation of EWB actuator pinion.

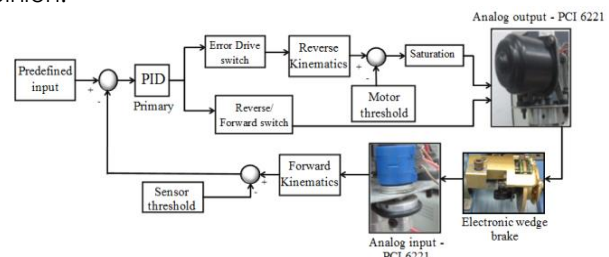

Figure 7 Control structure for EWB HIL experiment

The experiment is initiated with a constant rotational input from the 3-phase permanent magnet motor to the shaft which is attached with a flywheel and brake disc. The motor is disengaged from the shaft once the shaft reaches a constant rotational speed. Then, rotational input is given to the DC motor through the MATLAB XPC TARGET to rotate the pinion. The rotational movement of pinion actuates the brake piston in a linear direction to clamp the brake disc. The rotational input from the DC motor is stopped once the brake disc halt from rotational motion. The output response from the experiment is collected using force sensor and LVDT sensor.

The output responses for constant rotational displacement input from the DC motor are gathered in forms of clamping force response and brake piston displacement of the EWB. The brake torque response is calculated by developing mathematical equation in MATLAB/Simulink software based on the clamping force reading. The tests were repeated several times and the average results are taken in order to get a reliable result. Meanwhile, brake piston displacement response is used to develop a non-linear mathematical equation, Bell-Shaped curve to represent the behavior of real EWB actuator.

4.0 MODELING OF EWB ACTUATOR USING BELL-SHAPED CURVE

Software-in-the-loop (SIL) simulation has been used to develop and analyze the characteristic of the proposed non-linear mathematical model, Bell-Shaped curve (mechanical modeling) and also the DC motor model (electrical model). The following section describes the mathematical equations of both Bell-Shaped curve and DC motor model.

4.1 DC Motor Model

SIL is used to develop an open loop control using DC motor model where the DC motor model is represented [14]

$$V = L \frac{di}{dt} + RI + k_b \dot{\theta} \quad (2)$$

$$M \ddot{\theta} + v \dot{\theta} = k_T I - \tau \quad (3)$$

where V is the voltage applied to the dc motor, L is the motor inductance, R is the motor windings resistance, I is the current through the dc motor windings, k_b is the motor's back electro magnetic force constant, k_T is the motor's constant torque, $\dot{\theta}$ is the shaft's angular velocity, M is the shaft's moment of inertia, v is the viscous friction constant of motor and τ is the torque applied to the shaft by an external load. The rotational displacement, θ , of the DC motor's shaft is identified by integrating the angular velocity, $\dot{\theta}$.

The rotational displacement is used as an input to obtain piston gap by using second order polynomial equation²⁰. The output response from Equation (4) is used to transform piston gapping to clamping force

using non-linear mathematical model, Bell-Shaped curve model.

$$x = (3.8 \times 10^{-9}) \theta^2 + (1.5 \times 10^{-6}) \theta - 0.00084 \quad (4)$$

4.2 Bell-Shaped Curve Model

Based on the EWB experimental response, a mathematical equation is developed to represent the actual clamping force and brake torque of EWB actuator. The linear displacement response from LVDT sensor is used as the input of the mathematical model. The behavior of real EWB actuator can be modeled by using one of the Gaussian cumulative distribution curve which is known as Bell-Shaped curve. The Bell-Shaped curve is proposed to be the mathematical representation since this equation is able to represent a real EWB behavior with lesser errors. Besides, the Bell-Shaped curve is able to reduce the computational cost during simulation and also HILS testing. Previously, researchers derived mathematical equation using trigonometric function such as tangential function but the model is complicated since the method need to consider an asymptote point at the braking condition. Henceforth, the non-linear mathematical equation, Bell-Shaped curve, is developed as below

$$F_N = F_{rt} \left[1 / \left(1 + \left| \frac{x-c}{a} \right|^{2b} \right) \right] \quad (5)$$

where

F_N = maximum clamping force for EWB system

F_{rt} = real time clamping force of EWB system

x = piston displacement (input)

a and b = spread of the curve

c = center of the curve

The parameters a , b and c were identified and is used as the simulation model to replace the EWB actuator for simulation purpose. The parameters of a , b and c are estimated through Knowledge Based Tuning (KBT) method [21]. In this method, the qualitative model has been used as the search point for the Bell-Shaped curve parameters. Meanwhile, the accuracy of the Bell-Shaped curve parameters are evaluated by comparing with the actual EWB response after each iteration procedure.

These evaluations are used to improve the qualitative model in order to extract better estimation parameters which are more suitable for the Bell-Shaped curve. The parameters of the Bell-Shaped curve model are listed in Table 2. The proposed Bell-Shaped curve model is also known as the non-parametric model where the model is developed based actual input data from the EWB experimental as explained in section 3.0. The model was developed using actual brake force response without neglecting frictional force acting during clamping. Meanwhile, previous researchers developed an equation by neglecting most of external disturbance in order to simply the brake model.

Table 2 Simulation parameter for bell-shaped curve

Description	Value
F_{rt}	3500 N
$\mu_{friction}$	0.35
$r_{effective}$	0.15 m
a	6.295×10^{-4} m
b	2.820×10^{-4} m
c	9.570×10^{-4} m

The input of the proposed equation is the response obtained from LVDT sensor which is brake piston displacement meanwhile the output of this model represents the clamping force of EWB model. This equation can be divided into three main regions which are gapping mode, clamping mode and saturation mode as shown in the Figure 8.

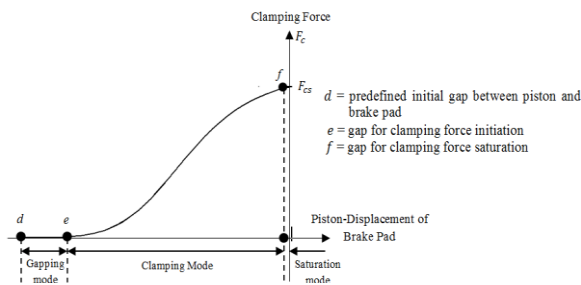

Figure 8 Nonlinear mathematical form of clamping force behaviour of EWB system

Once the input is given to the EWB model, the piston travels from its initial position and push the brake pad until it reaches a point where the clamping force of EWB starts. This section is known as the gapping mode of the EWB model. Clamping mode occurred when the clamping force is increased by decreasing the gap in between the brake pad and the starting point of brake disk from d to point f . The clamping force produced by the EWB system starts to saturate when the gap occur at point f approaches zero. Point f approaches zero gap condition (fully contact) when there are no changes occurred in the clamping zone. At this point, the EWB system approaches the saturation mode.

In order to calculate the brake torque, it is necessary to define the coefficient of friction between the disc and pad contact interface. Basically, the coefficient of friction, $\mu_{friction}$ is dependent on braking conditions such as disc speed, temperature and friction of the disc, brake line pressure and road conditions²². In this study, the coefficient of friction is obtained based on friction characteristic [23, 24]. Meanwhile, Figure 9 shows the contact interface of the clamping force and brake torque to the brake disc. The braking torque for EWB can be predicted [13] as

$$T_b = F_{friction} r_{effective} \tag{6}$$

where

$$F_{friction} = 2\mu_{friction} F_N \tag{7}$$

Then,

$$T_b = 2\mu_{friction} F_N r_{effective} \tag{8}$$

where

- T_b = brake torque produced
- $F_{friction}$ = friction force generated at the contact interface
- $r_{effective}$ = effective pad radius
- F_{normal} = normal force
- $\mu_{friction}$ = average friction coefficient on the surface

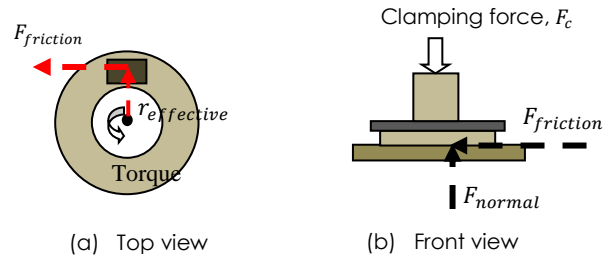

Figure 9 Brake torque model in contact interface [13]

5.0 EWB EXPERIMENT AND VALIDATION RESULTS

In this study, the EWB Model was simulated for 2.4 second. The model was simulated using Heun solver with a step size of 0.01 second. The parameters obtained from the experimental data are the gapping mode, clamping mode and the saturation mode. The response of the real EWB system obtained from the test bench is used as a benchmark to compare with the clamping force and brake torque responses of the simulation model. Figure 10 shows the rotational input at the worm pinion obtained using a potentiometer. Meanwhile, Figure 11 shows the linear displacement response of the brake piston measured using LVDT during the HIL experiment. The results obtained from the linear displacement are used as the input for the simulation model of EWB model.

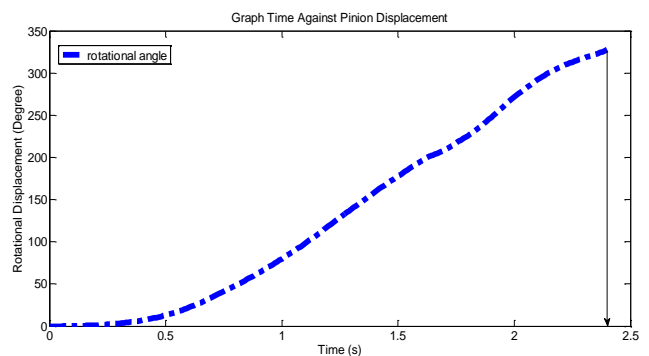

Figure 10 Rotational input using potentiometer

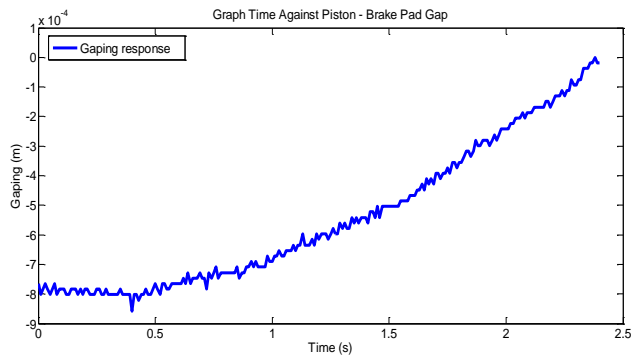

Figure 11 Displacement response using LVDT

Comparison of the clamping force between simulation and real EWB can be obtained based on the input given to the real EWB system and simulation model. The comparison of the response between real EWB system and simulation model is shown in Figures 12 and 13. The accuracy of the proposed model with the experimental results is compared using the root mean square error technique by measuring the percentage of errors between simulation and experimental results. Based on the root mean square error (RMSE) value for both clamping force and brake torque of the simulation model are up to 0.58 and 0.603 meanwhile the RMSE value for the EWB actuator in term of clamping force and brake torque are 0.561 and 0.596.

By measuring the percentage of errors for both clamping force and brake torque which are 3.3% and 1.2%, it can be concluded that the clamping force and brake torque produced by the simulation model is identical with that produced by the real EWB mechanism with RMSE value less than 10% errors. The model developed by previous researchers has achieved the percentages of errors up to 15% where the percentages are higher than the proposed model [9]. The response of the clamping force in Figure 12 is based on the force produced between the brake pad and brake disc during the experiment. The accuracy of the model depends on the selection of parameters such as gapping mode from the experimental data. Figure 13 shows the brake torque produced is similar in trend. The brake torque is obtained mathematically using a constant brake friction which was developed in previous research work [13].

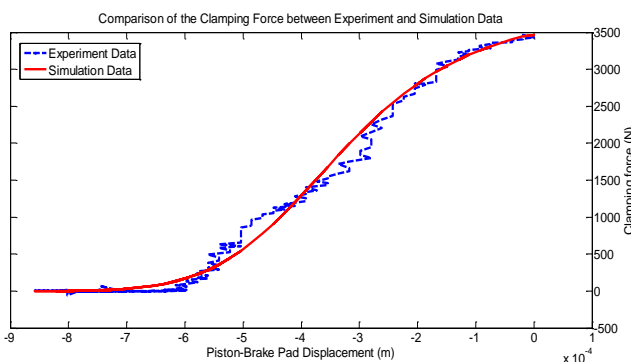

Figure 12 Comparison of the clamping force response between experiment and simulation data

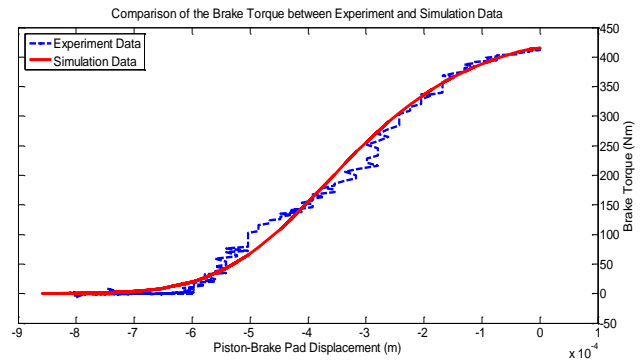

Figure 13 Comparison of the brake torque response between experiment and simulation data

Based on these results, the proposed EWB model produces clamping force and brake torque characteristic at the contact interface with good agreement with the real EWB system. The force produced by the real EWB system was measured using force sensor while the brake torque was obtained by calculation by converting clamping force to brake torque. It can be concluded that the proposed model of the EWB system is acceptable and can be used for control design of intelligent braking system such as Antilock Braking System (ABS), Electronic Brake Distribution (EBD) and Electronic Stability Program (ESP).

6.0 CONCLUSION

An EWB test rig has been developed to evaluate the behavior of an EWB actuator. The behavior of EWB has been evaluated using hardware-in-the-loop (HIL) experiment method using DC motor and 3 types of sensors. The clamping force characteristic of EWB based on three different regions known as gapping, clamping and saturation modes has been studied. The torque produced by the EWB can be estimated by combining the proposed force model with the torque model in contact interface. A non-linear mathematical model, Bell-Shaped curve was proposed to represent the characteristic of a real EWB actuator. The characteristic of both clamping force and brake torque using a non-linear mathematical equation, Bell-Shaped curve, was validated using HIL experiment data. This proposed model is proven simple, able to capture the behavior of EWB actuator and also can avoid the complexity during modelling. The results show that the behavior of the proposed model has good agreement with the behavior of the real EWB actuator. Hence, this model can be implemented in EWB mechanism if the mechanism is measured using linear displacement input and clamping force of EWB is measured as the output.

Acknowledgement

This work is supported by the Universiti Teknikal Malaysia Melaka, (UTeM) through a short term grant project entitled "Safety and Stability Enhancement of Automotive Vehicle Using ABS with Electronic Wedge Brake Mechanism" lead by Mr Fauzi Ahmad at the Technical University of Malaysia Malacca. This financial support is gratefully acknowledged.

References

- [1] Jeon, K., Hwang, H., Choi, S., Hwang, S., Choi, S. B., and Yi, K. 2012. Development of a Fail-safe Control Strategy Based on Evaluation Scenarios for an FCEV Electronic Brake System. *International Journal of Automotive Technology*. 13(7): 1067-1075.
- [2] Ho, L.M., Roberts, R., Hartmann, H., and Gombert, B. 2006. The Electronic Wedge Brake-EWB. *SAE Paper*. No. 2006-01-3196.
- [3] Ahn, J. K., Jung, K. H., Kim, D. H., Jin, H. B., Kim, H. S., and Hwang, S. H. 2009. Analysis of a Regenerative Braking System for Hybrid Electric Vehicles Using an Electro-mechanical Brake. *International Journal of Automotive Technology*. 10(2): 229-234.
- [4] Hoseinnezhad, R. and Bab-Hadiashar, A. 2008. Recent Patents on Measurement and Estimation in Brake-by-wire Technology. *Recent Patents on Electrical Engineering*. 2(1): 54-64.
- [5] Kim, J. G., Kim, M. J., Chun, J. H. and Huh, K. 2010. ABS/ESC/EPB Control of Electronic Wedge Brake. *SAE Paper*. No. 2010-01-0074.
- [6] Hwang, W., Han, K., and Huh, K. 2012. Fault Detection and Diagnosis of the Electromechanical Brake Based on Observer and Parity Space. *International Journal Automotive Technology*. 13(5): 845-851.
- [7] Semsey, A. and Roberts, R. 2006. Simulation in the Development of the Electronic Wedge Brake. *SAE Paper*. No. 2006-01-3196.
- [8] Ki, Y. H., Lee, K. J., Cheon, J. S., and Ahn, H. S. 2013. Design and Implementation of a New Clamping Force Estimator in Electro-Mechanical Brake Systems. *International Journal Automotive Technology*. 14(5): 739-745.
- [9] Hartmann, H., Schautt, M., Pascucci, A. and Gombert, B. 2002. eBrake-The Mechatronic Wedge Brake. *SAE Paper*. No. 2002-01-2582.
- [10] Plummer, A.R. 2006. Model-in-the-loop Testing. *Proceeding of Institute of Mechanical Engineering Part I: Journal Systems and Control Engineering*. 220(3): 183-199.
- [11] Roberts, R., Gombert, B., Hartmann, H., Lange, D. and Schautt, M. 2004. Testing the Mechatronic Wedge Brake. *SAE Paper*. No. 2004-01-2766.
- [12] Aparow, V. R., Ahmad, F., Hudha, K. and Jamaluddin, H. 2014. Model-in-the-loop Simulation of Gap and Torque Tracking Control Using Electronic Wedge Brake Actuator. *International Journal Vehicle Safety*. 7(3): 390-408.
- [13] Rahman, M.L.H. Abd., Hudha, K., Ahmad, F. and Jamaluddin, H. 2012. Design and Clamping Force Modelling of Electronic Wedge Brake System for Automotive Application. *International Journal of Vehicle Systems Modelling and Testing*. 8(2): 145-156.
- [14] Emam, M. A. A., Emam, A. S., El-Demerdash, S. M., Shaban, S. M. and Mahmoud, M. A. 2012. Performance of Automotive Self Reinforcement Brake System. *Journal of Mechanical Engineering*, 1(1): 4-10.
- [15] Han, K., Kim, M., and Huh, K. 2012. Modeling and Control of an Electronic Wedge Brake. *Proceedings of the Institution of Mechanical Engineers, Part C: Journal of Mechanical Engineering Science*. 226(10): 2440-2455.
- [16] Mamilla, V. R. and Mallikarjun, M. V. 2009. Control of Electro-Mechanical Brake with Electronic Control Unit. *International Journal of Electronic Engineering Research*. 1(3): 195-200.
- [17] Li, W. G., Mo, M. S., Liu, Q. Q., and Deng, R. Y. 2009. Design of Hill Start Auxiliary System Controller Based on ATmega32. *Journal of Machinery and Electronics*. 10: 008.
- [18] Ping, E. P., Hudha, K., and Jamaluddin, H. 2010. Automatic Steering Control for Lanekeeping Maneuver: Outer-Loop and Inner-Loop Control Design. *International Journal of Advanced Mechatronic Systems*. 2(5/6): 350-368.
- [19] Mehta, S. and Chiasson, J. 1998. Nonlinear control of a series DC motor: theory and experiment. *In IEEE Transactions on Industrial Electronics*. 45.
- [20] Calvo-Rolle, J. L., Garcia, R. F., Casanova, A. C., Quinti n-Pardo, H. and Alaiz-Moreton, H. 2011. Conceptual Model Development for a Knowledge Base of PID Controllers Tuning in Open Loop. *Expert Systems for Human, Materials and Automation*. ISBN: 978-953-307-334-7. 239-258. In Tech.
- [21] Aparow, V. R., Ahmad, F., Hudha, K. and Jamaluddin, H. 2013. Modeling and PID Control of Antilock Braking System with Wheel Slip Reduction to Improve Braking Performance. *International Journal Vehicle Safety*. 6(3): 265-296.
- [22] Han, K., Huh, K., Hwang, W., Kim, M. and Kim, D. 2012. EWB Control Based on the Estimated Clamping Force. *SAE Paper*. No. 2012-01-1797.
- [23] Jo, C. H., Lee, S. M., Song, H. L., Cho, Y. S., Kim, I., Hyun, D. Y., and Kim, H. S. 2010. Design and Control of an Upper-wedge-type Electronic Brake. *Proceedings of the Institution of Mechanical Engineers, Part D: Journal of Automobile Engineering*. 224(11): 1393-1405.