

INFLUENCE OF RECTANGULAR STEEL SPICE-SLEEVE FOR PRECAST CONCRETE CONNECTION

Ahmad Baharuddin Abd Rahman*, Tan Kee Hong, Izni Syahrizal Ibrahim, Rosli Noor Mohamed

Department of Structures and Materials, Faculty of Civil Engineering, Universiti Teknologi Malaysia, 81310 UTM Johor Bahru, Johor, Malaysia

Article history

Received

15 April 2015

Received in revised form

29 September 2015

Accepted

12 November 2015

*Corresponding author
baharfka@utm.my

Graphical abstract

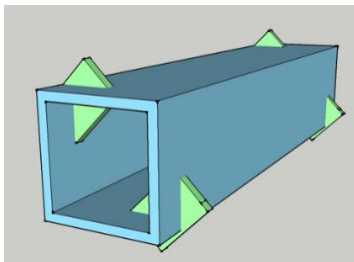

Rectangular Steel Splice-Sleeve

Abstract

Precast concrete building system has gained its popularity in Malaysia because of the many advantages such as high quality of structural components, less labour intensive at the construction site, and shorter completion time of a project. One of the constraints in precast concrete structures is to ensure that the connections are strong enough to ensure the structural integrity and robustness of the overall frames. In this study, a total of nine rectangular steel splice-sleeve connections were tested experimentally under incremental tensile loads. Two steel plates were inserted and welded to each end of the steel splice-sleeve. The steel plates act as shear key to provide the interlocking mechanism to the grout and to enhance the bond property between the grout and the splice. These plates were adopted to prevent the grout slippage from the sleeve. The grout strength, embedded steel bar lengths and the size of the steel sleeve splice were varied among the specimens to study their effect on the tensile performance of the connection. The results showed that the higher strength of grout, longer embedded length of steel bar and smaller size of the sleeve contributes to a higher ultimate tensile load.

Keywords: Grouted splice connection, bond stress, confinement, tensile tests, precast concrete connection

© 2015 Penerbit UTM Press. All rights reserved

1.0 INTRODUCTION

Precast concrete building system is one of the popular Industrialised Building Systems (IBS) in Malaysia, see Figure 1. In the precast concrete IBS system, precast concrete components such precast concrete walls, beams and columns are fabricated using steel moulds in factories. These pre-fabricated precast concrete components are then delivered to construction site for erection and installation. To facilitate the process of installation, structural connections are required to join the loose precast concrete components together.

Basically, precast concrete components are joined together by making a connection between extruded steel bars from the lower and upper panels, see Figure 2. To join these extruded steel bars, several methods

can be used such as welding, grouting or bolting. However, grouting is one of the popular method and it requires sleeve to allow grout to be filled-in to join the steel reinforcement bars.

Regardless of the method in jointing the reinforcement bars, the connections must have the ability to provide the strength and the structural integrity of the connected precast concrete components.

The precast structural members can also be connected by the lapping of reinforcement steel bars. However, the lapping normally requires long lapped reinforcement bars especially with the larger bar diameter thus leading to congestion of reinforcement bar in concrete members [1], [2], [3], [4].



Figure 1 Precast concrete buildings constructed using precast concrete wall components

Extruded steel bars

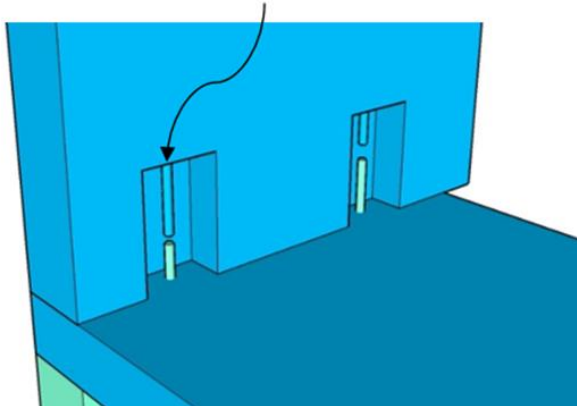

Figure 2 Connections between steel reinforcement bars from the lower and upper panels

As an alternative to lapping method, grouted steel sleeve splices can be used as a connection system to join the reinforcement bars provided in the structural components to ensure continuity between the connected precast concrete members [2], [4].

In a grouted sleeve connection, steel bars are inserted into the sleeve body from both ends, meeting at its mid length, before grouting material is in-filled. Ideally, the spliced steel reinforcement bars should behave as a continuous bar, especially in tensile resistance. The sleeve zone should be strong and should generate bond strength that is greater than the tensile capacity of its reinforcement bars, thus, preventing the slippage of connected reinforcement bars out of the sleeve [4], [5], [6].

A grout-filled splice-sleeve was invented by Alfred A. Yee in the late 1960 in Hawaii [7], [8]. The connection was introduced in Japan by Nisson Master Builders (NMB) and then given the connector's name as NMB Splice-Sleeve® system. The splice sleeves were first used in precast concrete column-tree connections for 38 stories Ala Moana Hotel, Honolulu, Hawaii. The NMB

Splice Sleeve uses cylindrical shaped cast iron filled with special premix Portland cement based non-shrink grout with brand name Splice Sleeve (SS) Mortar.

In 1981, sleeve technique was widely used in construction of a 5-story residential projects under Housing and Urban Development Board (HUD) of Japan. Soon after in 1990s, its applications in high-rise building over 30 stories were very common. These includes 30-story residence tower, Shin Kawasaki, 37-story Ohkawabata high-rise residence (1989), 30-story Las Vegas MGM Grand Hotel in 1991, 39-story Paramount tower in San Francisco in 1999, and 56-story Shiodome H residential tower in Tokyo in 2002.

Recently, in 2014, Eliya Henin and George Morcouc [9] conducted experimental tests on non-proprietary bar splice sleeve for precast concrete construction. The proposed grouted splice connection uses a circular steel pipe that has more flexible tolerance, economical and easy to produce.

All the splice connections rely primarily on the grout strength and confinement to improve bond strength, thus resulting in a short development length of the spliced bars within the grout-filled hardware [2].

The variables that may affect the bond strength of reinforcing bars confined with steel pipe include the yield strength of the reinforcing bar, the grout strength, the properties of the pipe, and the geometry of the bar and its confining region. Geometrical variables include the bar diameter and its embedment length into the confined grout, the inside diameter of the pipe, the pipe's wall thickness, and the geometry of the pipe's free ends [5].

Hayashi *et al.* [10] found a relationship between the maximum local bond stress and the slip of a bar in a grout-filled deformed steel sleeve. Their results indicate that the bond stress increases linearly with grout strength at the non-yielded portion of the bars while it is constant at the yielded portion of the bars regardless of the grout strength [11].

Adajar *et al.* [11] performed an experimental bar splicing investigation using a combination of lapping bars and confining spirals. They concluded that the ultimate strength of the splices used is equal to the tensile strength of the spliced bar when the lapping distance equals or exceeds 25 times the bar diameter [13].

Amin Einea *et al.* [2] performed an experimental bar splicing to evaluate the bond strength of reinforcing bars as a function of grout compressive strength and the level of confinement. They concluded lap splice or embedment lengths as short as seven times the bar diameter can achieve bar development when the appropriate grout compressive strength and confinement are provided. In fact, with grout-filled butt pipe splices, a high splicing strength can be obtained by welding steel rings on the inside of the pipe at both ends [2].

Most of the research works on grouted splices involved the use of circular steel pipe. This paper, however, proposes a non-proprietary grouted sleeve using rectangular steel section.

This paper presents the parametric studies on nine proposed mild steel splice-sleeve using generic rectangular steel section to splice Y16 high yield steel main bars. All the specimens were tested under incremental tensile load until failure to obtain their tensile capacities [5], [6], [9], [12].

The objectives of the research are to investigate the effects of grout strength, main bar embedment length and sleeve size in influencing the behavior and performance of the rectangular splice connection.

2.0 EXPERIMENTAL PROGRAMME

2.1 Descriptions of Test Specimens

The test specimens represented grouted splice sleeve connections for connecting two main reinforcement bars. A good connection should have the ability to ensure the connected main bars fracture outside the sleeve when it is subjected to tensile load.

In this study, nine specimens were prepared for the lab testing. Each specimen, see Figure 3(a), consisted of a rectangular steel hollow section made from mild steel acted as the sleeve. This sleeve is also referred as splice. The rectangular steel section had 2 steel plates inserted and welded at 25 mm from both sleeve ends. The steel plates acted as a shear key to provide interlocking mechanism to enhance the bond property between the grout and the sleeve. The main

steel bars to be connected consisted of two high yield deformed bars in 16 mm diameter (Y16) and 600 mm long reinforcement steel bars.

The nine specimens were divided into 3 groups in order to investigate 3 different parameters in influencing the tensile performance of the splice connections. The 3 parameters involved, see Table 1(a), 1(b) and 1(c), were grout strength (at 1-day, 6-day and 9-day), embedded length of steel reinforcement bar (55 mm, 90 mm and 125 mm) and the size of rectangular steel sleeve as the splice (50 × 50 mm, 65 × 65 mm and 75 × 75 mm). For the control specimen, Y16 steel bar was subjected to the tensile loading. Figure 3(b) shows the details of the specimens.

Einea *et al.* [2] proposed an embedment length as short as 7 times the bar diameter to achieve bar development when the appropriate grout compressive strength and confinement are provided. In this study an embedment length of 55 mm (3.5 times bar diameter), 90 mm (5.6 times bar diameter) and 125 mm (7.8 times bar diameter) were selected as the embedment length of the rebars. In the case of grout strength, Eina *et al.* [2] conducted the tests on grouted splice using grout compressive strength of 45, 55 and 68.9 MPa.

In this study, grout strength of 21.9, 55.3 and 61.2 N/mm² were adopted to study the influence of grout strength the tensile performance of the connection.

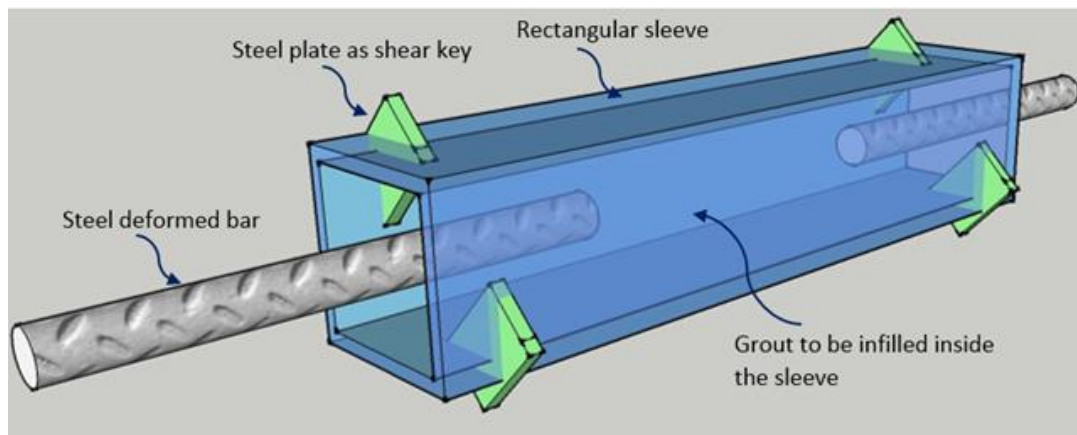

(a) Parts of sleeve connection

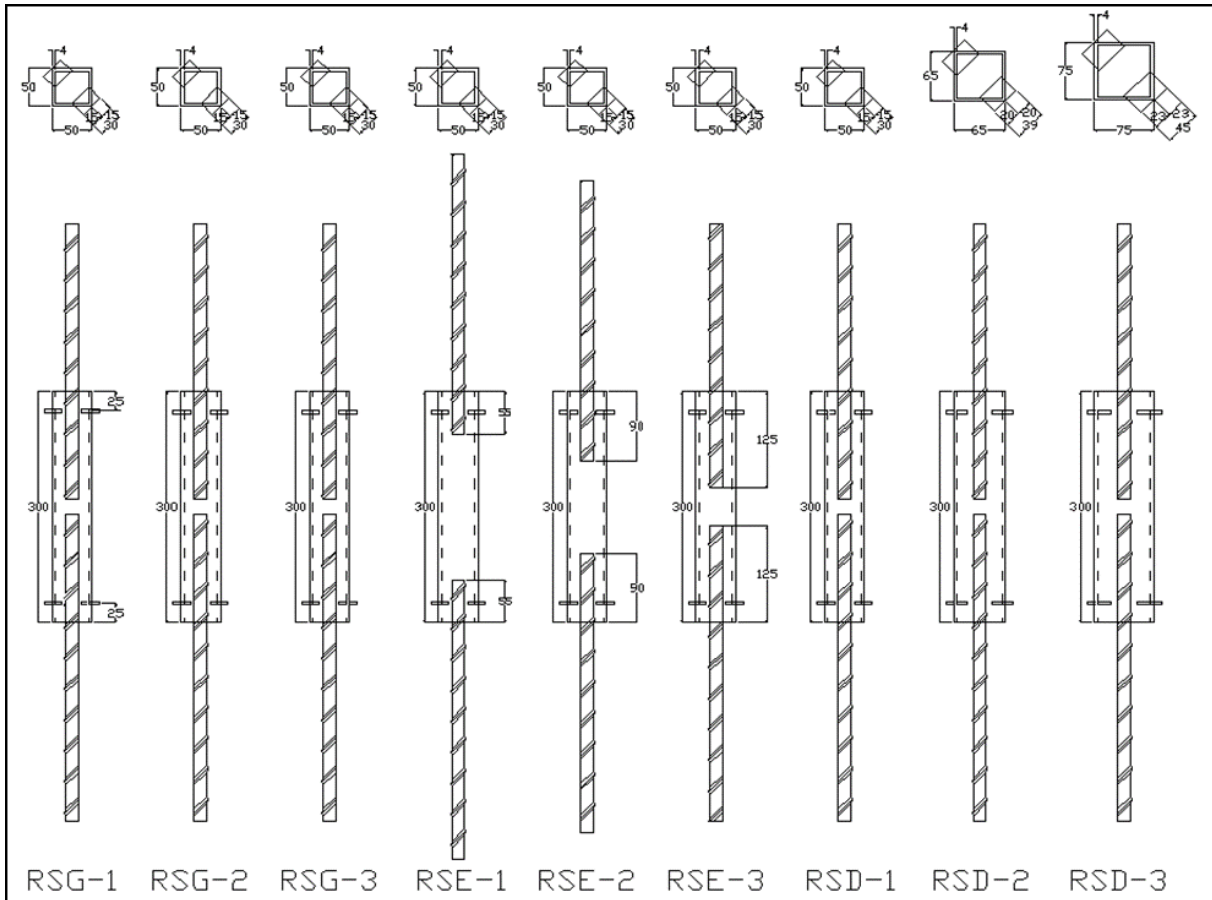

(b) Rectangular sleeve connections with different configurations
Figure 3 Details of the specimens

Table 1(a) Sleeve for RSG group, different grout strength

Specimen	Testing day	Grout strength (N/mm ²)
RSG-1	1-day	21.9
RSG-2	6-day	55.3
RSG-3	9-day	61.2

Embedment length of rebars = 140 mm for specimens RSG-1, RSG-2 and RSG-3



Table 1(b) Sleeve for RSE group, different bar embedment length

Specimen	Embedded steel bar length (mm)
RSE-1	55
RSE-2	90
RSE-3	125

Steel sleeve size = 50 mm x 50 mm for specimens RSG-1, RSG-2 and RSG-3



Table 1(c) Sleeve for RSD group, different sleeve sizes

Specimen	Size (mm)
RSD-1	75 × 75
RSD-2	65 × 65
RSD-3	50 × 50

Embedment length of rebars = 140 mm for specimens RSD-1, RSD-2 and RSD-3

Different sizes of RSD-1, RSD-2 and RSD-3

The splice specimens were then divided into 3 groups for testing. The first group, involving specimen RSG-1 only, was tested on the first day. The grout strength on that day was 21.90 N/mm².

The second group, consisting of specimen RSG-2 only, was tested on the sixth day. The grout strength on that day was 55.34 N/mm².

The last group was tested on the ninth day and the grout strength was 61.24 N/mm². The specimens tested on that day were RSG-3, RSE-1, RSE-2, RSE-3, RSD-1, RSD-2 and RSD-3.



Figure 5 Pouring of Grout into Sleeves

2.2 Preparation of Test Specimens

Wooden frames were prepared to hold the specimens before the grout were poured into the sleeves, see Figures 4 and 5. The specimens were arranged vertically. The steel bars to be inserted into the sleeve were measured first and aligned along the central axis of the steel sleeve. After all the specimens were prepared, Sika-215 Grout was mixed into pourable state and poured into each sleeve to fill the volume inside the sleeve. SikaGrout-215 was mixed based on the specifications specified by the manufacturer. For each 25 kg of cement grout, it requires 4 liters of clean water in order to achieve the pourable consistency of wet grout. Figure 4 shows the grout preparation.



Figure 4 Preparation of grout

All the specimens were tested under incremental tensile load until failure, see Figure 6. Each specimen was loaded in tension using a hydraulic actuator. Each end of the steel bar was gripped by the actuator arm. The rate of increasing tensile load was 0.5 kN/sec. The data of load against displacement were recorded during the test.

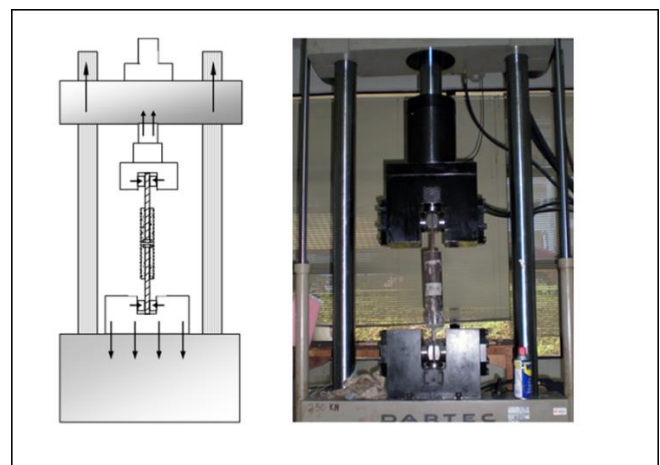

Figure 6 Tensile test of the grouted specimen

3.0 RESULTS AND DISCUSSION

3.1 Ultimate Load Capacity and Failure Mode

Table 2 summarizes the tensile performance of the connection specimens in terms of ultimate tensile capacity, P (kN), the corresponding displacement at

ultimate state, Δ (mm), and its failure modes. A good splice connection should be able to generate bond strength that exceeds the tensile resistance of the connected steel bars. Therefore in this table, the ultimate loads of the tested specimens are compared against the capacity required by the BS 8110 [4] and ACI 318 [3] codes.

Table 2 Tensile Performance of Specimens

Specimen	Max tensile capacity P (kN)	Max displacement Δ (mm)	BS 8110, $P_{BS} = 0.95f_yA_s$ (kN)	ACI, $P_{ACI} = 1.25f_yA_s$ (kN)	P/P_{BS}	P/P_{ACI}	Failure mode
Steel bar	111.3	62.7	95.5	103.0	1.17	1.08	Bar fracture
RSG-1	21.9	8.9	95.5	103.0	0.23	0.21	Bar slippage
RSG-2	55.3	7.2	95.5	103.0	0.58	0.54	Bar slippage
RSG-3	61.2	27.2	95.5	103.0	0.64	0.59	Bar slippage
RSE-1	14.1	2.2	95.5	103.0	0.15	0.14	Bar slippage
RSE-2	60.8	21.6	95.5	103.0	0.64	0.59	Bar slippage
RSE-3	69.1	8.3	95.5	103.0	0.72	0.67	Bar slippage
RSD-1	72.8	25.7	95.5	103.0	0.76	0.71	Bar slippage
RSD-2	79.9	8.8	95.5	103.0	0.84	0.78	Bar slippage
RSD-3	94.6	19.6	95.5	103.0	0.99	0.92	Bar slippage

The ultimate tensile capacity of the Y16 control specimens was 111.3 kN. According to ACI 318 clause 12.14.3.2, a full working splice should be able to develop at least 125% of the specified yield strength of steel bar which is 103.0 kN. From the test results, none of the nine specimens were able to achieve both the ultimate tensile capacities of the control specimen (111.3 kN) or the value specified by the ACI 318 (103.0 kN).

On the other hand, according to BS 8110, clause 2.4.2.2 [4], the design strength is defined as the characteristic strength divided by γ_m , where γ_m is the appropriate partial safety factor which takes into account the differences between the actual and laboratory values, local weaknesses and inaccuracies in assessment of the resistance. Based on this requirement, the design strength is 95.5 kN. This value is used to determine whether the spliced steel bar managed to achieve the design strength.

Referring to Table 1 and Figure 6, all the specimens experienced bond failure between the steel bar and grout. This showed that the 2 steel plates welded into both ends that acted as shear key was not adequate to provide a good interlocking mechanism between the grout and the splice.

Figure 7(a) shows pullout failure between main reinforcement bar and the surrounding grout. This failure occurred due to loss of bond as a result of inadequate shear resistance between the ribbed bars and the grout. Figure 7(b) shows the pullout failure between the grout and the steel sleeve. This failure occurred due to lack of resistance provided by the steel plate shear keys. Hence, the shear key provided by the steel plate can be improved further by adding

short horizontal reinforcement bars at each end of the sleeve splice.



(a) Bar and grout failure



(b) Grout and sleeve failure

Figure 7 Bond slippage failure

3.2 Load Transfer and Bond Mechanism

Figure 8 shows the load transfer mechanism between the grout and the steel sleeve. The steel plates welded into the steel sleeve act as shear key to prevent the grout from pulling out from the steel sleeve. The steel plates provide an effective shear area to resist the tensile force. This load transfer mechanism enables the tensile stress to be transferred to the steel sleeve.

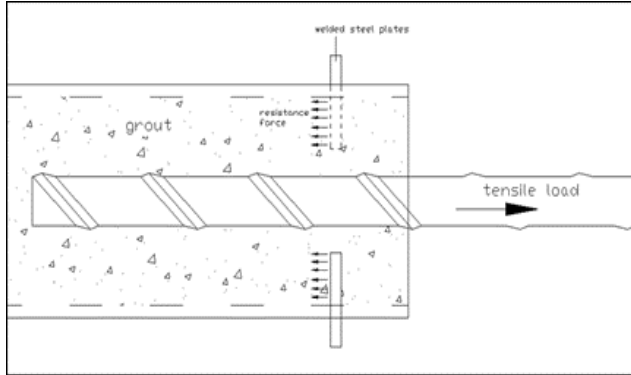

Figure 8 Load transfer mechanism between grout and sleeve

Figure 9 shows the load resisting mechanism between the steel bar and the grout. The deformed steel bars consist of many ribs. As the tensile load is applied, the steel bar is pulled out from the sleeve. The ribs around the steel induce anchorage bond in terms of bearing interlocking in the grout to resist the tensile load and subsequently prevent the steel bar from being pulled out from the sleeve.

The bond performance between the steel bars and the grout relies significantly on the interlocking forces between the ribs and the grout bearing [13], [14], [15].

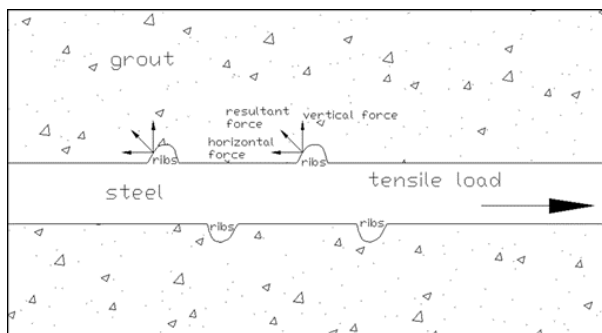

Figure 9 Load transfer mechanism between steel bar and grout

3.3 Effect of Grout Strength

Figure 10 shows the load-displacement response of the splice connections with different grout strength. The grout strength for specimens RSG-1, RSG-2 and RSG-3 were 21.90 N/mm², 55.34 N/mm² and 61.24 N/mm² respectively. All the 3 specimens have similar sleeve size of 50 × 50 mm and embedded rebar length of 140 mm.

It was observed that an increase in grout strength increases the tensile performance of the splice connection. This is in-line with the findings by Eina *et al.* [2]. However, the difference of ultimate tensile load between specimens RSG-2 with compressive strength of 55.34 N/mm² and RSG-3 with compressive strength of 61.24 N/mm² was 4.2 kN, i.e. about 5% increase. This showed that when the grout strength values were in the range of 55 N/mm² to 65 N/mm², only a small increase in the tensile load performance was observed. In brief, once the grout compressive strength exceeded 55 N/mm², then any increment in grout compressive strength did not increase much the tensile load.

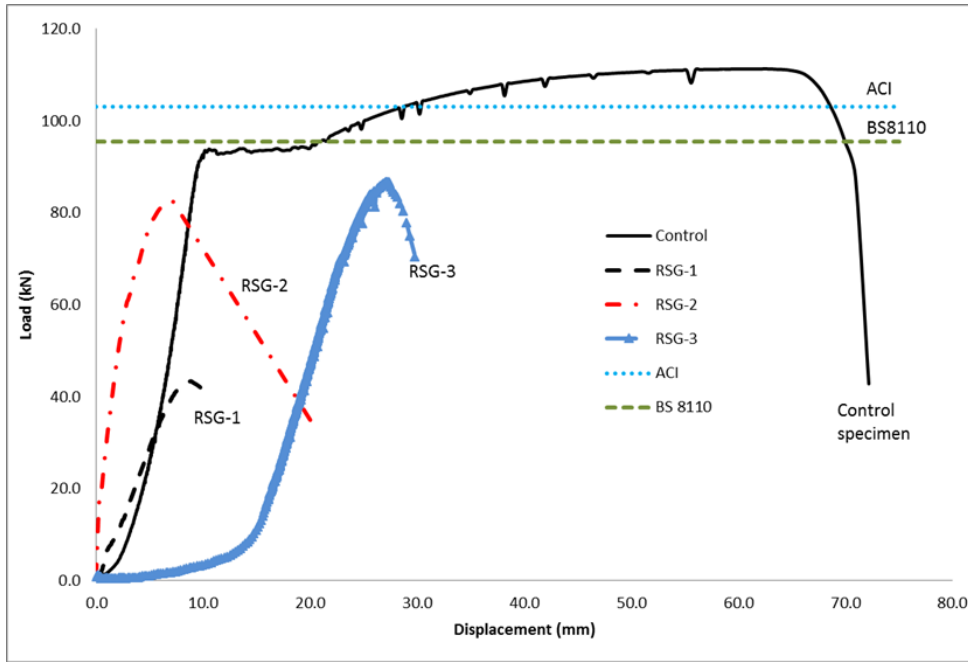

Figure 10 Effect of grout strength

3.4 Effect of Main Bar Embedment Length

Figure 11 shows the load-displacement response of the splice connections with different main bar embedment lengths. All the 3 specimens had similar sleeve size of 50 × 50 mm and grout strength of 61.24

N/mm². The figure shows that the longer the embedded length, the larger the ultimate tensile capacity of the sleeve connection.

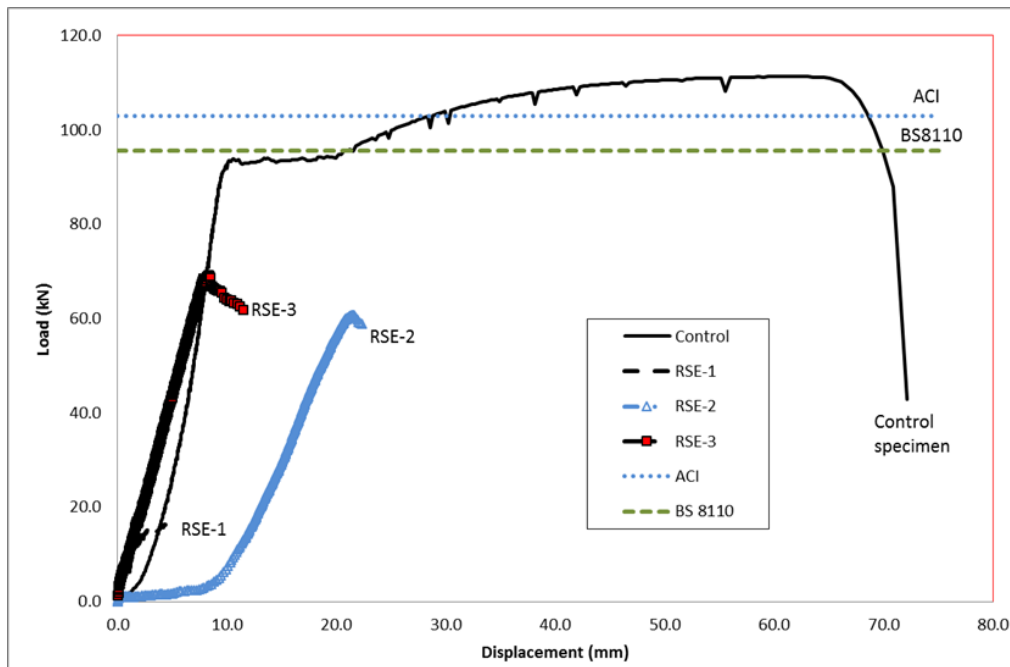

Figure 11 Effect of main bar embedment length

3.5 Effect of Sleeve Size

Figure 12 shows the load-displacement response of the splice connections with different sizes of sleeve. All the specimens had similar grout strength of 61.24 N/mm² and similar embedded steel bar length of 140 mm.

The results show that, the smaller the size of the steel sleeve, the larger is the ultimate tensile strength. The smaller sleeve has the larger confinement effects which effectively confined the connected main steel bars. This confinement increases the bond strength and delayed the bar slippage, subsequently increases the bond strength.

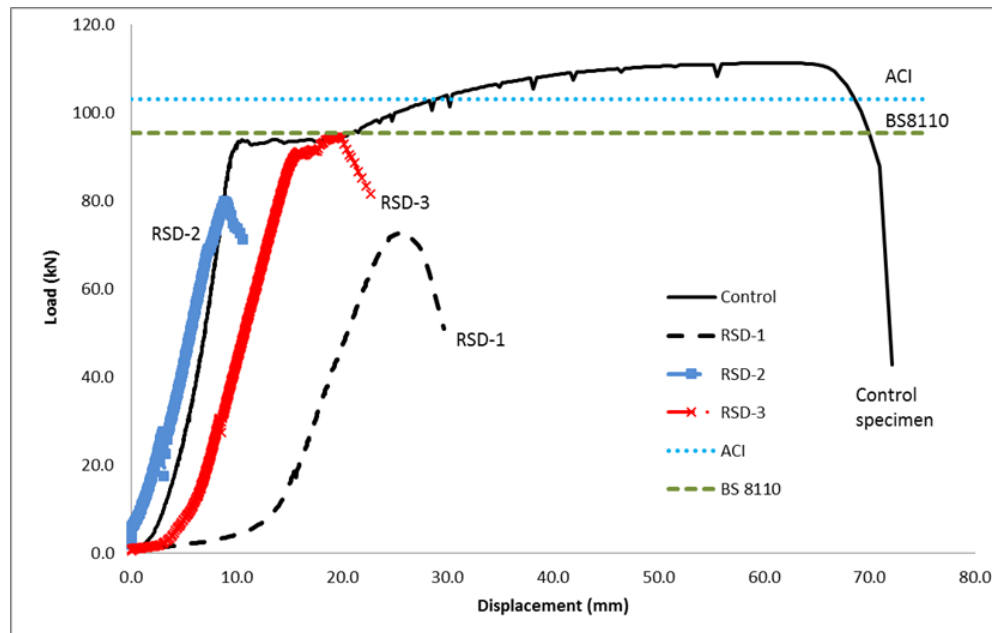

Figure 12 Effect of sleeve size

4.0 CONCLUSION

The conclusions that can be drawn from this study are as follows:

1. The compressive strength of the grout plays an important role in improving the connection performance. The higher the compressive strength of the grout the larger is the failure load of the connection.
2. The embedded length of the connected steel bars has significant effect to the tensile performance of the splice sleeve. The larger the embedment length the larger is the tensile performance of the connection. It is suggested that the embedment length of 200 mm may be adequate for connected reinforcement bars anchored in the rectangular splice to achieve full tensile strength [5].
3. The size of the rectangular splice also significant to the performance of the connection. The smaller sleeve provides larger failure load due to confinement effect in the steel section that increases the bond strength between steel bars and grout.

Acknowledgement

The authors would like to thank the Universiti Teknologi Malaysia (UTM) and Ministry of Higher Education (MOHE) – Vot 06H61, in providing the grant for conducting this experimental study.

References

- [1] James R. C. and R. Apple. 2005. Economic Analysis, Mechanical Butt Splice Vs Lap Splicing In Reinforced Concrete Construction. Ohio: ERICO® Inc.
- [2] Einea, A., T. Yamane, and M. K. Tadros. 1995. Grout-filled Pipe Splices for Precast Concrete Construction. *PCI Journal*. January-February: 82-93.
- [3] ACI 318-02 and Commentary ACI 318 R-02. 2002. *Building Code Requirement for Structural Concrete*. Farmington Hills: American Concrete Institute.
- [4] BS 8110-1. 1997. *Structural Use of Concrete, Part 1: Code of Practice for Design and Construction*. London: British Standard Institution.
- [5] Ling, J. H., A. B. Abd Rahman, I. S. Ibrahim, and Z. Abdul Hamid. 2012. Behaviour of Grouted Pipe Splice under Incremental Tensile Load. *Construction and Building Materials*. 33: 90-98.
- [6] Hosseini, S. J. A. and A. B. Abd Rahman. 2013. Analysis of Spiral Reinforcement in Grouted Pipe Splice Connectors. *GRAĐEVINAR*. 65(6): 1-10.

- [7] Alfred, A. Y. 1986. Splice Sleeve for Reinforcing Bars with Cylindrical Shell. U.S. Patent No. 4,627,212.
- [8] Alfred A. Y. 1970. Splice Sleeve for Reinforcing Bars. U.S. Patent No. 3540763A.
- [9] Eliya, H. and G. Morcous. 2015. Non-proprietary Bar Splice Sleeve for Precast Concrete Construction. *Engineering Structure*. 83: 154-162.
- [10] Hayashi, Y., R. Shimizu, T. Nakatsuka, and K. Suzuki. 1993. Bond Stress-Slip Characteristic of Reinforcing Bar in Grout-Filled Coupling Steel Sleeve. *Proceedings*. Japan Concrete Institute. 15(2): 265-270.
- [11] Adajar, J., T. Yamaguchi, and H. Imai. 1993. An Experimental Study on the Tensile Capacity of Vertical Bar Joints in a Precast Shear Wall. *Proceedings*. Japan Concrete Institute. 15(2): 1255-1261.
- [12] Ali A. S., A. B. Abd Rahman, M. Z. Jumaat, U. J. Alengaram and S. Ahmad. 2014. The Relationship between Interlocking Mechanism and Bond Strength in Elastic and Inelastic Segment of Splice Sleeve. *Construction and Building Materials*. 55: 227-237.
- [13] Rehm. 1961. *The Basic Principles of the Bond between Steel and Concrete*. London: Cement and Concrete Association. A translation from *Ueber die Grundlagen des Verbundes zwischen Stahl und Beton*, Deutscher Ausschuss für Stahlbeton. Berlin: Wilhelm Ernst & Sohn.
- [14] Alavi-Fard, M. and H. Marzouk. 2004. Bond of High-Strength Concrete under Monotonic Pullout Loading. *Magazine of Concrete Research*. 56(9): 545-557.
- [15] ACI Committee 408. 2003. *Bond and Development of Straight Reinforcing Bars in Tension*. Farmington Hills: American Concrete Institute.