

Identification and Model Predictive Position Control of Two Wheeled Inverted Pendulum Mobile Robot

Amir A. Bature^a, Salinda Buyamin^{a*}, Mohamad N. Ahmad^a, Mustapha Muhammad^b, Auwalu A. Muhammad^b

^aFaculty of Electrical Engineering, Universiti Teknologi Malaysia, 81310 UTM Johor Bahru, Johor, Malaysia

^bDepartment of Electrical Engineering, Bayero University Kano, Nigeria

*Corresponding author: salinda@fke.utm.my

Article history

Received : 15 August 2014
Received in revised form :
5 January 2015
Accepted : 10 February 2015

Graphical abstract

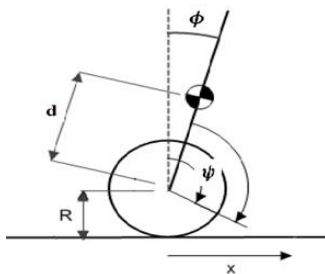

Abstract

In order to predict and analyse the behaviour of a real system, a simulated model is needed. The more accurate the model the better the response is when dealing with the real plant. This paper presents a model predictive position control of a Two Wheeled Inverted Pendulum robot. The model was developed by system identification using a grey box technique. Simulation results show superior performance of the gains computed using the grey box model as compared to common linearized mathematical model.

Keywords: Two Wheeled Inverted Pendulum (TWIP); Grey box model; Model Predictive Control (MPC)

© 2015 Penerbit UTM Press. All rights reserved.

1.0 INTRODUCTION

An accurate model of a robot is needed for controllers design purposes. Basically in developing a model, three techniques are used, white box modelling, black box modelling and grey box modelling technique [1]. The White-box model is based on the first principles of physics; usually derived from the Newton equations or Euler Lagrange methods. While the Black-box models are based on the measurement of input and output data. To develop a black box model, no or very little prior knowledge of plant is needed. In addition, the model parameters have no direct relationship to first principles. The third ways of developing a model of a plant is a Grey-box technique. It is a combination between white and black box models. The model and structure of this type are known, only the values of the parameters are estimated [1]. Models derived by grey box model tends to be more accurate than black box model.

In the past, many researches worked in the area of modelling and control of the robot [2-9]. Euler Lagrange method of modelling is shown in [2-4, 9], while Kane's method is done in [5, 10]. Newton's method is implemented in [6, 7, 11]. Takagi-Sugeno fuzzy modelling approach is done in [8]. System identification of the robot was illustrated in [12, 13]. In all mathematical modelling, that is white box modelling technique, approximation and

assumptions tends to make the model less accurate. Hence system identification approach, that is black and grey box model, is more accurate in describing the robot.

Also, in the control of TWIP, linear controllers were implemented. In [10], pole placement controller was applied at different linearized points and was used for velocity tracking, the controller tracks the desired velocity. A Linear Quadratic Regulator (LQR) was compared with partial feedback linearization for speed control in [14], and the nonlinear controller performs better than the linear controller. Nonlinear controllers were also investigated by researchers. In [9], partial feedback linearization was demonstrated, also Sliding Mode Control (SMC) method using LQR technique, was used to control the robot behaviour while driving on uniform slopes in [15]. Intelligent controllers were also used in controlling the TWIP. Fuzzy logic controllers (FLC) were investigated in [16, 17] to track desired speed and position. Adaptive intelligent controller were shown in [18, 19]. Model predictive controller (MPC) was used to control TWIP robot, as illustrated in [11] based on linearized model. MPC is a model base controller, the more accurate the model presents the actual system, the better the controller design becomes successful. MPC has the advantage of specifying constraints in the design, it is also an optimal controller [20].

Therefore, in this work, the MPC will be designed for position tracking of the TWIP robot. Two models will be used for the MPC design. Linearized model of the robot derived using white box and the other derived via grey box method of identification to show the superiority of grey box model over linearized model. The rest of the paper is organized as follows; section 2 describe the mathematical description of the robot and the grey box modelling of the robot, section 3 is the MPC controller design, section 4 is for the result and discussion, while section 5 gives the conclusion.

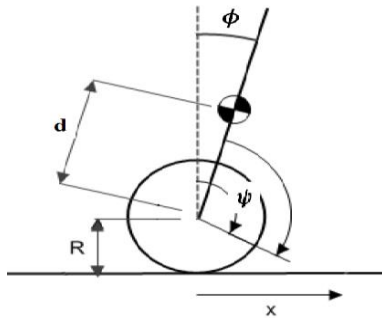

Figure 1 Free body diagram of the TWIP

2.0 DESCRIPTION OF THE TWIP MOBILE ROBOT MODEL

The mathematical model and the identified model of the TWIP is presented in this section.

2.1 Model of the TWIP

The dynamic equations of the TWIP mobile robot are presented in this section. Euler Lagrange method is used to derive the dynamic model as in [4]. Figure 1 shows the free body diagram of the robot. The three direction of movement of the robot are x transitional motion, φ tilt angle, and ψ yaw angle. The dynamic equations describing the robot are given below as in [4].

$$\ddot{\psi} = \frac{L}{R \left[2 \left(M_w + \frac{I_a}{R^2} \right) L^2 + I_y \sin^2 \phi + I_z \cos^2 \phi + M_b d^2 \sin \phi \right]} (\tau_1 - \tau_2) - \frac{2 [M_b d^2 + I_y - I_z] \sin \phi \cos \phi \dot{\psi} \dot{\phi}}{\left[2 \left(M_w + \frac{I_a}{R^2} \right) L^2 + I_y \sin^2 \phi + I_z \cos^2 \phi + M_b d^2 \sin \phi \right]} \dot{\phi}$$

$$\ddot{\phi} = \frac{(M_b R^2 + 2M_w R^2 + 2I_a) M_b g d}{[(M_b + 2M_w) R^2 + 2I_a] I_x + 2M_b d^2 (M_w R^2 + I_a)} \phi - \frac{(M_b R^2 + 2M_w R^2 + 2I_a) + M_b d R}{[(M_b + 2M_w) R^2 + 2I_a] I_x + 2M_b d^2 (M_w R^2 + I_a)} (\tau_1 + \tau_2)$$

$$\ddot{x} = - \frac{M_b^2 d^2 g R^2}{(M_b d^2 + I_x)(M_b R^2 + 2M_w R^2 + 2I_a) - (M_b d R)^2} \phi + \frac{R(M_b d^2 + I_x + M_b d R)}{(M_b d^2 + I_x)(M_b R^2 + 2M_w R^2 + 2I_a) - (M_b d R)^2} (\tau_1 + \tau_2)$$

The model is nonlinear, to linearize the model, we assume the operating point to be where the tilt angle φ = 0. Hence sinφ = φ, cosφ = 1, ψ̇ = 0, φ̇ = 0. Applying the assumption and substituting the parameters values in [4], the linearized equations becomes;

$$\ddot{\phi} = 68.9659\phi - 4.3006(\tau_1 + \tau_2) \quad (1)$$

$$\ddot{x} = -3.7706\phi + 0.4902(\tau_1 + \tau_2) \quad (2)$$

$$\ddot{\psi} = 1.0812(\tau_1 - \tau_2) \quad (3)$$

In state space form, the linearized equation is given in Equation 4.

$$A_l = \begin{bmatrix} 0 & 1 & 0 & 0 \\ 0 & 0 & -3.7706 & 0 \\ 0 & 0 & 0 & 1 \\ 0 & 0 & 68.9659 & 0 \end{bmatrix}, B_l = \begin{bmatrix} 0 \\ 0.599 \\ 0 \\ -5.776 \end{bmatrix}, C_l = \begin{bmatrix} 1 & 0 & 0 & 0 \\ 0 & 0 & 1 & 0 \end{bmatrix} \quad (4)$$

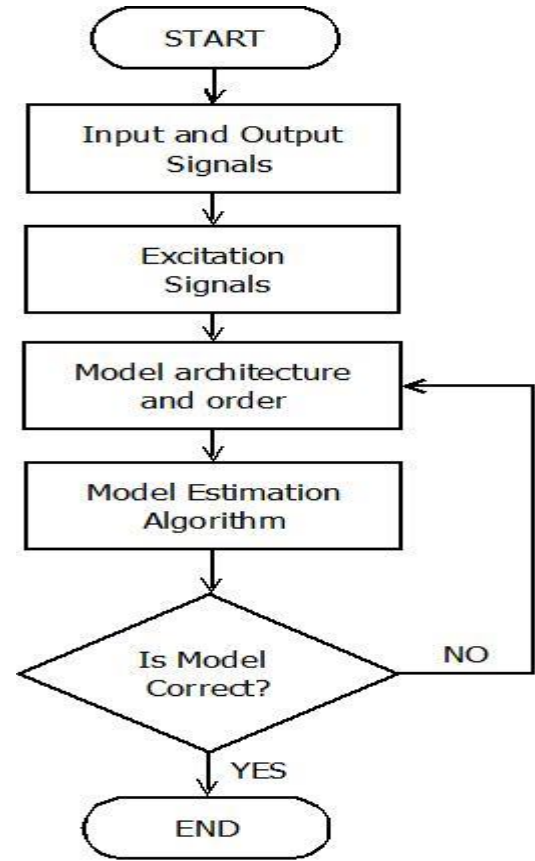

Figure 2 System ID flowchart

The general equations describing the robot are simulated in Matlab/Simulink environment in open loop form, and the input and output data recorded.

2.2 Identification of the TWIP

Grey box method of identification is a statistical method of building models of dynamical systems from measured input and output data and also prior knowledge of the system dynamics [3]. To develop a model using identification approach, the following steps are followed as illustrated in the flowchart in Figure 2:

To get the data used in the identification, the voltage driving the two DC motors of the robot and is used for the input and depending on particular application of TWIP, the outputs can be horizontal position and velocity, the tilt angle and tilt rate, and the yaw angle and yaw rate movement. In this work, two outputs are chosen to be the tilt angle and the horizontal position. The

excitation signal used is a sine wave. The data recorded were used to refine the model in (4) using weighted least square method, by using Matlab *sses* function. An approximate of the refined model to two decimal places is given in Equation 5.

$$Ag = \begin{bmatrix} 0 & -0 & 69.04 & -0 \\ -0 & -0 & 15.82 & -0 \\ 1 & 0 & 0 & -0 \\ 0 & 0 & 1 & -0 \\ 0 & 0 & 0 & 1 \end{bmatrix}, Bg = \begin{bmatrix} 11.55 \\ 4.69 \\ -0 \\ -0 \end{bmatrix}, Cg = \begin{bmatrix} 0 & 0 & 0 & 1 \\ 0 & 0 & 57.3 & 0 \end{bmatrix} \quad (5)$$

3.0 MPC DESIGN

The aim of model predictive control is to bring the predictive output of a system as close as possible to the desired set point [20]. The model of the system is used to predict the future evolution of the system to optimize the control signal. Given a system in Equation 6.

$$\dot{x} = A_m x(t) + B_m u(t) \quad (6)$$

$$y(t) = C_m x(t)$$

We define the auxiliary variables;

$$z(t) = \dot{x}(t) \quad (7)$$

$$y(t) = Cx(t)$$

We choose a new state variable vector $x(t) = [z(t)^T y(t)^T]^T$. The new augmented state model is given in (8):

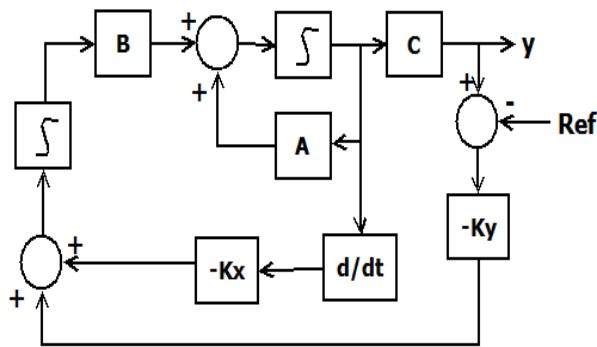

$$\begin{bmatrix} \dot{z}(t) \\ \dot{y}(t) \end{bmatrix} = \begin{bmatrix} A_m & 0^T_m \\ C_m & I_{0qxq} \end{bmatrix} \begin{bmatrix} z(t) \\ y(t) \end{bmatrix} + \begin{bmatrix} B_m \\ 0_{qxm} \end{bmatrix} \dot{u}(t)$$

Figure 3 MPC Block diagram

$$y(t) = \begin{bmatrix} 0_m & I_{q \times q} \end{bmatrix} \begin{bmatrix} z(t) \\ y(t) \end{bmatrix} \quad (9)$$

Where $I_{q \times q}$ is identity matrix with dimension $q \times q$, $0_{q \times q}$ is zero matrix. The new model matrix is

$$A = \begin{bmatrix} A_m & 0^T_m \\ C_m & I_{0qxq} \end{bmatrix}, B = \begin{bmatrix} B_m \\ 0_{qxm} \end{bmatrix}, C = \begin{bmatrix} 0_m & I_{q \times q} \end{bmatrix}$$

The cost function is given in Equation 10

$$J = \sum_{m=1}^{Np} x(k_i + m|k_i)^T Q x(k_i + m|k_i) + \Delta U^T R \Delta U \quad (10)$$

Where Q and R are weighting matrices, and ΔU is future control trajectory with length N_c . N_p is the prediction horizon. The MPC control block is shown in Figure 3. From the figure, it can be seen

that an embedded integrator is added to the design. The optimal gains K_x and K_y were computed using the *lqr* MATLAB command, choosing $Q = C^T C^T$, and $R = 0.1$. The gains computed using the linearized white box model is given in 11, while the MPC gains computed using the grey box model are given in 12.

$$K_x = [-7.7458 \quad -9.4865 \quad -30.2670 \quad -4.1151], \quad (11)$$

$$K_y = [-3.1623 \quad 0.0000]$$

$$K_x = [-9.3453 \quad -16.6703 \quad -42.6428 \quad -10.2680], \quad (12)$$

$$K_y = [-3.1623 \quad 0.0000]$$

4.0 RESULTS AND DISCUSSION

The response of the robot to track step, sine and pulse signal position, using both the linearized and the identified model gains computed in previous section, is shown in this section for comparison.

Figures 4-5 shows the response for tracking step input and the error between the two models. Clearly the grey box model shows better response with less error than the linearized model. Sine wave and pulse signal tracking are shown in Figures 5-7 respectively.

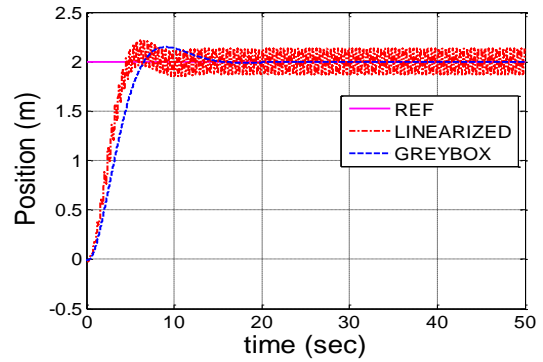

Figure 4 Step response for tracking 1 m

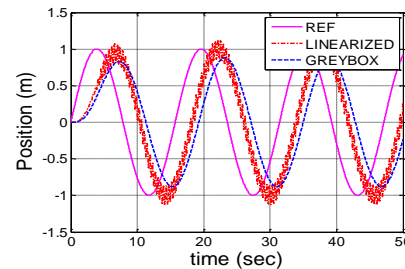

Figure 5 Step response error for tracking 1 m

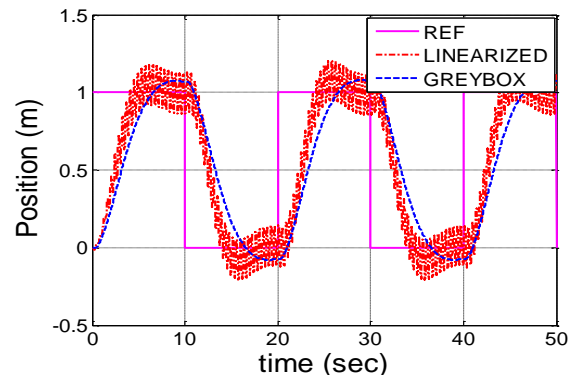

Figure 7 Pulse response tracking

Figure 8 and 9 shows the tilt angle response and the control signal respectively for the step input.

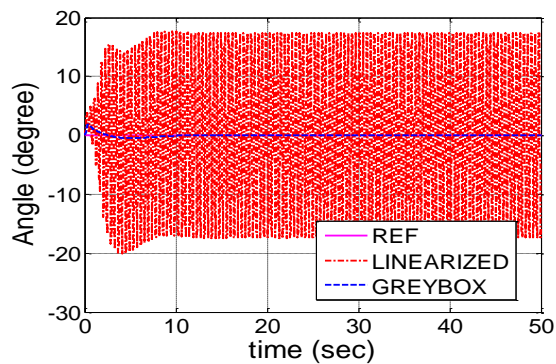

Figure 8 Tilt response for step input

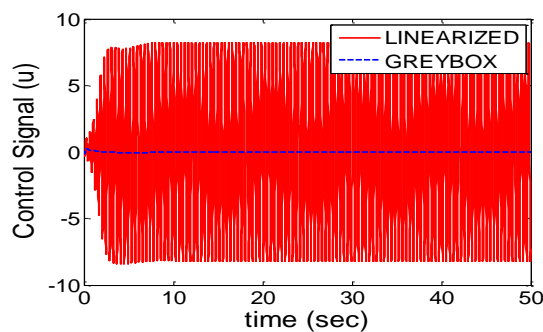

Figure 9 Control signal for step input

It is observed that the response of the TWIP using the feedback MPC gains computed using the grey box model has better smooth response than the linearized model gains, this is clearly seen in the error signal of Figure 5. Since the linearized model is linearized around zero degrees, so the identified model has better operating range than the linearized model, hence better performance in the MPC optimization algorithm.

5.0 CONCLUSION

Position control of TWIP is presented using MPC, the model was developed using identification using grey box technique. Since, the response of the system to various signals were simulated using the gains from both the mathematical linearized model and the grey box identified model, it was found that, the response of the robot using the grey box gains shows a superior performance (smoothness) in terms of practical behavior than the linearized model gains which shows noisy results.

Acknowledgment

These authors are grateful to the Ministry of Higher Education (MOHE) and Universiti Teknologi Malaysia for the financial support through the GUP research fund, Vote Q.J130000.2523.05H40 and special thanks to Bayero University, Kano, Nigeria for their support.

References

- [1] L. Ljung. 1999. *System Identification: Theory for the User*.
- [2] Y. Kim, S. Kim, and Y. Kwak. 2005. Dynamic Analysis of a Nonholonomic Two-Wheeled Inverted Pendulum Robot. *Journal of Intelligent and Robotic Systems*. 44: 25–46.
- [3] R. Xiaogang and C. Jing. 2007. B-2WMR System Model and Underactuated Property Analysis. In *Automation and Logistics, 2007 IEEE International Conference on*. 580–585.
- [4] A. A. Bature, S. Buyamin, M. N. Ahmad, and M. Muhammad. 2014. A Comparison of Controllers for Balancing Two Wheeled Inverted Pendulum Robot. *International Journal of Mechanical & Mechatronics Engineering*. 14: 62–68.
- [5] K. Thanjavur and R. Rajagopalan. 1997. Ease of Dynamic Modelling of Wheeled Mobile Robots (WMRs) using Kane's Approach. In *Robotics and Automation, 1997. Proceedings., 1997 IEEE International Conference on* 4: 2926–2931.
- [6] L. Jingtiao, X. Gao, H. Qiang, D. Qinjun, and D. Xingguang. 2007. Mechanical Design and Dynamic Modeling of a Two-Wheeled Inverted Pendulum Mobile Robot. In *Automation and Logistics, 2007 IEEE International Conference on*. 1614–1619.
- [7] K. M. Goher, M. O. Tokhi, and N. H. Siddique. 2011. Dynamic Modeling and Control of a Two Wheeled Robotic Vehicle with Virtual Payload. *ARPN Journal of Engineering and Applied Sciences*. 6: 7–41.
- [8] M. Muhammad, S. Buyamin, M. N. Ahmad, and S. W. Nawawi. 2013. Takagi-Sugeno Fuzzy Modeling of a Two-wheeled Inverted Pendulum Robot. *Journal of Intelligent & Fuzzy Systems*. 25: 535–546.
- [9] K. Pathak, J. Franch, and S. K. Agrawal. 2005. Velocity and Position Control of a Wheeled Inverted Pendulum by Partial Feedback Linearization. *Robotics, IEEE Transactions on*. 21: 505–513.
- [10] M. Muhammad, S. Buyamin, M. N. Ahmad, S. W. Nawawi, and A. A. Bature. 2013. Multiple Operating Points Model-Based Control of a Two-Wheeled Inverted Pendulum Mobile Robot. *International Journal of Mechanical & Mechatronics Engineering*. 13: 1–9.
- [11] M. Canale and S. Casale-Brunet. 2014. A Multidisciplinary Approach for Model Predictive Control Education: A Lego Mindstorms NXT-based Framework. *International Journal of Control, Automation, and Systems*. 12: 1030–1039.
- [12] J. Jahaya, S. W. Nawawi, and Z. Ibrahim. 2011. Multi Input Single Output Closed Loop Identification of Two Wheel Inverted Pendulum Mobile Robot. In *2011 IEEE Student Conference on Research and Development*.
- [13] G. Y. Morales, S. A. Plazas, and L. F. Combata. 2012. Implementation and Closed Loop Identification of a Two Wheeled Inverted Pendulum Mobile Robot. In *2012 Brazilian Robotics Symposium and Latin American Robotics Symposium, Brazil*.
- [14] M. Muhammad, S. Buyamin, M. N. Ahmad, S. W. Nawawi, and Z. Ibrahim. 2012. Velocity Tracking Control of a Two-Wheeled Inverted Pendulum Robot: a Comparative Assessment between Partial Feedback Linearization and LQR Control Schemes. *International Review on Modelling and Simulations*. 5: 1038–1048.
- [15] K. Min-Sun, J. Chang-Gook, and Y. Dong Sang. 2012. Sliding Mode Control for a Two-wheeled Inverted Pendulum Mobile Robot Driving on Uniform Slopes. In *Control, Automation and Systems (ICCAS), 2012 12th International Conference on*. 2159–2162.
- [16] Q. Haa, P. Li, Y. Z. Chang, and F. Yang. 2011. The Fuzzy Controller Designing of the Self-Balancing Robot. In *IEEE International Conference on Electronics and Optoelectronics*. 3: 16–19.
- [17] H. Cheng-Hao, W.-J. Wang, and C. Chih-Hui. 2011. Design and Implementation of Fuzzy Control on a Two-Wheel Inverted Pendulum. *Industrial Electronics, IEEE Transactions on*. 58: 2988–3001.
- [18] W. Junfeng and J. Shengwei. 2011. T-S Adaptive Neural Network Fuzzy Control Applied in Two-wheeled Self-Balancing Robot. In *Strategic Technology (IFOST), 2011 6th International Forum on*. 2: 1023–1026.
- [19] T. Ching-Chih, H. Hsu-Chih, and L. Shui-Chun. 2010. Adaptive Neural Network Control of a Self-Balancing Two-Wheeled Scooter. *Industrial Electronics, IEEE Transactions on*. 57: 1420–1428.
- [20] L. Wang. 2009. *Model Predictive Control System Design and Implementation Using MATLAB*. London: Springer-Verlag London Limited.