

The Application of WiFi-based Wireless Sensor Network (WSN) in Hill Slope Condition Monitoring

Mohd Amri Md Yunus*, Sallehuddin Ibrahim, Mohd Taufiq Md Khairi, Mahdi Faramarzi

Protom-i Research Group, Infocomm Research Alliance, Control and Mechatronic Engineering Department, Universiti Teknologi Malaysia, 81310 UTM Johor Bahru, Johor, Malaysia

*Corresponding author: amri@fke.utm.my

Article history

Received :15 August 2014
Received in revised form :
5 January 2015
Accepted :10 February 2015

Graphical abstract



Abstract

In this paper, a wireless sensor network for landslide monitoring (WSNLM) system is described. WSNLM utilized a wireless protocol which is 802.11g. The hardware structure of the WSNLM is discussed where the important parts had been discussed in details. In order to assess the susceptibility of a hill slope to landslide, several parameters had been considered for the network. The important factors that affect landslide is the ground status, which is soil moisture, vibration in the land and also soil temperature. Other factors that can relate to landslide is the environment of the surrounding such as air temperature, humidity and atmospheric pressure. The outputs from the ADXL335 accelerometer were used for slope angle measurement. The output of a vibration transducer was also used to monitor the hill slope. To account for the susceptibility of the hill slope to the land slide, safety factor value is calculated in real time. The outcomes show that the average moisture content in the soil is around 3 % on a sunny day and the safety factor for a sunny day is around 75. The moisture content in the soil on a rainy day increases tremendously to more than 20 %. At the same time, the safety factor drops to around 70. The system in this paper has the potential to be used as a useful tool for the detection of lanslides.

Keywords: WiFi; 802.11g; wireless sensor network; WSN802G modules; hill slope monitoring; humidity measurement; atmospheric pressure measurement; soil moisture content; low cost vibration transducer

© 2015 Penerbit UTM Press. All rights reserved.

1.0 INTRODUCTION

Landslide can be defined as the collapse of a mass of earth or rock from a mountain or cliff. It has always been a major problem in many countries, including Malaysia. There are two factors that contribute to landslide; natural factors and human related factors. Both of these factors, if occur can bring catastrophic effect to the environment and settlement in an area [1]. For example, in Malaysia alone, there is more than 500 casualties reported from 1990 to 2007 due to this event [2]. These casualties can be eliminated if the people was notified earlier about the danger.

In order to overcome this problem, the Malaysian Public Work Department had launch a slope safety campaign in order to teach the public for signs of landslide. However, in practical, it is hard to teach every person to understand the signs and be aware about the importance of early signs. For a more proper monitoring system, researchers from all over the world have conducted many methods to monitor landslide in real time. Among the most well-known approaches is remote sensing technique where it uses radar and satellite to monitor any movement on the ground [3]. There is also deep earth probing system where it buried sensor deep inside the area prone to landslide to monitor several parameters such as moisture, water content and ground movement [3]. Some of the monitoring systems have been

successfully commercialized and are available in the market such as the Slope Stability Radar (SSR).

A Wireless Sensor Network (WSN) can be broadly described as a network of nodes that makes a collaborative effort in sensing certain specified data around its periphery and thereby control the surrounding and the surrounding environment [4].

The first WSN system began its use in 1950's and it is called Sound Surveillance System (SOSUS). It is used by the US to detect and track Soviet submarine in the cold war [5]. Then in 1980's, United States Defend Advance Research Project Agency (DARPA) started the Distributed Sensor Network (DSN) research and soon after WSN technology was founded and from that many other researches have been completed [5]. In the coming years, WSN has found its way into the heavy industrial market such as power distribution, waste water treatment and many others.

Nowadays, WSN has been used in many applications. Whether in the industry to everyday thing WSN will come around as a vital instrument to measure the surrounding environments. One of the applications is the disaster relief application such as landslide monitoring and also tsunami or hurricane monitoring [6]. Other than that, WSN can be found in environmental control. For example WSN is used to monitor agricultural area [7, 8]. A

WSN is designed to detect events or phenomena, collect and process data and transmit the sensed information to a server [6].

To further benefit the usage of WSN, researches on this subject have been very fast from the development of better sensor to having a smaller, low cost, as well as low power microcontroller and transmitter. Wireless sensor and “smart transducer” are sensors equipped with microcontrollers to provide intelligent and network capability. Standardization efforts initiated by the National Institute of Standards and Technology (NIST) have led to development of the IEEE 1451 standard which address the integration of smart transducer with various communication protocol. In the future, we will see that sensors and transducer becoming smaller and smarter with the ability to communicate with other device wirelessly [9].

Therefore, the development of landslide monitoring using wireless sensor network is needed. This is because wireless can monitor remote area without collecting data manually on the landslide prone area. Precious data can be transferred real-time from the landslide area to a control room. Real-time monitoring on a landslide monitoring system is greatly needed to develop an early warning system before a landslide occur.

2.0 REAL-TIME WIRELESS SENSOR NETWORK FOR LANDSLIDE DETECTION

A WSN was developed to detect landslide which include design, development and implement of WSN for real time monitoring, the development of algorithm needed that will enable efficient data collection and data aggregation as well as the network requirement of the deployment landslide detection system [10]. The WSN architecture is shown in Figure 1. In the architecture system WSN follows a two-layer hierarchy, with lower layer wireless sensor nodes sample and collect heterogeneous data from sensor column. The data packet is then transmitted to the upper layer. The upper layer aggregates the data and forward it to the sink node (gateway) kept at the deployment site. Data received at the gateway is then transmitted to the Field Management Centre (FMC). A Wi-Fi network is used between the gateway and FMC to establish connection. The FMC incorporates facilities such as a VSAT (Very Small Aperture Terminal) satellite earth station and a broadband network for long distance data transmission. The Data Management Centre (DMC) consists of the database server and an analysis station which perform data analysis and landslide modelling and simulation on the field data to determine the landslide probability [10].

In Figure 1, we could find that the two-layer hierarchy algorithm could be the answer if we want to deploy a more accurate landslide monitoring system in a remote area. By using this algorithm the data are more accurate compared to using a single WSN node. For future development of the system, this algorithm is a way to improve the usage of WSN in a remote area. The relay node can be improved by linking a node between each other rather than having a single node transferring data to the gateway. This way, even if a relay node had a broken connection between the node and the gateway, it can send the data between other nodes first. Thus data will not be lost even when a relay node have a broken connection [11].

Two ways of communicating between Fixed-Mobile Convergence FMC and server can be used to avoid data loses [12]. In this system, the communication is interchangeable. It first uses General Packet Radio Service (GPRS) to transfer data to the server. If GPRS fails the system automatically switch to WLAN to transfer the data. This double protective way will ensure that no data is lost.

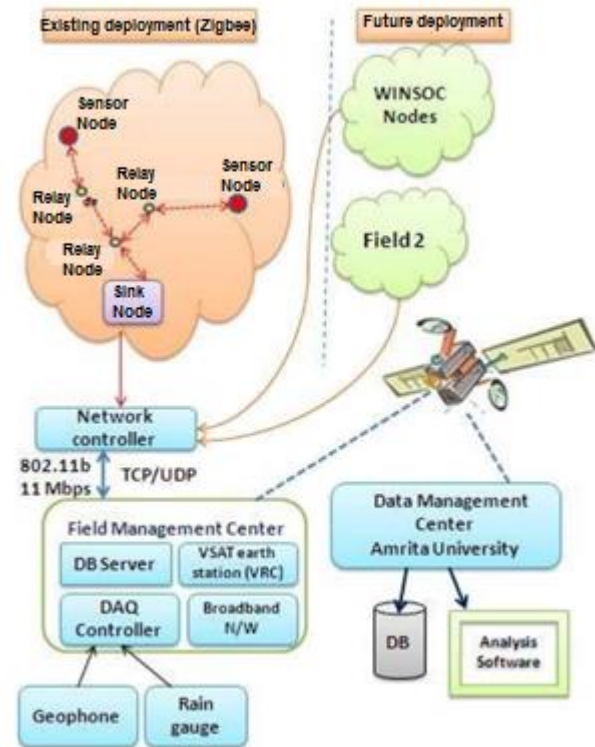

Figure 1 Wireless sensor network architecture for landslide detection [11]

3.0 LANDSLIDE SUSCEPTIBILITY ANALYSIS

Measurement and recording of data related to the physical change of the earth's surface are vital to detect the occurrence of landslide. There are a lot of techniques that had been used over the years for this purpose. Many instrument and techniques have been developed to monitor the deformation of structure of the ground surface displacement [3].

Remote sensing or satellite technique uses satellite image to produce maps for the assessment of landslide. One of the examples using maps for assessment of landslide is Synthetic Aperture Radar (SARS) where it remotely sensed measurement of ground displacement by capturing images of the hill slope [13]. Then using image from satellite, it map the hill slope and further analysis could be carried out.

Ground based geodetic techniques for landslide monitoring had been used for deformation monitoring of structures and landslide. Sensor based Landslide Early Warning System (SLEWS) uses this technique to monitor landslide. SLEWS scattered WSN node to detect the mass movement [14].

Global Positioning System (GPS) can also be used to monitor landslide. It can provide 3D coordinate time series of displacement at discrete point on the sliding surface [3]. GPS system calculate the position of the user using a values observables [15]. In order to capture 3D image of an area, several units of GPS module had to be place around the designated area. Then each data that the GPS receive had to be mapped for analysis.

The landslide monitoring technique needs to be assessed to predict landslide occurrence. The parameter of soil properties measure the soil strength. This includes dry unit weight, friction angle, and Standard Penetration Test (SPT) value of soil deposit. Land use suitability parameter consists of two geotechnical aspects which are slope hill development and slope gradient. This parameter is used to predict the impact of land development to

the people and environment. Most common parameter used to predict slope failure is the safety factor parameter. The lower the value means the land is not stable [16].

Geospatial Information System (GIS) is a computer software system that enables users to capture, store, analyse and manage spatially referenced data. Some of the commercial system such as ARC/INFO, Intergraph, SPANS, ILWIS IDRISI are available for this purpose. Remotely sensed data are integrated with GIS to assess landslide hazards. Data then can be analysed and model inside GIS [17].

There are several factors that affect the landslide susceptibility. First is lithology, which is the physical characteristic of the earth. The physical characteristic of the earth can affect landslide because different soils have different cohesive strength, density, unit weight and etc. Second is slope gradient, where the slope gradient increases as the shear stress or residual soil increases. The slope direction also can have effect on landslide susceptibility because, different direction may have different sunlight exposer, drying wind, and rainfall distribution. Third is elevation, where high elevation mountains are usually characterized as whether rock and the shear stress is much higher. At the intermediate level, slope tends to be covered by thin colluvium which is more prone to landslide. Fourth is vegetation cover, where places like woody type area with strong and big root system tend to helps the stability of a slope. Lastly is the proximity to drainage line. It is found that terrain modification caused by gully erosion may influence the initiation of landslide [18].

4.0 DESCRIPTION OF WIRELESS SENSOR NETWORK FOR LANDSLIDE MONITORING (WSNLM)

Figure 2 illustrates the hardware architecture of the wireless sensor network for landslide monitoring (WSNLM) system which comprises of 3 parts: hill slope parameter sensing, saving data, and sending data. The software part consists of analysis and display. Seven parameters were measured for landslide monitoring are vibration, slope angle, soil moisture, soil temperature, and atmospheric condition (humidity, temperature and pressure). The data is then transferred to a computer through a router for analysis.

WSN802G is the heart for WSNLM. The wireless sensor network uses RFM WSN802G. It is a low powered wireless

transceiver that uses 802.11g wireless protocol. It also have very low current deep sleep mode. The module includes analog, digital, serial, and SPI I/O, providing the flexibility and versatility needed to serve a wide range of sensor network applications [19]. The data is transferred serially from the microcontroller to the serial memory inside WSN802G. WSN802G transmitted the data that it had captured and send it wirelessly to the intended computer via a gateway. The gateway which was the router act as an entrances to another network because WSN802G and the computer WI-FI used different base protocol.

Data sent by WSN802G was in UDP packet data for I/O Reporting and SNMP packet when they were used to configure linkup trap. Linkup trap was to ensure that WSN802G was always connected to the gateway. This packet could be sniffed using a sniffing software like Wireshark [8]. The UDP Packet data is divided into bytes to separate the sensors data.

WSN802G had a very low power consumption when it is in the sleep mode. Therefore, making sure that WSN802G is always in the sleep mode is crucial to prolong the battery lifetime. There are several ways to wake WSN802G up which is by setting high to the WAKE_IN pin, auto report interval is expired, and *linkup* and *config_trap* is expired. Thus to save power, data that is serially sent from Arduino to WSN802G will come in parallel with the auto report interval time to send data wirelessly to the server. Therefore, right after I/O Read packet data is sent I/O Serial Read packet data is also being transferred. This could be done when WSN802G is awake, the WAKE_OUT pin is HIGH and this will be the trigger for the Arduino to send data serially that had previously been saved.

4.1 Arduino Programming

An Arduino UNO microcontroller is used to obtain the input from the sensor and perform switching between sensors, temporary save the input data, encoded the data into simple-to-decode packet, and send the data using UART communication to WSN802G. There were two crucial functions in programming the Arduino which were **setup()** and **loop()**. **Setup()** is where the pin is declared as either an input or an output and also the serial speed is declared by using **Serial.begin** function. **Loop()** is the body of the program. It will loop infinitely until the stopped instruction is sent.

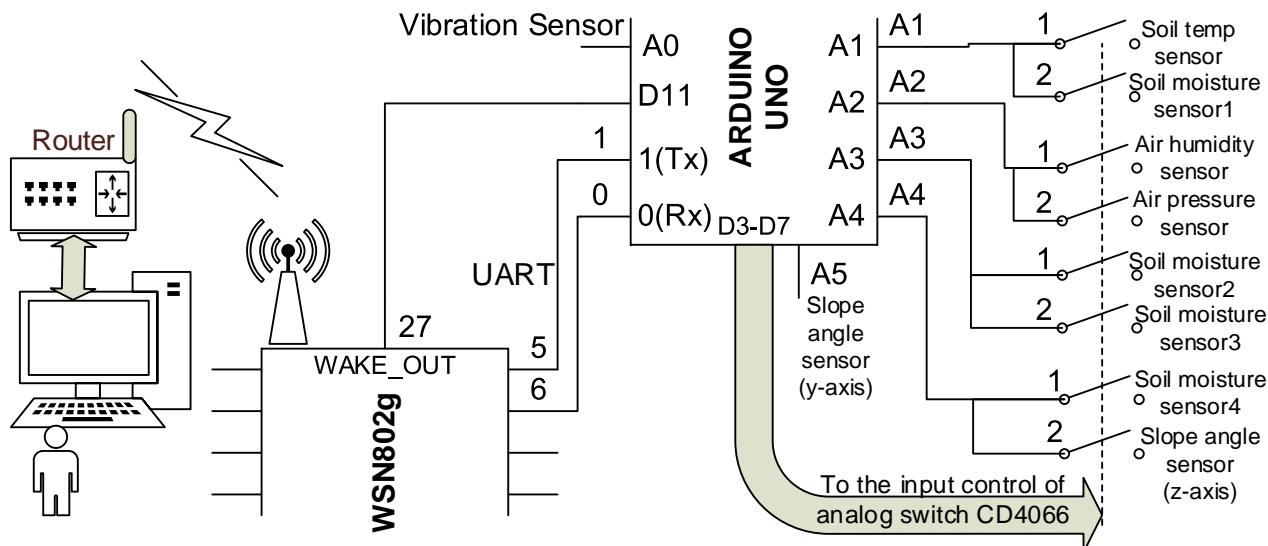

Figure 2 Wireless sensor network for landslide monitoring (WSNLM) block diagrams

4.1.1 Input, Switch, and Save Signals

In order to read input from the sensor, the **analogRead()** function was used. Input is read one at a time. First of all, the input is read from the vibration sensor through Arduino's analog input, labelled A0. Then, in quick succession, the signals from the other sensors are read before universal asynchronous receiver/transmitter (UART) data transfer. The **analogRead()** function converts an analog voltage signal into 10-bit digital signal, which means an analog voltage input with a value between 0 to 5 V is mapped into an integer value between 0 to 1023. It takes about 100 microseconds to sample and convert a data.

After the analog signals of the vibration were successfully read, Arduino will switch on the first switch that was connected to each Arduino's analog inputs, labelled A1 through A4 by writing HIGH value to the corresponding first analog switch's control input as shown in Figure 2. The **digitalWrite()** function was used to program the Arduino's digital output, labelled D3 through D7 to give 5V or 0V when HIGH command or LOW command was sent, respectively. After all analog signals had been successfully read, Arduino will switch off the first switch that connected to each Arduino's analog input, labelled A1 through A4 and turn on the second switch that was connected to each Arduino's analog input, labelled A1 through A4. This process is repeated until all analog signals from all sensors had been sampled. A part of the switching program is shown in Figure 3.

Arduino was also used to send data via universal asynchronous receiver/transmitter (UART) to WSN802G. However, Arduino is a 5V system, but WSN802G is a 3.3V device, thus, some signal conditionings were required. Therefore, a logic convertor system, LC04A was used. Figure 4 shows the functions for the serial communication on the Arduino.

Saving data inside the Arduino could be done by using an array. It collects multiple inputs using the same name, and each input is accessed using an index number. The data is saved inside the Arduino's Flash memory of 32 kB. In order to create an array first, it must be declared as follows:

Example: int sensorValue[97];

The **int** stand for the data type of the array **sensorValue** is the name of the array and 97 is the size of the array. We can assign a value into an array by:

Example: sensorValue[88] = analogRead(A1);

where the analogue value of A1 is assigned into an array element numbered as 88. Any value from the A1 will be the value for the array element of 88. In the following example, the data is retrieved:

Example: LOWORD = lowByte(sensorValue[i]);

In this phrase of the code, we take the low byte value of an array element of *i* into the variable of LOWORD.

4.2 Encoded Data Distribution

The saved set of data was sorted for ease of the decoding process afterward. This refers to putting the set of data into a predetermined order. For example, the analog signals from the vibration sensor are sample first, then follows by the analog signal from the soil temperature sensor and after that, the analog signal form the humidity sensor etc. The full data set for this project was distributed into 192 bytes. Each data consumes 2 bytes because Arduino's ADC represents the data readings in

words of 10 bits. Therefore, there are only 96 bytes pair of memory available. 98 bytes pair of data are divided into 88 bytes pair for vibration, a byte pair for soil temperature, a byte pair for air humidity, a byte pair for air pressure, a byte pair for air temperature, a byte pair for slope and another 3 bytes pair for 3 moisture sensors each as shown in Figure 5. Effective vibration analysis requires an accurate time-varying signal from a vibration transducer, therefore, 88 samples were acquired to attain a good accuracy of vibration analysis.

```
...
...
digitalWrite(3,HIGH);
delay(1);
sensorValue[88] = analogRead(A1);
digitalWrite(3,LOW);
digitalWrite(4,HIGH);
delay(1);
sensorValue[89] = analogRead(A2);
digitalWrite(4,LOW);
...
...
```

Figure 3 Switching the first switch that connected to each Arduino's analog inputs, labelled A1 and A2

```
for(i = 0; i <= 95; i++)
{
    LOWORD = lowByte(sensorValue[i]);
    Serial.write(LOWORD);
    delay(1);
    HIWORD = highByte(sensorValue[i]);
    Serial.write(HIWORD);
    delay(1);
}
```

Figure 4 UART codes to execute the serial communication between Arduino and WSN802G

The seismic low-frequency signals is about 0.5 to 25 Hz; therefore, the measurement sampling frequency was set at around 143 Hz. Moreover, the whole set of data in one complete cycle needs to be sampled in about 1 s. The timing for other data and gap for data transfer serially also need to be considered. Therefore, a delay of 7 ms is the best sampling time for each data set. For the vibration sensor, the sampling process will be completed in 0.616 s with considerable stability.

The slope sensor employs ADXL335 accelerometer. The ADXL335 is complete 3-axis acceleration measurement system. The ADXL335 has a measurement range of ± 3 g minimum. The output signals are analog voltages that are proportional to acceleration. The accelerometer can measure the static acceleration of gravity in tilt sensing applications as well as dynamic acceleration resulting from motion, shock or vibration. The ADXL335 converts the y and z axes accelerations into x-axis angle of θ_x . The calculation was carried out in Arduino. After the data had been converted into angle, the data is converted again into 16 bits binary data before it is saved inside the array. 16 bits data was used so that it will be converted back into angle accurately while maximizing the space available.

$$\theta_x = \arctan\left(\frac{-y}{-x}\right) \times \frac{180^\circ}{\pi} + 180^\circ \quad (1)$$

where θ_x is the x-axis angle in $[\circ]$, y is the output voltage of y-axis acceleration in [V], and z is the output voltage of z-axis acceleration in [V].

The main problem in sending the data to the WSN802G is the timing. The data array needs to be sent right after WSN802G wake up and sets the WAKE_OUT pin HIGH to trigger the data array transfer from Arduino. If the length of the data array is too long, it will affect the next data sampling. Data sampling time frame is set around 0.9 s.

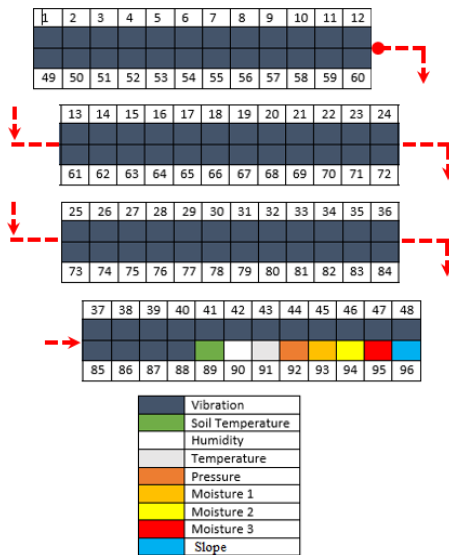

Figure 5 Encoded data distribution

4.3 Factors of Interest and Sensors

The system investigates some essential factors for landslide susceptibility measurement:

- Hill slope vibration,
- Soil moisture,
- Slope angle,
- Soil temperature,
- Atmospheric condition (humidity, temperature and pressure).

Landslide is a descent of a mass of earth and rock down a mountain slope. Landslides refer to soil, rock, and also sliding downhill. It mainly happen by rainfalls which cause increment of water presence in fresh lenses. An effective forecasting action, which is a crucial activity to provide timely alarms, must be able to deal with such physical phenomena characterized by a significant difference in the dynamic properties of soil by seismic vibration measurement. In this study, a low cost seismograph was developed using a loudspeaker transducer for seismic vibration measurement. A set of weights placed on the cone turns the loudspeaker into a vibration sensor, as shown in Figure 6. When the loudspeaker picks up seismic waves, the weights stay at the same place and exert force on the cone, and thus the distance between the coil and the base of the center pole will change. Consequently, an output voltage is generated at the output terminal of the loudspeaker. The performance of the vibration sensor is determined by the effect of the total force exerted by the weight's total mass on the elements of the loudspeaker.

In this study, a Visaton FR8 8 ohm loudspeaker was used throughout the work. It has a diameter of 8 cm and 10 W / 8 Ω.

An M16 × 65 metric bolt is used to weigh down the cone, as illustrated in Figure 5. Several nuts were added to the weight on the bolt.

Figure 7 depicts a schematic of the signal conditioning circuit. Two non-inverting amplifiers each using a dual op-amp were used to amplify the loudspeaker sensor output signal. The total gain was divided across the non-inverting amplifiers to minimize the effect of the input offset voltage of the bipolar op-amps. The output signal from the pre-amplifier circuits is then input into a filter circuit that used a MAX7403 chip, which is an eight-order low pass elliptic switch capacitance filter. V_o represents the final output of the vibration sensor in Volt.

Rapid changes of amount of water in the soil can trigger landslides. This water will seep into the soil and occupied the holes or pores in the soil, thus cause the rock and sediments to loosen and fall down. Therefore, a soil moisture sensor was designed. Three sensors were buried into the soil in three locations in the ground around 2 m depth. These three locations are situated at different places in order to estimate the direction of the water flow in the soil. Each soil moisture sensor was created by using a white gypsum plaster and two galvanized nails as anode and cathode terminal to measure the soil moisture. Figures 8(a) and (b) show the moisture sensor and the circuit for the moisture sensor, respectively. From an experiment, the characteristic equation of the sensor is given by:

$$V_s = -0.0054M + 0.5736 \quad (2)$$

where V_s is the output of the sensor in Volt and M is the percentage of soil moisture in %.

ADXL 335 was used to calculate the slope angle as explained in sub-section 4.2. The soil temperature was measured using a GE2SENSOR-40 thermistor. For the atmospheric conditions, Honeywell's HIH-4010-004, Motorola's MPXA4115A and LM35DZ were used to measure the humidity, pressure and temperature respectively.



Figure 6 A photo of weights attached on the cone of a loudspeaker

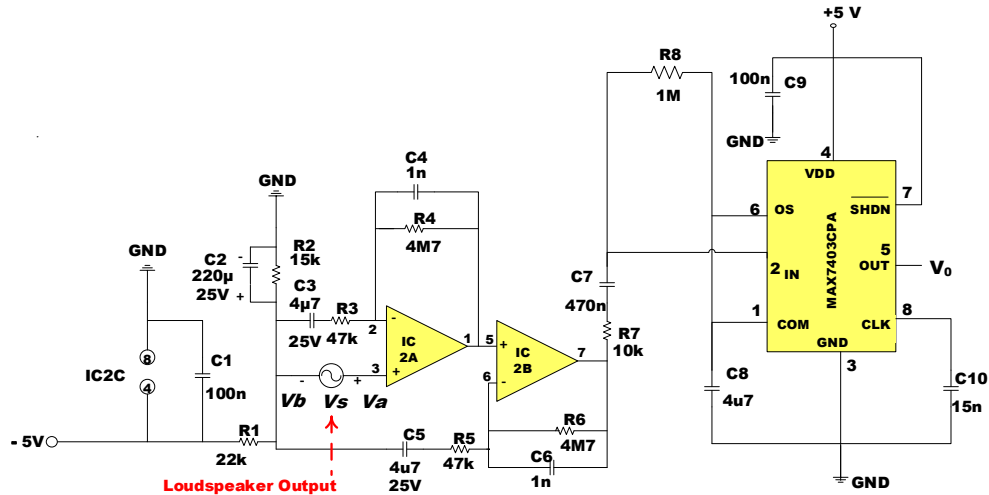

Figure 7 The signal conditioning circuit of the vibration transducer received the input from the loudspeaker output

5.0 LANDSLIDE SUSCEPTIBILITY BASED ON SAFETY FACTOR

For landslide susceptibility analysis of the hill slope, the safety factor value is calculated in real time. It is suggested that, if the safety factor value is more than 1 then the slope is stable. If the safety factor value is less than 1, then there is a possibility that it would collapse depending on the persistency. The safety factor is calculated based on the following equation [20]:

$$FS = \frac{c_s}{W \sin \theta} + \frac{\tan \phi}{\tan \theta} + \frac{u \tan \phi}{W \sin \theta}$$

$$W = (\gamma_t (H - h) + \gamma_{sat} h) \cos \theta \tag{3}$$

$$u = \gamma_w h \cos^2 \theta + u_r$$

where, *FS* is the safety factor, *c_s* is the effective soil cohesion [kN/m²], *H* and *h* are the depth of the soil and water [m], *φ* is the internal friction and *θ* is the slope angle [°] *γ_w* is the unit weight for water, *γ_{sat}* is the saturated unit weight of the soil, *γ_t* is the unit weight for soil [kN/m³]. *u* is the pore water pressure, *u_r* is the pore liquefaction pressure due to soil moisture and vibration energy [21], given by the following equation:

$$u_r = 80 \text{ kPa} \left(\left(\frac{V_o}{5 \text{ Volt}} \right)^2 + \left(\frac{M'}{100\%} \right)^2 \right)^{-1/2} \tag{4}$$

where *V_o* is output voltage from the vibration transducer, *M'* is the average soil moisture in % from soil moisture 1, soil moisture 2, and soil moisture 3.

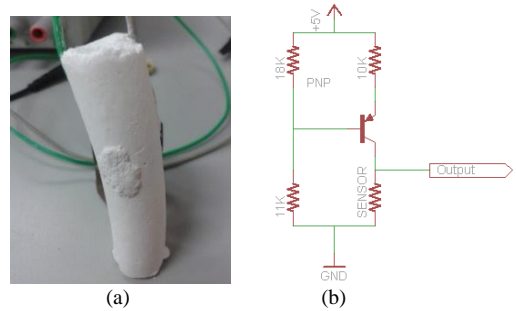
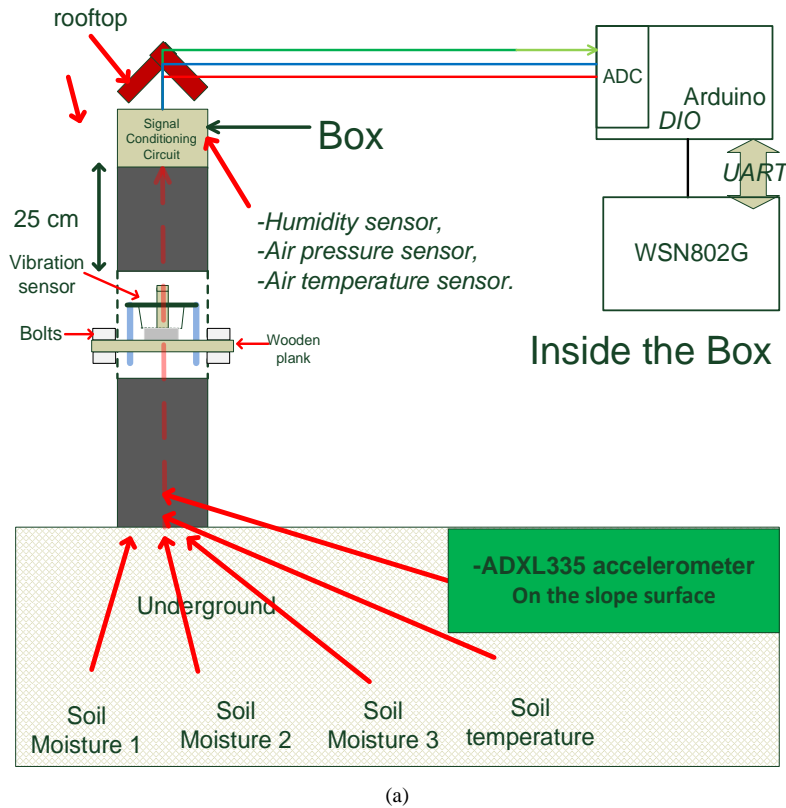

Figure 8 (a) A soil moisture sensor (b) Soil moisture sensor circuit

The WSNLM system was deployed near P10 building, faculty of electrical engineering, Universiti Teknologi Malaysia. It was set there because there is a slope next to the P10 building. Figure 9 shows the conditions of the experimental area and the block diagram, which shows a tower made of mild steel square hollow section with outer dimensions of 10 mm × 10 mm × 3 mm × 1500 mm and a bolted roof. The sensors and circuits were placed inside the box and around the tower. The tower was bolted into the ground so that it will be stable even if there is a storm as shown in Figure 9(b).

Two conditions were considered in the experiment. The first condition is when there is no rain. The second condition is when it is raining. Both data will be compared side by side for analysis. These two conditions were compared because landslide typically occur during rainy season, therefore capturing data during raining is important. The data during no rain served as a reference.



(b)



(c)

Figure 9 (a) The experimental setup and the block diagram which shows a tower made of mild steel square hollow section with outer dimensions of 10 mm × 10 mm × 3 mm × 1500 mm and a bolted roof (b) A photo of the experimental area on top of the slope and around the tower (c) A photo of the hill slope area

The sensors were placed on or inside strategic places to monitor the condition of the hill slope. The circuit boards were placed inside a PVC box container to protect the circuit boards as shown in Figure 9(a). Three moisture sensors were buried about 1 m deep inside the ground to measure the water moisture of the ground. In this particular application, three moisture sensors were enough to cover the hill slope area. A soil temperature sensor also was buried same depth as the moisture sensor. Air humidity, temperature and pressure sensors were placed at the top and outside the PVC box to measure the surrounding atmosphere. An accelerometer for slope sensor was placed on the slope surface. Lastly, the vibration sensor was bolted on a piece of plank and placed inside the tower about 250 mm under the PVC box, as shown in Figure 9(a). The conditioned signal of the vibration sensor is input into one of the Arduino analog inputs.

The condition and soil type of the ground was identified before any experiment to determine the *FS* coefficients in Equation (3). Therefore, from the investigation, the effective soil cohesion, c_s is 18 kN/m². The depth of the soil, *H* and water, *h* are 3m and 1m, respectively. The internal friction, ϕ is 30°, the unit weight for water, γ_w is 19 kN/m³, and the unit weight for soil, γ_t is 18 kN/m³. These coefficients values will be used to calculate the safety factor in Equation (3).

The experiment was conducted for three hours in a normal day without rain. Then, another experiment was conducted for one hours during rainy day.

6.0 RESULTS AND DISCUSSION

Tests were performed to check the relationship between the Receive Signal Stretch Indicator (RSSI) transmitted by the

WSN802G module during a normal day and a raining day. Test were performed by logging the transmitted RSSI values during normal day and raining days. The RSSI values during normal day and raining day are $-25 \text{ dBm} \leq \text{RSSI} \leq -5 \text{ dBm}$ and $-30 \text{ dBm} \leq \text{RSSI} \leq -70 \text{ dBm}$, respectively. RSSI with relation to weather conditions vary more significantly especially during raining day. Though the RSSI-based method can be influenced by environment (weather), WSN802G module could still provide adequate results in an outdoor environment.

Figure 10 shows the GUI for WSNLM. Each graph shown in Figure 10 is based on the physical unit against time. To change from 10 bits analogue input into physical unit, each sensor will undergo through some conversion. All of them will first convert the 10 bits analogue input into the corresponding voltage before change into each physical unit. Data is save from LabVIEW into a .csv file. A .csv file can be opened with software like Microsoft Excel an alike. To save data into a .csv file, the data is first group together into one array of data. Then, using Write to Spreadsheet File VI function, data is saved into a specific file inside the server.

The graphs in Figure 11 shows the temperature of the soil and air for an hour. It can be seen that, the temperature on a sunny day is around 34 to 29 °C where else, on a rainy day the average temperature was around 27 °C. The soil temperature follows the air temperature where when the air temperature decreased the soil temperature also decreased but at a later stage. This is due to the fact that the soil takes time to heat up.

Figure 12 shows the humidity and atmospheric pressure around the experimental area. It can be seen that there is an increase in humidity between a normal day and a rainy day. This is because when it rains, the humidity increased. It is also true that during a normal day humidity in Malaysia is around 78 % according to the Malaysian Meteorology Department. For the

atmospheric pressure, it can be concluded that, there was no significant difference between a sunny day and a rainy day as the trend lines in Figure 12 are overlapped at around slightly over 100 kPa.

Figure 13 shows the moisture that had been measured and safety factor that had been calculated from Equation (3). The angle of the slope is 17°. The average moisture content in the soil is around 3 % on a sunny day and the safety factor for a sunny day is around 75. The moisture content in the soil on a rainy day increased tremendously to 19 % and later increases to more than 20%. At the same time, the safety factor drops to around 70. This

drop is contributed by the soil moisture increments. It can be seen that, the drop on safety factor is significant during the raining day and the safety factor could decrease even further if the raining season persist for a long period of time. The physical unit measurements in Figures 11 to 13 were carried simultaneously and it can be concluded that the soil temperature, air temperature and air humidity are directly correlated with the safety factor. It is still early to indicate whether the slope is unsafe, however, the correlation between the soil moisture contents with rainy days can clearly be seen.

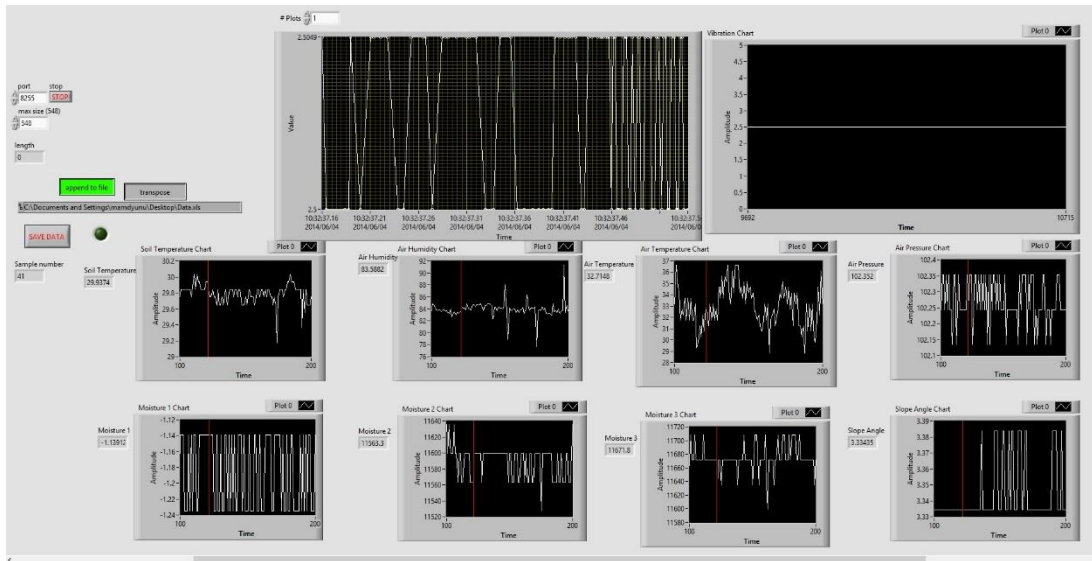

Figure 10 The Graphical User Interface of Wireless Sensor Network for Landslide Monitoring (WSNLM)

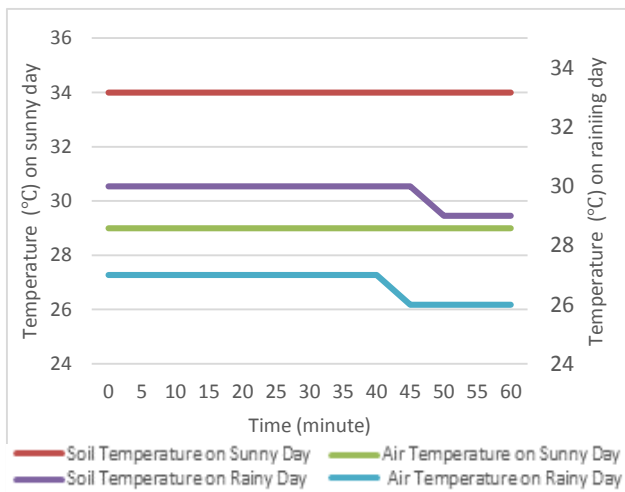

Figure 11 Soil and air temperature on a sunny and rainy day

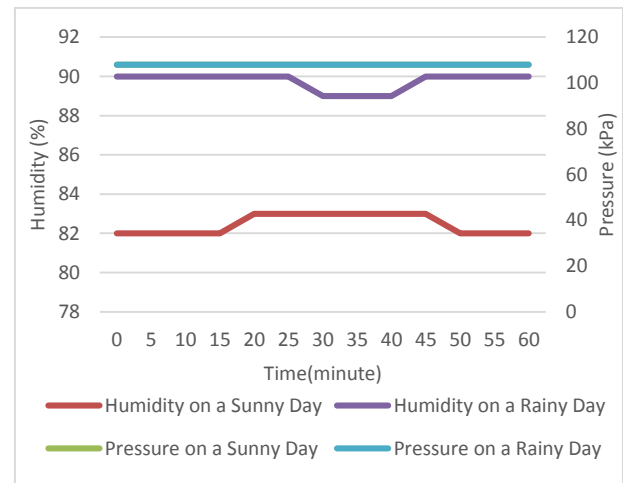

Figure 12 Humidity and pressure on a sunny and rainy day

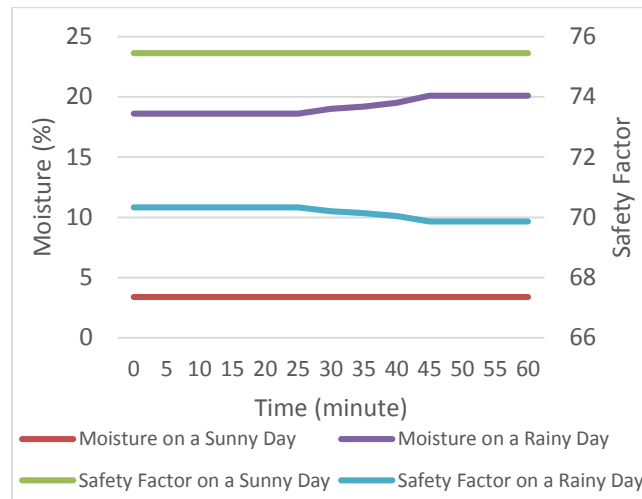

Figure 13 Moisture and safety factor on a sunny and rainy day

7.0 CONCLUSION

A Wireless Sensor Network for Landslide Monitoring (WSNLM) is about monitoring landslide activity in hill slope where the data is sent using wireless 802.11g protocol. Landslide is a prevalent problem in Malaysia. Many lives, valuables, and assets had been lost due this catastrophic event. Even so, there is still no early detection mechanism to warn the population of this impending disaster. Therefore, this sensor network will be a platform for future development on the problem.

WSNLM made use of the widest used wireless protocol which is 802.11g. Implementing this protocol will ensure the safety and reliability of collected data that has been sent. In order to detect the landslide, several parameters had been considered for the network. The important factors that affect landslide is the ground status which is soil moisture, vibration in the land and also soil temperature. Other factors that can relate to landslide is the environment of the surrounding such as air temperature, humidity and atmospheric pressure.

Therefore, data from these parameter is collected. Collected sensors data will then undergo another 3 process which is saving, sending, and showing. The first part, saving used Arduino flash memory to save data collected by the sensor. The data is encoded into one packet before it is send wirelessly using WSN802G. There is 96 word of data that is send for one packet. The data is split into 88 word for vibration sensor and 1 word each for another 8 sensors. One packet of data has a time frame of 1 second. This is to conserve power as fewer packet being send will consume less power. The vibration sensor is sampled at 8 milliseconds. There is a gap of 10 milliseconds between sampling of data and sending of data. This is to ensure stability for the system. The graphic user interface (GUI) was built using LabVIEW. The WSNLM system has been successfully developed. Tests conducted showed that it can record essential information such as temperature, humidity, pressure, moisture and vibration which are vital parameters that indicate the occurrence of landslide.

WSNLM had proven that it can monitor landslide. However with some adjustment and more research WSNLM can be used in for the masses. WSNLM method on switching, saving and sending is a great way to achieve more data from many different input therefore the system is more robust. Monitoring slope stability and this method had been proven accurate

Acknowledgement

The authors wish to acknowledge the assistance of Universiti Teknologi Malaysia under the GUP Research Vote 08J88 for providing the funds and resources in carrying out this research.

References

- [1] S. G. Evans and J. V. DeGraff. 2002. *Catastrophic Landslides: Effects, Occurrence, and Mechanisms*. Geological Society of America. 15.
- [2] M. P. W. Department. 2009. *National Slope Master Plan 2009–2023*. Kuala Lumpur.
- [3] P. D. Savvaidis. 2003. Existing Landslide Monitoring Systems and Techniques. *From Stars to Earth and Culture. In honor of the memory of Professor Alexandros Tsioumis. The Aristotle University of Thessaloniki, Greece*. 242–258.
- [4] H. K. Patil and S. A. Szygenda. 2012. *Security for Wireless Sensor Networks Using Identity-based Cryptography*. CRC Press.
- [5] N. Vyas and R. Shah. 2014. Intelligent and Efficient Cluster Based Secure Routing Scheme for Wireless Sensor Network using Genetic Algorithm. *International Journal of Digital Application & Contemporary Research*. 2: 1–7.
- [6] I. Mahgoub and M. Ilyas. 2006. *Sensor Network Protocols*. CRC Press.
- [7] G. R. Mendez, M. A. M. Yunus, and S. C. Mukhopadhyay. 2011. A WiFi Based Smart Wireless Sensor Network For An Agricultural Environment. In *2011 Fifth International Conference on Sensing Technology (ICST)*, Palmerston North, New Zealand. 405–410.
- [8] G. R. Mendez, M. A. M. Yunus, and S. C. Mukhopadhyay. 2012. A WiFi Based Smart Wireless Sensor Network For Monitoring An Agricultural Environment. In *2012 IEEE International Instrumentation and Measurement Technology Conference (I2MTC)*, Graz, Austria, 2012, 2640–2645.
- [9] N. Wang, N. Zhang, and M. Wang. 2006. Wireless Sensors in Agriculture and Food Industry—Recent Development and Future Perspective. *Computers and Electronics in Agriculture*. 50: 1–14.
- [10] M. V. Ramesh. 2009. Real-Time Wireless Sensor Network for Landslide Detection. In *Third International Conference on Sensor Technologies and Applications, 2009. SENSORCOMM '09*, Athens/Glyfada, Greece, 405–409.
- [11] H. Z. Kotta, K. Rantelobo, S. Tena, and G. Klau. 2011. Wireless Sensor Network for Landslide Monitoring in Nusa Tenggara Timur. *TELKOMNIKA Indonesian Journal of Electrical Engineering*. 9: 9–18.
- [12] D. T. T. Chang, L. L. Guo, K. C. Yang, and Y. S. Tsai. 2011. Study of Wireless Sensor Network (WSN) using for Slope Stability Monitoring. In *2011 International Conference on Electric Technology and Civil Engineering (ICETCE)*, Lushan, China. 6877–6880.
- [13] D. Tarchi, N. Casaghi, R. Fantì, D. D. Leva, G. Luzi, A. Pasuto, et al. 2003. Landslide Monitoring by Using Ground-based SAR Interferometry: An Example of Application to the Tessina Landslide In Italy. *Engineering Geology*. 68: 15–30.

- [14] C. Amhardt, K. Asch, R. Azzam, R. Bill, T. M. Fernandez-Steeger, S. D. Homfeld, et al. 2007. Sensor based Landslide Early Warning System-SLEWS. Development of a Geoservice Infrastructure as Basis for Early Warning Systems for Landslides by Integration of Real-time Sensors. *Geotechnologien Science Report*. 10: 75–88.
- [15] J. A. Gili, J. Corominas, and J. Rius. 2000. Using Global Positioning System Techniques in Landslide Monitoring. *Engineering Geology*. 55: 167–192.
- [16] F. Ahmad, A. S. Yahaya, M. M. Ali, and S. H. A. Hairy. 2012. Qualitative Risk Assessment Schemes Using Selected Parameters for Hillslope Developments: A Case Study of Penang Island. *Landslides*. 9: 63–74, 2012/03/01.
- [17] R. Nagarajan, A. Mukherjee, A. Roy, and M. V. Khire. 1998. Technical Note Temporal Remote Sensing Data and GIS Application In Landslide hazard zonation of part of Western ghat, India. *International Journal of Remote Sensing*. 19: 573–585, 1998/01/01.
- [18] F. C. Dai, C. F. Lee, J. Li, and Z. W. Xu. 2001. Assessment of Landslide Susceptibility on the Natural Terrain of Lantau Island, Hong Kong. *Environmental Geology*. 40: 381–391.
- [19] R. F. M. Inc. 2010, 15 April. *WSN802G series 802.11g wireless sensor network modules integration guide*. Available: http://wireless.murata.com/datasheet?RFM/data/wsn802g_manual.pdf.
- [20] R. L. Ray and J. M. Jacobs. 2007. Relationships Among Remotely Sensed Soil Moisture, Precipitation and Landslide Events. *Natural Hazards*. 43: 211–222.
- [21] R. M. Iverson, M. E. Reid, and R. G. LaHusen. 1997. Debris-flow Mobilization From Landslides 1. *Annual Review of Earth and Planetary Sciences*. 25: 85–138.