

Hardware Development of Electrical Capacitance Tomography (ECT) System with Capacitance Sensor for Liquid Measurements

Chan Kok Seong^a, Jaysuman Pusppanathan^a, Ruzairi Abdul Rahim^{a*}, Goh Chiew Loon^a, Yvette Shaan-Li Susiapan^a, Fatin Aliah Phang^b, Mohd Hafiz Fazalul Rahiman^c

^aProcess Tomography and Instrumentation Engineering Research Group (PROTOM-i), Infocomm Research Alliance, Faculty of Electrical Engineering, Universiti Teknologi Malaysia, 81310 UTM Johor Bahru, Johor, Malaysia

^bCentre of Engineering Education (CEE), Universiti Teknologi Malaysia, 81310 UTM Johor Bahru, Johor, Malaysia

^cTomography Imaging Research Group, School of Mechatronic Engineering, Universiti Malaysia Perlis, 02600 Arau, Perlis, Malaysia

*Corresponding author: ruzairi@fke.utm.my

Article history

Received : 15 August 2014

Received in revised form :

5 January 2015

Accepted : 10 February 2015

Graphical abstract

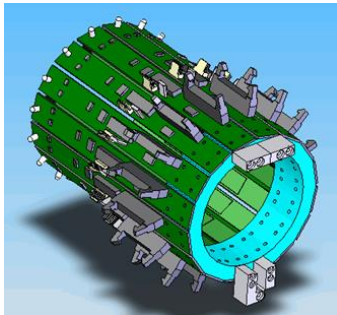

Abstract

Electrical capacitance tomography system is useful for obtaining information about the spatial distribution of a mixture of dielectric materials inside a vessel. This research aims to obtain real-time monitoring on the composition for liquid mixture in conveying pipeline. ECT is a non-invasive, non-intrusive and non-destructive technique that can measure the flow level inside a pipeline. In order to increase the image resolution and accuracy of current tomography research, a study on 16 electrodes sensor ECT system has been developed. The developed system has the flexibility to be assembled and moved from a pipeline to another. The intelligent on-board flexibility and mobility sensor technique is a new technique for ECT system. The system can be assembled in different diameter sizes of pipeline, and numbers of electrodes sensor can be reduced accordingly depending on the pipeline sizes without the need to redesign the electrodes sensor. The new design is equipped with high speed data processing rate data acquisition system and high speed data reconstruction. A microcontroller that support full-speed USB data transfer rate has been designed as the centralization control unit. In order to improve data result, iterative algorithm has been implemented in this system in order to obtain a precise image of the flow in the pipeline. As a result, the ECT system is able to reconstruct various multiphase flow images.

Keywords: Ultrasonic Transducer; tomography; ADC; multi-level pulser; operational amplifier

© 2015 Penerbit UTM Press. All rights reserved.

1.0 INTRODUCTION

Any two adjacent conductors can be considered as a capacitor, and different dielectric properties between the conductors will create different capacitor value. An ECT system is able to obtain information about the contents of vessels, based on measuring variations in the dielectric properties of the flowing material inside the vessel. ECT can be used with vessels of any cross-section, but most to-date work has used circular geometries [1].

An ECT sensor consists of a set of measurement electrodes mounted symmetrically inside or more typically outside an insulation pipe [2]. A typical ECT system consists of a sensor built up from 8, 12 or 16 electrodes, capacitance measurement circuit, central control unit and a control PC [3]. The electrode which is normally built from conductive plate acts as sensing surface that direct contact to the measuring area. The capacitance measuring circuit or better known as signal conditioning circuit is used to collect data and convert the measurement readings to digital. A central control unit is designed to synchronize all the operations and transfer the data to a control PC. A control PC

receives the measurements reading, store the acquired data, reconstruct images from the integral measurements and take action feedback to control the flow [4].

The signal conditioning system consists of several parts, such as capacitance measurement circuit, amplifying circuit, filter circuit and finally AC to DC converter circuit. Other than that, a high frequency sine wave generator is also required as the excitation source for the sensor electrodes. The electronic devices produce the output data and send to the data acquisition system for analog to digital conversion purpose. The digital data will be sent to computer for analysis and image reconstruction. The topology of an ECT system is shown in Figure 1.

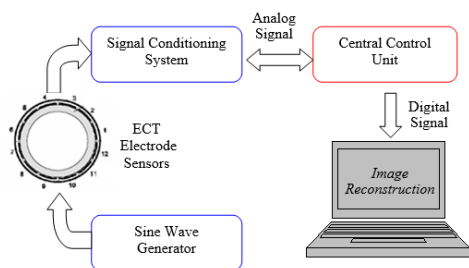

Figure 1 ECT system topology

2.0 FUNDAMENTALS OF ECT

The basic principle of ECT system is to measure the changes in capacitance from the multi-electrode sensor, and then reconstruct a permittivity distribution, (i.e. image) using the measured capacitance data. In these applications, the sensors usually consist of two electrode plates and the capacitance. The measurement is determined by:

$$C = \frac{\epsilon_0 \epsilon_r A}{d_p} \quad (1)$$

Where

C = capacitance (F)

ϵ_0 = permittivity of free space

ϵ_r = permittivity of the dielectric

A = area of the plate

d_p = the distance between those plates

The ϵ_0 and ϵ_r are the global average of the fluid dielectric property over the entire sensing volume of the sensor or better known as permittivity. If the area of the plate and the distance between them are known, by measuring the capacitance; the dielectric constant can be measured effectively. In this case, capacitance value is thus proportional to the permittivity in between the electrodes. In order to improve the signal-to-noise ratio (SNR) of the measurement, the sensing area of the electrodes can be increase [5].

The requirements for the tomographic imaging is that the sensors should facilitate multiple and localized measurement throughout the region of investigation. This implies that multiple electrodes should be arranged around the boundary of the inspected region and the capacitance between all the combination pairs of the electrodes should be measured in order to perform a 'body scan' of the imaging volume.

A complete cycle for an ECT system measurement is started with the first electrode (name as electrode 1), becomes the excitation electrode. When the electrode is supplied with a sine wave (which is referred to as the source electrode), all the other electrodes act as receivers receive the capacitor value correspond to the dielectric in between. For example, capacitances between electrodes 1 and 2, 1 and 3, 1 and 4 until 1 and the last electrode are measured, in parallel. During this measurement phase, electrodes other than electrode 1 are at the virtual earth potential imposed by the transducer and they are called the detecting electrode. After that, electrode 2 will take turn to be the source electrode and the rest electrodes act as detecting electrodes. The processes keep continuing until every electrode had become the source electrode, and now the complete cycle is done. The system screen and the projected guards are always maintained at earth

potential. The method of projection is also known as fan-beam projection

In general, for an N-electrode sensor ECT system, due to the overlapping capacitance, for example electrode 1 to electrode 2 and vice versa will have same capacitance value, the number of standalone independent capacitance measurements M is given by

$$M = \frac{N(N-1)}{2} \quad (2)$$

Where

M = Total capacitance measurements required for image reconstruction

N = Total electrodes sensor

By using some reconstruction algorithms, an image can be generated from the measurement of the data obtained. This image is the permittivity distribution at the cross-section defined by the electrode ring, which reflects the mixture component distribution. In general, the relationship between the measured inter-electrode capacitances and the permittivity distribution of dielectric materials is complex and non-linear [6]. For that reason, a suitable reconstruction algorithm is much needed in order to provide good quality images.

3.0 CAPACITANCE SENSOR DESIGN

An important step in planning a successful ECT application is the design of the capacitance sensor, as this is normally unique for different applications. The design of ECT sensors is closely linked to the capabilities of the capacitance measurement system. The structure of a primary sensor will no doubt influence the performance of a capacitance measurement system [7]. An ideal capacitance measuring system will have a very low noise level, a wide dynamic measurement range and high immunity to stray capacitance. Stray capacitance is a type of noises where the leakage capacitance due to connection from the circuit and cable to the electrode. To minimize the noises created by cable, a new technique, name as intergraded electrode sensor has been introduced in this research. The signal conditioning circuit is built on the electrode sensor becomes an ECT sensor module. This module not only reduces the noises, but also can work independently.

Typical ECT sensors must have a high level of mechanical stability, because any small movement between electrodes will change the values of inter-electrode capacitances. In the previous research in ECT so far, all the electrode sensors were built fixed on the vessel. The electrode plate cannot be moved to other vessel, and the installation must be done on the actual vessel. A new revolution of ECT system is introduced in this research, which the new generation in the ECT world, mobile or portable ECT system that can be load on any vessel in a second. Because of this feature, number of the electrode sensors can be selected depends on the diameter of the pipeline. Further information of the sensor will be discussed later in this paper.

Basically, an ECT sensor consists of multiple measurement electrodes mounted equally around the cross section of a process to be imaged, with an earthed screen outside the measurement electrodes [2]. An earthed screen is necessary to eliminate the external electrical interferences and to protect electrodes from damage [8]. The inter-electrode capacitances are typically fractions of a pico Farad and an earthed screen must be placed around the electrodes to eliminate the effects of extraneous signals and variations in the stray capacitance to earth, which would otherwise predominate and corrupt the measurements. The basic

configuration of an ECT sensor is shown in Figure 2. The space between the electrodes is filled with either gas or other insulating materials. This phenomenon would produce standing capacitance that will be measured for the use of image reconstruction.

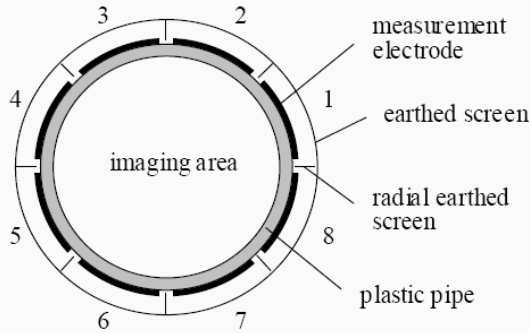

Figure 2 Cross sectional view of 8 measurement electrodes

3.1 Sensor Electrodes Design

The determination on the number of electrodes around the circumference of the pipeline is a tradeoff between axial and radial resolution, sensitivity and image capture rate. For example, the electrode surface area per unit axial length decreases and the inter-electrode capacitances also decrease as the number of electrodes increases. Standing capacitance, when the vessel contain a low-permittivity material, for adjacent electrodes have the largest values while diagonally opposing electrodes have the smallest standing capacitances [9]. When the smallest of these capacitances (for opposite electrodes) reaches the lowest value that can be measured reliably by the capacitance circuitry, the size of electrodes, and hence the image resolution, can only be increased further by increasing the axial lengths of the electrodes. However, these lengths cannot be increased indefinitely because the standing capacitances between pairs of adjacent electrodes will also increase and the measurement circuitry will saturate or overload once the highest capacitance measurement threshold is exceeded [1]. In this research, 16 electrodes have been fabricated onto the 110 mm diameter pipeline. The material of the electrode must be highly conductive material, such as copper, aluminum, silver, brass, tungsten or iron. Table 1 shows comparison between some high conductivity materials. Copper has been chosen because it can be found on any bare Printed Circuit Board (PCB). Despite the fact that the copper is a highly conductive material, which is desirable in an ECT system, the cost of this material is low and it is easy to be fabricated.

Table 1 Typical electrical conductivities

Conductor	Electrical Conductivity (S.m ⁻¹)	Temperature (°C)
Silver	63.01 x 10 ⁶	20
Copper	59.6 x 10 ⁶	20
Annealed Copper	58.0 x 10 ⁶	20
Aluminum	37.8 x 10 ⁶	20
Brass	25.6 x 10 ⁶	28

The simplest arrangement from a constructional viewpoint consist of a non-conducting section of pipe surrounded by an array of equally-spaced capacitance electrodes with an overall outer earthed screen as shown in Figure 2. Based on the concept, the modified electrode sensor for ECT is created, by using special design PCB, as shown in Figure 3. The sensor module is made by a double layer copper plated FR4 ($\epsilon_r = 4.6$) PCB with s of 1.6 mm thickness. The FR4 is a widely used stiffener for flexible PCB and it is cost efficient solution for high-end application involving impedance control and high frequency applications. Compare to the past design on ECT system, the new electrode sensor not longer be bended and stick on the pipe wall. If 16 electrode sensors are used, the electrodes are arranged symmetrically in hex decagon surrounding the pipeline.

Each electrode sensing has 15mm in width, and 100 mm in length area as shown in Figure 3. And there is a 0.254 mm clearance between the sensing area copper and driven guard. The earth screen covers the top layer surface and the FR4 material becomes the insulating layer.



Figure 3 A complete electrode sensor design

3.2 Driven Guard and Earth Screen

In an ideal ECT sensor, the electric field lines will be normal to the sensor axis. However, if the electrodes used are shorter compared to the diameter of the sensor, the electromagnetic field lines will spread out at the ends of the electrodes. This will have two consequences: First, the capacitance measured between electrodes will be reduced and hence the measurement sensitivity will also be reduced. Second, the axial resolution of the sensor will be degraded because of the axial spreading of the field lines at the end of the electrodes. The purpose of the guard electrodes is to maintain a parallel electric field pattern across the sensor in the inspection region, by preventing the electric field lines from spreading axially at the ends of the measuring electrodes. This improves both the axial resolution and the sensitivity of the sensor. Other than that, earthed guard electrode tracks are needed between adjacent measuring electrodes to reduce the standing capacitance between adjacent electrodes to avoid overloading or saturating the capacitance measuring system. In this research, the driven guard has been intergraded onto electrode sensor in order to prevent the electric field lines from spreading at the ends of the measuring electrodes. These driven guard electrodes will surround the circumference of the pipeline once all the 16 electrodes have been installed on pipeline. The length of the guard electrodes is 33 mm on the left, and 43 mm on the right, as shown in Figure 4. The measuring electrodes must be completely surrounded by an earthed, to ensure the obtained signals in the signal conditioning circuit are not influenced by the disturbance in the air. In this research, the earth screen is located on the top layer of the electrode PCB as shown in Figure 4.

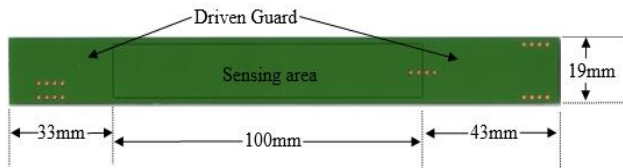

Figure 4 Electrode's dimension

3.3 Sensor Arrangement

Since the electrode PCB is kind of inelasticity, it creates an air gap between the sensing surface and pipe wall as shown in Figure 4. Due to the principal of image reconstruction technique, an ECT system only required to measure the changes of the dielectric material in between the electrodes, but not the actual capacitance value, thus the effect of small gap can be ignore if sensor is hold fixed on the pipeline. An assumption must be made as the distribution permittivity of air gap has no changes all the time, thus only the flowing material inside the pipeline will generate difference capacitance measurements. However, the sensitivity of the sensor is correlated to its axial length and signal bandwidth [12]. In order to increase the sensitivity, the axial length of sensor has to be at least the diameter size of the pipe and strong emitter signal in high frequency has to be used [13].

The placement of electrodes on the outer surface is done carefully to ensure that the electric field produced during the excitation is equally distributed among the detecting electrodes. Thus the circle (cross-section) of the pipeline is divided equally into sixteen sectors, which each sector is 22.5° as shown in Figure 5. The total width for one section is 21.88 mm. Each of the electrode PCBs has the dimension of 19 mm width, 180 mm length, and 1.6 mm thickness. The convention used to identify electrodes is to number them anticlockwise, starting at the electrode at or just before 3 o'clock [1]. So, for a 16 electrode sensor system, the electrode numbering can be referred to Figure 5.

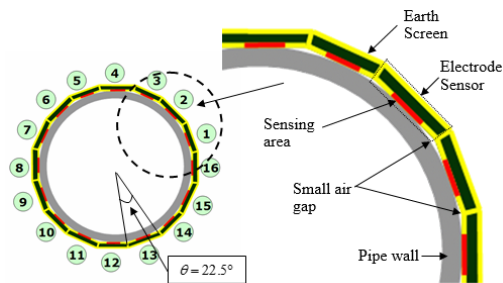

Figure 5 Electrodes arrangement of pipeline

3.4 Electrodes Connecting Techniques

In a practical ECT system, there are three main sources of stray capacitance which affect the capacitance measurement: screened cable, CMOS switches and sensor screen. A 1 m long screened cable is used to connect the sensing electrode to the measuring circuit, which introduced about 100pF of stray capacitance. Typically, the input capacitance of a CMOS switch that is used to select the electrode mode is 8pF. Besides, the sensor screen outside the sensing electrodes is unable to eliminate all the external noise, and thus contribute to the stray capacitance. The total stray capacitance is about 150pF, which is much larger than the measured capacitance. Additionally the stray capacitance may

vary with cable movement, ambient temperature changes, component variation and external or internal electric field changes.

In most of the previous research regarding ECT, the signals from the sensor electrodes are usually connected to the signal conditioning circuit by using coaxial cable. Coaxial cable is able to shield disturbance or stray capacitance and thus introduced a very low noise solution. However, the cable connecting the measuring electrode and signal conditioning circuit introduced the most stray capacitance. Therefore, this research introduces cable-less electrode design to avoid the stray capacitance. The electrodes are connected to the signal conditioning circuit directly without cable via connector socket which is soldered directly onto the electrode PCB board as in Figure 6. The solder lead is rubdown from the PCB to ensure the sensing area is flat during the fabrication on the pipe wall. Next, the electrode is directly connected to the measuring circuit with male part connectors as in Figure 7. Figure 8 shows the connection between the electrode and the measuring unit, with the total height of 10cm.

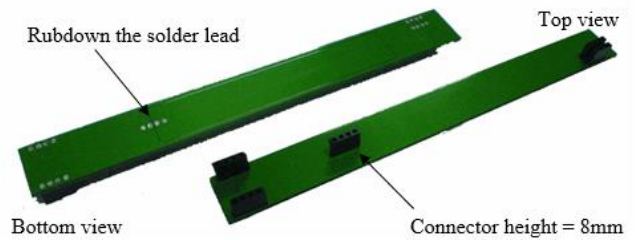

Figure 6 PCB Sockets for electrode mounting

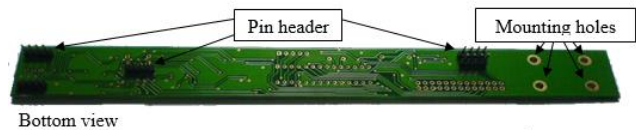

Figure 7 Measurement circuit with pin connectors

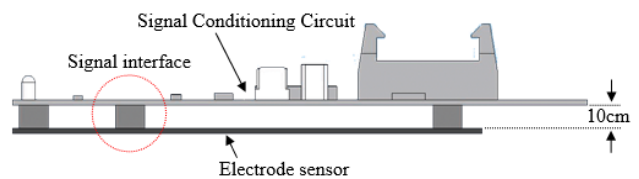

Figure 8 Electrode sensor and measuring circuit

4.0 SIGNAL CONDITIONING SYSTEM

Accurate data is only get with a good design in sensing electronics that able to eliminate noises. An important issue with instrumentation design is the performance of the circuit in the presence of noise, which is generated by external interference and thermal effects within components [10]. A suitable stray-immune circuit must be selected to satisfy this requirement. A stray-immune circuit measures only the capacitance between the selected pair of electrodes, and is insensitive to the stray capacitance between the selected, redundant electrodes and those between the selected electrodes and earth.

Each signal conditioning circuits is unique, and able to work independently because each measuring operations are controlled by a single microcontroller on each circuit. Each of the circuits consist of signal switching circuit, signal detection and amplifier circuit, absolute value circuit, low pass filter circuit, programmable gain amplifier (PGA), analog to digital converter

circuit and a microcontroller control unit. The desire sequence operation of electrode's signal selection, measuring data and conversion data is depended on programming in the microcontroller. The electrodes sensor are designed in a way that it can be plugged directly onto the PCB sockets of the signal conditioning circuit and becomes a single sensing module.

These sixteen boards are interconnected by using a 26 way IDC cable. This design had eliminated the need to use cables to connect the electrodes and signal conditioning circuits. Besides, this design is able to cut down the maintenance cost of the system. For example, if one sensing module is malfunctioning, users can simply change it by plugging out the board and replace it with a new board. Figure 9 shows the block diagram of a sensing module and the actual module is shown in Figure 10. Figure 11 shows the complete ECT signal conditioning system with 16 sensing modules.

In this research, the signal conditioning system will measure the capacitance produced by the electrode pairs when a 500 kHz sine wave voltage with the amplitude of $25V_{p-p}$ is injected to one of the electrode pair. With a 500 kHz excitation signal, the circuit has good linearity and stability. The determination of the transmitter and detector sequence is controlled by switching method and controlling unit. In the receiving electrodes, the signals will be conditioned through several stages, including the AC based capacitance measuring circuit, amplifier circuit, AC to DC converter circuit and filter circuit.

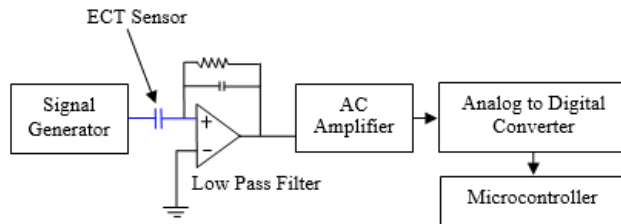

Figure 9 Sensing module block diagram

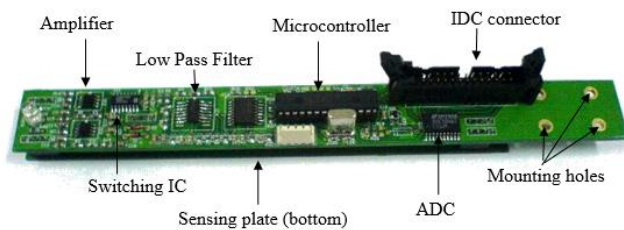

Figure 10 Actual sensing module

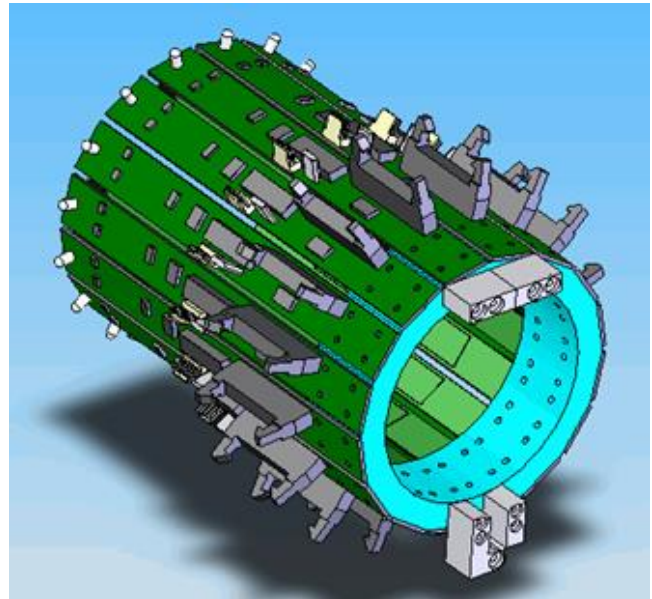

Figure 11 A complete ECT system

4.1 Signal Switching Circuit

In the sequence of the measuring operation, an electrode only can act as either source or detector. Thus, the signal switching is controlled by a switching circuit that formed by CMOS analog switches and controlled by microcontroller. The main function of this switching circuit is to control the switching sequence of the electrodes, which acts as source or detecting electrode. Each set of signal conditioning circuit needs a switching circuit. Thus, the configuration of the switching circuit in this ECT system is shown in Figure 12.

In the excitation mode, switches $S1$ and $S2$ are closed, while switches $S3$ and $S4$ are open. Hence the sine wave signal from the function generator can be flown to the electrode and the capacitance measuring circuit is disconnected from the electrode. In the detection mode, switches $S3$ and $S4$ are closed, while switches $S1$ and $S2$ are open. The switch $S3$ connects the coupling capacitance to earth and eliminating its effect on the inter-electrode capacitance measurement. However, due to the fact that switch coupling capacitance exist in CMOS analog switches, the signal from function generator is not totally separated from the electrode. This is where $S3$ takes an important role to flow the signal mentioned above to earth. Signal obtained from the electrode will be measured by the capacitance measuring circuit through $S4$.

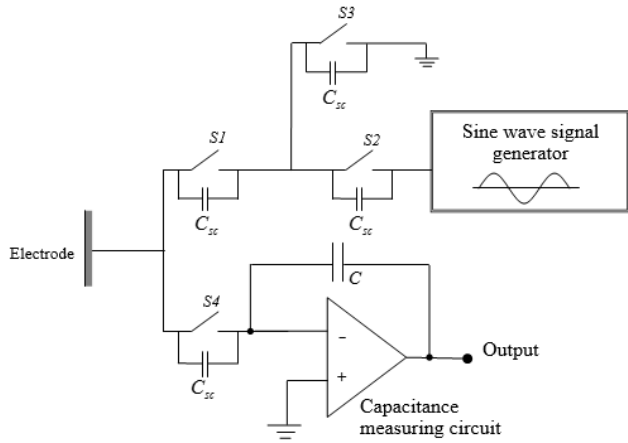

Figure 12 Signal switching block diagram

4.2 Detector and Amplifier Circuit

Stray-immune AC capacitance measuring circuit has been developed for ECT. AC-based capacitance measuring circuits using an operational amplifier (Op-amp) with resistor feedback, which directly measure the AC admittance of an unknown capacitance. In this research, the detector and ac amplifier circuit in used is shown in Figure 13.

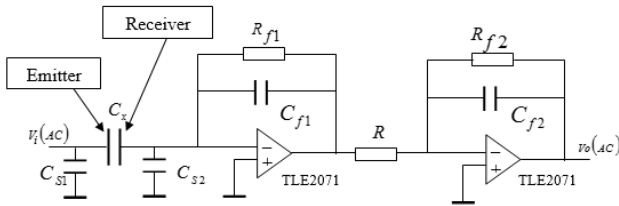

Figure 13 Block Diagram of detector and amplifier

From Figure 13, C_x is a standalone capacitance with unknown dielectric property in between the plates. Since C_{S1} is directly driven by the voltage source, it has no effect on the measurement of C_x provided that the output impedance of the voltage source is small enough. C_{S2} also has no effect on the measurement of C_x because the feedback point of the Op-amp is kept at virtual earth and there is no potential difference across C_{S2} . Therefore, this capacitance measuring circuit is inherently stray-immune. The excitation voltage V_i is applied to the unknown capacitance C_x . A wide bandwidth operational amplifier, with a feedback capacitance C_f and a feedback resistance R_f , convert the current into an AC voltage, V_o given by

$$V_o = -\frac{j\omega C_x R_f}{j\omega C_f R_f + 1} V_i \tag{3}$$

where ω is the angular frequency of the excitation voltage. When the capacitance feedback is selected to be dominant, i.e.

$$\frac{1}{\omega C_f} \ll R_f, \text{ equation (3) becomes:}$$

$$V_o = -\frac{C_x}{C_f} V_i \tag{4}$$

This AC signal is amplified further by an AC amplifier to accommodate a large range of capacitance values.

4.3 Absolute Value Circuit

The response of AC based detecting circuit is satisfactory and proven to be proportional to the standing capacitance measured through ECT electrode system, but AC signal output is unsuitable for further manipulation. To enable the signal to be directly interfaced with the microcontroller for data-sending to computer, AC to DC converter circuit is adapted. In fact, for faster response of the detected output, demodulation technique is the most suitable method. But due to its circuit complexity and higher cost, the AC to DC converter circuit is considered adequate. For this purpose, a few choices of circuit are available. Basically, the AC to DC converter circuit adapted is easily made absolute value circuit. Despite its simple circuitry, the outputs are considered fast among the available circuit. The other choices such as AC to DC precision converter circuit or the ready-made RMS to DC converter chip. Unfortunately, these circuits can only be applied on low frequency, normally from 50Hz to 1 kHz, and low duty-cycle pulse trains. Therefore, it is not suitable for use in this 500 kHz input frequency.

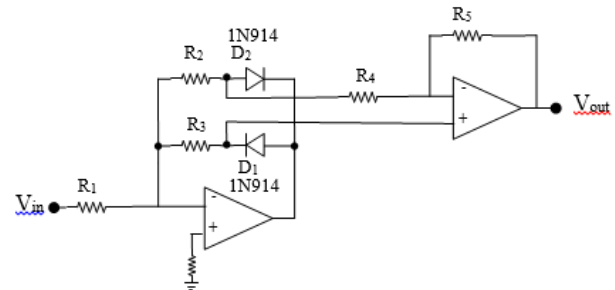

Figure 14 Absolute value circuit design

Absolute value circuit processes the output voltage to be equal to the input voltage without regard to polarity. As an example, a +3.3 Volts input and a -3.3 Volts input both produce the same (typically +3.3 Volts) output. The schematic diagram in Figure 14 shows the possible way. The first stage of this circuit is a dual half-wave rectifier. For a positive input signal, the output goes in a negative direction and forward-biases D_1 . This completes the feedback loop through R_2 . Additionally, the forward voltage drop of D_1 is essentially eliminated by the gain of the Op-Amp. That is, the voltage at the junction of R_2 and D_1 will be the same magnitude (but opposite polarity) as the input voltage.

When a negative input voltage is applied to the dual half-wave rectifier circuit, the output of the Op-Amp goes in a positive direction. This forward-biases D_2 thus completes the feedback loop through R_3 . Diode D_1 is reverse-biased. In the case of the basic dual half-wave rectifier circuits, the voltage at the junction of R_3 and D_2 is equal in magnitude (but opposite in polarity) to the

input voltage. In the case of the circuit in Figure 14, however, this voltage will be somewhat lower because of the loading effect of the current flowing through R_2 , R_4 and R_5 .

The outputs from the dual half-wave rectifier circuit are applied to the inputs of a differential amplifier circuit. Since the two half-wave signals are initially 180° out of phase and since only one of them gets inverted by amplifier A_2 , it can be concluded that the two signals appear at the output of A_2 with the same polarity. In other words, both polarities of input signal produce the same polarity of output signal. By definition, this is an absolute value function.

4.4 Low Pass Filter

A low pass filter circuit must be used to eliminate all the noises. As shown in the Figure 15, all resistor values are the same in the absolute value circuit, thus the calculations for design are fairly straightforward. All the parameters involved in this circuit are carefully considered and tested for the best performance. Generally, the circuit was designed according to the following goals:

- i. Input voltage approx. $-5.0V \leq V_{in} \leq 5.0V$
- ii. Input impedance $> 20\text{ k}\Omega$
- iii. Frequency range 350 kHz to 500 kHz

Slew rate and small signal bandwidth are investigated as the basis for Op Amp selection. The required unity gain frequency for A_2 can be computed with the equation as follow,

$$\begin{aligned}
 f_{unitygain} &= BW \times A_v = BW \left(\frac{R_5}{R_2 + R_4} + 1 \right) \\
 &= 500kHz \left(\frac{56k\Omega}{56k\Omega + 56k\Omega} + 1 \right) \\
 &= 750kHz
 \end{aligned}
 \tag{5}$$

The selection of resistance must be according to specific requirement. The minimum value for all of the resistors is determined by the required input impedance. The maximum value is limited by the non-ideal characteristics of the circuit, but is generally below $100\text{ k}\Omega$. The $56\text{ k}\Omega$ was chosen for the project design. Lastly, the absolute value circuit was combined with a first order low pass filter and the ripple signal was flattened using a capacitor. This arrangement is to reduce the noise and ensure true DC output from AC input voltage.

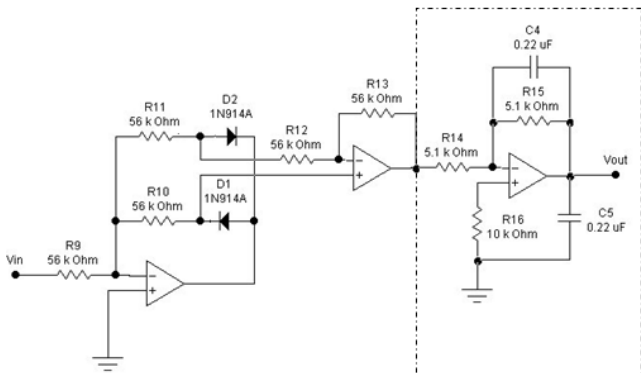

Figure 15 Low pass filter on absolute value circuit

4.5 Programmable Gain Amplifier (PGA)

A PGA is used to amplify the signal received with a controllable gain. It is a necessary to control the signal because the data received is in very large range. When one of the electrodes acts as emitter, all the rest electrodes will act as receiver. A receiver that's located nearest to the emitter will get a very large signal. In order to make sure the signal voltage is in measurable range, it must be amplified with a small gain. For the farthest opposite electrode pair, the receiver will receive a very small signal; hence a large gain must be applied to the signal.

A high speed programmable gain instrumentation amplifier, PGA206 IC has been applied in the system. The PGA206 has 4 gains selection, which are 1, 2, 4 and 8 V/V. It is digitally programmable and it is ideally suitable for data acquisition system. The gains are selected by two CMOS/TTL compatible lines, which mean it can be easily controlled by a microcontroller. The IC itself is laser-trimmed for low offset voltage and low drift.

4.6 Analog to Digital Converter (ADC)

Since all the outputs from the combination of the previous circuits are analog values, thus an ADC circuit must be applied to the final stage of the circuit before the signals are fed into microcontroller. An ADC10461 provided by National Semiconductor has been applied in this project. The ADC10461 is 10-Bit 600 nano seconds ADC with Input Multiplexer and Sample/Hold. The chip only needs a 5V supply, low power dissipation, no missing codes over temperature and no external clock required. In addition, the maximum sampling rate can achieve to 800 kHz.

4.7 Microcontroller

As mention earlier, each sensor module is unique, which can work independently. This is because all the operations on the module are controller by a single microcontroller control unit. A high performance CMOS FLASH 8 bit microcontroller, the PIC16F876 that provided by Microchip has been used in this research. The maximum microcontroller's operation speed is 20MHz and each instruction cycle is 200ns. The microcontroller synchronise all the operations on the sensing module. Generally, it has 3 main functions in the system: interfacing with central control unit, switching electrode sensor either act as source or receiver, controlling IC like PGA and ADC. A complete ECT sensor system in this research consists of 16 electrode sensor modules. Thus there are total 16 microcontrollers are linked together to a main controller, which is the central control unit. There are several type of communication methods available in microcontroller can be used, but in order to achieve the most highest speed, a special communication method has been create by using five digital channels. In order to identification the sensing module, each of the electrode sensors has its own pre-programmed address. The first digital channel control on source channel selection and the rest four digital channels assign the module's address. So that, an electrode will be selected if the last four channel state is matched its own address. For example, if all the last four channels are low state, the electrode at address 0000 is chosen.

The gain selection for PGA has been pre-programmed in every sensing module. Depend on the receiver electrode location; if the emitter electrode is located far away, the bigger gain is selected to amplify the signal. However, these data will then be normalized in software. The microcontroller keeps scanning the command changes on the data bus. If the first channel's state is high, and the address bus is matched to an electrode, the microcontroller on the module will receive the command and

control the sensing module to become an excitation electrode. At the same time, all the rest electrodes which are not been selected will process the measurement operations. The measurement operations consist of switch the electrode to become a detector electrode, apply gain to the signal before ADC, and do the conversion data on ADC. If the first channel's state is low, and any one of the sensing module match the address represent by the last four channels, then the central control unit now can read the 10 bits ADC data on the selected sensing module.

4.8 Function Generator

As mentioned earlier, the basic principle of electrical capacitance tomography system is revolved by exciting a sine wave at one of the electrode, and received by all the other electrodes. Therefore, a function generator has been developed in order to reduce the cost of the system. The function generator developed is able to produce sine wave, triangular wave and square wave. However, only sine wave generated will be used in this ECT system. This function generator can produce sine wave up to $29V_{p-p}$. The frequency of the sine wave generated can be varied from around 100 kHz up to about 1MHz. In the case of electrical capacitance tomography system's usage, sine wave with characteristic as above is sufficient.

In this system, a chip from Maxim, MAX038, is used. The MAX038 is a high frequency and precision function generator which produce triangle, saw tooth, sine, square, and pulse waveforms with a minimum of external components. The output frequency can be controlled over a frequency range of 0.1 Hz to 20M Hz by an internal 2.5V band gap voltage reference and an external resistor and capacitor. The output signal for all waveforms is a $2V_{p-p}$ signal that is symmetrical around ground. The output from the chip is fed into an amplifier circuit to produce a waveform of about $20V_{p-p}$. A suitable op-amp chip is selected. Slew rate and small signal bandwidth are investigated as the basis for op-amp selection. The required unity gain frequency for the op-amp can be computed with the equation as follow,

$$\begin{aligned} f_{\text{unitygain}} &= \text{Bandwidth} * \text{gain} \quad \dots (6) \\ &= 500 \text{ kHz} * 10 \\ &= 5 \text{ MHz} \end{aligned}$$

The required slew rate for the op-amp can be computed as follow,

$$\begin{aligned} \text{Slew rate} &= \pi * f * V_{o(\text{max})} \quad \dots (7) \\ &= \pi * 500 \text{ kHz} * 20V \\ &= 31.42 \text{ V/us} \end{aligned}$$

TLE 2082 is chosen as the amplifying op-amp in this function generator circuit. It has the bandwidth of 10 MHz and slew rate of 45 V/us, which is more than sufficient for the usage of this function generator circuit.

4.9 Function Generator Output

The function generator developed in this research is able to produce waveform from below 100 kHz to more than 1 MHz. This function generator can generate 3 types of waveform, which are sine wave, square wave and triangular wave. However, only sine wave is used in this research. Therefore, this section will only discuss the sine wave generated by the function generator developed. Figure 16 shows sine wave that is in used in this research. The function generator developed in this research is able to generate wave form from 87.93 kHz to 1.437 MHz. In fact, the function generator chip used in this research (MAX 038) is able to produce waveform from around 50 Hz to about 20 MHz. However, the circuitry of the function generator part in this research had restricted the chip to produce such a wide range of waveform frequency. Nevertheless, the frequency needed for this

ECT system will not exceed the limitation of the function generator developed. As mentioned by W. Q. Yang in year 1994, the capacitance measurement circuit has good linearity and stability with a 500 kHz excitation signal. This is the reason that 500 kHz sine wave is used as the excitation signal in this research.

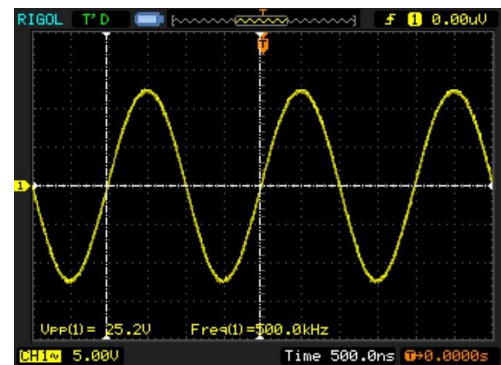

Figure 16 Function generator output

4.10 Central Control Unit

A central control unit is used to synchronize all the operation on collecting measurement data and sending the data to a PC for image reconstruction. A high performance and powerful microcontroller PIC18F4550 has been selected in the research, which is developed by Microchip. Thus, it can act as a standalone Data Acquisition System (DAS) that able to work independently. The PIC18F4550 has a built-in USB controller. The USB technologies supported by this chip are low speed and full speed USB. It means that the transfer rate of the hardware and PC can achieve a maximum of 1.5Mbps (low speed) or 12Mbps (full speed). This USB microcontroller uses a 24 MHz crystal, which working in about 167ns per instruction cycle. The collected data is sent to PC using Communication Device Class (CDC). This is a device level protocol specification defined by the USB association body. It defines the rules of how a USB host and a USB peripheral should communicate as a communication device. Specifically, the CDC specification defines a wrapper protocol layer around other communication protocols allowing them to be transported over the USB interface. A standardized specification also allows a USB host and a USB peripheral to be developed independently. In order to make the easiest way for this system to interface to a PC, implementation of RS-232 emulation over USB technique has been used. One of the most advantage by using this technique because the Windows 2000 and XP already come with a driver which provides the RS-232 emulation capability as defined in the CDC specification. The data received in PC will be received by the device driver, and then is retrieved through the software developed for further manipulation. Figure 17 is the picture of the central control unit of this research.

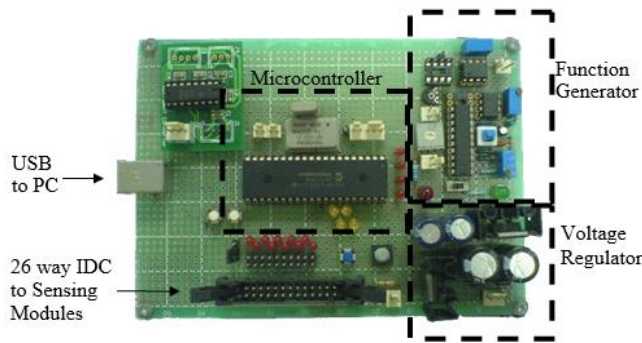

Figure 17 Data acquisition system

There are total of 120 data collected in each measurement cycle. And the data sending to PC in bulk will be much faster than sending in byte. Thus all the data will be stored in memory before send to PC for image reconstruction. The data received in PC will be received by the device driver, and then is retrieved through the software developed for further manipulation. Overall, the hardware is working standalone, which mean that the central control unit will take role to control the whole process after receive instruction from a host PC. The central control unit will keep controlling the measuring operation, collecting data from electrode modules and sending data to host computer for image reconstruction.

A new concept that every sensing module has its own microcontroller control unit has been applied. Thus the number of sensing module in used can be selected. The handling gripper can be designed based on diameter of the pipeline will be used. No any destructive will be made in order to install the sensing module. For this application a high excitation frequency is essential to achieve high sensitivity and fast data collection rates, and also to reduce the effect of any conductive component in parallel with the measured capacitance [2]. A function generator is designed and fabricated in order to reduce the cost and increase the flexibility of the system. This function generator is able to produce sine wave that satisfies the need of an ECT system.

In the past, industrial standard data acquisition cards are usually used as the data acquisition system in the ECT systems to simplify the design of the system. However, industrial standard data acquisition cards are rather expensive and there are a lot of functions in the cards that are not required in an ECT system. Therefore, a custom made data acquisition system had been designed in this research in order to reduce the cost of the system and increase the effectiveness of the system. The main function of the data acquisition system is to convert the analog signals from the signal conditioning circuit to digital data, and send the data to PC for analysis. In order to achieve real time system, fast analog to digital converter and fast data transfer protocol are needed. In this research, 16 ADC which are able to perform analog to digital conversion in 600ns are used. Each ADC is used to convert the signal from each electrode. The data converted are then sent to a microcontroller. The microcontroller will send the data to PC through USB technology after it collects one frame of data. Unlike other ECT system, no external function generator is needed. PC is used as a tool to display the results of the system in the form of tomogram, numerical value and graphs.

5.0 RESULTS AND DISCUSSIONS

Based on a pipeline with the diameter of 110mm and pipe wall 6mm, three types of two phase flow measurement experiments, which are water/air flow, water/oil flow and oil/air flow were conducted in this research. The concentration measurement method based on pixel value provides a more accurate reading than the concentration measurement method based on sensor value [11]. Thus the concentration measurement method based on pixel value will be analysis in this section. In the first part of the experiment, concentration of water is varied from 10 percent to 100 percent in a step size of 10 percent. The image reconstruction algorithm used is linear back projection algorithm. Figure 18 shows the real-time running program GUI for image reconstruction. The processing speed is 25 frames per second, which depends on the speed of computer processor. As shown in the picture, color tone represents density of water in the pipe. Density of water changes from low to high as the change of color follows the sequence: white, blue, red, green and black. For instance, 50% water, 50% air flow in the pipe produces a reconstructed image having white in half region and black in the other half region.

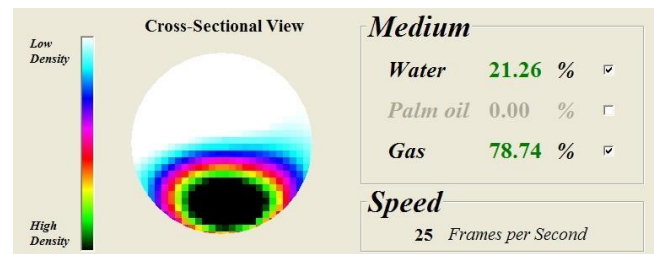

(a)

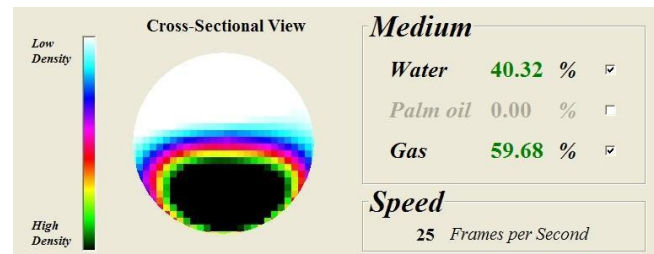

(b)

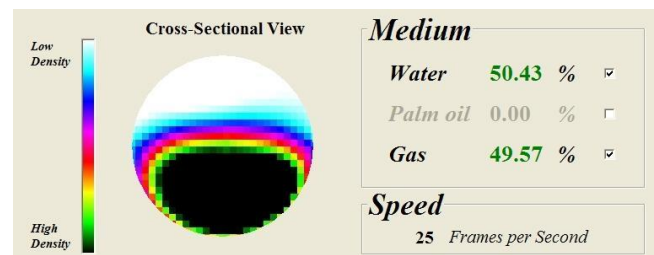

(c)

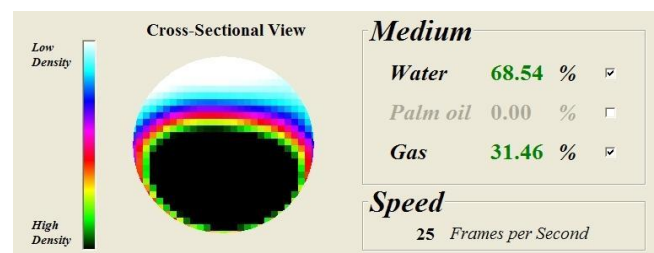

(d)

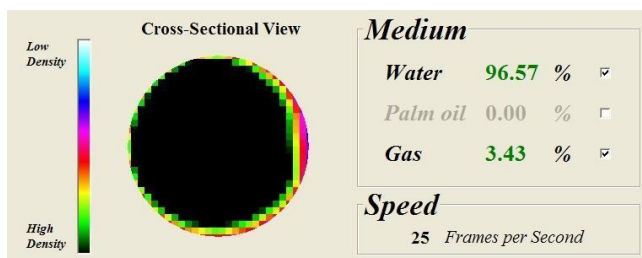

(e)

Figure 18 Two phase reconstructed Images of (a) 20% water, 80% air flow, (b) 40% water, 60% air flow, (c) 50% water, 50% air flow, (d) 70% water, 30% air flow and (e) 100% water, 0% air flow

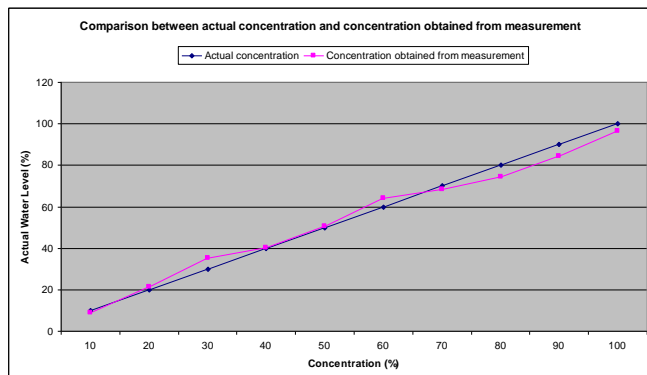

Figure 19 Comparison Between Actual versus Measured Concentration profile of Two Phase Flow

Figure 19 shows the comparison between actual concentration and concentration obtained from measurement for the water and air flow experiment. From Figure 19, concentration measured from the system and the actual concentration value has the same trend. The accuracy of the reconstructed image depends on two factors: temperature in the pipe and calibration method. When hardware surrounded the pipe is turned on, temperature in the pipe increase. Also, error may occur during calibration of normalized voltage. Increase of temperature and calibration error causes errors in the reconstructed image.

6.0 CONCLUSIONS

In this paper, the details on fabricating the sensors electrodes, designing the signal conditioning circuit, switching circuit and function generator circuit had been described. In short, a portable non-invasive sensor system is designed and fabricated, because there is no mechanical interaction between the fluid in the measurement plane and the electrodes. The system is designed so that it does not use cables to connect the electrodes and the signal conditioning circuit. This eliminates the cable noise. Other than that, stray immune capacitance measuring circuit design is implemented so that the circuit measures only the standing capacitance between the electrodes without affected by the stray capacitance in the circuit.

A new concept that every sensing module has its own microcontroller control unit has been applied. Thus the number of sensing module in used can be selected. The handling gripper can be designed based on diameter of the pipeline will be used. No any destructive will be made in order to install the sensing module. For this application a high excitation frequency is

essential to achieve high sensitivity and fast data collection rates, and also to reduce the effect of any conductive component in parallel with the measured capacitance. A function generator is designed and fabricated in order to reduce the cost and increase the flexibility of the system. This function generator is able to produce sine wave that satisfies the need of an ECT system.

Acknowledgement

The authors are grateful to the Research Management Centre, Universiti Teknologi Malaysia and for study support from a Research University Grant of UniversitiTeknologi Malaysia (Grant No. Q.J130000.2513.02H67).

References

- [1] Malcolm Byars. 2001. *Developments in Electrical Capacitance Tomography*. PTL Application Notes.
- [2] Yang, W. Q., Spink, D. M., Gamio, J. C. and Beck, M. S. 1997. Sensitivity Distributions of Capacitance Tomography Sensors with Parallel Field Excitation. *Meas. Sci. Technol.* 8: 562–569.
- [3] Qussai Marashdeh, Warsito Warsito, Liang-Shih Fan, and Fernando L. Teixeira. A Multimodal Tomography System Based on ECT Sensors. *IEEE Sensors Journal*. 7(3): 426–433.
- [4] Tong Zhaoa, Masahiro Takeia, Kenta Masakia, Ryoji Ogiso, Koji Nakao, Akira Uchiura. 2007. Sensor Design and Image Accuracy for Application of Capacitance CT to the Petroleum Refinery Process. *Flow Measurement and Instrumentation Journal*. 18: 268–276.
- [5] A. Martínez Olmos, M. A. Carvajal, D. P. Morales, A. García, A. J. Palma. 2008. Development of an Electrical Capacitance Tomography System Using Four Rotating Electrodes. *Sensors and Actuators A*. 148 366–375.
- [6] Yang, W. Q., Spink, D. M., York, T. A. and McCann, H. 1999. An Image Reconstruction Algorithm Based on Landweber's Iteration Method for Electrical Capacitance Tomography. *Meas. Sci. Technol.* 10: 1065–1069.
- [7] Xie, C. G., Huang, S. M., Hoyle, B. S., Lenn, C., Snowden, D., and Beck, M. S. 1992. Electrical Capacitance Tomography for Flow Imaging: System Model for Development of Image Reconstruction Algorithms and Design of Primary Sensors. *IEE Proceedings-G*. 139.
- [8] Tan Chee Wei. 2003. *Measurement of Two-Phase Imaging (Water/Gas Bubbles) By Using Electrical Capacitance Tomography (ECT)*. Universiti Teknologi Malaysia: B.Sc. Thesis.
- [9] Javad Frounchi, Ali-Reza Bazzazi, Khabat Ebnabbasi and Kaveh Hosseini. 2003. *High Speed Capacitance Measuring System for Process Tomography*. 3rd World Congress on Industrial Process Tomography, Banff, Canada.
- [10] Philip Williams and Trevor York. 1999. *Evaluation of Integrated Electrodes for Electrical Capacitance Tomography*. 1st World Congress on Industrial Process Tomography, Buxton, Greater Manchester, April 14–17, 1999.
- [11] Tee, Z. C., Abdul Rahim, R., Chan, K. S., Electrical Capacitance Tomography Using Universal Serial Bus Technology, 3rd International Symposium on Process Tomography, Lodz, Poland 9–10 September 2004.
- [12] Yang Daoye, Zhou Bin, Xu Chuanlong, Tang Guanghua, Wang Shimin. 2009. Effect of Pipeline Thickness on Electrical Capacitance Tomography. *Journal of Physics: Conference Series*. 147.
- [13] J. Puspanathan, et al. 2013. Study on Single Plane Ultrasonic and Electrical Capacitance Sensor for Process Tomography System. *Sensors & Transducers*. 150(3): 40–45.
- [14] M. J. Puspanathan, F. R. Yunus, N. M. Nor Ayob, R. Abdul Rahim, F. A. Phang, H. Abdul Rahim, P.L. Leow, K. H. Abas. September 2013. A Novel Electrical Capacitance Sensor Design For Dual Modality Tomography Multiphase Measurement. *Jurnal Teknologi (Special Edition) (ISSN 2180-3722)*. 64(5): 45–47. doi 10.11113/jt.v64.2130.
- [15] Shahrulnizahani Mohammad Din, Aizat Azmi, Chee Pei Song, Ruzairi Abdul Rahim, Leow Pei Ling. July 2014. Electric Potential of Various 4-electrode Segmentation Excitation for Electrical Capacitance Tomography System. *Jurnal Teknologi-Special Issue on Advanced Measurement and Sensor*. 69(8): 35–38. eISSN 2180-3722.