

ANFIS Modelling of Carbon and Nitrogen Removal in Domestic Wastewater Treatment Plant

Muhammad Sani Gaya^a, N. Abdul Wahab^{a*}, Y. M. Sam^a, Sahratul Izah Samsudin^b

^aControl and Mechatronics Engineering Department, Universiti Teknologi Malaysia, 81310 UTM Johor Bahru, Johor, Malaysia

^bFaculty of Electronics and Computer Engineering, Universiti Teknikal Malaysia Melaka, Ayer Keroh, Melaka, Malaysia

*Corresponding author: aliza@fke.utm.my

Article history

Received :5 August 2013

Received in revised form :

28 November 2013

Accepted :15 January 2014

Graphical abstract

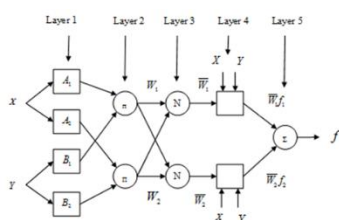

Abstract

Wastewater treatment plant involves highly complex and uncertain processes, which are quite difficult to forecast. However, smooth and efficient operation of the treatment plant depends on an appropriate model capable of describing accurately the dynamic nature of the system. Most of the existing models were applied to industrial wastewater treatment plants. Therefore, this paper proposed an ANFIS model for carbon and nitrogen removal in the Bunus regional sewage wastewater treatment plant, Kuala Lumpur, Malaysia. For comparison, feed-forward neural network is used. Simulation results revealed that the ANFIS model demonstrated slightly better prediction capability in all the considered variables, chemical oxygen demand (COD), suspended solids (SS) and ammonium nitrogen (NH₄-N) as compared to the FFNN model, thus proving that the proposed ANFIS model is reliable and useful to the wastewater treatment plant.

Keywords: Prediction; fuzzy inference system; neural network; parameters

Abstrak

Loji rawatan sisa air melibatkan proses yang rumit dan sukar diramalkan. Walau bagaimanapun, kelincinan dan kecekapan operasi dan rawatan loji bergantung kepada kesesuaian model yang menghuraikan sistem dinamik yang tepat. Kebanyakan model yang sedia ada diguna pakai oleh kebanyakan industri. Dengan itu, kertas kerja ini mencipta satu model ANFIS untuk pembuangan sisa karbon dan nitrogen bagi loji rawatan sisa di Bunus, Kuala Lumpur, Malaysia. Sebagai perbandingan, suap-depan rangkaian neural digunakan. Daripada keputusan simulasi, model ANFIS menunjukkan keputusan ramalan yang amat menggalakkan bagi semua pemboleh ubah seperti *chemical oxygen demand* (COD), *suspended solids* (SS), dan ammonium nitrogen (NH₄-N) dibandingkan dengan model FFNN yang mana membuktikan model ANFIS yang dicadangkan adalah lebih stabil dan berguna untuk loji rawatan lembah sisa.

Kata kunci: Ramalan; sistem beralasan kabur; rangkaian neural; parameter

© 2014 Penerbit UTM Press. All rights reserved.

1.0 INTRODUCTION

The dynamic nature of wastewater treatment plant involves several complex and nonlinear processes, which are quite hard to predict. However, suitable model plays a crucial role in describing the intricate biological/biochemical reactions and interactions taking place in the system. Application of control strategy or optimization technique in order to increase the efficiency of the plant for organic carbon and nitrogen removal relies upon an accurate model.

Literature reveals that several models were developed for wastewater treatment process, for instance, activated sludge models (ASMs) family (ASM1, ASM2, ASM2D, and ASM3) which have proven to be indispensable tools within last decades, made a remarkable impact in achieving reliable treatment plant design, better understanding of system mechanisms and more importantly serves as guidance for research [1], especially the state of art model (ASM1) for carbon and nitrogen removal. Based on this mathematical model concept various models either

practically or via simulation were developed [2], [3], [4], [5], [6], [7], [8]. Nevertheless, most of these developed models were either applied to completely mixed tank or contact stabilization and industrial wastewater treatment plant.

Therefore, it is the objective of this paper to investigate the effectiveness of ANFIS modelling approach for organic carbon and nitrogen removal in step feed domestic wastewater treatment plant. Neuro-fuzzy approach evolved from integration of neural network and fuzzy system, which creates an effective tool for solving complex real-world problems. One of the most commonly used neuro-fuzzy systems is an adaptive neuro-fuzzy inference system (ANFIS) due to its ability to endure imprecisions, uncertainties and handling of large rowdy data set. ANFIS train the parameters of the fuzzy inference system through learning algorithm deduced from neural network [9]. Considering the difficulties associated with the conventional or analytical approaches and the experimentation/computational cost, ANFIS techniques are suitable choices to predict the carbon and nitrogen removal in the system. In this study, ANFIS method

was proposed to model carbon and nitrogen in the plant using the variables such as, chemical oxygen demand (COD), suspended solids (SS) and ammonium nitrogen (NH₄-N). These variables are chosen, since they are among the parameters by which the strength of wastewater is measured. Feed-forward neural network was employed in order to compare the accuracy of prediction.

2.0 EXPERIMENTAL WORK

2.1 The Plant Description

The raw (influent) wastewater from Semarak and Setapak pump stations entered the plant. The grits contained in the influent wastewater are removed in the grit chamber to avoid causing damage on the system. Large percentage of biological oxygen demand (BOD), COD, SS and other pollutants are removed during the primary treatment. The effluent from the primary settler flows to the secondary treatment unit which consists of aeration tanks and secondary settler as shown in Figure 1. In the aeration tanks, favourable condition is provided for the microorganisms responsible for degrading the remaining dissolved organic pollutants in the wastewater to grow and form sludge. The sludge is separated from the treated water in the secondary settler by gravity sedimentation. A portion of the sludge is returned to the aeration unit to maintain the microorganisms' concentration, and the waste sludge is removed and transferred to the sludge treatment facility. A suitable model could be useful in application of control strategy or optimization technique to the plant in order to increase the treatment efficiency and reduce energy consumption.

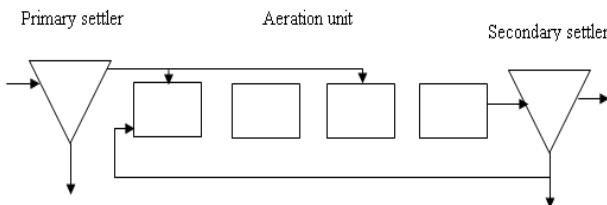

Figure 1 Schematic activated sludge process of the plant

2.2 ANFIS Method

The integration of neural network with the fuzzy system creates a robust hybrid system capable of solving complex problems. The behaviour of this hybrid system can be described in a similar manner to human rules, thus making the system an accurate tool for approximating non-linear functions [10]. ANFIS uses a hybrid learning algorithm which defines how the weights should be updated to reduce error between the actual and desired output which in turn adjusts the parameters and the structure of the fuzzy inference system (FIS). The structure of ANFIS is shown in Figure 2, which is a Sugeno fuzzy model.

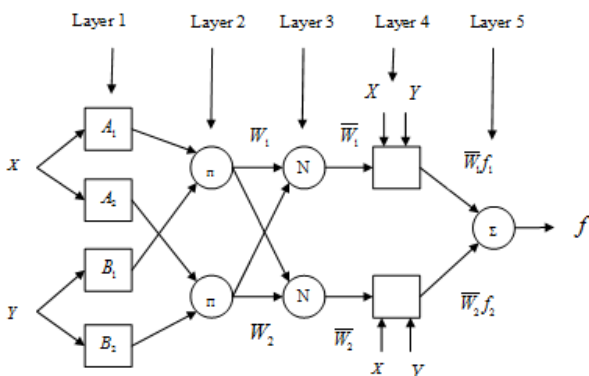

Figure 2 ANFIS structure

For illustration, assume that the FIS has two inputs *x* and *y* and a single output *f*. For first-order Sugeno model, a typical rule set with two fuzzy "if-then rules" can be as follows:

Rule 1: if *x* is A₁ and *y* is B₁, then *f*₁ = *p*₁*x* + *q*₁*y* + *r*₁

Rule 2: if *x* is A₂ and *y* is B₂, then *f*₂ = *p*₂*x* + *q*₂*y* + *r*₂

where A_{*i*}, B_{*i*} are the membership functions of the inputs and *p*_{*i*}, *q*_{*i*}, *r*_{*i*} are parameters to be optimized during the learning process. It can be seen from Fig. 2, the ANFIS consists of layers and nodes. The square nodes are referred as adaptive containing parameters in them whereas the circular nodes are fixed. The functions of the layers are:

Layer 1: In this layer, every node *i* is an adaptive node having a node function

$$O_i^1 = \mu_{A_i}(x), \text{ for } i=1,2 \tag{1}$$

Or

$$O_i = \mu_{B_{i-2}}(y), \text{ for } i=3,4 \tag{2}$$

where *O*_{*i*} is the membership grade for input *x* or *y*. The membership function could be anything. The available membership functions were tested using the training data samples as illustrated in Table 1, but Gaussian was chosen as a result of having the lowest prediction error. Gaussian membership is expressed as:

$$\mu_{A_i}(x) = e^{-\frac{1}{2} \left(\frac{x-c_i}{\beta_i} \right)^2} \tag{3}$$

where *c*_{*i*} and *β*_{*i*} are the premise parameters to be optimized using gradient descent.

Table 1 Selection of membership function

Membership function	Prediction root mean square error
Triangular	0.0284267
Trapezoidal	0.0363495
Gbell	0.0208391
Gaussian	0.0188513
Gaussian	0.0321543

Layer 2: Every node in this layer is fixed node, which multiplies the incoming signal and sends the product out given by.

$$O_i^2 = w_i = \mu_{A_i}(x) \mu_{B_i}(y), \text{ } i=1,2 \tag{4}$$

Layer 3: This layer contained circular nodes, which compute the ratio of the firing strengths of the rules.

$$O_i^3 = \bar{w}_i = \frac{w_i}{w_1 + w_2} \tag{5}$$

Layer 4: Every node *i* in this layer is an adaptive node and performs the consequent of the rules.

$$O_i^4 = \bar{w}_i f_i = \bar{w}_i (p_i x + q_i y + r_i) \tag{6}$$

The parameters *p*_{*i*}, *q*_{*i*}, *r*_{*i*} are consequent parameters to be determined.

Layer 5: The single node in this layer computes the overall output

$$O_i^5 = \sum_i \bar{w}_i f_i = \frac{\sum_i w_i f_i}{\sum_i w_i} \tag{7}$$

The ANFIS uses a hybrid learning algorithm which is based on a combination of gradient descent and least square to optimize the parameters in the layer 1 and 4 of the network [9], [11]. In the forward pass, the input vector is forwarded and propagated

through the network layer by layer and the consequent parameters are updated by applying the least square method. As the values of premise parameters are held fixed, the overall output [11], [12] is given by.

$$\begin{aligned} f &= \frac{w_1}{w_1 + w_2} f_1 + \frac{w_2}{w_1 + w_2} f_2 \\ &= \overline{w_1} f_1 + \overline{w_2} f_2 \\ &= (\overline{w_1} x) p_1 + (\overline{w_1} y) q_1 + (\overline{w_1}) r_1 + (\overline{w_2} x) p_2 + (\overline{w_2} y) q_2 + (\overline{w_2}) r_2 \end{aligned} \quad (8)$$

where p_i , q_i and r_i are the consequent parameters

$$f = XW \quad (9)$$

For invertible X matrix

$$W = X^{-1} f \quad (10)$$

Otherwise, pseudo-inverse is applied to obtain W

$$W = (X^T X)^{-1} X^T f \quad (11)$$

In the backward pass, the error propagates backward through the network and the premise parameters (c_i and β_i) are optimised by gradient descent.

$$a_{ij}(t+1) = a_{ij}(t) - \frac{\eta}{p} * \frac{\partial E}{\partial a_{ij}} \quad (12)$$

where t is the learning epoch, η is the learning rate for a_{ij} and p is the number of input patterns.

The parameters are updated using the expression

$$\frac{\partial E}{\partial a_{ij}} = \frac{\partial E}{\partial f} * \frac{\partial f}{\partial c_i} * \frac{\partial c_i}{\partial w_i} * \frac{\partial w_i}{\partial \mu_{ij}} * \frac{\partial \mu_{ij}}{\partial a_{ij}} \quad (13)$$

The function is expressed as

$$E = \frac{1}{2} (f - f^t)^2, \text{ so } \frac{\partial E}{\partial f} = (f - f^t) = e \quad (14)$$

where f^t is the expected output and f depicts the fuzzy system output.

$$f = \sum_{i=1}^n f_i, \text{ considering } \frac{\partial f}{\partial f_i} = 1 \quad (15)$$

$$f_i = \frac{w_i}{\sum_{i=1}^n w_i} (p_i x + q_i y + r_i), \text{ so, } \frac{\partial f_i}{\partial w_i} = \frac{(p_i x + q_i y + r_i) - f}{\sum_{i=1}^n w_i} \quad (16)$$

$$w_i = \prod_{j=1}^m \mu_{A_j}, \text{ therefore } \frac{\partial w_i}{\partial \mu_{ij}} = \frac{w_i}{\mu_{ij}} \quad (17)$$

Hence, the gradient can now be expressed as:

$$\frac{\partial E}{\partial a_{ij}} = e \frac{(p_i x + q_i y + r_i) - f}{\sum_{i=1}^n w_i} \frac{w_i}{\mu_{A_j}} \frac{\partial \mu_{A_j}}{\partial a_{ij}} \quad (18)$$

Or

$$\frac{\partial E}{\partial b_{ij}} = e \frac{(p_i x + q_i y + r_i) - f}{\sum_{i=1}^n w_i} \frac{w_i}{\mu_{B_j}} \frac{\partial \mu_{B_j}}{\partial b_{ij}} \quad (19)$$

Based on this learning procedure, ANFIS maps input - output of the system. Once the parameter sets of the model are

acquired, the values of the model output is determined for every pair of the training data and compare with the measured values, thus the error between the actual and measured is evaluated. The model is achieved after the stopping criterion is met.

2.2.1 ANFIS Implementation

The training data can significantly affect the learning capability of the network; therefore, the data need to be converted into appropriate form for the network. The full scale data from the plant (7/01/2008-19/4/2011) were normalized between 0 and 1 using:

$$X(i) = \frac{x(i) - \min(s)}{\max(s) - \min(s)} \quad (20)$$

Where $X(i)$ depicts the normalized value of a sample, x_i is the sample value, $\min(s)$ is the minimum value in the data samples and $\max(s)$ is the maximum value in the data samples.

The normalized data pairs were divided into 70% for training and the remaining 30% for validation of the models (both ANFIS and FFNN), the selection of these data was done arbitrarily for the one day ahead prediction. Using the available fuzzy toolbox of the Matlab 7.1 software, the function ‘genfis1’ was applied to generate a first-order Sugeno fuzzy inference system (FIS) using grid partition on the data. The grid partition splits the data space based on the number of membership functions. Four (4) Gaussian membership functions were assigned to each input, which resulted into 1024 rules and each rule generates one rule output. The aggregate of the rule outputs yielded the final output. The input and output training data sets were shown in Table 2.

Table 2 Input-Output training data sets

Input (influent) Variable	Output (effluent) Variable
BOD	COD
COD	
SS	SS
NH ₄ -N	
O & G	NH ₄ -N

2.3 Neural Network

Neural network is a network of an interconnected group of neurons designed based on a mathematical model to process information. The interconnection strength (weight) is an important factor in determining the function of the network. Neural network comprises of nodes and links. The nodes receive the input signals, process the signals and yield an output. The links indicate the direction of information flow, which can be in only one direction or bidirectional depending upon the structure of the network. When the flow is unidirectional, the NN is termed as feed-forward. Feedback NN has feedback connections, which help them to learn the temporal behavior of the training data set [13]. Feed-forward neural network (FFNN) is the most widely used for input-output mapping of a linear or nonlinear function. The neural network (NN) training involves updating the weights (parameters) using an input-output data of the system to be modeled through learning algorithm such that the NN output is an accurate approximation of the system's output. The training can be a supervised or unsupervised depending upon the network. In supervised training, the inputs and the desired outputs are introduced to the NN. The responses (outputs) of the NN to the given inputs are measured. The parameters are updated by learning principle (algorithm) to minimize the (error) between the actual and the desired output. The learning principle is deduced by implementing a certain optimization method to a

given error measure [12]. However, for unsupervised training only inputs are provided, the parameters are adjusted so that the inputs yield the outputs. In both cases, sufficient training data set, which comprises of high and low values of the system are required in order to realize an accurate model and many training epochs.

Back propagation learning algorithm is used to train multi-layered feed-forward neural network. The network as shown in Figure 3 consists of neurons, which are organized into layers, having first layer as input and the last as an output layer. In between these layers there exist a number of hidden layers. During the training process, input signal is send forward and the errors are propagated backwards, and the weights are optimized. This kind of training is referred as sequential training. In batch training, the weights (parameters) are optimized after the whole training data are introduced into the network [14]. In both cases, the objective is to minimize error so that the network learns the training data.

For the error to be minimized, the weight need to be updated, therefore, as the input signal is sent through the network to the output [15], the error e_p on a single neuron p can be expressed as:

$$e_p = y_d - y_a \tag{21}$$

where y_d is the desired output of the neuron p and y_a is the actual output.

The obtained value of error is used to determine δ_p value as:

$$\delta_p = e_p g'(y_p) \tag{22}$$

where g' depicts the derived activation function. Since δ_p is obtained, the δ_j in the preceding layers can be determined:

$$\delta_j = \eta g'(y_j) \sum_{p=0}^N \delta_p w_{jp} \tag{23}$$

where N is the number of neurons is, η is the learning rate.

The weight update is given by

$$w_{jp} = w_{jp} + \Delta w_{jp} \tag{24}$$

The learning algorithm continues with the next input and updates the weight based on the output. The process repeats until the stopping criterion is met. However, it is important to choose an appropriate network structure because the learning capability and performance of the neural network relies on a suitable structure. Although, usually the structure is selected through trial and error, but care has to be taken in selecting the number of neurons in the hidden layer. Too many neurons in the hidden layer may affect the generalization ability of the neural network and increase computational burden, whereas too low neurons may not produce the required prediction accuracy.

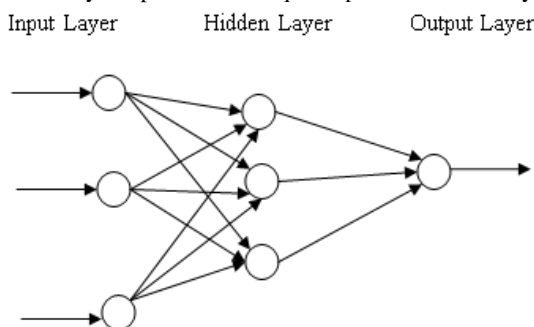

Figure 3 Feed-forward neural network structure

2.3.1 Neural Network Implementation

The structure of the network is formed through trial and error with ten neurons in the single hidden layer, since there is no simplified method to determine the number of the hidden nodes. However, consideration was made regarding the relationship between the number of neurons and training data sample as proposed [16] to avoid over-fitting of the training data:

$$N^\phi \leq \frac{N^\psi}{(N^\sigma + 1)} \tag{25}$$

where N^ϕ is the number of the neurons, N^σ is the number of input variables and N^ψ is the number training data samples. Using the neural network toolbox of the Matlab 7.1 software, the TRAINLM training function, tag-sigmoid (TANSIG) transfer function in the hidden layer and PURELIN in the output layer were chosen. The parameters (weights) of the FFNN are tuned through learning rule (back propagation) to minimize the means square error between the FFNN output and the target. The network is trained to realize the desired model. The use of checking data in all the models is to avoid the models from over fitting.

The performances of the ANFIS and FFNN models were evaluated through simulation based on the root mean square error (RMSE), mean absolute percentage deviation (MAPD) and correlation coefficient as given by the following expression:

$$RMSE = \sqrt{\frac{\sum (x_i - y_i)^2}{N}} \tag{26}$$

$$MAPD = \frac{\sum |x_i - y_i|}{\sum x_i} \tag{27}$$

$$R = \frac{n \sum xy - (\sum x)(\sum y)}{\left(\sqrt{n(\sum x^2) - (\sum x)^2} \right) \left(\sqrt{n(\sum y^2) - (\sum y)^2} \right)} \tag{28}$$

where x_i is the measured value, y_i is the predicted value and N refer to the number of samples.

3.0 RESULTS AND DISCUSSION

3.1 Model Prediction

The concentration of raw wastewater (influent) flowing into the treatment plant varies over time due to the human activity. Figure 4 illustrates the concentration of the influent COD, SS and NH4-N as the considered variables. For quality of the environment and health, it is necessary to reduce as low as possible the concentrations of these influent variables.

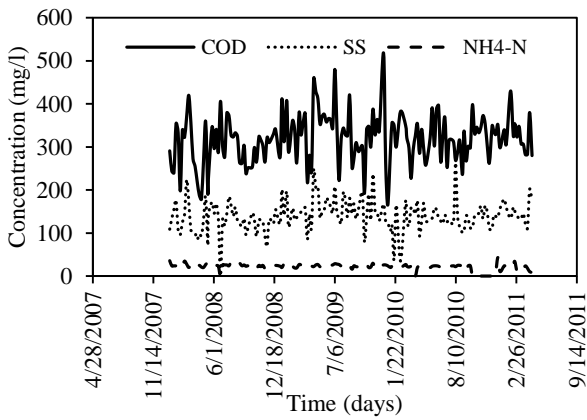

Figure 4 Influent (COD,SS & NH₄-N) concentrations

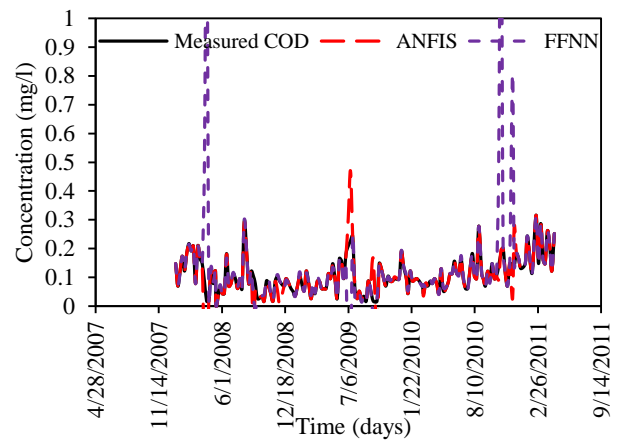

Figure 5b Validation performance for effluent COD prediction

The measures equations 25 to 27 were employed since the accuracies of the models are to be compared in term of predicting the effluent COD, SS and NH₄-N variables. The results obtained for these variables are presented in Table 3.

Table 3 Prediction performance

Variable	Model	Training			Validation		
		RMS E	MAP D	R	RMS E	MAP D	R
COD	ANFI S	0.0026	1.283	0.999	0.0441	10.597	0.847
	FFN N	0.0076	3.701	0.992	0.1914	13.601	0.647
	ANFI S	2E-05	0.004	1	0.0069	5.365	0.995
SS	FFN N	0.0013	2.06	0.999	0.6449	16.932	0.512
	ANFI S	0.0014	0.701	0.999	0.0333	11.393	0.948
NH ₄ -N	FFN N	0.0026	1.88	0.998	0.3677	18.655	0.425

3.1.1 Effluent COD Prediction

Figure 5a shows the ANFIS and FFNN predictions for the COD variable. During the training both models have demonstrate good agreement with the measured COD, however, ANFIS results were slightly better than that of FFNN. In validation phase as shown in Figure 5b, it is apparent that the ANFIS exhibited high prediction capability than FFNN due to many prediction errors, which led the model to have RMSE 0.1914 as in Table 3.

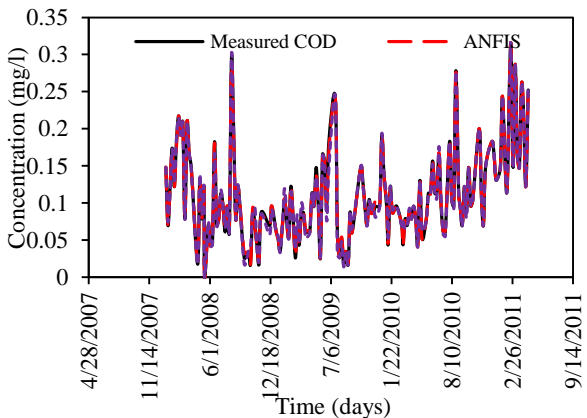

Figure 5a Training performance for effluent COD prediction

3.1.2 Effluent SS Prediction

Figure 6a illustrates The Prediction Of The Models During Training Phase; The Models Were Able To Accurately The Measured Values Of The Suspended Solids. As Presented In Table 1 The MAPD For ANFIS Is 0.432% And For The FFNN Is 2.06 % Which Indicated That The Model Are Highly Accurate Having MAPD Less 10%. However, In Figure 6b During Validation Phase, The Performance Of ANFIS Is Better Than FFNN As There Are Many Drifts In FFNN Model.

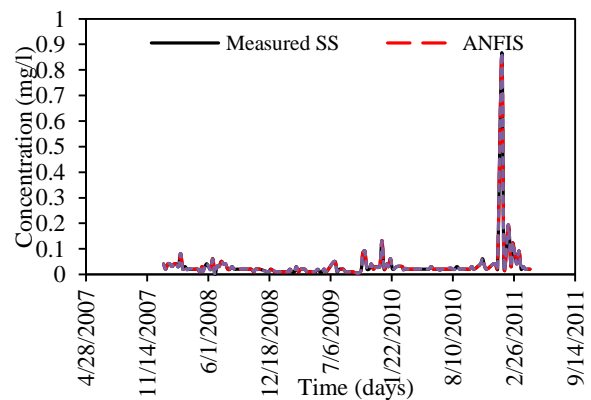

Figure 6a Training performance for effluent SS prediction

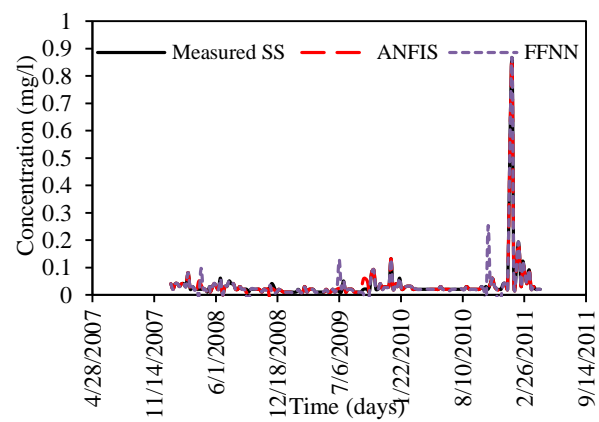

Figure 6b Validation performance for effluent SS prediction

3.1.3 Effluent NH₄-N Prediction

During the training the predicted values by the models were in total agreement with that of the measured values as shown in Figure 7a.

Minimal values of the error measures signify how accuracy of prediction. In Figure 7b, during validation the prediction errors were slightly high which resulted in having MAPD in both models above 10%, however, the performance are quite remarkable.

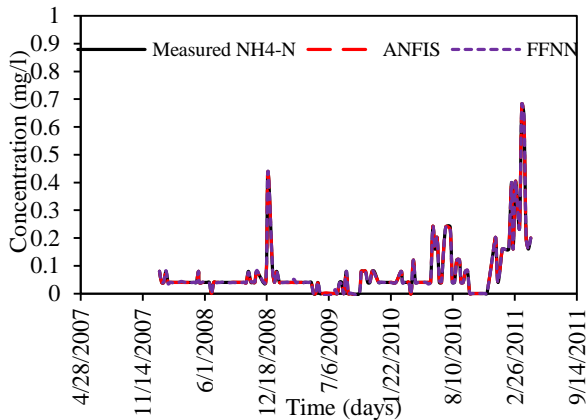

Figure 7a Training performance for effluent NH4-N prediction

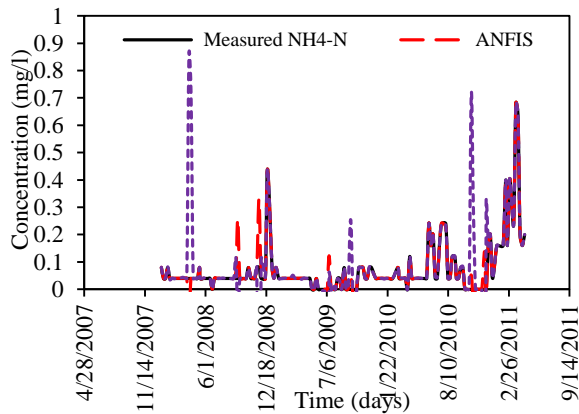

Figure 7b Validation performance for NH4-N prediction

4.0 CONCLUSION

In this paper, ANFIS model for carbon and nitrogen removal in domestic wastewater treatment plant has been presented. Although both the ANFIS and neural network models have demonstrated a great capability of effectively predicting the effluent variables of the plant, however, the results obtained with ANFIS approach are better compared to that of the neural network. Perhaps increasing the number of neurons in the hidden layer or providing enough training time could increase the performance of the neural network to achieve the results as close as that of ANFIS. The proposed ANFIS model may serve as a versatile and useful tool for the wastewater treatment plant.

Acknowledgement

The authors wish to thank the Research University Grant (GUP) vote Q.J130000.2523.02H70 Universiti Teknologi Malaysia for its financial support and the IWK staff of Bunus regional sewage treatment plant for their support and cooperation.

References

- [1] M. Henze, W. Gujer, T. Mino, and M. van-Loosedrecht. 2000. *Activated sludge models ASM1, ASM2, ASM2d and ASM3*, IWA Scient. London, UK: IWA Publishing.
- [2] A. Nagy, G. Mourot, and B. Marx. 2010. Systematic Multimodeling Methodology Applied to an Activated Sludge Reactor Model. *Industrial and Engineering Chemistry Research*. 49: 2790–2799.
- [3] M. Huang, Y. Ma, and J. Wan. 2012. Modeling a Paper-Making Wastewater Treatment Process by Means of an Adaptive Network-Based Fuzzy Inference System and Principal Component Analysis. *Industrial and Engineering Chemistry Research*. 51(17): 6166–6174.
- [4] A. Benhalla, M. Houssou, and M. Charif. 2010. Linearization of the Full Activated Sludge Model No 1 for Interaction Analysis. *Bioprocess and Biosystem Engineering*. 33(6): 759–771.
- [5] A. Perendeci, S. Arslan, S. Celebi, and a Tanyolac. 2008. Prediction of Effluent Quality of an Anaerobic Treatment Plant Under Unsteady State through ANFIS modeling with on-line Input Variables. *Chemical Engineering Journal*. 145(1): 78–85.
- [6] G. Civelekoglu, N. O. Yigit, E. Diamadopoulos, and M. Kitis. 2009. Modelling of COD Removal in a Biological Wastewater Treatment Plant Using Adaptive Neuro-Fuzzy Inference System and Artificial Neural Network. *Water Science and Technology*. 60(6): 1475–87.
- [7] J. Ragot, G. Grapin, P. Chatellier, and F. Colin. 2001. Modelling of a water treatment plant. A multi-model representation. *Environmetrics*. 12(7): 599–611.
- [8] G. Civelekoglu, A. Perendeci, N. O. Yigit, and M. Kitis. 2007. Modeling Carbon and Nitrogen Removal in an Industrial Wastewater Treatment Plant Using an Adaptive Network-Based Fuzzy Inference System. *CLEAN – Soil, Air, Water*. 35(6): 617–625.
- [9] J. Jang. 1993. ANFIS: Adaptive-network-based Fuzzy Inference System. *IEEE Transactions on System, Man and Cybernetics*. 23(3): 665–685.
- [10] A. Azar. 2010. Adaptive Neuro-fuzzy Systems. *Fuzzy Systems*. INTECH, Rijeka, Croatia.
- [11] M. Denai, F. Palis, and A. Zeghib. 2004. ANFIS based modelling and control of non-linear systems: a tutorial. *IEEE International Conference on System, Man and Cybernetics*, Oran, Algeria. 3433–3438.
- [12] J. Jang, C. Sun, and E. Mizutani. 1997. *Neuro-fuzzy and soft computing: A Computational Approach to Learning and Machine Intelligence*. New Jersey: Prentice Hall.
- [13] A. Engelbrecht. 2007. *Computational intelligence: An Introduction*. U.S.A: Wiley and Sons Ltd.
- [14] S. Sumathi and S. Paneerselvam. *Computational Intelligence Paradigms: Theory & Applications Using MATLAB*. U.S.A: CRC Press.
- [15] S. Nissen. 2003. Implementation of a Fast Artificial Neural Network Library (fann). In Graduate Report.
- [16] R. Hecht-Nielsen. 1987. Kolmogorov's Mapping Neural Network Existence Theorem. In Proceedings of the First IEEE International Joint Conference on Neural Networks. 11–14.