

SEA CLUTTER CHARACTERISATION & SMALL TARGET  
DETECTION IN MARITIME SURVEILLANCE RADAR

NADARAJ A/L CHIDAMBARAM

UNIVERSITI TEKNOLOGI MALAYSIA

SEA CLUTTER CHARACTERISATION & SMALL TARGET  
DETECTION IN MARITIME SURVEILLANCE RADAR

NADARAJ A/L CHIDAMBARAM

A dissertation submitted in partial fulfillment of the  
requirements for the award of the degree of  
Master of Engineering (Electrical – Electronic & Telecommunication)

Faculty of Electrical Engineering  
Universiti Teknologi Malaysia

MARCH, 2005

Dedicated to my beloved parents and to Glenda – my wife, my friend, my love and  
to our childrens.

## **ACKNOWLEDGEMENT**

Appreciation is expressed to the radar engineers and radar researchers I was in contact during the preparation of this thesis. In particular I would like to thank my main thesis supervisor, Associate Professor Dr. Ahmad Zuri Sha'ameri for the encouragement, suggestions, comments and friendship.

The support of the company Terma A/S Radar Division Lystrup, Denmark and in particular Dr Jens Erik Lolck, Senior Radar System Analyst and Mr Ole Heigaard, Sales Director for their contribution in providing me the recorded raw radar video for my thesis analysis and for future research work considerations.

Finally, on a more personal level, I wish to thank my wife Glenda and my children's for their patience and understanding during the preparation of the thesis.

## **ABSTRACT**

Maritime surveillance radar experiences serious limitations imposed on their performance by unwanted sea clutter. Sea clutter limits the performance of the radar, so it is vital to understand the characteristics of sea clutter to improve the performance in detecting small targets. A detail analysis of experimental live recorded radar data collected at Port Hanstholm, Denmark with Terma Scanter X band Radar was used to test the theoretical and experimental models developed by many researches on sea clutter. The amplitude video voltage of collected digitized raw video consisting of targets and clutter of each radar sweep were measured and analyzed. The histogram from the collected samples of echo returns were plotted, a comparison of the amplitude histograms with Gaussian and Rayleigh distributions were done. The analysis of the recorded amplitude histogram has demonstrated for high resolution with low grazing angle and using horizontal polarization the data distribution fits the log normal distribution. The study concludes the statistics of sea clutter vary with polarization, resolution cell size, sea state and wind conditions.

## ABSTRAK

Sistem pengawasan radar maritim menghadapi dari segi kemandapan prestasi akibat daripada “unwanted sea clutter” pada tahap kritikal. “Sea clutter” mengakibatkan berlakunya kelembapan prestasi radar dan adalah menjadi keutamaan dalam memahami karakteristik “sea clutter” dalam mengembalikan prestasi mengesan sasaran-sasaran kecil. Kajian terperinci hasil daripada rakaman data-data eksperimen radar secara langsung telah dijalankan dan dikumpul di Port Hanstholm, Denmark diperolehi melalui sistem Terma Scanter radar jalur frequency X digunakan untuk menguji secara teori dan mengeksperimentasikan model yang telah diusahakan oleh pengkaji dalam bidang “sea clutter”. Ukuran dan kajian terhadap amplitud voltan video hasil daripada pengumpulan raw video yang telah didigitalkan mengandungi setiap sasaran berserta clutter bagi setiap “radar sweep”. Sampel-sampel pembalikan gema yang dikumpul, diplotkan didalam carta histogram dimana hasil perbandingan diantara amplitud histogram serta taburan Gaussian dan Rayleigh telah berjaya diperolehi. Manakala melalui penggunaan “horizontal polarization”, taburan data-data yang tersebar memenuhi kriteria taburan lognormal. Analisis hasil daripada amplitud histogram yang telah dirakam mempamerkan resolusi tinggi bersamaan low grazing angle. Kesimpulannya, kajian menunjukkan perbezaan statistik “sea clutter” di pengaruhi kepelbagaian faktor termasuklah polarisasi, saiz resolution sel, keadaan laut dan angin.

## TABLE OF CONTENTS

CHAPTER	TITLE	PAGE
1	INTRODUCTION	1
	1.1 BACKGROUND	1
	1.2 RESEARCH OBJECTIVE	2
	1.3 SCOPE OF RESEARCH	3
	1.4 PROBLEM STATEMENT	4
	1.4.1 Problem Description	5
	1.5 RESEARCH OUTCOME	6
	1.6 RESEARCH METHODOLOGY	6
	1.6.1 Experimental Measurements	7
	1.6.2 Radar Antenna System Parameters	8
	1.6.3 Measurement System Block Diagram	9
	1.6.4 Measurement Methods	10
	1.6.5 Measurement Geometry	11
2	LITERATURE REVIEW	13
3	THEORETICAL FOUNDATION	16
	3.1 Radar and Target Detection Principles	16
	3.2 Sea Clutter and Sea States	18
	3.3 Sea Clutter Factors	19
	3.3.1 Effect of Wind and Waves	16
	3.3.2 Sea State Scales	20
	3.3.3 Polarization	20

	3.3.4 Sea Spikes	21
	3.4 RADAR CLUTTER	23
	3.4.1 Backscatter from sea surface	23
	3.4.2 Description of the Sea Surface	23
	3.5 RADAR CLUTTER MODELLING	24
	3.5.1 Noise Clutter	24
	3.5.2 Probability Distributions	25
	3.5.3 K Distribution	26
	3.6 CLUTTER MODELS	28
	3.6.1 General Characteristics of $\sigma^\circ$	29
	3.6.2 Surface Clutter Radar Equation	30
	3.6.3 Surface Clutter Models	34
4	DATA COLLECTION AND ANALYSIS	37
	4.1 Data Collection and Setup	37
	4.2 Radar Calculation	38
	4.3 Data Analysis	40
5	RESEARCH RESULTS	44
	5.1 Main results	44
	5.2 Research results and discussion	46
	5.2.1 Result 1: Sea Clutter distribution Analysis	48
	5.2.2 Result 2: Effect of high resolution and low grazing	50
	5.2.3 Result 3: Pulse length and horizontal polarization	51
6	RESEARCH CONCLUSION	52
	REFERENCES	54



**LIST OF TABLES**

<b>TABLE NO.</b>	<b>TITLE</b>	<b>PAGE</b>
1.1	Radar Parametrs	8
1.2	Antenna Parameters	8
3.1	Normalized Mean Back Scatter Coefficient $\sigma^\circ$	12

## LIST OF FIGURES

<b>FIGURE NO.</b>	<b>TITLE</b>	<b>PAGE</b>
1.1	Measurement System Block Diagram	9
3.1	Envelope of receiver output illustrating false alarms	17
3.2	Composite of $\sigma^\circ$ for medium sea	18
3.3	Geometry of radar clutter	31
4.1	Back Scatter reflection coefficient	39
4.2	Range Intensity Plot on A Scope	40
4.3	Amplitude variation of sea clutter	41
4.4	Received powers from sea clutter and target (RCS 1 sq m)	42
4.5	Sea clutter amplitude observation	43
4.6	Distinct point like echoes with regions of very low signal	43
5.1	Amplitude histogram of referenced target and clutter	46
5.2	Amplitude histogram of clutter without presence of target	47
5.3	Lognormal pdf of echo data	49

## LIST OF SYMBOLS

$\Psi$	-	Grazing angle
$\sigma$	-	Radar cross section
$\sigma_c$	-	Clutter cross section
$\sigma_m$	-	Median value of $\sigma_c$
$\sigma_t$	-	Radar cross section of target
$\sigma^0$	-	Echo intensity, backscatter coefficient
$\sigma^2$	-	Variance
$\theta_B$	-	Azimuth beam width
$\eta^2$	-	Peak Signal-to-Noise Ratio
$c$	-	Speed of light
$\Gamma$	-	Pulse Width
$\Gamma(.)$	-	Gamma function
$\theta_1(t)$	-	Phase modulation
$\omega_c$	-	Carrier frequency
$\beta^r$	-	Reflection gain
$\omega_d$	-	Doppler shift
$\gamma$	-	Threshold
$\mu$	-	Mean

## LIST OF ABBREVIATIONS

APDF	-	Amplitude Probability Density Function
$A_e$	-	Effective aperture of the antenna
$A_c$	-	Area of sea surface clutter
A/D	-	Analog to digital
B	-	Noise bandwidth of receiver
C	-	Clutter power
$E_i$	-	Electric field strength incident on target
$E_r$	-	Electric field strength return
G	-	Antenna gain
h	-	Height of antenna
PDF	-	Probability Distribution Function
pdf	-	probability density function
PRF	-	Pulse Repetition Frequency
$P_d$	-	Probability of Detection
$P_{fa}$	-	Probability of False Alarm
$P_m$	-	Probability of Miss Target
$P_r$	-	Received power
$P_t$	-	Transmitted power
R	-	Range of target
$R_{max}$	-	Maximum radar range
RADAR	-	RADio Detection And Ranging
S	-	Signal power
$S_{min}$	-	Minimum detectable signal
SNR	-	Signal to Noise Ratio

## CHAPTER 1

### INTRODUCTION

In maritime surveillance, radar echoes which clutter the radar and challenge small target detection. Clutter is unwanted echoes that can make target detection of wanted targets difficult by radar. The characteristic of radar sea echo are of interest in number of application areas, such as maritime surveillance, radar remote sensing and search and rescue mission. This thesis will use recorded raw video data to analyze the characteristic of sea clutter, this chapter provides the objective, problem statements, research methodology and research methodology.

#### 1.1 Background

The term **radar** derived from the original name given to this technique by British inventors during World War II, which was *Radio Detection And Ranging*. Radar is an electromagnetic system for the detection and location of objects. It can be used to detect targets such as low flying aircraft, ships and small marine targets. The performance of radar may be dependent on the characteristics of particular operational scenarios, such as open-ocean, coastal waters, presence of sea clutter, wind direction, high target densities, sea state, target clutter interaction, radar cross section.

Radar operating in a maritime environment experiences serious limitation imposed on their performance by unwanted sea clutter (sea echoes). Sea clutter limits the performance of maritime surveillance radar, so it is vital to understand the

characteristics of sea clutter to improve the performance in detecting small targets. At home surveillance of the Straits is a national interest to protect our coastline due to the increase in smuggling, illegal immigrants and pirate attacks; the Maritime Enforcement Agencies require detecting small fast moving targets embedded in sea clutter and to conduct Search And Rescue. The need for understanding the sea clutter characteristics in the Straits of Malacca and South China Sea may be required to in the future meet our requirements for Coastal Surveillance and for Maritime Situational Awareness. Sea clutter has been studied and ongoing researchers are being conducted by many researchers, and many experimental and theoretical results have been published. Most published results are dependent on the radar and environmental parameter; as such this research will focus primarily on analysis of radar detection of targets in sea clutter using processed recorded live data. The detection schemes and signal processing techniques are used on the real time radar data and the processed digitized data was recorded for the research. By performing the analysis on the recorded data, the validity of theoretical analysis on sea clutter models and radar performance can be verified and understood.

## **1.2 Research Objective**

The main objectives of this research is to use the theoretical foundation of sea clutter to analyze the recorded radar video, the following are the objectives will be met.

1. Radar detection of targets in sea clutter by analyzing processed recorded live data.
2. Discussion of statistical distribution in modeling target detection in sea clutter.
3. Analyze radar performance parameters in detection of targets in modern radar systems.
4. Suppression of spiky sea clutter and detection of constant signal in modern radar systems.

### 1.3 Scope of Research

Most research on target detection in sea clutter is performed using specialized radar system to investigate sea clutter characteristics to improve the performance of the radars. The collection of radar data requires specialized data measurement tools, detection schemes, instrumentation radar, calibrated target and environmental conditions. It should be noted that it is difficult to describe the characteristics of sea clutter as a simple model because sea clutter is dependent on each radar system performance and many other environmental parameters. However, the research for this paper will use processed radar data obtained from operational modern radar system. The processed radar data have been digitized and it is obtained from the radar signal distribution interface of the radar transceiver. The data acquisition, storage systems and calibration techniques were consistent during the collection of data for this research.

The radar transceiver consists of signal processing plug in modules primarily intended for coastal surveillance to improve detection of marine targets of various radar cross section (RCS). The discussion on signal processing will be limited as it is a comprehensive subject outside the scope, however the specific functions of the signal processing cards will be highlighted.

The changing of radar parameters (pulse width, STC, FTC) and analyzing it are beyond the scope of this study, as this would lead to interruptions of the user's operational requirement and requires more time. The radars were carefully configured to permit accurate measurements of the pulse to pulse fluctuations of the radar targets and sea clutter return. Also the small targets in clutter were enhanced by the signal processing in the radar transceiver which is beyond the scope of our work.

The data was collected using Terma commercial X band 25 kW marine radar operating in 9410 MHz, consisting of programmable pulse width, horizontal polarized and high gain slotted wave guide antenna. The details of the radar antenna system description will be provided in another section.

The radar detection experiments results of some measurements conducted in Hanstholm, Denmark in January 2005 by the Terma Radar Systems Division. The radar site was located overlooking the open sea at a Port area. The data collection was conducted for a period of 1 week.

The obtained data may not reflect the different sea states, wind and environmental conditions the research may only provide sufficient real time data in estimating radar performance detection for small target at sea and clutter characteristics. In addition the scope of work will identify estimates of signals received from a target and background clutter (sea, ships, infrastructure) will be performed. This research will also outline the radar performance prediction model for target detection at sea.

There are several ways of analyzing the obtained data, such as the specifying amplitude statistics, frequency domain analysis and correlation analysis. This research will only focus on the amplitude statistics of sea clutter and targets. For detection in sea clutter, the minimum characteristics that are required will be used for valid data collection, the research will test the theoretical models developed in the literature review.

#### **1.4 Problem Statement**

The performance of maritime surveillance of high resolution radars in the detection and tracking of targets with low radar cross section (RCS), such as small wooden boats, buoys and submarine periscopes seriously affected by the strong target like returns from the sea surface.

In this research paper, the interest is in understanding the models that fits the characteristics of sea clutter and perform research analysis on the recorded radar data from a marine environment with various clutter and targets.



### 1.4.1 Problem Description

The problem concerning target detection is that the user must have confidence that if a target which the radar is designed to detect is present within the radar coverage volume, the radar will reliably detect it. The problem of target detection involves successfully achieving a balance between the two requirements: the radar receiver must be sensitive to detect very small signals, due to the high sensitivity requirement thus noise and clutter are detected as well. The result is the presence of unwanted targets and false alarms. Unwanted targets can be dealt with post detection processing, but false alarms on the other hand are the consequence of noise like interference exceeding the detection threshold established for the radar, and can never be eliminated.

Radars operating in maritime environment have a serious limitations imposed on their performance by unwanted sea echoes (sea clutter). For many years, earlier radars with low resolution capabilities, these sea clutter echoes were considered as a Gaussian distributed disturbance. At present the modern radar systems, operating at low grazing angles and with high resolution capabilities, the statistics of the sea clutter have been observed to deviate from the normality. The disturbance is spikier than the Gaussian distribution and the spikes are processed by the radar detection process as targets, with increasing false alarm rate.

Observations and literatures have been documented that performance of high resolution radar in the detection and tracking of targets with low (RCS) radar cross section (i.e. small wooden and fiber glass boats carrying unwanted guests, fishing boats) may be seriously affected by the strong statistical properties of target like returns from the sea (sea spikes), that can occur at very low grazing angles. With this problem in mind, thus an understanding of sea clutter at low grazing angles and high resolutions is a prerequisite for the research.

Therefore, in summary a problem of fundamental interest in the radar community is the modeling of non-Gaussian clutter.

## **1.5 Research Outcome**

Although the research primarily involves the statistical studies of sea clutter characteristics in small target detection, the research outcome is expected to be beneficial in what will be required in understanding the theory of sea clutter statistics in our region and type of distribution model it fits into. In summary, contributions expected outcome of the research to assist the radar systems engineer in understanding the parameters and specification criteria that will be required in improving maritime surveillance radars performance and the main outcome are highlighted below.

- i. Better understanding of sea clutter characteristics.
- ii. The probability densities and distributions of received power from sea clutter under our environmental conditions
- iii. Data collected can be of importance to our Navy and Maritime Enforcement Agency;
- iv. Clutter models can be used in specification preparation of radar performance in sea clutter for small targets;
- v. Improve detection performance of small targets in sea clutter

## **1.6 Research Methodology**

The research methods and experiments that have been conducted by industries and universities have conducted extensive sea clutter measurements using various radar parameters. The experimental measurements that has been conducted by Fred L.Posner (1990)), Simon Haykin, Sadsivan Puthusserypady (2002),Ward et.al. (1990) and their developed theoretical models will be used to perform the analysis on the recorded radar data.

J. Ryan and M. Johnson (1990) has discussed in great length that major difficulty in estimating radar performance for small target detection is often limited by sea clutter.

### **1.6.1 Experimental Measurements**

The analysis of a set of recorded live data was recorded by Terma Radar Systems Division in January 2005 and provided the author of this research paper to perform the analysis and verification in the radar detection of targets and in understanding sea clutter behaviour. The availability of the recorded sets of data for analyses is essentially studies of opportunity for the industries and research communities in Malaysia.

The radar antenna was installed at Port Hanstholm, Denmark, 35m AMSL. Non-coherent high resolution radar was installed for Vessel Traffic Management experiments in detecting large vessels, ferries and small boats.

The antenna located inside the Port overlooking the berthing area and the open sea. During the experiment, available wind conditions and sea state were used during the recording. The weather condition was clear and the data was recorded during the day sometime January 24, 2005.

The raw video data returns consisting of target and clutter echoes were digitized by an 8 bit A/D converter. The sampling rate of 40 MHz was used. The data logger PC was connected to the digital video output with video amplitude resolution of 8 bits. The data was recorded on the PC's hard-disk.

The Table 1.1 and 1.2 below provides the radar antenna system configuration used for the measurements and how data collection was performed.

### 1.6.2 Radar Antenna System Parameters

The complete radar system descriptors used in experimental data collection and radar parameters for detection in sea clutter required for the measurements are provided in the table below.

**Table 1.1: Radar Parameters**

Radar: Terma Scanter 2001	Terma Denmark
Transmit Frequency	9410 MHz
Pulse width	120 ns- 300 ns
Range Cell Resolution	6 m
Range Cell Size	3. 75 m
Pulse Repetition frequency	3000 Hz
Signal Processing	Sample Rate 40 MHz

**Table 1.2: Antenna Parameters**

Antenna	Terma
Antenna Length	18 feet
Antenna Height	35 m AMSL
RPM	12
Antenna Beamwidths @ - 3 dB	$\leq 0.41^\circ$
Antenna Gain	$\geq 35$ dB
Polarization	Horizontal
Operating range	25 nm (50 km)

For the sea clutter characterization the following parameters were inherent in the study:

- i) Radar grazing angle ( determined by radar height and radar range);
- ii) Radar frequency
- iii) Sea state
- iv) Radar polarization

- v) Receiver gain
- vi) Sampling frequency, Pulse Repetition Frequency

The radar equipment used is from Terma Scanter radar antenna system. The radars are predominantly used for Vessel Traffic System and Coastal Surveillance. The system is characterized by high resolution, high gain and noise reduction facilities.

The radar is a mono frequency X band radar operating with Horizontal polarization, it uses pulse magnetron, non-coherent radar. The radar under test will use only the envelope of the received signal in their processing, they do not use the signal phase, the radar system can be non-coherent from pulse to pulse.

The radar has programmable PRF and pulse width, for this experiment we used a PRF of 3000 Hz and pulse width of 120 ns during the measurement. The radar rotation rate of 12 revolutions per minute, and detection of 3 out of 5 scans were used.

### 1.6.3 Measurement System Block Diagram

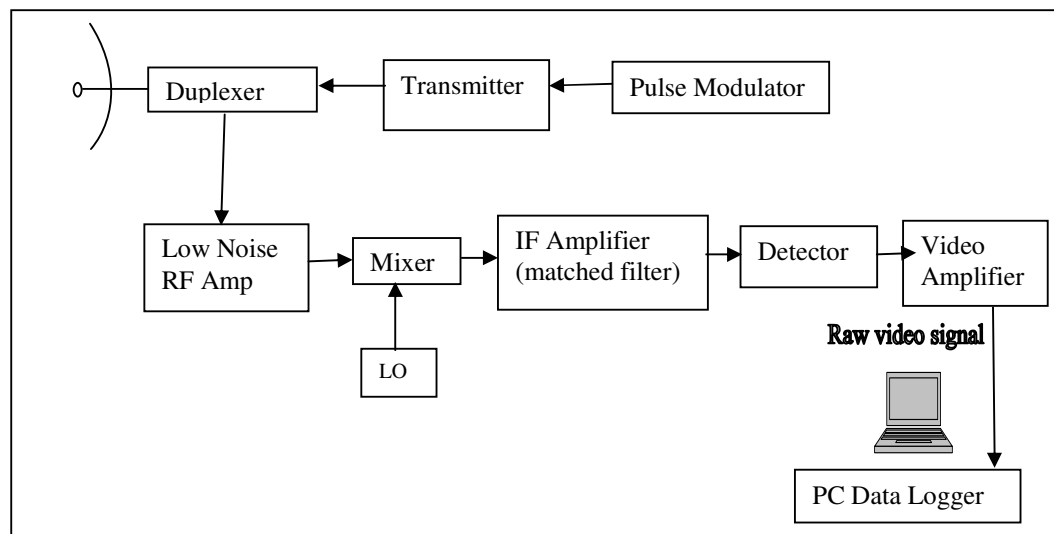

**Figure 1.1:** Measurement System Block diagram

#### 1.6.4 Measurement Methods

The optimized PRF of 3000 MHz and pulse width of 120 ns of the high resolution X band radar was used during the test ensuring targets and clutters are collected. The digital video output of the transceiver was connected to the PC video input to record the observed data in range, azimuth and the raw data collected by each antenna scan. The recorded data will be stored in a PC and time-stamped.

There were several large vessels with RCS of 100 m<sup>2</sup> and small boats with RCS of 15m<sup>2</sup> were found within the radar coverage during the test. The radar settings were optimized for performance by detecting the vessels of opportunity over a coverage area of 25 km. The radar overlooks a portion of the land area, the land area was masked and the radar stops its transmission when looking at the land area.

After the radar settings were confirmed, the radar antenna system was made to radiate the high frequency pulse trains by means of a magnetron. The radar returns were observed for confirmation on the A-Scope provided by the PC display. The A-Scope presentation is similar to the PPI display found in the ship based radar. Here the A-Scope is predominantly used by radar research for visual observation of the radar returns with specialized software running in parallel to display the echo power or amplitude returns of the radar returns. There are many features that are available on the viewer display, where we can control the range of interest, the area of interest of the radar sweep, the look direction of the radar, after glow and video gain can be used to verify the dynamic nature of the sea clutter and the persistent returns of real targets.

The radar replay of the Range Voltage Intensity provides the video amplitude of the radar returns in dB at the respective range of interest. Histograms of the radar returns with mean and standard deviation can be found using the available features.

By observing the returns, the video voltage returns consisting of targets and clutter were monitored and logged real time onto the PC's hard disk. The data sets were time stamped accordingly.

To facilitate the target and clutter measurements, the following experimental steps were executed.

1. The received video voltage of the targets and clutter returns were recorded real time;
2. The amplitude data was recorded for every sweep angle;
3. Measure the amplitude returns within 15 km range at real time;
4. Reference target RCS was used in relation to real clutter. Other small targets of opportunity were also used for the measurements;
5. Record the clutter towards and surrounding a reference target in range and direction of the sweep (radar pulse transmission);
6. Record the raw video sample data in suitable in a suitable format for analysis;
7. Derive histograms from collected samples of echo returns;
8. Fit the obtained data to available sea clutter distribution models, and make the analysis;
9. Compare the obtained data to the other existing models and provide conclusion.

These data collections runs typically lasted over 600 seconds, one scan occupied 16 MB. Each of the three dataset files collected had 20 scans of data sufficient to conduct the analysis.

### **1.6.5 Measurement geometry**

The itemized description of the measurement radar antenna appears in Table 1.1 and Table 1.2. For sea clutter measurements, there are several descriptors that influence the sea clutter characteristics. The major descriptors that were considered were grazing angle (determined by radar height and distance to area of interest), transmit geometry (determined by the radar bearing and wind direction) and polarization. During the measurements the existing wind speed and sea state conditions were used.

This is further confirmed by Posner (1998), he performed a study on the spiky sea clutter and noted that the richly complex behaviour of sea clutter at low grazing angles and high range resolutions is strongly dependent upon transmit geometry and polarization, as well as scale of observation.



polarization. These results have been confirmed and documented in the Nathanson model by Nathanson (1990).

The study concludes that the statistics of sea clutter (amplitude distribution) vary with polarization, resolution cell size, sea state and wind conditions. If the resolution cell area is large enough relative to the ocean structure, the clutter will have a Gaussian (normal) probability distribution at input to receiver and Rayleigh distribution at output of receiver. In our study the clutter did not exhibit Gaussian probability distribution, but log normal (short pulse length, high resolution, low grazing angle).

The significance of this research paper has also found that the conclusion drawn from this research and the results reported by other researches are consistent. The research also concludes that different probability distributions would be needed to best fit the data of different polarization and the statistical behaviour of the variations in sea clutter return is considerable interest to the radar designer.

## LIST OF REFERENCES

1. Anastassopoulos, V., Lampropoulos, G.A., Drosopolous, A., and Rey, M. (1999) *High resolution radar clutter statistics*. IEEE Trans., 1999, 43-60.
2. Ekstrom, J.L (1973). *The detection of steady targets in Weibull clutter* in 'Radar present and future', IEEE Conf. Publ. 105, London Oct. 1973, pp 221-226
3. Farina, A. Russo, A and Scannapieco, F (1987). *Radar detection in coherent Weibull clutter*, IEEE Trans., 1987, ASSp-35, pp. 893-895.
4. Farina, A., A. Russo, and F.A. Studer . *Coherent Radar Detection in Log – Normal Clutter*. IEE Proc. 133, Pt. F 1986, pp-54.
5. Farina, A., Gini, F., Greco, M. V., and Verrazani, L. (1997). *High resolution sea clutter data: statistical analysis of recorded live data*. IEE Proc. Radar, Sonar, Navigation, 144, 3 (June 1997), 121-130.
6. Goldstein, G.B(1973). *False alarm regulation in log normal and Weibull clutter*, IEEE Trans., 1973, AES-9 pp.84-92
7. Haykin S., R. Bakker, and B. Currie (2002). *Uncovering nonlinear dynamics: The case study of sea clutter*, Proc. IEEE, May 2002.
8. Jackson, J and R. Moses (2002). *Clutter modeling Analysis with Mixture models presentation*, 2002.
9. Marcum J.I (1960), *A statistical theory of target detection by pulsed radars*, IEEE Trans Vol It-6, 82-83
10. Nathanson F (1990). *Radar Design Principles* 2<sup>nd</sup> ed. 1990 McGraw Hill
11. Oliver, C.J (1988). *Representation of Sea Clutter*: IEE Proc. 135, pt. F, pp.497-500.
12. Pentini, F.A., A.Farina, and F Zirilli (1992). *Radar Detection of Targets Located in a Coherent K Distributed Clutter Background*. IEE Proc. 139. Pt. F, 1992, pp. 239-245.
13. Posner F (1998), *Spike Sea Clutter at Low Grazing Angles and High Range Resolutions*, IEEE National Radar Conference. Dallas May 1998.
14. Prat T. (2003). *Radar Lecture Notes* ECE 5635, 2003.

15. Sangston, K.J.(1998). *Coherent Detection of Radar Targets in K Distributed, Correlated Clutter*. Naval Research Laboratory, Washington, D.C., Report 9130, August, 1988.
16. Sekine (1980), et. Al. *Log-Weibull Distributed Sea Clutter*. IEE Proc. 127, Pt. F (June 1980), pp.225-228.
17. Skolnik M.I, (1990). *Introduction To Radar Systems*, 2<sup>nd</sup> ed. New York, McGraw Hill.
18. Skolnik M.I, (1990). *Radar Handbook*, 2<sup>nd</sup> ed. New York, McGraw Hill.
19. Swerling P (1957). *Detection of fluctuating pulsed signal in the processing of noise*. 1957, IEEE Trans Vol It-6, 269-308
20. Schleher, D.C.(1976). *Radar detection in Weibull clutter*.IEEE Trans., 1976, AES-12,pp. 736-743.
21. Trunk, G.V and George , S.F (1970). *Detection of targets in non-Gaussian sea clutter*. IEEE Trans., 1970, AES-6, pp.620-628
22. Trunk G.V. (1971).*Further results on the detection of targets in non-Gaussian sea clutter*. IEEE Trans., 1971, AES-7, pp. 553-556
23. Trunk, G.V.(1971). *Detection of targets in non-Rayleigh sea clutter*. IEEE EASCON Record 1971, pp 239-245
24. Trunk, G.V.(1972). *Radar Properties of Non-Rayleigh Sea Clutter*. IEEE Trans. AES-8 (March 1972), pp. 196-204.
25. Tough , R. J. A., C. J. Baker, and J.M. Pink (1990). *Radar Performance in a Maritime Environment: Single Hit Detection in the Presence of Multipath fading and Non-Rayleigh Sea Clutter*. IEE Proc. 137, pt. F (February 1990), pp.33-40.
26. Ward K.D. (1981). *Compound representation of high resolution sea clutter*. 1981, Electronics Letter 17 (16), 561-563.
27. Ward K.D. (1982). *A radar sea clutter model and its application to performance assessment*. 1982, Radar 82 Conf, 203-207.
28. Ward, C.J Bakker and S. Watts (1990). *Maritime surveillance radar Part I: Radar scattering from the ocean surface*. IEE Proceedings. April 1990. Vol. 137, Pt.F No.2, pp.51-62.
29. Wetzel, L. B.(1990). *Electromagnetic Scattering from Sea at Low Grazing Angles*. In Surface Waves and Fluxes. Vol.11 Netherlands: Kluwer Academic, 1990, chap. 12, pp. 109-171.