



Sharif University of Technology

Scientia Iranica

Transactions D: Computer Science & Engineering and Electrical Engineering

www.sciencedirect.com



Research note

Measurement of velocity of solid/air two phase fluid using electrostatic sensors and cross correlation technique

H. Seraj^a, M.F. Rahmat^{b,*}, M. Khalid^{a,1}

^a Center for Artificial Intelligence and Robotics (CAIRO), University Technology Malaysia International Campus, Jalan Semarak, 54100 Kuala Lumpur, Malaysia

^b Department of Control and Instrumentation Engineering, Faculty of Electrical Engineering, University Technology Malaysia, Johor Bahru, 81310 Skudai, Malaysia

Received 11 September 2011; revised 29 April 2012; accepted 18 July 2012

KEYWORDS

Cross correlation;
Electrostatic sensor;
Solid/air fluid;
Velocity measurement.

Abstract In this paper, application of the cross correlation method for estimating the velocity of air/solid fluid is explained. Electrostatic sensors are used as the primary sensors for this measurement and by using the cross correlation of signals from two electrostatic sensors, the speed of air/solid fluid is calculated. In calculating cross correlation, a truncated version of cross correlation is considered in order to perform cross correlation in an on-line mode. Also, to improve the accuracy of truncated cross correlation, it is performed only when a particle passes across the sensors. MATLAB is selected as the programming tool for performing the cross correlation algorithm. Different tests have been performed, in which the distance between two electrostatic sensors is set at various specified values, and the calculated velocities of solid particles are compared. It is shown that the results of these measurements are very similar, which is proof of the correctness of the results.

© 2013 Sharif University of Technology. Production and hosting by Elsevier B.V.

Open access under [CC BY-NC-ND license](#).

1. Introduction

There are numerous applications in industry where solid particles are transferred with pneumatic force (i.e. pressurized air). For instance, in burner systems, coal particles are transferred with pneumatic force to the burner chamber. In the mining industry, the particles of minerals (cement, nickel, iron, etc.) are transferred with pressurized air along the pipes and ducts for further processing. For several reasons, measuring the velocity of solid particles is very important in these applications. For example, the mass flow rate of the solid particles can be calculated by measuring the velocity of solid particles and multiplying this velocity with the concentra-

tion of the particles. Also, measuring the velocity of solid particles is important in knowing the effects of particles on pipeline erosion, since more velocity causes more erosion in the pipeline.

Electrostatic sensors are widely used in solid/gas applications where solid particles carry electrostatic charges [1]. Electrostatic sensors are providing a non-intrusive method for measuring the velocity of fluid in solid/gas applications and, therefore, are less susceptible to wear and erosion. Various shapes of electrostatic sensor are used for solid air flow measurement, such as pin, quarter-turn or ring type [1]. The cross correlation method is an effective way to measure velocity, since it is sensitive to the peak voltage in the sensor output and, therefore, is less sensitive to the noise and DC level [2]. The cross correlation method can be realized using different types of sensing element. Among them, electrostatic sensors are most widely used, due to their good performance in solid/air situations and also due to their non-intrusive arrangement. Various investigations have been performed for modelling the output of electrostatic sensors on pipelines with circular and rectangular cross sections [3–5]. In this paper, we use electrostatic sensors and the cross correlation method for deriving the velocity of solid/air particles.

* Corresponding author.

E-mail addresses: serajhossein@yahoo.com (H. Seraj), fuaad@fke.utm.my (M.F. Rahmat), marzuki@utm.my (M. Khalid).

¹ Deceased author.

Peer review under responsibility of Sharif University of Technology.



Production and hosting by Elsevier

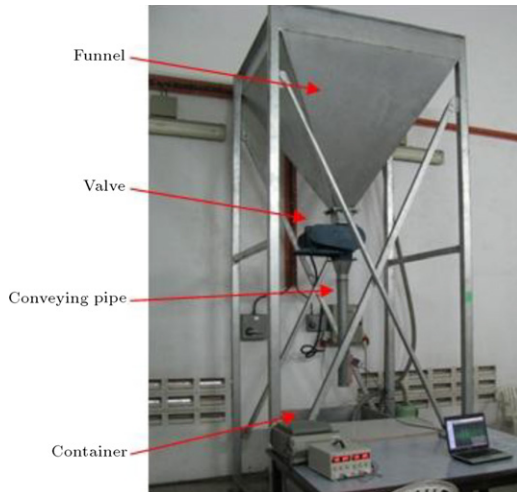

Figure 1: Test rig for solid/air flow measurement.

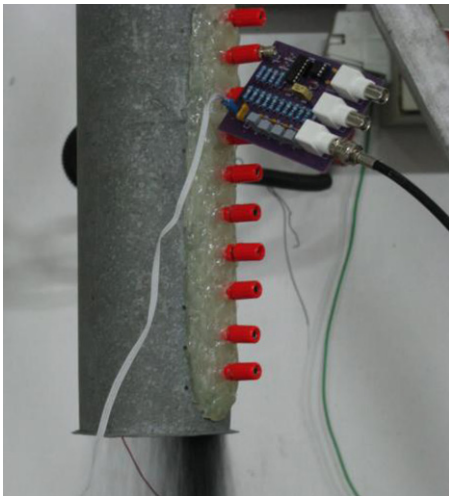

Figure 2: Electrostatic sensors places with certain interval along the conveying pipeline.

2. Description of the test setup

The test rig used in this research consists of a funnel, conveying pipe, valve and container (Figure 1). The solid materials available in the funnel drop down by gravitational force through the conveying pipe into the container. The valve placed on top of the conveying pipe controls the amounts of solid particles that drop from the funnel. After passing through the conveying pipe, the solid particles are gathered in the container.

Electrostatic sensors are placed at the end of the conveying pipe. Ten (10) places are envisaged for placing electrostatic sensors. These ten points are located at certain intervals along the conveying pipe (Figure 2). The distance between each two adjacent sensors is 2.5 cm.

The solid particles are plastic beads with an average size of 3 mm, which fall from the funnel on top due to gravitational force. The distance from the valve to the place where the electrostatic sensors are installed is about 1.4 m (a schematic of the test rig is shown in Figure 3). After the particles fall into the container, they can be sent back to the funnel using a vacuum pump.

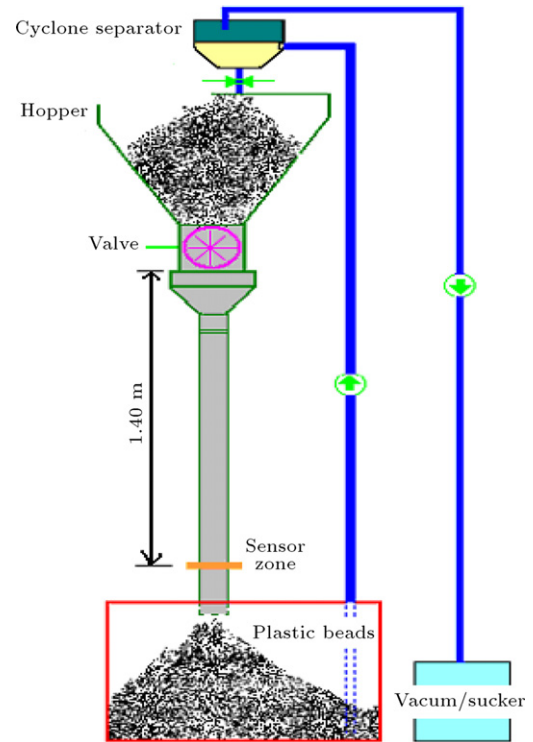

Figure 3: Schematic of solid/air test rig.

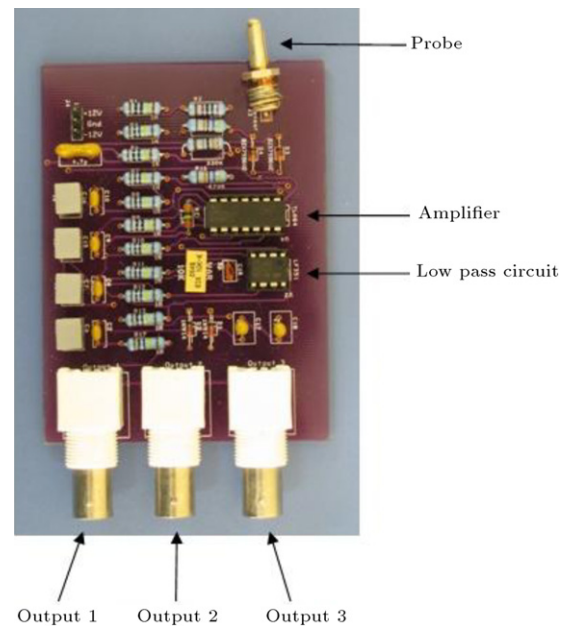

Figure 4: Electrostatic sensor consists of probe and its associated amplifying board.

Each electrostatic sensor is composed of a sensing probe which is sensitive to the electrostatic charge of the solid particles. There is also an electronic board for amplifying and low pass filtering of the signal obtained from the sensing probe [6]. The sensor probe and associated electronic board are shown in Figure 4.

As shown in Figure 4, the probe is a rod electrode, which has a length of about 2 cm and diameter of about 3 mm.

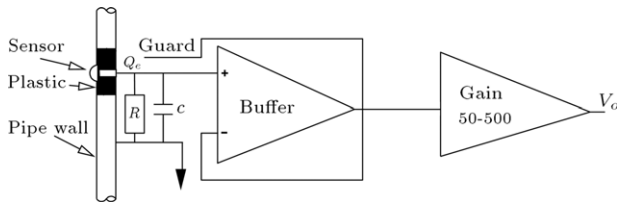

Figure 5: Detail of electrostatic sensor.

A block diagram of the electrostatic sensor is presented in Figure 5 [7].

The sensor probe and adjacent pipe create a capacitor. As can be seen in this figure, the sensor probe is one of the capacitor conductors. There is a plastic ring between the sensor probe and the adjacent pipe. This plastic ring acts as capacitor insulation. The pipe acts as the other conductor of the capacitor. This capacitor (between the sensor probe and the pipe) is placed in parallel with another capacitor and a resistor. When a solid particle with an electrostatic charge passes beside the sensor probe, it induces some charges to the sensor probe. For example if the particle has some positive charge, it induces some negative charges to the sensor probe. This is due to the interaction of negative charges and the distraction of positive charges. Then, the induction of some electrostatic charge in the sensor probe causes the creation of voltage in it, compared to the adjacent pipe (due to capacitance effect of sensor probe).

This voltage can be sensed by the electronic board. Since the charges induced in the capacitor are very minor, the electronic sensor that can sense the voltage induced should draw very small current from this capacitor. This is why the sensor probe is connected to the input of an op-amp drawing (very minor currents). To measure the induced voltage without taking a large current from sensor probe, the pipe is connected to ground and the sensor probe is connected to a one-to-one amplifier (voltage follower made from op-amp). The role of this one-to-one amplifier (voltage follower) is to provide the same voltage as the sensor probe and to amplify the current. Also, because the voltage created in the electrostatic sensor is very small, after passing this voltage through the voltage follower, this voltage is amplified further using another op-amp.

The outputs of the sensors are transferred to an analog/digital convertor (Dewetrons measuring pod DEWE-41-T-DSA) and after digitizing, the output of this analog to digital convertor will be transferred to a computer for calculating the velocity of the solid particles using the cross correlation method. The sampling time of this analog to digital convertor is set to 0.001 s. Sampling time should be small enough so that enough samples are gathered to identify the change of electrostatic signal due to the passage of solid particles. Also, if very small sampling time is selected, then, for getting good results from cross correlation, we need to have many samples, which increase the number of calculations for performing cross correlation. For example, if we divide the sample time by two, the required number of multiplications for performing cross correlation in an on-line mode increases four times. Therefore, it is important to select a suitable sample time for obtaining good results from cross correlation and, at the same time, not to increase the number of calculations unnecessarily. The reason for this selection is that, since we expect the velocity of solid particles to be less than 5 m/s (by assuming that the solid particles are falling by gravity and by ignoring the friction between these particles and the air/pipe wall) and, as the minimum distance between probes of two electrostatic sensors is 2.5 cm, it takes less than 0.005 s

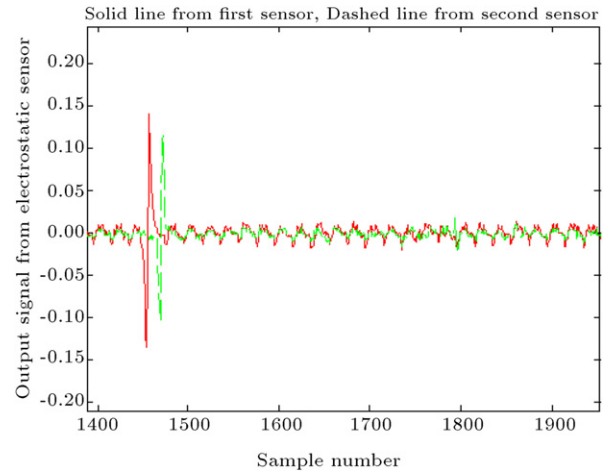

Figure 6: Typical graphs of electrostatic sensor signals showing the spikes due to passage of solid particle.

for a solid particle to reach from the first to the second sensor. So, the time required for solid particle to reach from the first to the second sensor (with distance of 2.5 cm) is equivalent to 5 sample times. Therefore, 0.001 s sampling time can be considered a good choice compared to the minimum time of 0.005 s needed for solid particles to reach from the first to the second sensor.

For applying the cross correlation method, the outputs of two sensors are compared. Each two electrostatic sensors chosen for applying the cross correlation method are placed with a certain distance between them along the conveying channel. The passing of solid particles causes a spike in the output of both sensors. Since the second sensor is placed at a certain distance from the first sensor along the channel, when a solid particle passes through the channel, first, it reaches the first sensor and then, with a time delay, it reaches the second sensor. Therefore, similar spikes are generated in the output of these sensors with a time delay between the spikes. This time delay is equal to the time required for a solid particle to reach from the first to the second sensor. In Figure 6, the output signals of two sensors obtained from the test rig have been shown. As can be seen, there are similar spikes in outputs from these sensors.

3. Modelling electrostatic sensors

In this section, the basis of operation of electrostatic sensors is explained. As explained, an electrostatic probe consists of a metallic element which is placed in the vicinity of air/solid fluid. For example, it can protrude into a pipe wall where solid/air is passing through. If there is a solid particle with electrostatic charge in the vicinity of the electrostatic probe, then, an electrostatic charge is induced in the metallic element of the electrostatic probe. The magnitude of this induced charge depends on the electrostatic charge of the particle and the distance from the particle to the probe.

Solid particles in solid/air fluid normally have some electrostatic charge, mostly due to friction, between the particles and the pipe. Assuming that the electrostatic charge of a solid particle is q , then, the electric field generated by this charge is as follows:

$$E = \frac{q}{4\pi\epsilon r_i^2}. \quad (1)$$

Since the probe of the electromagnetic sensor is made of metal and since this probe is insulated from the main pipe (to form a capacitor, as explained in Section 3 above), the electric field provided by the charged solid particle induces some electrostatic charge in the sensor probe. Since the solid particle is moving, when it is very near to the electrostatic sensor, it induces more electrostatic charge. The amount of electrostatic charge induced on the sensor probe is as shown by the relation below [8]:

$$q' = \frac{a}{b + [v(t - t_0)]^2}. \quad (2)$$

In this equation, v is the velocity of the solid particle and t is the time. Also, t_0 is the time during which the solid particle passes across the electrostatic sensor, and q' is the induced charge on the electrostatic sensor. Parameters a and b depend on the shape of the electrostatic sensor (its diameter), amount of solid particle charge and the distance between the solid particle and the electrostatic sensor (at nearest point).

Since electrostatic sensors form a capacitor with the adjacent pipe, the current of this capacitor is as follows:

$$i = \frac{dq'}{dt}. \quad (3)$$

Since this current is passing through the resistor (shown in Figure 5), the voltage produced across the resistor is equal to:

$$V = -iR = -R \frac{dq'}{dt} = \frac{2Rav^2(t - t_0)}{\{b + [v(t - t_0)]^2\}^2}. \quad (4)$$

As the resistor in Figure 5 is placed in parallel to the capacitor (electrostatic sensor), the current passing through the resistor is equal to the current of the capacitor multiplied by -1 . This is why (in the above relation) $V = -iR$. The shape of the output signal from the electrostatic sensor predicted by Relation 5 matches the shape of the signal from the electrostatic sensor obtained from experimental results (Figure 6). In this signal, there is a negative peak in the signal followed by a positive peak when a solid particle passes the electrostatic sensor.

4. Cross correlation

The cross correlation of two different signals, $x(t)$ and $y(t)$, is defined as follows [9,10]:

$$z(\tau) = \lim_{T \rightarrow \infty} \frac{1}{T} \int_0^T x(t)y(t + \tau) \quad (5)$$

$z(\tau)$ specifies how much signal $x(t)$ correlates to $y(t + \tau)$. In other word, it specifies how much $x(t)$ is similar to $y(t)$ while $y(t)$ is shifted in time by τ . If these two signals are more similar when the y is shifted in time by τ_{\max} , then, $z(\tau)$ will have a maximum when $\tau = \tau_{\max}$. $x(t)$ can be considered the signal from the first sensor and $y(t)$ as the signal from the second sensor in this application.

As shown in the previous section, the signal from the second sensor is similar to the signal from the first sensor, which is delayed in time. This time delay is equal to the time required by the solid particle to reach from the first to the second sensor and is equal to the distance between the sensors divided by the velocity of the solid particles.

If we calculate the cross correlation of the signals obtained from two sensors as a function of τ and if we obtain the time when maximum cross correlation occurs (τ_{\max}), then it can be assumed that τ_{\max} is equal to the time delay between the

two signals. After calculating τ_{\max} and by knowing the distance between two sensors, the speed of the air/solid fluid can be calculated as follows:

$$V = \frac{D}{\tau_{\max}}, \quad (6)$$

where V is the velocity of the air/solid fluid, D is the distance between the two sensors and τ_{\max} is the time when maximum cross correlation occurs.

In a real situation, the signals are sampled at regular intervals of 0.001 s. Therefore, we need to define the cross correlation of discrete signals as follows [5]:

$$z[m] = \lim_{T \rightarrow \infty} \frac{1}{T} \sum_{n=0}^T x[n]y[n+m] \quad (7)$$

In the above formula, $x[n]$ is the n th sample of signal $x(t)$. Also, since, as per this definition, infinite numbers of samples are required for performing cross correlation, it is not possible to calculate cross correlation in real time (on-line mode, while the sampling from the signals is taking place). Therefore, we need to define a modified version of cross correlation as follows [11]:

$$z[m] = \frac{1}{L} \sum_{n=0}^L x[n]y[n+m]. \quad (8)$$

In this modified cross correlation, instead of having infinite numbers of sampled signals, we calculate the cross correlation by multiplying the latest collected samples of signals. In other words, we select a window of L samples from signal $x[n]$ and multiply it with the same number of samples from $y[n]$, when the signal $y[n]$ is shifted in time by m . The value of m is also selected, based on what is the maximum shift in the peak of the signal between signals $x[n]$ and $y[n]$. For example, in this case, we expect the speed of particles to be below 5 m/s (since, if we consider the particles accelerate due to gravity and there is no friction with air, then the falling of particles from a height of 1.4 m will result in a speed of about 5 m). Then, for example, in cases where the distance between the two electrostatic sensors is 5 cm, we expect it to take less than 0.01 s (10 ms) for the particle to reach from one sensor to the other. Since the sampling time is 0.001 s (1 ms), we expect the signal from the second sensor to be similar to the signal from the first sensor with a time shift of, maximum, 10 ms (10 samples). So, we select m from 0 to 11, in this case, and expect the peak in cross correlation to occur when m is less than or equal to 10.

Also, as can be seen in Figure 6, when a particle passes across the electrostatic sensor, there is a negative peak followed by a positive peak in the signal from each sensor. The total duration of both negative and positive peaks is about 30 samples. Therefore, the length of window L can be considered to be in the same magnitude (e.g. 50 in this case to cover 30 samples). When a particle passes near the electrostatic sensor, a peak occurs in the signal of both sensors. At other times, when there is no particle passing near to the electrostatic sensors, the signals of both sensors are some values near to zero (refer to Figure 6). Therefore, when calculating cross correlation using relation 8 to detect the time shift between the signals from two sensors, it is better to find the peak in the signal from one sensor and then apply the cross correlation method. This idea is especially important when cross correlation is going to be applied for on-line flow measurement, as we do not get good results from cross correlation when signals of two sensors are near to zero, due to an absence of solid particles at that time. Also, we will not waste processing capacity by cross correlating almost zero values.

To consider this point, the software for performing cross correlation is written in such a manner that it senses whether there is a peak value in the window of signal $x[n]$. If there is a peak value in this window, then it performs cross correlation between signals $x[n]$ and $y[n]$ and calculates the speed of particles. As there are several peaks in the signals, due to the passage of solid particles, skipping some samples does not affect on-line measurement of solid particle speeds. Since the duration of sampling is very short, cross correlation can be performed in other windows of the signal without affecting the result. For example, if one window of the signal is collected in a period of 10 ms, then the next window of 10 ms might have a peak and, as the flow rate is not changing so fast, not computing for 10 ms does not affect the overall flow measurement.

In order to find τ_{\max} and the velocity of air/solid, accordingly, using modified cross correlation, we consider L large enough so that both spikes in the signals are included in calculating the modified cross correlation and so that we have enough samples for finding the peak in the cross correlation signals. For example, if we expect the velocity of solid particles to be, maximum, 5 m/s and the distance between the sensors is 2.5 cm (0.025 m), we should expect that the peak in the cross correlation curve will occur at 0.005 s, as calculated below:

$$\tau_{\max} = \frac{D}{V} = \frac{0.025}{5} = 0.005 \text{ s.} \quad (9)$$

Then, since the sample time of the Analog to Digital convertor is 0.001 s (1 ms), in this case, we expect that the cross correlation happens when $n = 5$. Therefore, if we select, for example, the last 40 samples ($L = 40$), then, we somehow make sure that the peak will occur in the cross correlation calculated using $L = 4$.

To have a better illustration of cross correlation results, the computed cross correlation is shown in Figure 7. As specified in this figure, the cross correlation has a peak at 32 sampling points which is equal to 0.0032 s (sampling time 0.001 s). In other sections of this envelope, cross correlation tends to approach zero, since, except for similar spikes in the outputs, the two signals are uncorrelated signals with an average of zero.

For performing the cross correlation method defined above, a software code has been written using MATLAB software. For performing this code, the necessity of applying cross correlation in on-line measurements has been considered. Therefore, at each time, this code is only using the sampled data of electrostatic sensors in past time (the time before the current time).

5. Results

In Figure 7, the speed of the solid/air fluid computed by the cross correlation method is plotted in cases where the distance between sensors is 5 cm. Here, the average speed of the solid/air fluid over the time is 3.1295 m/s.

As shown in Figure 2, sensors can be placed in any 10 locations allocated for them in the end section of the conveying pipe. Therefore, we can choose to have two sensors with different distances between them (i.e. 2.5, 5, 7.5, . . . , 22.5 cm).

For evaluating the correctness of the cross correlation method, we compare the results of different tests in which sensors are located with various distances between them. For performing this comparison, the average speed of the air/solid fluid in each case is computed.

In Figure 6, the average speed of the air/solid is plotted against the distance between sensors. It can be seen that the computed speed of the air/solid is similar in various cases where

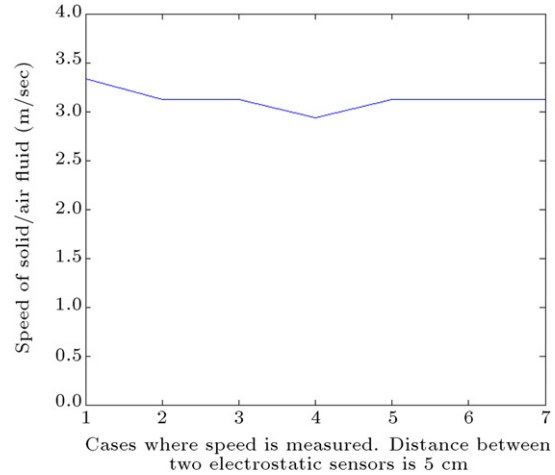

Figure 7: Computed speed of air/solid fluid when the distance between sensors is 5 cm.

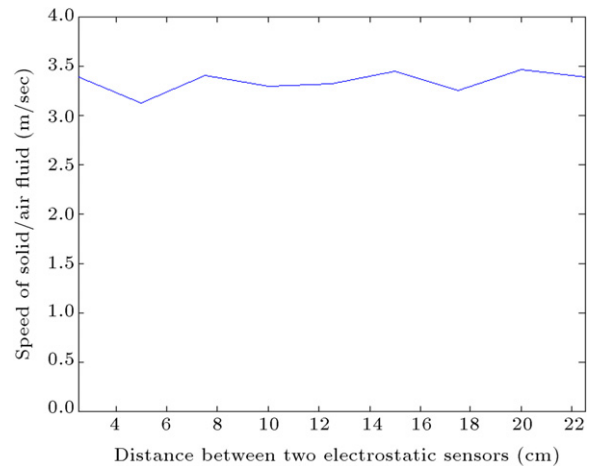

Figure 8: Average speed of calculated air/solid fluid versus the distance between sensors in the test setup.

the sensors are placed with different distances between them. This issue (similarity of results) is a proof of the correctness of the cross correlation method. The average speed of air/solid fluid in all tests with different distances between sensors is 3.3940 m/s. This value is very near to the computed speed when the distance between sensors is 5 cm (3.1295 m/s).

To better illustrate the cross correlation results, the computed cross correlation at a certain time is plotted in Figure 6. In this case, the sensors are 5 cm apart.

Also, the computed cross correlation is plotted in Figure 8, when the distance of sensors is 10 cm.

In Figure 9, the peak appears in 17th discrete time (0.017 s). Considering a distance of 5 cm, the speed is 2.94 m/s, while, in Figure 10, the peak occurs at 34th discrete time (0.034 s). Considering a distance of 10 cm, the speed is also 2.94 m/s, in this case.

Figure 10 shows the variance of speed measurement at various distances between sensors. Although the variance of speed measurement is less than 0.2 m/s for all cases, the variance is particularly very small when the distance between sensors is 5 cm. So, based on this figure, it is advisable to put the sensors at the distance of 5 cm as shown in Figure 11.

To have a better vision of the signals obtained from electrostatic sensors, the outputs of both electrostatic sensors

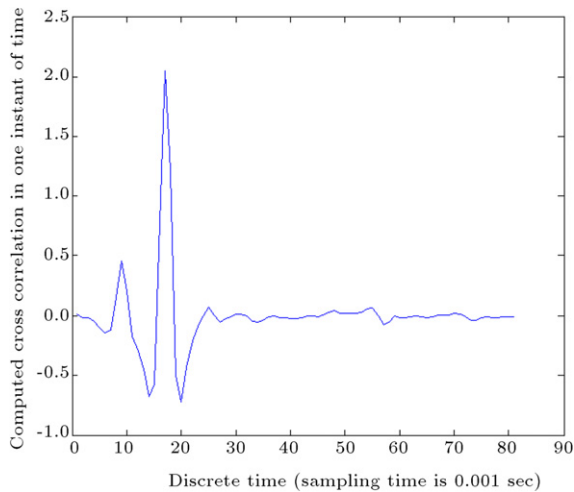

Figure 9: Typical cross correlation between the two signals when the distance between sensors is 5 cm.

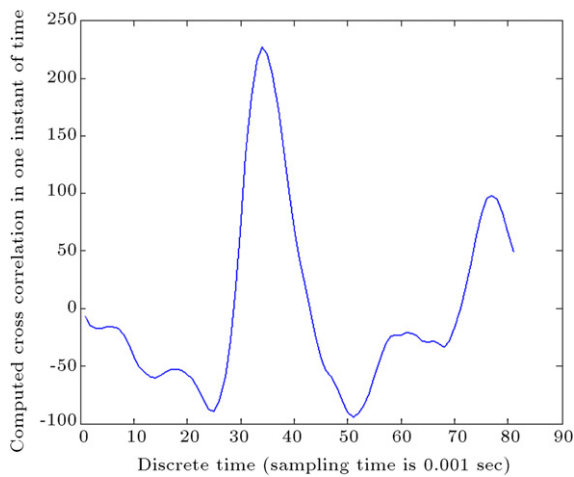

Figure 10: Typical cross correlation between the two signals when the distance between sensors is 10 cm.

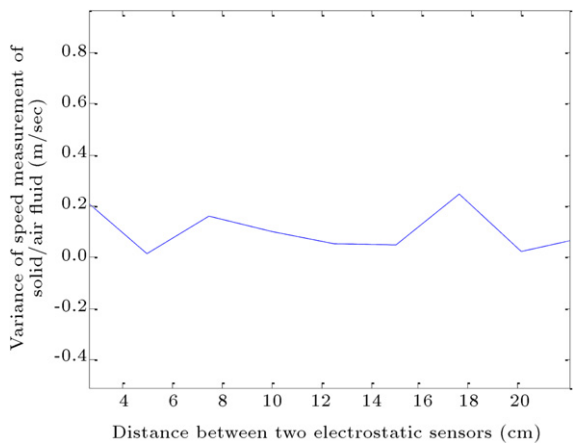

Figure 11: Output signals of electrostatic sensors when distance between sensors is 2.5 cm.

are shown in two cases where the distance between sensors is 2.5 and 15 cm (Figures 12 and 13).

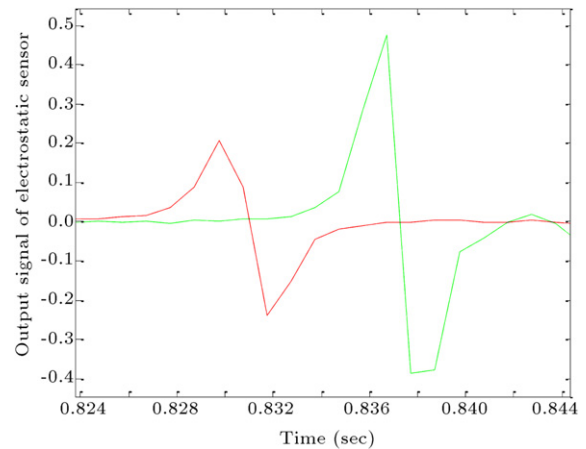

Figure 12: Output signals of electrostatic sensors when distance between sensors is 2.5 cm.

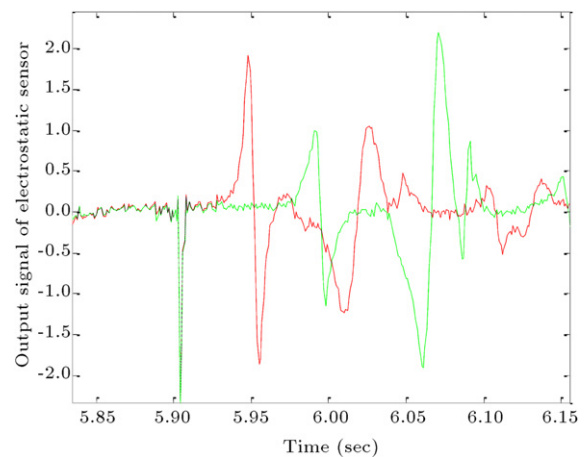

Figure 13: Out signals of electrostatic sensors when distance between sensors is 15 cm.

6. Conclusion

In this paper, we investigate the cross correlation method in solid/air flow measurement. First, we introduce a modified version of the cross correlation method which can be used for on-line flow measurement purposes. Then, this modified version of cross correlation is implemented using Matlab software. Finally, this implementation of modified cross correlation is used with the actual values gathered from a test rig, and it is demonstrated that the modified version of cross correlation can be used for on-line flow measurement purposes.

References

- [1] Ma, J. and Yan, J. "Design and evaluation of electrostatic sensors for the measurement of velocity of pneumatically conveyed solids", *Measurement and Instrumentation*, 11, pp. 195–204 (2000).
- [2] Massen, R. "Some remarks on selection of sensors for correlation velocity measurement systems", *Sensors and Actuators*, 3, pp. 221–231 (1982).
- [3] Rahmat, M.F. and Kamaruddin, N.S. "An electrodynamic sensor for electrostatic charge measurement", *International Journal on Smart Sensing and Intelligent Systems*, 2(2), pp. 200–212 (2009).
- [4] Rahmat, M.F. "Instrumentation of particle conveying using electrical charge tomography", Sheffield Hallam University (1996).
- [5] Peng, L., Zhang, Y. and Yan, Y. "Characterization of electrostatic sensors for flow measurement of particulate solids in square-shaped pneumatic conveying pipelines", *Sensors and Actuators*, 141, pp. 59–67 (2008).

- [6] Jawad, H.T. "Non-intrusive methods of velocity measurement in pneumatically conveying solid particles using electrostatic sensor", Thesis in Electrical engineering, University Technology Malaysia, Johor Bahru (2010).
- [7] Rahmat, M.F. and Kamaruddin, N.S. "Application of fuzzy logic and electrodynamic sensors as flow pattern identifier", *Sensor Review*, 32(2), pp. 123–133 (2012).
- [8] Krabicka, J. and Yan, Y. "Finite-element modeling of electrostatic sensors for the flow measurement of particles in pneumatic pipelines", *IEEE Transactions on Instrumentation and Measurement*, 58(8), pp. 2730–2736 (2009).
- [9] Oppenheim "Digital Signal Processing", Pearson (2002).
- [10] Jung, S.H., Kim, J.S., Kim, J.B. and Kwon, T.Y. "Flow-rate measurements of a dual-phase pipe flow by cross-correlation technique of transmitted radiation signals", *Applied Radiation and Isotopes*, 67, pp. 1254–1258 (2009).
- [11] Arattano, M. and Marchi, L. "Measurements of debris flow velocity through cross-correlation of instrumentation data", *Natural Hazards and Earth System Sciences*, 5, pp. 137–142 (2005).

Hossein Seraj obtained his B.S. and M.S. degrees from Sharif University of Technology, Tehran, Iran, in 1997 and 1999, respectively, in the field of control

and instrumentation. Currently, he is a Ph.D. degree student at University of Technology Malaysia. He also has several years of experience in the industrial application of instruments.

Mohd Fua'ad Rahmat obtained his B.S. degree from Universiti Teknologi Malaysia in 1989, his M.S. degree from Sheffield University, UK, in 1993, and his Ph.D. degree from Sheffield Hallam University, UK, in 1996. He is currently faculty member and head of the Electrical Engineering Department at Universiti Teknologi Malaysia. He was awarded the Hinckley Prize for Outstanding Academic Achievement.

Marzuki Khalid obtained a B.S. degree in Electrical Engineering from Southampton University, UK, in 1983, an M.S. degree in Control Systems from Cranfield Institute of Technology, UK, in 1986, and a Ph.D. degree in the area of Neuro-Control from the University of Tokushima, Japan, in 1994. He is currently a faculty member in the Electrical Engineering Department at Universiti Teknologi Malaysia, where he has also served as research counselor. He was awarded the "International Exchange Award for Outstanding Research Accomplishment" in 1992 and served as Director of the Malaysia–Japan center. He also worked as the director for the Centre of Artificial Intelligence and Robotics (CAIRO) in the same institute.