

M2M Communication in Virtual Sensor Network for SHAAL

Zubair Khalid^{a,b*}, N. Faisal^a, Rahat Ullah^{a,b}, Hashim Safdar^{a,b}, Wajahat Maqbool^a, S. Zubair^a, A. S. Khan^a

^aUTM-MIMOS Center of Excellence, Faculty of Electrical Engineering, Universiti Teknologi Malaysia, 81310 UTM Johor Bahru, Johor, Malaysia

^bDepartment of Electrical Engineering, Federal Urdu University of Arts Science & Technology, G7/1-Islamabad, Pakistan

*Corresponding author: engr.zubairkhalid@yahoo.com

Article history

Received :24 May 2013

Received in revised form :

8 October 2013

Accepted :15 October 2013

Graphical abstract

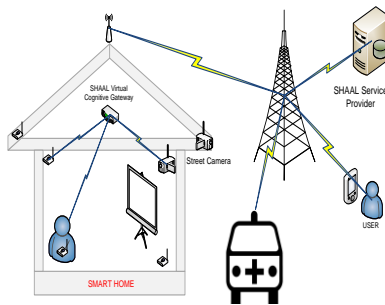

Abstract

Machine-to-Machine (M2M) communication has led to a new paradigm of Internet of Things (IoT). The future of M2M communication in smart home lies in the aggregation and allocation of resources and service provisioning of diverse applications using different radio technologies. M2M communication may operate on the virtual sensor network to provide independent applications running on heterogeneous network simultaneously. M2M is going to play a major role in the area of Smart Home and Ambient Assisted Living (SHAAL) providing assistance to the elderly people with smart sensors that monitor the home environment and provides aid health monitoring to human requiring medical assistance. The current state of the art frameworks are dedicated to specific applications with the support of single radio network with limited service provisioning options. However, in order to fully exploit the resources in this paper we present a service provisioning framework realization of M2M in virtual sensor network for SHAAL, which allows independent parties to work together in a secure and reliable manner. In addition to this, the framework is designed to include benefits of Service Oriented Architecture (SOA) and Resource Oriented Architecture (ROA) along with the use of different low power, low data rate protocols. A middleware is used as a platform to link the underlying virtual networks with various applications. The network virtualization approach is adopted to design an efficient middleware framework that can effectively discover and manage the underlying network resources and provide services at home gateway. The framework will be used as the basis for the development of the SHAAL networked system.

Keywords: M2M communications; SOA; virtual sensor network; middleware

© 2013 Penerbit UTM Press. All rights reserved.

1.0 INTRODUCTION

M2M is a paradigm that enables machines to communicate with each other with little or no human intervention. M2M is based on commonalities and ubiquitously used technologies such as Wireless Sensor Networks (WSN), mobile network and the internet. The main attribute of M2M communication is self-management, self-organizing, low power, low cost and self-healing [1] as M2M ensures Quality of Service (QoS), so dealing with medical data that needs to be transmitted in real time without error can be achieved using M2M technologies and devices.

Devices with low data rate are being connected to the Internet in a massive number. Approximately, 50 billion devices would be connected by 2020 and this is more than the number of people on earth [2]. On the other hand, the requirements for high data rate such as video and multimedia services are getting essential in future M2M communications.

SHAAL platform can facilitate many elderly people who are facing health complications mainly due to their cognitive decay, hearing and vision loss and lack of physical strength. In the U.S.A only about 80% of those over 65 years are living with at least one chronic disease [3]. Lately, most of the latest progresses to increase independence of elders at home are linked to the advancement of sensor technologies, software and hardware

architectures, remote monitoring, low power network protocols and devices.

In SHAAL large number of such devices will be used to monitor every day activities for supporting independent living of elderly people, continual assessment of health and cognitive process [3]. To cope with such situation it would be necessary for the heterogeneous networks to support interconnections of multiple applications and services so as to ensure QoS. Furthermore, to meet the challenges multi radio technologies need to play their part and support versatile services in WSN. Prominent radio technologies that are commonly used in WSN include IEEE 802.15.1 (Bluetooth), IEEE 802.11 (WiFi), IEEE 802.15.4 (ZigBee), cellular, 3G/4G [4],[5],[6].

In order to efficiently use multiple radios, network virtualization provides us the opportunity to efficiently administrate over the resources and services. Network virtualization is gaining immense attention in the communication systems and networks. Furthermore, it can facilitate networking operational tasks including managing inter portability, device management, security management, power management, service management and resource management.

Sensor virtualization is another approach of programming the sensor that is by injecting fresh code into each node dynamically and changing its attributes, using this approach an

error correction scheme is presented by reference [7]. Virtual Sensor Networks (VSN) middleware can also be based upon Fuzzy logic, as proposed by [8].

Network virtualization in WSN focuses on algorithms and protocol that links with the various underlying WSNs for the formation, merging, splitting, adding and deleting nodes as proposed in [9]. Examples of middleware using virtual machines are Maté and ASVM [10],[11]. They are more application specific and the size of the assembly code to be transmitted for reprogramming has been reduced.

Furthermore, in order to realize sensor network virtualization; the role of middleware has to be enriched in order to provide a flexible high level interface to the application developers by providing abstraction to the lower layer.

There are two approaches of the middleware; an approach that provides a programming abstraction and the approach that provide programming support [11]. A number of middleware has been designed through different approaches that include database-inspired approach, event-based or message oriented approach, modular based approach, application based and virtual machine based approach [11].

Context aware middleware framework proposed in [12] is an attempt to minimize the ambiguity in health care applications. I-Living [13] takes into account multi radios is the closest to our framework with respect to the use of multi radios for the assistance of elderly people at home however, it doesn't incorporate the service provisioning mechanism. Reference [9] shows the intended M2M scenario for health care with intelligent sensors and middleware approach however it is application specific and concentrates only on cardiac attack.

The frameworks for low power low data rate are proposed in [6],[4],[1],[14] and [5] they take into account multi radio technologies but don't incorporate the network virtualization in their proposed architectures. However, the framework proposed in [15] tries to fully exploit the virtualization but without considering the multiple Physical (PHY) and Medium Access Control (MAC) Protocols. Furthermore, it includes service provider ever time session is established that takes more time, energy and cost. A policy based framework for M2M communication is proposed by [15] but don't considers multi radio protocols.

To fully exploit the benefits of virtualization similar approach has been adopted by [10] and [16]. However, the proposed framework reduces the involvement of the service provider's core network. The use of service provider's infrastructure is based on the application and the location of the client, other contribution of the paper is that it uses different PHY and MAC protocols for sensor data transmission.

This paper proposes a M2M framework to fully benefit from the virtualization, focuses on the middleware for SHAAL that utilizes the prominent radio technologies. Sensor's data from different WSNs is managed on a single virtual smart home gateway. Moreover, it collaborates with service provider for the provision of services to clients when required. It also supports applications that require the services and resources offered by other wireless sensor networks.

The remainder of the article is organized as follows. Section 2 introduces SHAAL, Section 3 presents M2M standards, while section 4 elaborates the current low power radio technologies. Section 5 shows the proposed framework and design principles, and finally section 6 concludes the paper.

■2.0 DESCRIPTION OF SHAAL

Advancement in medicine, agriculture, transportation and living standards getting higher, are one of the major factors that

contribute to live longer and healthier living as compared to the previous generations. In fact, roughly 20% of the world's population will be age 60 or older by 2050 [3],[17]. Approximately 20% of the people on earth will be aged 60 or above by 2050 [17].

Increase in age brings several contests to the elders due to their cognitive decay, age-related diseases, along with limitations on the physical activities like vision and hearing.

There will be a rise in the health care costs as caregivers and clinicians will have to spend more time for the nursing elderly people. Therefore, the current model of caring is going to be strained as the aging population increases in the next few years.

To cater this problem, one of the important fields of remote sensing and monitoring is assisted living. Therefore, the proposed work currently concentrates on SHAAL. It does not only facilitate in monitoring and improving health of individuals, but also contributes in making them independent by increasing their safety, mobility, and public contacts. SHAAL works on the most thoughtful health risks among elders over the age of 60 that can be a fall, a stroke, heart attack, or some other disaster event.

SHAAL contribution in the health informatics domain has increased, facilitated by significant developments in the field middleware, IoT, virtualization of sensor networks and embedded devices. The proposed SHALL framework focuses on the challenges regarding service provisioning for ambient home care system, that monitors the everyday life of the elder or dependent people at home.

■3.0 STANDARDS OF M2M

Standardization is quite essential to move technology towards the market trends and to provide ground for future business with the essential knowledge for implementation.

The standard bodies are very carefully watching the progress in all relevant fields that have an influence on the M2M communication [14]. Virtualization and segregation of application of the sensor will help to develop the standard rapidly. Several standard organizations are working on the M2M standardization including the European Telecommunication Standard Institute (ETSI) technical Committee was created in January 2009 [13]. They are developing a set of M2M standard that provides end-to-end view and enables the combination and interoperability of several M2M systems [18]. ETSI completed the specification of the functional architecture for M2M communications [10]. Their work is evolving in providing end to end framework with general functional behavioral requirements. The standard body provides an end-to-end assessment. Furthermore, it also hides the complexities of lower layers from the application developer using middleware so that rapid developments and innovation in services can be achieved [1].

3rd Generation Partnership Project (3GPP) release 10, 11 and 12 particularly focused on the architecture, services, signaling and network improvement for Mobile Type Communication (MTC). Moreover, the focus is on MTC server and control plane having more Public Land Mobile Networks (PLMN). All the devices are connected to MTC server and communicate via one or more PLMN. 3GPP is working deeply on time tolerant, remotely managed secure small data transmission[14].

Telecommunications Industry Association (TIA) Committee TR50 is working on a new physical channel enhancement, MAC layer congestion and the flow control mechanisms. Furthermore, TIA is working on standard interface for monitoring and bi-directional communication for applications. They also look into the transport networks and the development of a smart device communications framework [19].

GSM Association (GSMA) is working on embedded module design, radio interfaces, network management, devices, authentication and services based on GSM. Furthermore, GSMA is working on particular applications, vertical market, such as automotive, health, utilities and consumer devices[4].

WFA promotes Wi-Fi in smart grid and health care. It is more application oriented and emphasizes on the smart grid, electrical equipment management and health care at homes and hospitals using 802.11 (Wi-Fi) as key wireless communication technology.

Institute of Electrical and Electronics Engineers (IEEE) is focusing on 802.16p (WiMAX) optimizing the air interface for energy efficient device transmission device authentication and small burst transmission. Furthermore, IEEE is working on 802.11, 802.15.1 and 802.15.4 for optimized air interface using sub-GHz spectrum.

China Communications Standards Association (CCSA) focus on mobile internet application in particular to the interfaces of hardware and location based services. They also explore on the data formats, IDs and security of WSN to be deployed on smart buildings and airports[4].

In M2M perspective, the vital research topic is how we can provide more security, flexibility, scalability and QoS for the health care applications. M2M virtualization is the key to success for service providers. To flexibly create multiple services based on the resourceful infrastructure, which can be achieved using middleware.

Standard bodies widely acknowledge the role of middleware. Most of the work has been done on particularly WSN.

Middleware with different attributes have been developed for gateway, servers and single node. Particularly, ETSI-TC on M2M standardization focuses on the service middleware layer, instead of underlying network transmission technologies. ETSI implements services on top of M2M gateway and terminals. In order to support a wide range of M2M applications[13].

■4.0 PHY AND MAC PROTOCOL FOR LOW POWER COMMUNICATION

In wireless communications a number of MAC protocols for low power, low data rate and short range communication are available. IEEE has defined PHY and MAC layer for short range low power and low data rate wireless communications. They are IEEE 802.15.1 (Bluetooth), IEEE 802.11 (WiFi), IEEE 802.15.4(ZigBee). They operate in 2.4 GHz band which is an ISM band using different channels, bandwidth, encryption, authentication and spreading techniques summarized in Table 1 [5],[20],[21],[6],[22].

Bluetooth offers less network latency in case of slave channel access compared to ZigBee. However, ZigBee offers much faster state change from sleep to active mode and new slave enumeration. In addition ZigBee offers better scalability, flexibility and reliability over Bluetooth [20]. In order to take full advantage of various wireless data transmissions, all devices at home using diverse protocols should be combined with a platform and managed by an independent entity such as a cognitive gateway.

Table 1 Low power access technologies

Standard	Bluetooth	Zig Bee	WiFi
IEEE spec.	802.15.1	802.15.4	802.11a/b/g
1 Frequency band	2.4 GHz	868/915 MHz - 2.4 GHz	2.4 GHz - 5 GHz
2 Max signal rate	1 Mb/s (Basic) 3 Mb/s (Enhanced)	250 Kb/s	54 Mb/s
3 Nominal range	10m	10 - 100 m	100 m
4 Number of RF channels	79	1/10 16	14 (2.4 GHz)
5 Channel bandwidth	1 MHz	0.3/0.6 MHz 2 MHz	22 MHz
6 Modulation type	GFSK	BPSK (+ ASK), O-QPSK	BPSK, QPSKCOFDM, CCK, M-QAM
7 Spreading	FHSS	DSSS	DSSS OFDMA
8 Cell Nodes	8	2-65000	2007

■5.0 SYSTEM ARCHITECTURE FOR SHAAL

The basic system architecture is depicted in Figure 1. The proposed SHAAL architecture is quite flexible to accommodate different devices in heterogeneous environment. Furthermore, seamless service provision is achieved in a flexible manner according to the location of the user.

In the proposed SHAAL architecture service providers can dynamically utilize multiple virtual sensor networks that coexist

without any problem. Different VSNs in SHAAL framework can function in isolation while providing end-to-end services on the underlying multiple network infrastructure [23].

The proposed SHAAL architecture system combines various sensors using different protocols and heterogeneous equipment. Several virtual sensor networks can operate without compromising on the QoS as shown in Figure 1, while using different protocols to provide services to the user.

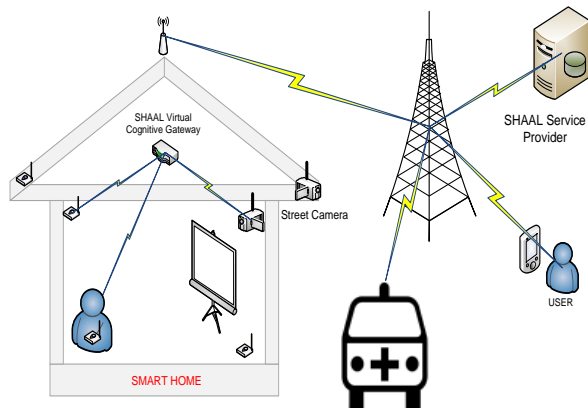

Figure 1 Network model

In the proposed architecture all the sensor nodes connect to the Virtual Cognitive Gateway (VCG), which is capable of altering VSN on the basis of current circumstances at home and health condition of the elder residents. VCG using different lower layer protocols ensures QoS for distinct scenarios.

The SHAAL service provider can also make the dynamic VSN on the basis of the sensor nodes shared by the VCG. Furthermore, it also allows the authenticated users to access sensor’s data from a remote location e.g. (Doctor gains access to health care data of residents).

5.1 SHAAL Virtualization

Virtualization creates an environment in embedded and sensor networks, by which efficient sharing of resources, services and networks is achieved this approach is best suitable for SHAAL. The goal of virtualization is to provide users with seamless access to the sensor data and efficient utilization of the resources [24],[25]. The core of the SHAAL virtualization lies in the middleware. One of the main objectives of the of the middleware supporting virtualization is to match the application needs in the best possible way, and to make sure that multiple heterogeneous sensor networks are managed in such a way that they ensure efficiency and quality.

Virtualizations of radio networks and sensors have wide application areas the paper focuses on the health care issues and smart home [25]. The technologies that support virtualization are tiny sensors of different types, diverse communication protocols (Zigbee, WiFi and Bluetooth) that have made possible to make a virtualized environment for wireless sensor networks. Software Defined Radio (SDR) is a collection of hardware and software technologies where all radio operations are implemented through software, the use of such technology allows different wireless radios to work together. SDR supports cellular, Bluetooth, and Zigbee protocols. Moreover, SDR gateway designs enable multicarrier, multiband products to communicate simultaneously with a number of protocols and frequencies.

5.2 SHAAL Middleware

Middleware is a software layer that glues the operating system and the applications of the system and the underlying network. In future there will be different types of devices with diverse applications running and they will collaborate with each other without knowing, what the topology. The topology may be peer to peer, client server or mesh. The role of the middleware is to provide an open platform for high level interface to the

application developers and open platform for interacting with the VSNs. Middleware hides the hardware and software details from the application [10].

Middleware is vital in the M2M virtual networks as applications can deploy, run and query without recognizing differences among the underlying networks and devices. Virtualization has been introduced in WSN with the goals to provide solutions to the limitations of the underlying network resources to serve various types of applications.

The proposed middleware enables the use of a single sensor data for multiple applications, dynamically creating different virtual sensor networks based on the application, priorities, events and QoS provision. The middleware enables virtual health care network to be treated differently than a virtual network responsible sensing temperature on the balcony.

In the proposed framework middleware resides at the home gateway and at the core network of the service provider. The middleware is responsible to manage and discover resources and services in the SHAAL network. Furthermore, in this technique the sensor node is unaware of the applications that are using it, and on the other hand applications are unaware of the sensors that are being used. The middleware is the heart of the proposed framework. It manages all the resources and creates services on the basis of the client request. Furthermore, it makes and breaks the virtual sensor networks and manages all the VSNs.

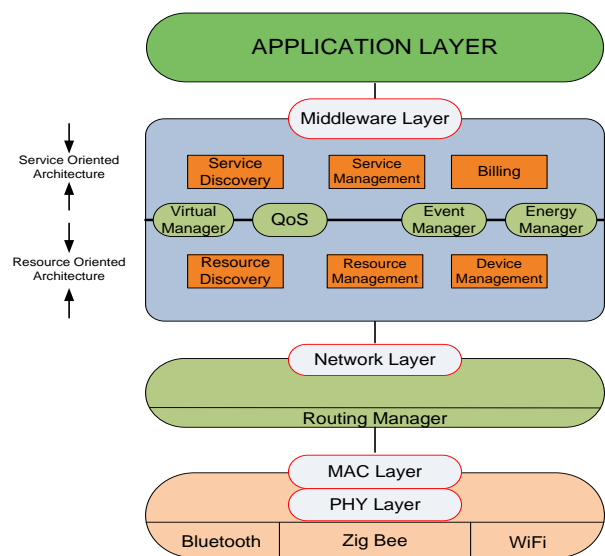

Figure 2 SHAAL Network model architecture

The proposed architecture utilizes the benefits of both the ROA and SOA. From the client’s prospective, the applications look at the sensor network as a service. SOA offers an appropriate balance between granularity, coupling, reusability, flexibility and simplicity. Moreover, one of the key tenets of SOA is the ability to update the components, add new services, replace current services, and reconfigure software accordingly.

Middleware based on SOA combines different resources and create services out of these resources. Figure 2 shows the protocol stack of the proposed SHAAL architecture. The proposed middleware is elaborated in Figure 2, and can be seen sandwiched between the higher layer and the lower layers. The application layer serves the client application, such as electrocardiographic (ECG) monitoring, fall detection, temperature and light measurement etc. The middleware contains the control functions to handle virtualization, QoS provisioning, services and resource

discovery. The network layer provides the routing protocol designed for low data rate energy aware devices. Finally, the MAC and physical layers which are comprised of multi radio low power technologies that provides flexible data transmission options in the SHAAL network.

5.3 Virtual Cognitive Gateway (VCG)

The entire home sensor nodes are connected to the VCG that is a single point contact capable of accepting data from different protocol standard in a transparent way, it is always powered and connected responsible for publishing, negotiation, provisioning, device management, and sensor management of the home network. Furthermore, discovery of available resources and operational services are also monitored. It is the brain of the smart home. VCG consists of a virtual home manager, routing manager, gateway interface, billing, device manager and security manager as shown in Figure 3. VCG does not involve service provider every time running the application that reduces the delay as well as billing of the client.

Virtual home manager manages all the VSNs of the home, and dynamically creates and breaks the virtual networks according to the application requirement, as well as the home environment. It manages the virtual networks considering data rate, communication range, power consumption, security, QoS and priorities of application scenarios.

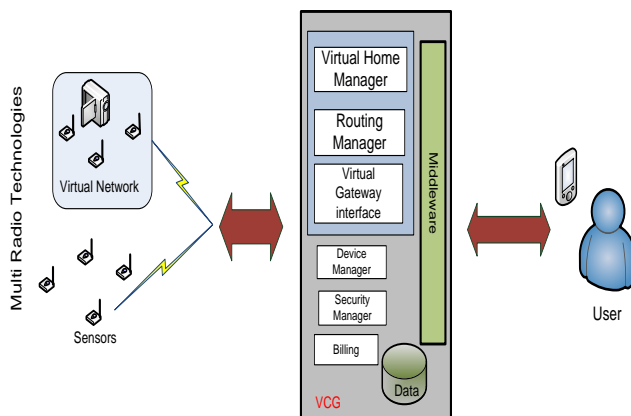

Figure 3 Virtual cognitive gateway design

VCG ensures QoS for the health care data and utilizes all its resources for safe and real time data transmission, on the other hand weather report and temperature sensing service can be set on the back burner as it can bear latency.

User connects to VCG through the gateway interface. The client is first authenticated by the security manager with the help of the database and then served. User at home can directly access the VCG without the intervention of the service provider that saves the overhead on the server as well as the billing at the client end.

VCG contains the data repository that keeps the record of all the sensor data and client IDs for authentication of user through security manager. VCG also keeps the record of the billing which home has to pay to the service provider. All the devices are managed through the device manager and middleware glues all the components together.

5.4 SHAAL Virtual Service Provider

SHAAL Virtual Service Provider (SVSP) is the agent offering smart services that can take care of elders at home. The SVSP core network consists of resource manager, service manager, energy manager, event manager, SHAAL Virtual Manager (SVM), QoS manager, SHAAL Database (SD), SHAAL Interface (SI) and billing as shown in Figure 4. SVSP can be connected to various VCGs of different homes and other Virtual Service Provider (VSP) through SHAAL interface. SVSP core network named as SHAAL Virtual Core Network (SVCN) that manages all the data traffic between the VCG and the remote client and also between VSPs.

SVM is responsible for session establishment, resource request and service provisioning. SI provides an interface to the VCG and remote users for the connectivity. The role of SD is to process queries put forward by SVM and the remote user. SD keeps the record of services, resources, SLA, devices, user authentication IDs, user contracts and billing record.

Moreover, SD retains records of all the traffic across the network. Health care data are critical so each reading is saved and made available only to the authenticated users for example hospital staff or Doctor. SVSP can also involve few home sensors e.g. Street camera or balcony temperature sensor that can facilitate other users. These sensors can be involved in a virtual sensor network established by SVSP to facilitate any public user e.g. Police department, when chasing a car on the street using home camera.

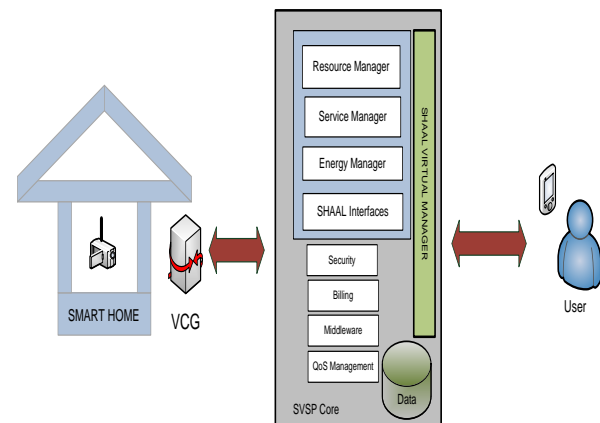

Figure 4 SHAAL service provider core network

The service provisioning in the proposed virtual network framework can be divided into four scenarios (a) User at home and accessing the home network resources only, (b) user at home accessing resources outside the home network, (c) user outside home and accessing home network and (d) User outside home accessing outside resources.

Scenario one: clinician at home accessing the home network resources only uses the following functions for the establishment of the session as shown in Figure 5.

User_Verification

This is used in the beginning, when a clinician connects to the VCG it is first authenticated using this function by the security manager with the help of database maintained at the VCG.

Service_Negotiation

Service negotiation starts between the application and the virtual home manager. This function looks into the requirements

of the user application, and accordingly makes virtual network for the service provision according to the user needs.

Service_Launch

After the successful negotiation of the *Service_Negotiation* function, virtual home network launches the service, and also monitors the service. If the service is not according to the quality it tries to prepare it, if failed, terminates the service and goes back to the *Service_Negotiation* function to launch the service again by making new virtual network that satisfies the QoS.

Obtain_Data

This function fetches the data from the sensor node and provides it to the User.

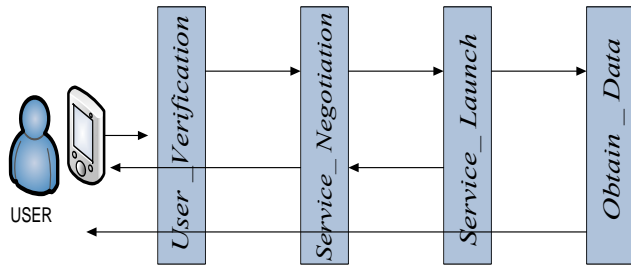

Figure 5 Function sequence in session establishment for scenario one

Scenario two: In this scenario clinician is at home accessing resources outside the home network in case the elder under observation is outside home. After the preliminary function of *User_Verification* at VCG if the *Service_Negotiation* function is unable to fulfill the user requirements, it requests the SVSP to look into the requirements. Service provision is now handled by SVM using the following functions.

SHAAL_Service_Negotiation

It looks into the application requirements and makes the virtual networks according to the user application requirements.

SHAAL_Service_Launch

After the successful negotiation of the *SHAAL_Service_Negotiation*, SHAAL VM launches the service, and also monitors the service. It is also responsible for the error free transmission to data to the user. Furthermore, if the service is not satisfying SLA it is terminated, and it calls back the function *SHAAL_Service_Negotiation* to negotiate again in order to satisfy the SLA.

SHAAL_Get_Data

This function gets the data from the virtual sensor network and provides it to the User shown in Figure 6.

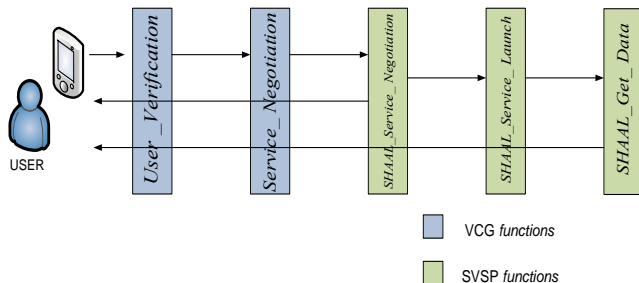

Figure 6 Function sequence in session establishment for scenario two

Scenario three: In this case clinician is outside the home and accessing home network shown in Figure 7. The clinician directly connects to SVSP core and after the *SHAAL_User_Verification* function, SHAAL interface connects to the home VCG and the process of scenario one starts by the *User_Verification* again.

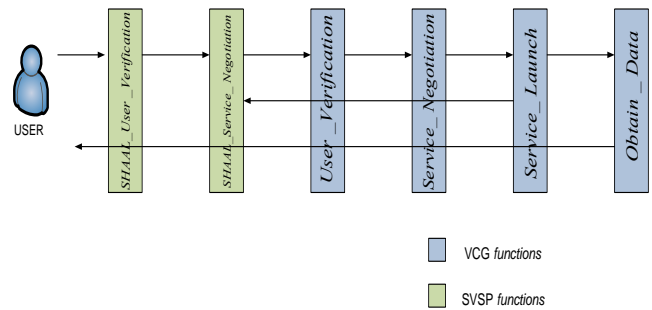

Figure 7 Function sequence in session establishment for scenario three

Scenario four: In this scenario clinician is outside the home and also accessing a sensor network of elder person outside the home shown in Figure 8. The user directly connects to SVSP core and doesn't connect to the home gateway. It begins with *SHAAL_User_Verification* function, and follows the procedure by calling the functions of *SHAAL_Service_Launch* and *SHAAL_Get_Data*. SHAAL interface connects to the home VCG. And the process of scenario one starts by the *User_Verification* again.

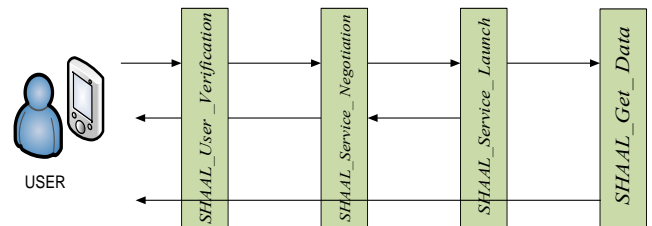

Figure 8 Function sequence in session establishment for scenario four

6.0 CONCLUSION

The presented M2M system architecture for SHAAL provides adaptability, scalability and flexibility required by the smart homes in order to assist elderly people. Furthermore, the expected results of the framework will reduce the cost in a great deal and increase the robustness and flexibility of the system. Multiple network protocol compatible architecture will improve system capacity and supports heterogeneity offered by the devices and the networks. Moreover, middleware will ensure QoS, mobility, security with the wide range of verity of choices to make.

In addition, SHAAL architecture takes benefits from both service-oriented architecture and resource-oriented properties for service provisioning the user at home needs not to involve service provider every time running an application. As a part of future work, we will be developing a testbed, based on the implementation of proposed system components that will validate the proposed work.

Acknowledgement

The authors would like to thank UTM-MIMOS Center of Excellence in Telecommunication Technology and Research Management Center, Universiti Teknologi Malaysia and Ministry of Higher Education (MOHE), Malaysia.

References

- [1] Y. Zhang, R. Yu, S. Xie, W. Yao, Y. Xiao, and M. Guizani. 2011. Home M2M Networks: Architectures, Standards, and QoS Improvement. *Communications Magazine, IEEE*. 49: 44–52.
- [2] I. Bojic, G. Jezic, D. Katusic, S. Desic, M. Kusek, and D. Huljenic. 2012. Communication in Machine-to-machine Environments. in *Proceedings of the Fifth Balkan Conference in Informatics*. 283–286.
- [3] P. Rashidi and A. Mihailidis. 2013. A Survey on Ambient Assisted Living Tools for Older Adults. *IEEE Journal of Biomedical and Health Informatics*. 17: 11–2.
- [4] J. W. Min Chen. 2012. Machine-to-Machine Communications: Architectures, Standards and Application. *KSII Transactions on Internet and Information System*. 6.
- [5] M. Starsinic. 2010. System Architecture Challenges in the Home M2M Network. In *Applications and Technology Conference (LISAT), 2010 Long Island Systems*. 1–7.
- [6] A. Coronato, G. De Pietro, and G. Sannino. 2010. Middleware Services For Pervasive Monitoring Elderly and Ill People in Smart Environments. In *Information Technology: New Generations (ITNG), 2010 Seventh International Conference on*. 810–815.
- [7] E.-N. Huh. 2013. An Efficient Model for Smart Home by the Virtualization of Wireless Sensor Network. *International Journal of Distributed Sensor Networks*.
- [8] M. Oosterom and R. Babuska. 2000. Virtual Sensor for Fault Detection and Isolation in Flight Control Systems-Fuzzy Modeling Approach. In *Decision and Control, 2000. Proceedings of the 39th IEEE Conference on*. 2645–2650.
- [9] Y. K. Seung Hwan Shi, R. Rim Haw. 2011. Intelligent M2M Network Using Healthcare Sensors. *Network Operations and Management Symposium (APNOMS), 2012 14th Asia-Pacific*. 1–4.
- [10] L. Sarakis, T. Zahariadis, H.-C. Leligou, and M. Dohler. 2012. A Framework For Service Provisioning In Virtual Sensor Networks. *EURASIP Journal on Wireless Communications and Networking*. 1–19.
- [11] S. Hadim and N. Mohamed. 2006. Middleware: Middleware Challenges and Approaches for Wireless Sensor Networks. *Distributed Systems Online, IEEE*. 7: 1–1.
- [12] N. Roy, G. Pallapa, and S. K. Das. 2007. A Middleware Framework for Ambiguous Context Mediation in Smart Healthcare Application. In *Wireless and Mobile Computing, Networking and Communications, 2007. WiMOB 2007. Third IEEE International Conference on*. 72–72.
- [13] Q. Wang, W. Shin, X. Liu, Z. Zeng, C. Oh, B. K. AlShebli, et al. 2006. I-Living: An Open System Architecture for Assisted Living. In *Systems, Man and Cybernetics, 2006. SMC'06. IEEE International Conference on*. 4268–4275.
- [14] G. Wu, S. Talwar, K. Johnsson, N. Himayat, and K. D. Johnson. 2011. M2M: From Mobile To Embedded Internet. *Communications Magazine, IEEE*. 49: 36–43.
- [15] R. Kamal, M. S. Siddiqui, H. Rim, and C. S. Hong. 2011. A Policy Based Management Framework for Machine to Machine Networks and Services. In *Network Operations and Management Symposium (APNOMS), 2011 13th Asia-Pacific*. 1–4.
- [16] V. Tsiatsis, A. Gluhak, T. Bauge, F. Montagut, J. Bernat, M. Bauer, et al. 2010. The SENSEI Real World Internet Architecture. *Towards the Future Internet-Emerging Trends from European Research*. 247–256.
- [17] S. Fleck and W. Straßer. 2008. Smart Camera Based Monitoring System and Its Application to Assisted Living. *Proceedings of the IEEE*. 96: 1698–1714.
- [18] G. Lu, D. Seed, M. Starsinic, C. Wang, and P. Russell. 2012. Enabling Smart Grid with ETSI M2M standards. In *Wireless Communications and Networking Conference Workshops (WCNCW), 2012 IEEE*. 148–153.
- [19] T. Frantti, H. Hietalahti, and R. Savola. 2013. Requirements of Secure WSN-MCN Edge Router. In *Information Networking (ICOIN), 2013 International Conference on*. 210–215.
- [20] N. Baker. 2005. ZigBee and Bluetooth Strengths and Weaknesses for Industrial Applications. *Computing & Control Engineering Journal*. 16: 20–25.
- [21] J.-S. Lee, Y.-W. Su, and C.-C. Shen. 2007. A Comparative Study of Wireless Protocols: Bluetooth, UWB, ZigBee, and Wi-Fi. In *Industrial Electronics Society, 2007. IECON 2007. 33rd Annual Conference of the IEEE*. 46–51.
- [22] M. Sukor, S. Ariffin, N. Fisal, S. K. S. Yusof, and A. Abdallah. 2008. Performance Study of Wireless Body Area Network in Medical Environment. In *Modeling & Simulation, 2008. AICMS 08. Second Asia International Conference on*. 202–206.
- [23] N. Chowdhury and R. Boutaba. 2010. A Survey Of Network Virtualization. *Computer Networks*. 54: 862–876.
- [24] S. Kabadayi, A. Pridgen, and C. Julien. 2006. Virtual Sensors: Abstracting Data from Physical Sensors. In *Proceedings of the 2006 International Symposium on on World of Wireless, Mobile and Multimedia Networks*. 587–592.
- [25] M. M. Islam, M. M. Hassan, G.-W. Lee, and E.-N. Huh. 2012. A Survey on Virtualization of Wireless Sensor Networks. *Sensors*. 12: 2175–2207.