

FRONT-END DESIGN OF AN ULTRASONIC TOMOGRAPHY MEASUREMENT SYSTEM

HUDABIYAH ARSHAD AMARI^{1*}, RUZAIRI ABDUL RAHIM², MOHD HAFIZ FAZALUL RAHIMAN³, JAYSUMAN PUSPPANATHAN⁴

Abstract. This paper explains the front-end system design of an ultrasonic tomography. In this paper, the ultrasonic tomography techniques implements a non-invasive techniques which using 16 transceivers to investigate the multiphase flow of the pipelines. The flows include solid, gas and liquid phase in 100 mm pipelines. The advantages of using transceiver rather than separate transmitter receiver are discussed in this paper. The sensor arrangement, measurement techniques and hardware preparation are also discussed in this paper. The circuit design details, including the transmitter, receiver and peak detector are also presented and explained. This paper will be useful for the use of further ultrasonic tomography system development.

Keywords: Ultrasonic tomography; multiphase flow; non-invasive ultrasonic; transceivers; peak detector

Abstrak. Kertas kerja ini menerangkan tentang perancangan bahagian permulaan di dalam sistem tomografi ultrasonik. Dalam kertas kerja ini, teknik pelaksanaan tomografi ultrasonik secara luaran iaitu tidak mengganggu aliran dalaman paip diaplikasikan menggunakan 16 sensor gabungan pemancar dan penerima untuk mengesan fasa-fasa aliran di dalam paip. Fasa tersebut termasuk pepejal, gas dan cecair. Kebaikan menggunakan pengesan jenis gabungan berbanding pengesan berasingan dibincangkan di dalam kertas kerja ini. Cara penyusunan pengesan, teknik pengukuran dan penyediaan perkakasan juga dibincangkan. Butir-butir rekaan litar termasuk litar pemancar, penerima, dan litar pengesan puncak juga disertakan. Kertas kerja ini boleh membantu untuk pembinaan sistem tomografi ultrasonik yang lebih jauh

Kata kunci: Tomografi ultrasonik; aliran pelbagai fasa; ultrasonik

^{1,2&4} Faculty of Electrical Engineering, Universiti Teknologi Malaysia, 81310, UTM Johor Bahru, Johor Darul Ta'azim, Malaysia

³ School of Mechatronic Engineering, Universiti Malaysia Perlis, 02600 Arau, Perlis, Malaysia

* Corresponding author: hudabiyah_aa@yahoo.com

1.0 INTRODUCTION

Process tomography refers to a method of acquiring the internal characteristics of pipelines flows or process vessel reaction from the measurements on the domain of interest. Current industries are increasingly interested in this field as tomography brings much applications as well as advantages to the system. Over two decades of research worldwide, process tomography has become a routine research tool in many research laboratories and is being accepted for process measurement and control in some industrial applications. In chemical process, tomography will be useful to estimate the spatial distribution of phases and chemicals inside their processing vessels or pipelines, giving instant feedback on reaction processes, or efficiency of transport. The 3D images can be reconstructed from non-invasive peripheral sensing which make it easier to monitor the internal reaction of online process. In pharmaceuticals and fine chemicals, monitoring the critical processes of high value products is essential, and in the food industry, tomography offers great insights into the structural transformations found in colloids and gels. In mineral engineering, tomography can monitor separation and transport operations continuously, helping ensure maximum production. While in the oil and gas industries, process tomography can deliver valuable information for a variety of processes such as, characterisation of multiphase flows, separation of multiphase components and homogeneity of packed beds and process vessels [1]. In addition, process tomography can be valuable tool in testing and validation of process models such as computational fluid dynamics (CFD).

2.0 ULTRASONIC TOMOGRAPHY

Various techniques exist in process tomography, so the best and suitable technique should be choose depends on the components inside the vessels in this case solid, liquid and gas. Ultrasonic process tomography is useful for imaging processes where differences in object density and elasticity offer the most significant sensing opportunity [2]. In general the object will interact with an ultrasound beam through some form of acoustic scattering. The interaction may then be sensed to yield information about the object or field [3].

There are three types of sensing techniques which is transmission mode, reflection sensing mode and diffraction mode [4]. In this paper, the transmission-mode technique was utilized. The transmission mode technique is based on the measurement of the changed in the properties of the transmitted acoustic wave. Then, it gives advantages over the other techniques since there are three different intensity of material in the measuring pipe which gives different acoustic impedance of each material. The systems consists of ultrasonic pulse generators to

excite the transducers to transmit and receive the waves. The information gathered then will be processed to develop the reconstructed images of components inside the process vessels.

In the study of tomography, the physical principle of a sensing system depends on the reconstructed image of the cross-sectional distribution of the parameter. It is evaluated by arraying ultrasonic sensors non-invasively on the surface of the vessel. By using the electronic circuits to interface, the data captured can be processed and analyzed by the computer to reveal the information of the internal dynamic characteristics [5, 7].

3.0 HARDWARE DEVELOPMENTS

One of the most important parts in an ultrasonic tomography system is the front end that is the transducer array and associated electronic hardware. This is important for acquiring the data needed to produce a meaningful image. This is fundamental to the success or failure of an acoustic imaging system. Therefore, given the object to be imaged and the specifications to be achieved, the design of the front end of an acoustic imaging system should be regarded as a first priority [8].

3.1 Transceiver

Ultrasonic transceiver is a type of transducer that converts electrical energy into high frequency sound waves and also converting sound waves back to electrical energy. It contains piezoelectric crystal materials that have the ability to transform mechanical energy into electrical energy and vice versa [7]. Piezoelectric crystals have the property of changing size when a voltage is applied, thus applying an alternating current (AC) across them causes them to oscillate at very high frequencies, thus producing very high frequency sound waves.

For using piezoelectric transceiver, certain characteristics need to be evaluated to determine the properties of the transceiver that are suitable for specific application. For instance, the size, frequency, sensitivity, beam angle, driving voltage and others. Selection for the right transceivers is the first priority since it is in the front-end of the ultrasonic tomography system together with associated hardware. Other factors that contribute to the selection of the sensor are the sound pressure level (SPL) and the centre frequency shift against temperature variations [9].

3.2 Sensor Arrangement

A sensor jig as in Figure 1 was designed to put the sensor into order well around the pipe vessel. It was fabricated to fit 16 transceiver of size 14.1 mm. The jig is created with accurate position, angle and thickness for each sensor. The use of sensor jig will reduce the error of the projected signal due to the echo effect [10].



Figure 1 Sensor jig

All 16 transceivers are enclosed in the jig that designed for 100 mm pipe diameter. This situation shows the advantage of using transceiver rather than using separate transmitter receiver sensor. Since the number of sensors may improve the quality of reconstructed image, transceivers are the best choice. Transceivers have dual functionality which can be switch either as transmitter or receiver. Thus, it will give about half extra space to locate the transceiver around the pipe. For example, by using common ultrasonic sensors functioning separately, only 8 transmitters and 8 receivers can be applied instead of using dual functionality transceiver, 16 sensors be able to installed.

When a transceiver is set to be transmitter, the other transceiver will be functioning as receivers. It will be connect to transmitter circuit when function to transmit and connect to receiver circuit when function to receive. The timing circuit is very important since incorrect switching timing leads to inaccurate measurement data [11].

The cross section of the sensor arrangement shown in Figure 2 which is also an example of fan shaped beam sensor array. The transceivers enable the transmission and reception on the same sensor.

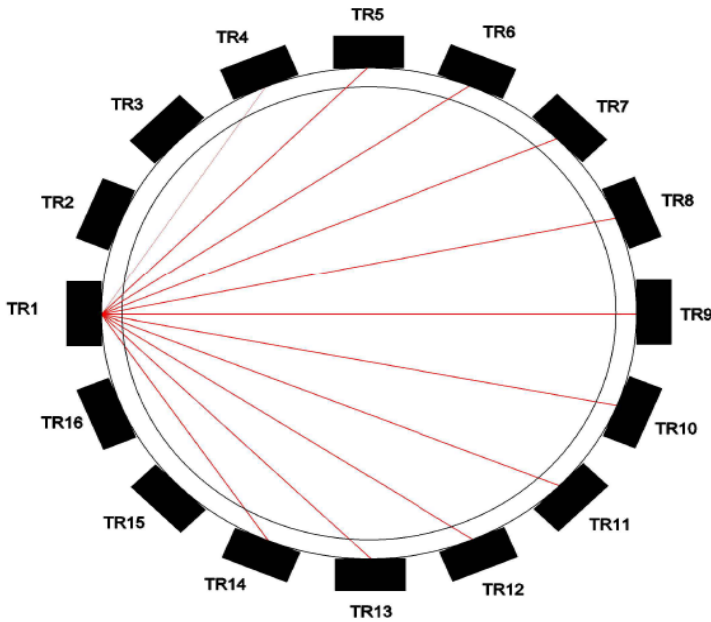

Figure 2 Ultrasonic transceivers sensor arrangement

The transceiver chosen has 125° beam angle and from Figure 2, it clearly shown that only 11 transceiver are within the region. The other 5 are outside the boundary including the excite one. So, there are 11 measurement in one projection, hence totally 176 measurement will be obtained. Compared to separate transmitter receiver with same beam angle on a same diameter of pipe and same sensor size only, 6 sensors within the boundary with total of 48 measurements will be taken. Therefore results in image generated that much more blurred.

3.3 Electronic Circuit

In tomography system, the front-end is important as it need to obtain data with high accuracy since the measurement data are used for image reconstruction part. The Figure 3 shows the block diagram of ultrasonic tomography system. The microcontroller unit (PIC18F4520) is used as signal generator to generate a 40kHz signals to transmitters while the receiver will received the projected signals [8, 12]. The readings from receiving transceivers are sent to the signal conditioning circuit. The output of this circuit will go through peak detector circuit which then are sent to personal computer via USB connection from the DAQ system for image

reconstruction. In this research, the Data Acquisition System, NI USB 6218 from National Instruments is used to acquire and transfer the data via Labview software.

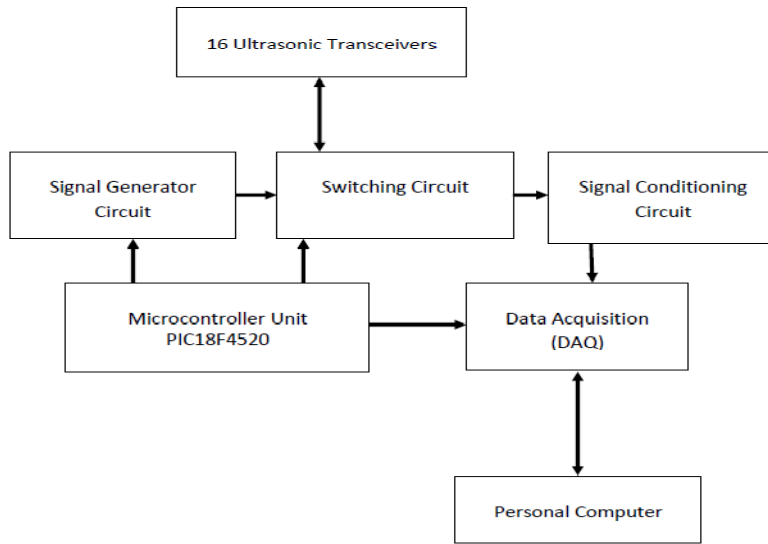

Figure 3 Block diagram of ultrasonic tomography system

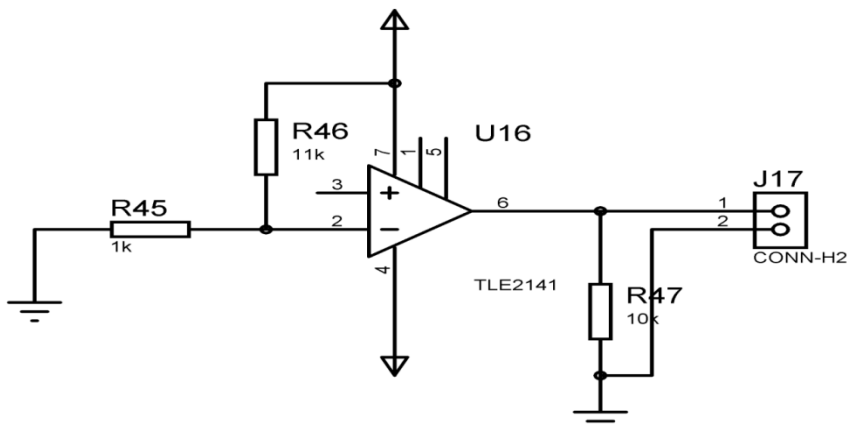

Figure 4 Signal generator circuit

The signal generator circuit was designed using low noise high-performance; internally compensated operational amplifiers built using Texas Instruments complementary bipolar Excalibur process, which act as comparator as shown in Figure 4. The comparator will generate 30 V_{p-p} tone burst of 40 kHz with

reverberation delay of 100 Hz. The duration for every pulse generation is chosen because within this delay time, the reverberation effects will stop before new excitation is activated.

The signal conditioning circuit consists of two components which is signal receiving circuit and peak detector circuit as shown in Figure 5 and Figure 6. The receiving circuit which also is an amplifier circuit using the audio operational amplifier, LM833. This op-amp is a high speed op-amp with excellent phase margin and stability. The amplifier was design in two stages with inverting amplifier connection. The first stage is the pre-amplifier with gain $AA = -120$ and the second stage is to amplify with gain $AB = -120$. The received signals are amplified through these two stages to amplify twice.

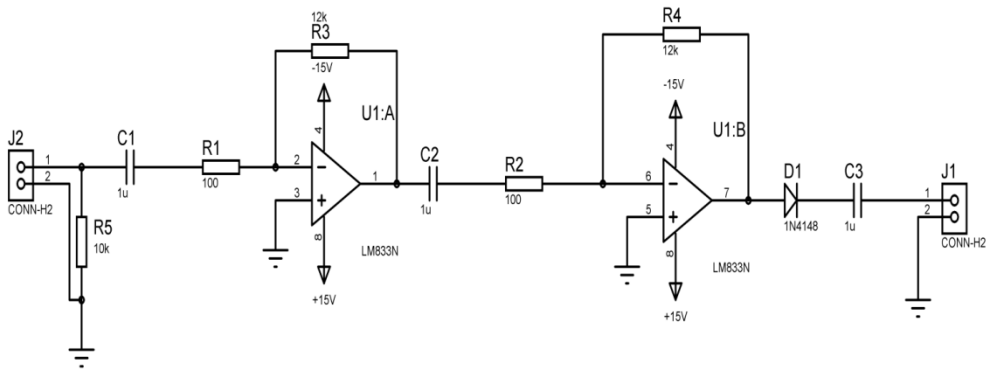

Figure 5 Signal receiving circuit

A peak detector is a series connection of a diode and a capacitor outputting a DC voltage equal to the peak value of the applied AC signal. The circuit is shown in Figure 6, an AC voltage source applied to the peak detector, charges the capacitor to the peak of the input. The diode conducts positive half cycles charging the capacitor to the waveform peak. When the input waveform falls below the DC peak stored on the capacitor, the diode is reverse biased, blocking current flow from capacitor back to the source.

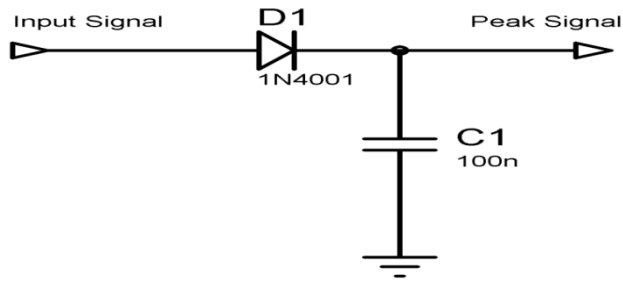

Figure 6 Peak detector circuit

4.0 RESULTS AND DISCUSSIONS

The signals shown in Figure 7 are transmitting pulse tone and receiving signal by the ultrasonic transceiver captured using oscilloscope. Amplifying the received ultrasonic signals is vital because the original receive signal might be too small and hard to process in the next level. However, the amplified gain must not be too large as the output signal will saturated in which the signals might be clipped out at positive and negative peak. This will bring an error to the final results. As be seen in the receive wave, there is a slight distortion occur. This is because, the wave are going through several layer before reaching the receiver. It has to penetrate the pipe wall then go through the water or components inside and break in the wall again before reaching the receiver.

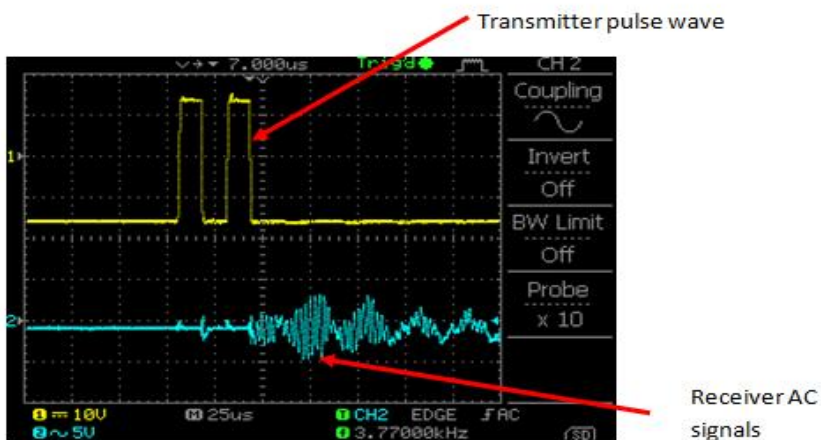

Figure 7 Ultrasonic pulse tones and receiver signals

Peak detector output is shown in Figure 8. It changes AC ultrasonic wave from the receiver signals above into a DC voltage. The peak detector will capture the most high peak signal to be changed to DC signal. Then, the highest voltage as shown in Figure 8 will be taken for further imaging reconstruction. The implementation of this peak detector circuit will give faster response time as well as simpler integration into the system and also for more compact board design [13].

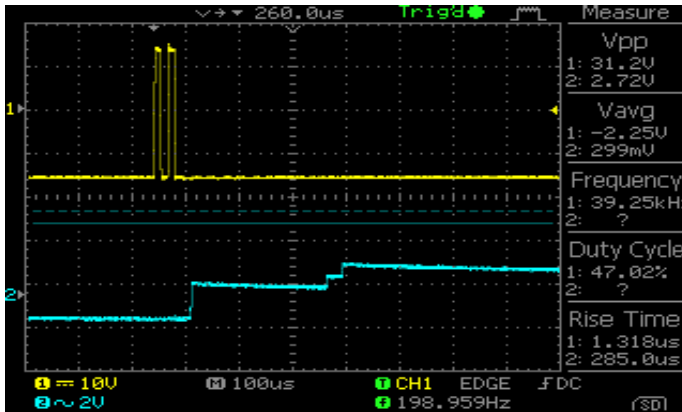

Figure 8 Peak detector output

5.0 CONCLUSIONS

In designing the ultrasonic tomography system, the selection of suitable transducer needs to give more consideration and attention. The use of transceiver give much advantages in terms of space number of projections that will results in better image reconstruction. Besides that, the clamping technique are also important as well as the signal processing systems.

ACKNOWLEDGMENTS

We greatly appreciate Universiti Teknologi Malaysia and PROTOM research group for providing the facilities which enable this project to be done. We are also grateful for the consultation and cooperation of I-Stone Sdn. Bhd during the process of this study.

REFERENCES

- [1] H. McCann, B. S. Hoyle. Virtual Centre for Industrial and Process Tomography. [Online] Available from http://www.vcipt.org/what_is_tomography.html.
- [2] R. A. Williams, M. S. Beck. 1995. *Process Tomography: Principles, Techniques and Applications*. Butterworth-Heinemann Ltd.
- [3] W. Li, B. S. Hoyle. 1997. Ultrasonic Process Tomography using Multiple Active sensors for Maximum Real-Time Performance. *Chemical Engineering Science*. 52: 2161-2170.
- [4] N. Reinecke, G. Petrisch, D. Schmitz, D. Mewes. 1998. Tomographic Measurement Techniques: Visualization of Multiphase Flows. *Chemical Engineering Technology*. 21: 7-18.
- [5] B.S. Hoyle. 1996. Process Tomography using Ultrasonic sensors. *Measurement Science Technology*. 7: 272-280.
- [6] L. J. Xu, L. A. Xu. 1997. Gas/Liquid Two-Phase Flow Regime Identification by Ultrasonic Tomography. *Flow Measurement Instrument*. 8: 145-155.
- [7] M. H. Fazalul Rahiman, R. Abdul Rahim. 2010. Development of Ultrasonic Transmission-mode Tomography for Water-Particles Flow. *Sensors & Transducers Journal*. 6: 99-105.
- [8] Z. Zakaria, M.H. Fazalul Rahiman, R. Abdul Rahim, A.F. Salleh, A.H. Jahidin. 2009. *Ultrasonic Tomography: The Applications of 32 Transceivers Technique in Two Phase Flow Imaging*. Universiti Malaysia Perlis.
- [9] S. Ibrahim, S. N. Syed Salim. 2007. *Ultrasonic Process Tomography*. Universiti Teknologi Malaysia.
- [10] M. H. Fazalul Rahiman, R. Abdul Rahim, S. Yaacob, Z, Zakaria, M. R. Manan. 2009. *A Comparative Study on Ultrasonic Transceiver Sensing Array for Bubbly Gas Hold Ups*. Universiti Malaysia Perlis.
- [11] R. Abdul Rahim, M. H. Fazalul Rahiman, W. N. Ng, K. S. Chan. 2004. *Initial Results on Monitoring Liquid/Gas Flow using Ultrasonic Tomography*. Universiti Teknologi Malaysia.
- [12] M. H. Fazalul Rahiman, R. Abdul Rahim, M. H. Fazalul Rahiman, M, Tajuddin. 2006. Ultrasonic Transmission-Mode Tomography Imaging for Liquis/Gas Two-Phase Flow. *IEEE Sensors Journal*. 6: 1706-1715.
- [13] N. M. Nor Ayob, M. H. Fazalul Rahiman, S. Yaacob, R. Abdul Rahim. 2009. *Ultrasound Processing Circuitry for Ultrasonic Tomography*. Universiti Malaysia Perlis.