

FRONT END DEVELOPMENT OF OPTICAL TOMOGRAPHY AND ITS LINEARITY

SITI ZARINA MOHD MUJI^{1*}, YUSRI MD YUNOS², RUZAIRI ABDUL
RAHIM³ & MOHD HAFIZ FAZALUL RAHIMAN⁴

Abstract. Front end development is crucial in optical tomography. It gives the first impression on how reliable the tomography system towards its measurement. Therefore, transmitter and receiver circuit must be developed carefully with good analysis for each selection of the component units. This paper will show the effect of circuit development towards linearity performance. The aim of this paper is to construct a transmitter and receiver circuit for optical tomography application. This is done by capturing a voltage unit at the receiver side in response to the existence of obstacle that interrupt the light path between transmitter and receiver. The experiment design uses a same type of obstacle with different sizes between 0.5 until 3mm. From the result it shows the bigger the object the voltage loss value also increasing. This shows a linear relation between both parameters.

Keywords: Optical tomography; transmitter; receiver; circuit; linearity

Abstrak. Pembangunan bahagian hadapan adalah penting di dalam tomografi optikal. Ia memberikan pandangan pertama tentang bagaimana kebolehpercayaan sistem tomografi kepada pengukurannya. Oleh itu, litar penghantar dan penerima mesti dibina berhati-hati dengan analisis yang baik untuk setiap pemilihan unit komponennya. Kertas kerja ini akan menunjukkan kesan pembangunan litar kepada mutu kelinearannya. Tujuan kertas kerja ini adalah untuk membina litar penghantar dan penerima untuk aplikasi tomografi optikal. Ia dilakukan dengan mendapatkan unit voltan pada bahagian penerima setelah bertindak balas terhadap kewujudan penghalang yang mengganggu laluan cahaya di antara penghantar dan penerima. Reka bentuk eksperimen ini menggunakan penghalang dari jenis yang sama dengan perbezaan saiz di antara 0.5 hingga 3 mm. Daripada keputusan ia menunjukkan lebih besar objek, nilai bagi kehilangan

¹ Faculty of Electrical and Electronic Engineering, Universiti Tun Hussein Onn Malaysia, 86400 Parit Raja, BatuPahat, Johor

^{2,3} Department of Control and Instrumentation, Faculty of Electrical Engineering, Universiti Teknologi Malaysia, 81310 Skudai, Johor

⁴ Tomography Imaging Research Group, School of Mecatronics Engineering, Universiti Malaysia Perlis, Ulu Pauh Campus, 02600 Arau, Perlis, Malaysia

* Corresponding author: szarina@uthm.edu.my

voltan juga akan meningkat. Ini menunjukkan hubungan yang linear di antara kedua-dua parameter.

Kata kunci: Tomografi optikal penghantar; penerima; litar; kelinearan

1.0 INTRODUCTION

The response of the circuit on the linearity towards the obstacle diameter is very important. For optical tomography, to examine the process parameters or flow field, the linear interaction is important [1]. It gives a first impression on how well the system because the better the linearity of the system definitely affects to the measurement of concentration profile and mass flow rate.

The principle behind light is it travels through the vacuum and it is measured in c (*Celeritas*) which is 299,792,458 meters per second [2]. Light has a criterion of absorption, diffraction, and reflection/ refraction [1]. The absorption of light during wave propagation is often called attenuation. This criterion is the main interest in this research as the objective is to get the concentration profile and mass flow rate of the solid gas material in gravity chute conveyer. The diffraction is usually used for particle sizing and this is not the scope in this research. In this research, a modeling of reflection and refraction will not be focused as these two parameters settle when used tomography [1]. This is due to a combination of many projection in tomography that still can produce an image although there has many nonlinear effect such as reflection, refraction or scattering.

Therefore the construction of this circuit will involve the attenuation factor only. The previous studies were using different kind of sensor in the transmitter side and also different kind of photo detector at the receiver side. Research by Chan in 2002, was used LED as a source and PIN photodiode as a receiver [3]. LED is a type of visible light and its operation is easy to be monitored as the light can be seen by a human eyes. The drawback of LED; this light cannot be distinguished with the noise and it interrupted the signal response. Therefore in this study an infrared LED will be used as it characteristic of invisible to human eyes and the noise definitely has a different wavelength with visible light. In this research an infrared will be used and it can differentiate noise effectively as the wavelength of noise (ordinary light), is differ from infrared.

For the receiver side, there are two kind of photo detector that always been using by researcher which is photodiode and phototransistor. A photodiode will

be used rather than phototransistors as it have a fast response. In this research the receiver that was used has a filter inside that able to capture a true signal and filter the noise.

2.0 METHODOLOGY

2.1 The Construction of Transmitter Circuit

Microcontroller will damage if the current that are flowing through it is over 25 mA [4]. By using transistor in the circuit, microcontroller will 'on' the base. The transmitter circuit will be activated by collector. Therefore if the current is over, it will not damage the microcontroller, where it only affects the transistor. When the switch is closed a small current will flow into the Base (B). R₁ control the current flow in the base. This small current will be amplified by transistor to allow larger current to flow from Collector (C) to Emitter (E). ZTX689B is selected since this transistor has the equivalent characteristic of Darlington transistor and capable of supply the collector with constant current up to 3 Amp or pulse current up to 8 Amp and switching frequency up to 1 MHz. Collector current is large enough to make infrared emitter to "ON". The pin from microcontroller will control the pulsing process of light emitting circuit. Figure 1 shows the transmitter circuit for this system.

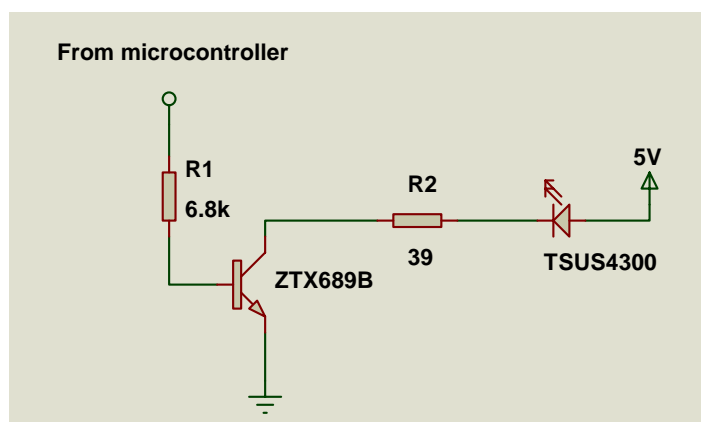

Figure 1 Transmitter circuit

Given the forward voltage for TSUS 4300 is 2.2 V and the forward current for TSUS 4300 is 100 mA. Minimum value of R₂ can be found by using Equation 1 where the value is 28 Ω.

$$R_2 = \frac{V_{cc} - V_f}{I_f} \quad (1)$$

In this research, 39 Ω were selected and will produce 71 mA of current. This current is not exceeding 100 mA and it is allowable in this circuit. R₂ secures TSUS4300 from exceed the limit current when I_c suppresses maximum forward current permitted by TSUS4300.

2.2 The Construction of Receiver Circuit

The receiving circuit is the last part in the front end system that will send the data to the data acquisition system. Figure 2 shows the receiving circuit in this project where the photodiode will be used and the arrangement of photodiode is using photovoltaic mode. Due to the increasing in dark and noise current when using the photoconductive mode, this arrangement is avoided [5]. The photodiode is unbiased and have a zero voltage across the photodiode. This mode is preferred for precise linear measurement of low light levels applications due to low noise level [5]. The zero bias operation in photovoltaic mode introduce a higher sensitivity mode of operation and most photodiode work effective in this mode [6]. There are four essential elements in this circuit particularly (1) current to voltage converter, (2) amplifying (3) filtering (4) voltage divider.

Photodiode is producing current; therefore to amplify the signal from photodiode the current should be converted to useful voltage. This can be done using operational amplifier and the circuit is called transimpedance amplifier. Operational amplifier is almost always required as an addition to the photodiode unit to make it useful for infrared detector [7]. Therefore in this stage, there are both functions which are to convert current to voltage and to amplify it. I_m from the photodiode will be multiplied to resistor R_f. To make sure the voltage is enough for the purpose of one stage amplifier therefore the large resistor is being used. A very high resistance feedback resistor is much better than a low resistance [6]

where the low feedback resistance will generate higher current noise. Equation 2 shows the relation of current to voltage converter.

$$V_{out} = I_{in} \times R_1 \quad (2)$$

For Figure 2, the transimpedance gain, A , is given by Equation 3, where the DC amplification is only due to the feedback resistor value [5].

$$A = V_{out} / I_{in} \quad (3)$$

The same value of resistor, R_2 is needed to add at the non-inverting amplifier to make sure there is no offset in the circuit [8]. For op-amp type, TLE2141 is being chosen because of many reasons; good dc performance, low noise, low signal distortion and slew rate (SR). SR is to determine the speed of an op amp [9]. The slew rate must be greater than the slew rate of the circuit. Here, the slew rate of TLE2141 is 45 V/ μ s which is greater than the slew rate for this circuit that is calculated using SR formula,

$$SR = \pi V_{pp} f_c \quad (4)$$

The slew rate for receiver circuit is $0.6 \frac{V}{\mu s}$, which is lower than the slew rate of TLE2141. Hence, TLE2141 is suitable to be used in this circuit. TLE2141 is a type of single supply op amp. The signal sources are reference to ground. Therefore, single supply exhibits a large input common-mode voltage [10].

The third part in this circuit which is filtering, and it is utilizing one feedback capacitor. The purpose of adding this capacitor is to stabilize the op amp. The input capacitance of an op-amp can cause instability when op amp is used with feedback resistor. Therefore, the feedback capacitance will make it stable [11]. The instability will cause a noise, therefore it is considered as filtering when this connection is established. Equation 5 shows how to stabilize the op-amp.

$$C_f \times R_f = C_{in} \times R_{in} \quad (5)$$

This capacitor also functions to suppress oscillation or gain peaking [6]. It only needs a small value to ensure loop stability. To ensure the design has a large

bandwidth and stable, the value for feedback capacitor must be calculated carefully. Using Equation 6, the combination between feedback resistor and feedback capacitor produce a frequency needed to be filtered in this design.

$$\begin{aligned} f &= \frac{1}{2\pi R_f C_f} \\ &= \frac{1}{2\pi 3.3M .3p} \\ &= 16 \text{ kHz} \end{aligned} \quad (6)$$

From Equation 5, the value for the frequency filtered is approximately 16 kHz.

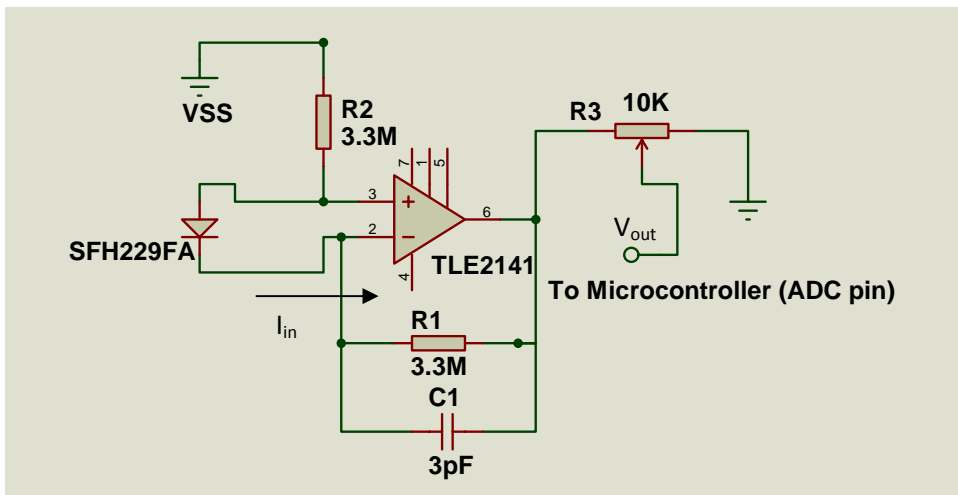

Figure 2 Receiver circuit

The last part in receiver circuit is voltage divider. Voltage divider circuit includes a variable resistor to adjust and make a calibration in the measurement experiment. Photo detector circuit is a very high impedance and very high sensitivity circuit, therefore it needs a good shielding and effective power supply bypassing and it is not optional [6].

Figure 3 shows the signal in the receiver upon receiving the light pulse from transmitter. It shows a steady state after 34 μ s, therefore data can be sampled after this time.

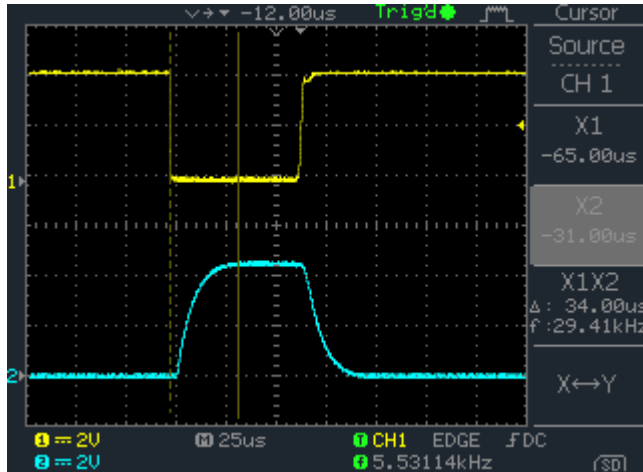

Figure 3 Receiver shows steady state mode after 34 μ s get the pulse from transmitter

3.0 RESULT AND ANALYSIS

Linearity is important to make sure the circuit response follow the exact performance. An experiment was conducted to see this effect towards receiver response. Obstacles with different diameter from 0.5 until 3mm were used to see whether the receiver voltages will response linearly with the change of obstacle diameter. Figure 4 shows the graph between real experiment result and ideal result. The ideal result will give R^2 equal to one, while for the experiment it gives 0.9382. The different of R^2 between the real hardware and numerical method is 0.062%. This error is small and it shows the real experiment proved the approximation with the theory.

4.0 CONCLUSION

Linearity response is important for circuit performance as it will result in exact interaction between voltage loss and obstacle diameter in tomography system. Therefore, a right choice of sensor and its component unit while building the circuit is important to make sure its follow the linearity law.

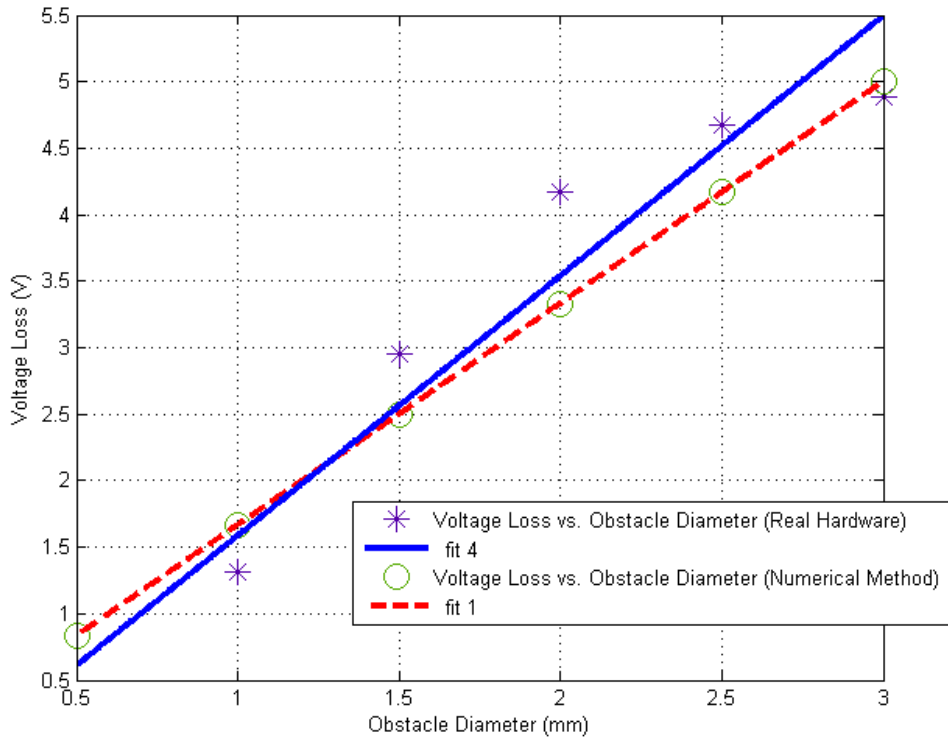

Figure 4 Comparison between ideal and experimental result of linearity on obstacle effect towards voltage measurement

REFERENCES

- [1] R. G. Jackson. 1995. The Development of Optical Systems for Process Imaging in *Process Tomography: Principles, Techniques and Applications*. Butterworth Heinemann.
- [2] *Celeritas*. Cited on 3 February 2011 Available: <http://en.wikipedia.org/wiki/Celeritas>.
- [3] R. Abdul Rahim and K. S. Chan. 2004. Optical Tomography System for Process Measurement using LED as a Light Source. *Optical Engineering*, 43: 1251-1257.
- [4] Microchip. 2004. PIC18F2420/2520/4420/4520 Data Sheet. Available: <http://www.microchip.com/>.
- [5] D. Birtalan. 2009. Interfacing to the Photosensor in *Infrared Visible Ultraviolet Devices and Applications*. 2nd ed. CRC Press.
- [6] B. B. Corporation. 1994. Designing Photodiode Amplifier Circuit with OPA128. Available: <http://focus.ti.com/lit/an/sboa061/sboa061.pdf>.
- [7] D. Birtalan. 2009. The Photodiode in *Infrared Visible Ultraviolet Devices and Applications*. 2nd ed. CRC Press.
- [8] G. G. Jerald. 1996. *Photodiode Amplifier Op Amp Solutions*. New York: McGraw-Hill.

- [9] T. Kugelstadt. 2003. *Active Filter Design Techniques*.
- [10] R. Mancini. 1999. Single-supply Op Amp Design.
- [11] B. Pease. 2001. *What's All This Transimpedance Amplifier Stuff, Anyhow? (Part 1)*. Available: <http://electronicdesign.com/article/analog-and-mixed-signal/what-s-all-this-transimpedance-amplifier-stuff-any.aspx>.