

Indoor and Built Environment

<http://ibe.sagepub.com/>

Investigating Daylight Quality Using Self-Shading Strategy in Energy Commission Building in Malaysia

Mansour Nikpour, Mohd Zin Kandar and Elahe Mosavi

Indoor and Built Environment 2013 22: 822 originally published online 12 September 2012

DOI: 10.1177/1420326X12458512

The online version of this article can be found at:

<http://ibe.sagepub.com/content/22/5/822>

Published by:



<http://www.sagepublications.com>

On behalf of:



[International Society of the Built Environment](http://www.sagepub.com/content/22/5/822)

Additional services and information for *Indoor and Built Environment* can be found at:

Email Alerts: <http://ibe.sagepub.com/cgi/alerts>

Subscriptions: <http://ibe.sagepub.com/subscriptions>

Reprints: <http://www.sagepub.com/journalsReprints.nav>

Permissions: <http://www.sagepub.com/journalsPermissions.nav>

Citations: <http://ibe.sagepub.com/content/22/5/822.refs.html>

>> [Version of Record](#) - Oct 1, 2013

[OnlineFirst Version of Record](#) - Sep 12, 2012

[What is This?](#)

Investigating Daylight Quality Using Self-Shading Strategy in Energy Commission Building in Malaysia

Mansour Nikpour^{a,b} Mohd Zin Kandar^a Elahe Mosavi^{b,c}

^aArchitecture Department, Faculty of Built Environment, Universiti Teknologi Malaysia, Johor, Malaysia

^bIslamic Azad University, Bam Branch, Iran

^cYoung Researchers Club, Bam Branch, Iran

Key Words

Self-shading strategy · Office building · Daylight quality · Work plane illuminance · Relative daylight ratio

Abstract

There are a lot of office buildings without strategies for daylight utilization. Different strategies are suggested for better use of daylight. Self-shading strategy has been suggested to eliminate direct solar radiation to minimise energy use for cooling in offices but, the amount of daylight penetrating into the building can be reduced. In this research, the effectiveness of self-shading strategy on daylight is investigated through experimental method. Daylight parameters are measured in two individual office rooms in Energy Commission Building as a model of self-shading buildings. The objective is to investigate daylight quality in individual office room based on different criteria such as work plane illuminance, relative daylight ratio, surface luminance have been compared with recommended values.

Finding of this research demonstrates that by employing self-shading strategy, the amount of daylight that enters the space could reduce but by applying other strategies like light shelves and venetian blinds, with self-shading strategy, acceptable performance in terms of daylight quality can be achieved. These strategies can be employed for future design of office buildings to reduce energy consumption for lighting as well as to comply with the goal of sustainable architecture.

Introduction

Malaysia has a hot and humid climate. Buildings, especially high-rise building, would receive excessive solar radiation that could cause high solar heat gain [1].

Architects should have a particular consideration of the environment, especially energy use in buildings in design process [2,3]. More than 50% of the electricity energy is

consumed in commercial buildings. Two main sources of energy consumption are air-conditioning and artificial lighting in office buildings [4]. Air-conditioning can consume 50–60% of total electricity, while 20–30% of total electricity use is for lighting [5]. Daylighting would not only reduce electricity demand for artificial lighting but also provide more luminous compared to artificial lighting, and less heat is generated [2].

Designers are encouraged to develop lighting strategies to reduce energy consumption for artificial lighting and cooling demand of Heating, Ventilation, Air Conditioning (HVAC) system to reduce environmental effects [6]. Solar radiation is the most important factor among other factors in overall thermal transfer value (OTTV) equation. Solar radiation is affected by window-to-wall ratio (WWR) and solar coefficient [7]. More solar heat would mean more energy use for heating, ventilation, air conditioning cooling requiring larger air-conditioning system [8].

On the other hand, solar heat gain could also cause more daylight. Integrating daylight and electric light could reduce energy consumption. Large window area would increase energy consumption due to cooling demand, but some energy use would be saved due to reduced lighting requirement [9]. Daylighting has become an interesting issue for energy conservation [10].

Energy consumption in buildings could be controlled by two approaches which are OTTV and daylighting. Annual incremental electricity use is correlated with OTTV and daylight aperture [9]. Airy architecture of beauty can be created by proper use of daylighting to engender comfort and a feeling of wellbeing for occupants as well as to reduce the sensible cooling load and should be an important aspect of an energy efficiency strategy for building designers [11].

Lam and Li [12] identified the balance between daylighting and solar heat gain. Daylighting, solar heat gain and evaluation methodology were analyzed with respect to window design.

Zain-Ahmed et al. [6] revealed that with increasing WWR, the solar heat gain would increase as well. If the size of window is increased by more than 25%, the amount of heat gain would increase while more light would not be needed. It can be inferred that the optimum size for WWR is 25% in Malaysia [6]. This study was further supported by Al-Tamimi and Fadzil's evaluation of thermal performance of ventilated and unventilated glazed rooms in Malaysia [13].

Previous study demonstrated that appropriate lighting could be available in the office buildings in more than 50% of the working hours of a year solely by using daylight.

Building area, building orientation, type of glazing, shading devices and colour of external surfaces are effective parameters for daylight design [14].

Designer can select the best form of building by identifying suitable daylight level for a desirable situation in a building [15]. WWR has an important role which can affect the amount of daylight penetrating into the building [14]. Solar energy and effect of solar energy on the thermal performance could be controlled by building form and sun location [16–19]. Knowles [20] demonstrated the effect of size and shape of envelopes of three different blocks on energy consumption. Also, the shape factor of form and the most appropriate orientation of a building, which can increase energy performance, were identified [21].

Adamski [22] have found the optimum form of building by taking into account both minimum construction cost and minimum seasonal demand for heat energy. Ratti et al. [23] surveyed shadow density and heat gain on three basic forms of blocks. Researchers suggested that courtyard form could make the best use of land in hot-dry climate, but in hot humid climate, the courtyard form might not be appropriate [23]. Kumar et al. [24] identified the effect of characteristics design factor on green house microclimate in tropical regions. Design and its component such as shape, height, orientation, covering materials, shading, ventilation and green house cooling technology were discussed [24].

Chia et al. [25] revealed that vertical wall in high rise buildings could receive 86.6% of the annual solar isolation. The researchers demonstrated that circular form with W/L 1:1 would be the optimum shape because this form would receive the lowest annual solar isolation among high rise buildings [25]. Okeil [26] identified a special urban block form which can be highly energy efficient and showed how forms can be optimized to enhance energy performance [26].

Building forms are related to building envelope U-Values and these are important factors that could influence heat flux through the whole building [27]. Building volume could also have an important effect on energy efficiency. Building with larger floor space would be more energy efficient. A building of larger volume or taller and narrower in shape would tend to be more efficient [28].

According to Capeluto [29], self shading geometry forms could provide the best solution for a better use of energy in buildings. Energy consumption in building can be controlled with two parameters, which are OTTV and daylighting [30]. Chirarattananon [31] assessed lighting and cooling-energy performance of a building envelope, by employing appropriate envelope parameters such as the WWR, optimum performance can be achieved.



Fig. 1. A type of self-shaded building-free view section [29].

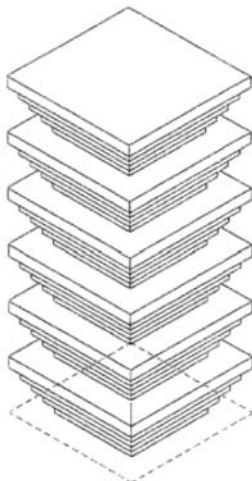

Fig. 2. Self-shaded high rise building [1].

Energy consumption could be reduced by using appropriate daylight design [9]. More light transmittance would mean more daylight and hence less electricity consumption for electric lighting and less heat gain from electric lighting [32]. Li and Lam [33] demonstrated that larger window area would mean more daylight transmittance and cause a reduction in heat gain from artificial lighting.

Self-protected form is one of the possible ways against the impact of solar radiation in high rise buildings. Self-shading building envelopes have been suggested for solar prevention (Figure 1) [29].

Chia [1] identified optimum self-shading projection ratio for high rise building in Malaysia. Researcher identified the optimum form for office building in Malaysia through reducing solar isolation on envelopes with self-shades form (Figure 2) [1]. A large amount of energy is consumed for providing the sufficient daylight and thermal comfort especially in high rise buildings [34].

Ibrahim and Zain-Ahmed [35] predicted the impact of envelope design options on the potential of energy savings through daylighting.

Ossen et al. [36] investigated the effectiveness of geometrical characteristics of external shading devices on energy consumption for both cooling and lighting. Using external shading devices could cause higher energy consumption for lighting. In addition, more energy is consumed resulting from electric lighting heat waste. Researcher suggested optimum characteristics of overhang for each direction [36].

Lim et al. [37] demonstrated the optimum use of energy for office building with a consideration of different factors such as geometry of shading devices, room and WWR. The level of heat gain and daylight could be traded-off. Researchers demonstrated that by increasing the amount of WWR or Overhang Ratio (OHR), the influence of external shading devices could be enhanced. The optimum overhang ratio would depend on WWR and Room Depth Ratio (RDR) [37]. The ideal window area was presented by Ghisi and Tinker [38], which includes a consideration to integrate daylighting and artificial lighting [38]. Tzempelikos and Athienitis [39] investigated the effectiveness of window area, shading devices on energy consumption for both lighting and cooling. Lim and Ahmad [40] demonstrated that most office buildings could not achieve mean work plane illuminance (WPI) more than 300 lux. They specified ceiling height, surface reflectance and shading devices to be important factors in their design of daylighting. Furthermore, internal shading devices could have an important role in the control of daylighting [40].

There are several standards used for electric lighting. In Malaysia, the Malaysian Standard 1525:2007 has outlined

Table 1. Recommended average illuminance levels [41]

Task	Illuminance (lux)	Example of applications	
Lighting for infrequently used area	20	Minimum service illuminance	
	100	Interior walkway and car park	
	100	Hotel bedroom	
	100	Lift interior	
	100	Corridor, passageways, stairs	
	150	Escalator, traveller	
	100	Entrance and exit	
	100	Staff changing room, locker and cleaner room, cloak room, lavatories, stores.	
	100	Entrance hall, lobbies, waiting room	
	300	Inquiry desk	
	200	Gate house	
	Lighting for working interiors	200	Infrequent reading and writing
		300–400	General offices, shops and stores, reading and writing
300–400		Drawing office	
150		Restroom	
200		Restaurant, canteen, cafeteria	
150–300		Kitchen	
150		Lounge	
150		Bathroom	
100		Toilet	
100		Bedroom	
300–500		Class room, library	
Localized lighting for exacting task	200–750	Shop/supermarket/department store	
	300	Museum and gallery	
	500	Proof reading	
	1,000	Exacting drawing	
	2,000	Detailed and precise work	

the illuminance levels recommendations for various tasks and applications as shown in Table 1. The recommended daylight factor (DF) for an effective daylight-lit office space is 1.5%. This standard should be employed as benchmark in lighting study in Malaysia [41].

Dubois [42] studied various lighting quality standards from different sources such as IES and CIE. A combination of these standards was used for daylight as shown in Table 2.

Daylight parameters in 41 different rooms in 5 buildings in different places in Malaysia were investigated. The result of this research revealed that when lights were off all surveyed buildings failed to meet the daylighting recommendation. In addition, all cases had unacceptable WPI distribution [43]. In addition, 100% of the surveyed area had average DF lower than 1.5%. Mean surface luminance were less than 30 cd m^{-2} , which is considered dark and mean luminance ratio was more than 40, which would cause glare problem [44].

The Energy Commission Diamond Building

The Energy Commission Malaysia is an energy-efficient office and was nominated as the sustainable building in Malaysia. The building is located in the commercial part

of Putrajaya, Malaysia. The diamond-shaped building provides a self-shading form as a passive design strategy (Figures 3–5).

An atrium at the centre of the building would allow sufficient daylight penetration for natural lighting purposes. The facade is integrated with internal light shelves to direct natural daylight deep into the office space (Figure 6) [45].

Materials and Methods

For measuring different lighting parameters such as WPI, relative daylight ratio, surface luminance and reflectance, the following materials and methods were used.

Materials and Equipments

Equipments used were as follow:

- Lux-meter sensor: LP 471 PHOT Probe – lux Meter Cosine Corrector- corrected for photopic vision $0.01 \text{ lux} - 200.10^3 \text{ lux}$.
- Luminance meter sensor: LP 471 LUM 2 Probe – Luminance Meter – Corrected for Photopic vision – measuring angle 2 degree – $0.1 \text{ cd.m}^2 - 2000.10^3 \text{ cd.m}^{-2}$.

Table 2. Lighting performance indicator [42]

# Performance indicator	Interpretation
1 Work plane illuminance <100 lx 100–300 lx 300–500 lx >500 lx	Too dark for paper and computer work Too dark for paper work/acceptable for computer work Acceptable for paper work/ideal for computer work Ideal for paper work/too bright for computer work
2 Illuminance uniformity on the work plane $E_{\min}/E_{\max} >0.5$ $E_{\min}/E_{\max} >0.7$	Acceptable Preferable
Performance indicator	Interpretation
Absolute luminance >2,000 cd m ⁻² >1,000 cd m ⁻² <500 cd m ⁻² <30 cd m ⁻²	Too bright, anywhere in the room Too bright, in the visual field Preferable Unacceptably dark
Luminance ratios $L_{VDT}/L_{surroundings} <0.1$ or >10 $L_{VDT}/L_{surroundings} <0.05$ or >20 $L_{paper_task}/L_{VDT} <0.33$ or >3 $L_{paper_task}/L_{surroundings} <0.025$ or >40	Unacceptable within 60° cone of vision Unacceptable within 120° cone of vision Unacceptable within whole visual field Unacceptable within 60° cone of vision Unacceptable within 120° cone of vision Unacceptable within whole visual field Unacceptable Unacceptable between points anywhere in the visual field
$L_{paper_task}/L_{surroundings} <0.33$ or >3 $L_{paper_task}/L_{surroundings} <0.1$ or >10 $L_{paper_task}/L_{surroundings} <0.05$ or >20 $L_{VDT}/L_{surroundings} <0.33$ or >3	
Daylight factor <1% 1–2% 2–5% >5%	Unacceptably dark, negligible potential for daylight utilisation Acceptable, small potential for daylight utilization Preferable, large potential for daylight utilization Ideal for paper work, too bright for computer work, total daylight autonomy



Fig. 3. Energy commission building in Malaysia. By: Mansour Nikpour.

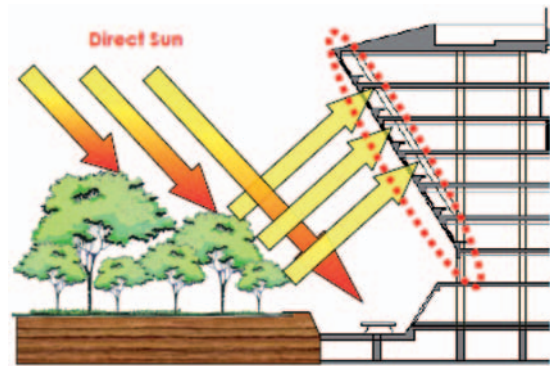

Fig. 4. Energy commission building in Malaysia (section). By: Ir. Mohd Fadzil & Gregers Reimann.

- Data logger: Photo/Radiometer HD 2102.2 – Model = prob-sicram phot.

A data logger, which is digital equipment that can be connected to different sensors and shows and records the amount of daylight, being transferred from the sensors. It can be connected to the lux-meter sensor as well as

luminance sensor. The date and times and interval between recording can be set manually. Furthermore, it has a special cable that enables connection to computer for setting and transferring recorded data. Measurement tape was used to measure the physical characteristics of rooms. Compass was used to specify the exact orientation of the room facing to the North.

Calibration Test

Calibration test was carried out to check the accuracy of all equipment. For this purpose, three illuminance sensors were located near each other as much as possible in a work plane. Each of the sensors was connected to a

data logger which was previously set with date, time and interval of recordings (Figure 7).

The recording of the illuminance work plane started and finished at a same time. As the interval between each recording was 10 min. Each data logger recorded 70

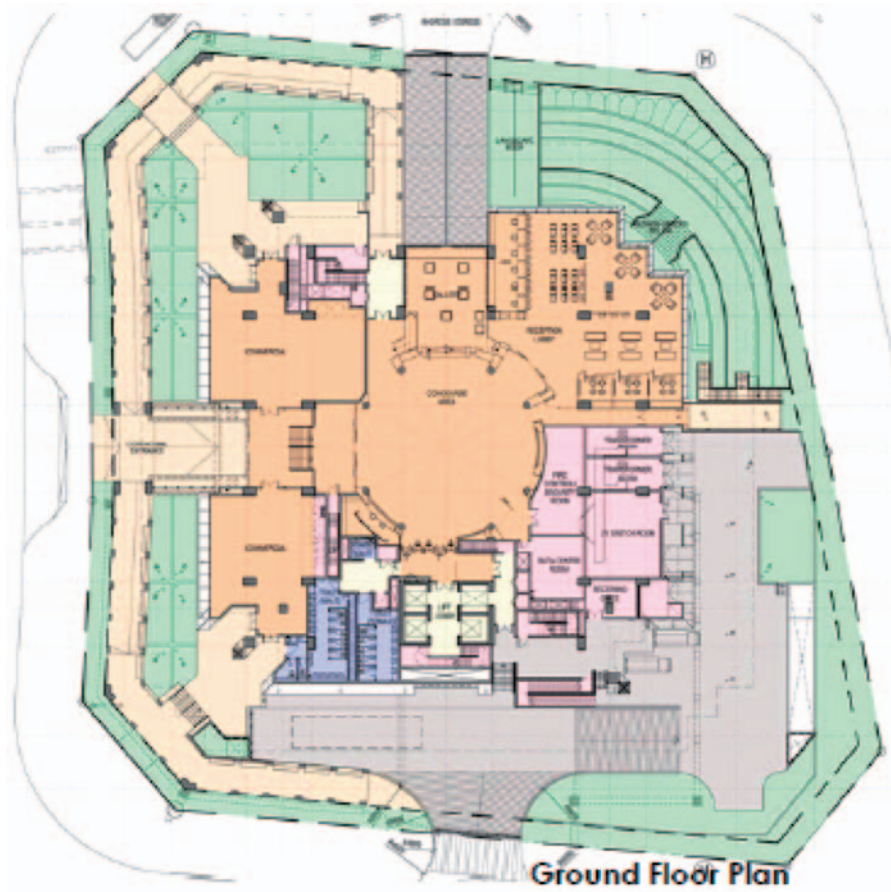

Fig. 5. Energy commission building in Malaysia (plan). By: Ir. Mohd Fadzil & Gregers Reimann.

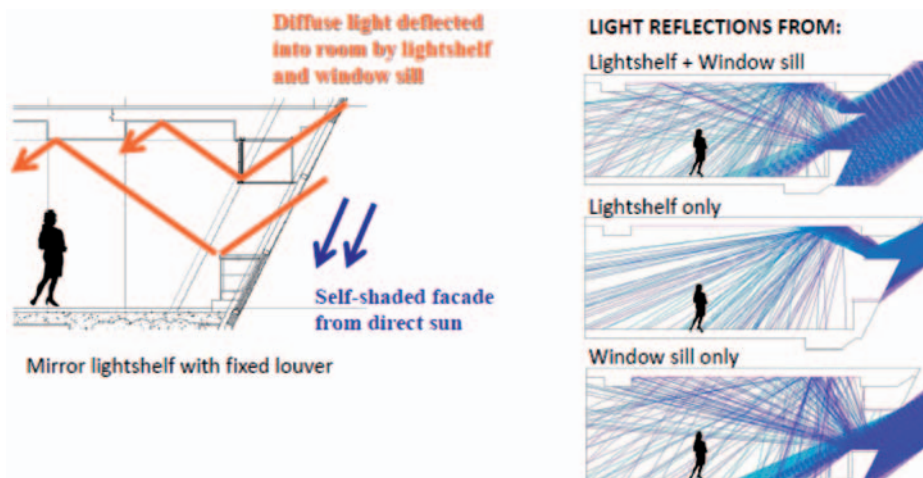

Fig. 6. Penetration of daylight deep into the office space by using light shelf. By: Ir. Mohd Fadzil & Gregers Reimann.

numbers of WPI during measurement. The measured data were assessed with Pearson correlation test using the SPSS software. The SPSS result demonstrated significant correlations between recorded data of three equipments. There was a very strong and positive correlation between recorded data illustrating that the equipments had worked accurately (Table 3).



Fig. 7. Calibration test for three set of equipments. By: Mansour Nikpour.

Equipment Installation

At first, date and time and 10-min interval between each recording were set, then one illuminance sensor was connected to a data logger and put them on roof top of the Energy Commission Diamond Building in Malaysia without any obstruction of solar radiation. By pressing the button “LOG,” the recording of outside illuminance was launched every 10 min. Recording outside illuminance was being continued until the indoor measurements were finished. The recording was stopped by pressing button “LOG” again.

Two individual office rooms on the 6th floor were selected for measurement. All physical characteristics of each room such as length, width, height, window size, projected ceiling with respect to floor were measured and the orientations of each room was specified by using a compass.

To measure the WPI for each room, the number and place of each sensor, room index were computed for each room as shown in equation (1).

$$\text{Room index} = \frac{(\text{lengths} \times \text{width})}{[\text{Mounting height} \times (\text{length} + \text{width})]} \quad (1)$$

The room index is required to know the minimum number of measuring positions from which average illuminance could be calculated.

The minimum numbers of measuring WPI for rooms were at least 9 points and 4 points, respectively. According to the room index of each room with respect to Table 4,

Table 3. SPSS result for calibration test

		Correlations		
		eq. one	eq. two	eq. three
eq. One	Pearson Correlation	1	1.000*	1.000*
	Sig. (2-tailed)		0.000	0.000
	Sum of Squares and Cross-products	1.350E8	1.417E8	1.476E8
	Covariance	1956966.865	2053656.232	2139493.745
	N	70	70	70
eq. Two	Pearson correlation	1.000*	1	1.000*
	Sig. (two-tailed)	0.000		0.000
	Sum of squares and cross-products	1.417E8	1.487E8	1.549E8
	Covariance	2053656.232	2155325.933	2245039.334
	N	70	70	70
eq. Three	Pearson correlation	1.000*	1.000*	1
	Sig. (two-tailed)	0.000	0.000	
	Sum of squares and cross-products	1.476E8	1.549E8	1.614E8
	Covariance	2139493.745	2245039.334	2339204.036
	N	70	70	70

*Correlation is significant at the 0.01 level (two-tailed).

the first room was divided by 9 (3 times 3) and the second room divided by 4 (2 times 2). One delta logger connecting to an illuminance sensor was placed at the centre of the divided area, on the height of work plane and then the WPI was recorded for each point concurrently at the exact time and also the exact time of measurement was recorded to compare the mean indoor illuminance with mean recorded outdoor illuminance at a same time. The WPI was measured for two conditions when lights were on and off.

Luminance sensor was connected to a data logger; then sensor was located in front of the centre of each wall in the room, ceiling, floor and window. For measuring luminance of each surface, the luminance of each surface was recorded when lights were on as well as when lights were off. The luminance of each surface was recorded in two conditions of lights in the survey form for further analysis.

The amount of illuminances were recorded while illuminance sensor was installed at 5.8 cm distance from each surfaces in two conditions when the sensor was located face to the surface and when the sensor was located reverse to the surfaces for calculating surface reflectance of each surfaces [44].

This design experiment was used for calculating the parameters of daylight such as mean WPI, relative to

daylight ratio, WPI ratio, surface luminance, surface luminance ratio and surface reflectance.

Results and Discussion

Physical characteristics of two surveyed rooms in the Energy Commission Diamond Building in Malaysia were measured and collected. These are shown in Tables 5 and 6 and in Figures 8–11.

WWR is defined as the ratio of the area of a window to the total gross wall area. WWR for room 1 was equal to 0.54 and for room 2, 0.61. The venetian blinds were in completely open position during all measurements.

Work Plane Illuminance

This experimental measurement was held on October 11, 2011, under intermediate sky. The mean external illuminance during measurement for each room is reported in Table 7. Table 8 shows the WPI for each point in each room when lights were off.

Table 8 shows that both rooms had a WPI of more than 600 lux. It means that both rooms could be considered ideal for paper work and too bright for computer work when lights were off. However, only three points (A1, B1, C1) were in this condition. Because these points were located at the nearest point in respect to the window compare to the other points. Other three points were located at the middle of the room (A2, B2, C2), which had a WPI of more than 300 lux. According to the Malaysian Standard 1525:2007 recommendation, the WPI between 300 and 500 lux is considered acceptable for paper work and ideal for computer work. The three other points (A3, B3, C3), which were located at the back of the room, had a

Table 4. Room index

Room index	Minimum number of measuring positions
Less than 1	4
1 to below 2	9
2 to below 3	16
3 or greater	25

Table 5. Physical characteristics of surveyed rooms

	Type	Floor level	Window orientation	No of occupants	Room plan shape	Geometry (W × L × H) (mm)
1	Individual	6	East (N10°)	1	Linear	6,650 × 5,000 × 3,600
2	Individual	6	East (N10°)	1	Linear	4,800 × 3,000 × 3,600

Table 6. Physical characteristics of surveyed rooms

Room no.	Physical characteristics of surveyed Rooms						
	Window height (mm)	Cill height (mm)	Window glazing	Internal shading	Ceiling height (mm)	Work plane height (mm)	Artificial lighting flourescent
1	2,150	900	Tinted	Venetian blind	3,600	850	4 (two tubes)
2	2,150	900	Tinted	Venetian blind	3,600	850	2 (two tubes)

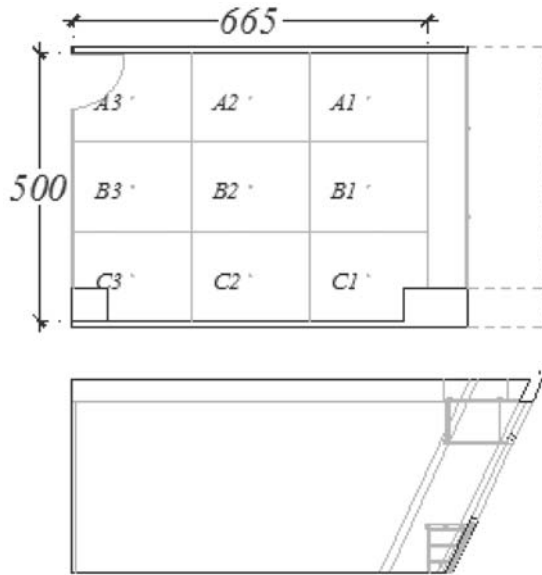

Fig. 8. Plan and section surveyed room No. 1. By: Mansour Nikpour.



Fig. 9. Surveyed room No. 1 (photo).

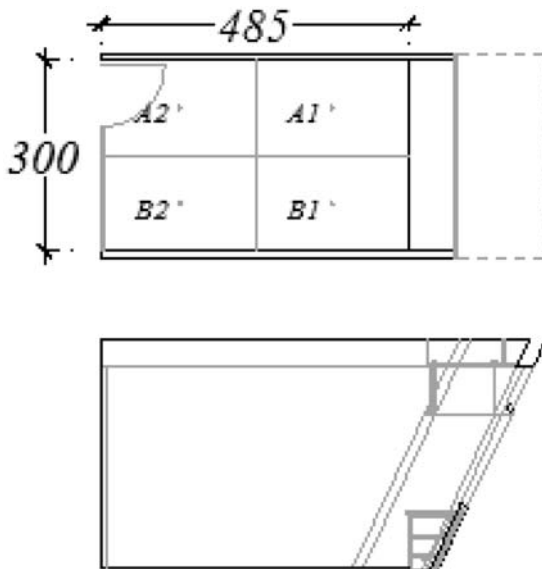

Fig. 10. Plan and section surveyed room No. 2. By: Mansour Nikpour.



Fig. 11. Surveyed room No. 2 (photo). By: Mansour Nikpour.

Table 7. Mean external illuminance during measurement

	Mean external illuminance (lux)
During measuring room 1	41,920.00
During measuring room 2	44,645.00

WPI of 148, 147 and 132 lux, respectively. However, the WPI between 100 to 300 lux is acceptable for computer work, but it is dark for paper work.

It means one third of first room with highest depth with respect to the window would need artificial lighting to reach the acceptable range for paper work and ideal range for computer work.

Measurement in room no. 2 shows that two points at the back of the room (A2 and B2) could not reach the minimum range of acceptable WPI of 300 lux. However, another two points (A1, B1) had a WPI of 1,015 and 915 lux, respectively. Table 9 shows the WPI of each point in each room in two conditions when lights were on.

In the room No. 1, 4 times 2 fluorescent tube lamps were installed but only 2 times 2 of them which were installed at the back can be controlled by manually switching on/off and another 2 were controlled by smart sensors automatically. The 2 times 2 fluorescent tubes were controlled by sensors, these were switched off during the measuring time. In addition, 2 times 2 fluorescent tube lamps were installed in room No. 2. The 1 times 2 fluorescent tubes were switched on by sensors and another one was switched on manually. As the amount of daylight especially in the half of the room closer to the room seemed high, at the time of measurement, 1 times 2 fluorescent tube lamps were switched off.

Table 8 reveals that both surveyed rooms had a mean WPI higher than 700 lux when lights were on. However, this amount of WPI would be ideal for paper work but was

Table 8. Work plane illuminance, WPI, lights off (lux)

Work plane illuminance, WPI, lights off (lux)										
Points	A1	A2	A3	B1	B2	B3	C1	C2	C3	Ave
Room 1	1,591.00	338.00	148.00	1,738.00	352.00	147.00	1,084.00	311.00	132.00	649.00
Room 2	1,055.00	267.00	—	915.00	242.00	—	—	—	—	619.75

Table 9. Work plane illuminance, WPI, lights on (lux)

Work plane illuminance, WPI, lights on (lux)										
Points	A1	A2	A3	B1	B2	B3	C1	C2	C3	Ave
Room 1	1,739.00	618.00	385.00	1,721.00	677.00	436.00	1,120.00	442.00	327.00	829.00
Room 2	1,062.00	522.00	—	818.00	476.00	—	—	—	—	719.50

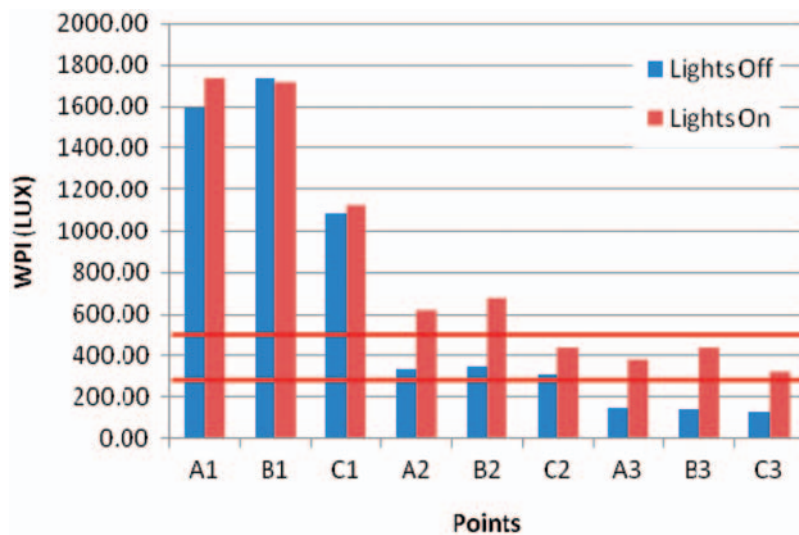

Fig. 12. Work plane illuminance, WPI, (lux) lights off and on in room No. 1.

too bright for computer work. In the first room only A3, B3, C2, C3 had a WPI lower than 500 lux, but the WPI was still above 300 lux. The WPI between 300 and 500 lux are considered acceptable for paper work and ideal for computer works. The points B3, C3, A3, with a greater distance from the window, were affected by lamps installed at the back of room which were on at the time of measurement. However, points A2, B2, C2 were at equal distance from the window, but C2 had a lower WPI with respect to A2 and B2 because C2 was influenced by the layout of the room. The presence of a steeped column was the reason for obstruction of the light at that point (Figure 12).

Only point B2 had a WPI between the range of 300 and 500 lux, which is acceptable for paper work and ideal for computer work. Other three points in room No. 2 received WPI more than 500 lux, which is ideal for paper work but is too bright for computer work. Therefore, this room usually has sufficient daylight available, except during rainy days when it is too dark. The lamps were controlled by sensors and would be kept off during working hours (Figure 13).

Work Plane Illuminance Ratio

Uniformity of daylight in each room is expressed in terms of WPI ratio. WPI is equal to minimum WPI

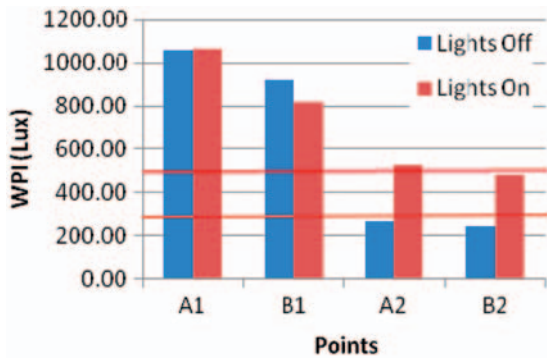

Fig. 13. Work plane illuminance, WPI, (lux) lights off and on in room No. 2.

Table 10. WPI ratio lights off and on

	Room 1	Room 2
Off	0.07	0.22
On	0.18	0.44

WPI: work plane illuminance.

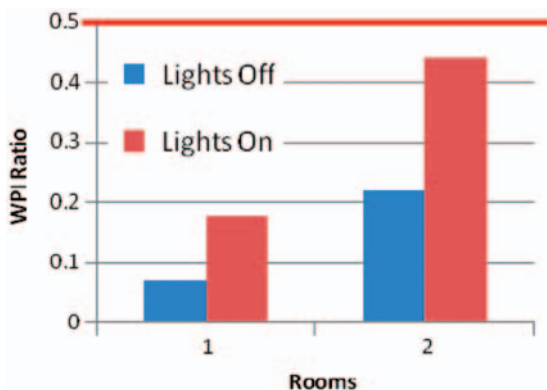

Fig. 14. Work plane illuminance (WPI) ratio lights off and on.

divided by maximum WPI in each room. The high differences between minimum and maximum WPI in each room shows there can be high contrast within the room. WPI ratio more than 0.7 is preferred and the WPI between 0.5 and 0.7 is considered acceptable and below 0.5 is not considered acceptable. WPI ratio of the two surveyed rooms for two conditions when lights were on and when lights were off were tabulated in Table 10.

Figure 14 shows when lights were off or on, none of the rooms achieved acceptable uniformity. WPI ratio became very close to the acceptable range with 0.44 in room No. 2 with artificial lightings.

Table 11. Daylight ratio in different point and average daylight ratio for two surveyed rooms

Points	Daylight ratio									
	A1	A2	A3	B1	B2	B3	C1	C2	C3	Avg
Room 1	3.79	0.80	0.35	4.14	0.83	0.35	2.67	0.74	0.31	1.50
Room 2	2.36	0.59	—	2.04	0.54	—	—	—	—	1.38

Daylight Ratio

The potential of each space for daylight utilization can be expressed in terms of daylight factor in overcast sky and relative daylight ratio in intermediate sky condition. The relative daylight ratio was computed by dividing the mean WPI of each space with the concurrently mean external illuminance as shown in equation (2).

Daylight Ratio

$$= (\text{internal illumination}/\text{external illumination}) \times 100 \quad (2)$$

According to MS1525, a space with a DF above 1.5 would have enough potential for daylight utilization. Table 10 shows the relative daylight ratios for different points of both surveyed rooms and the average of relative daylight ratio for each room separately. Room No. 1 achieved the acceptable range of daylight ratio. However, room No. 2 did not meet the acceptable range in terms of daylight ratio, but the existing range is very close to the acceptable range with 1.38% (Table 11).

Surface Luminance

The physical measure of the incentive, which provides the feeling of brightness in terms of the intensity of the light sent out in a given direction (usually towards the viewer) by unit area of a self-luminous or transmitting or reflecting surface, is defined as the luminance or the unit of luminance in Candela per square metre, cd m^{-2} .

Mean internal surface luminance of each room was calculated by taking the average of luminance of each surfaces of the room. As mentioned in the methodology, the luminance of four walls as well as ceiling and floor were recorded to compute average luminance of the room which shows the brightness of the room. The mean internal surface luminance would be acceptable if it was equal to 30 cd m^{-2} and above this range is considered preferable.

Tables 12 and 13 reveal that all surfaces in both rooms had surface luminance of more than 30 cd m^{-2} when lights were on except the opposite walls with respect to the

Table 12. Surface luminance for different surfaces lights on

Points	Surface luminance—light on (cd m ⁻²)						
	A	B	C	D	E	F	G
Room 1	1,022.60	116.10	102.20	149.00	61.00	92.00	23.60
Room 2	1,987.00	94.00	131.00	135.80	19.20	105.00	15.50

Table 13. Surface luminance for different surfaces lights off

Points	Surface luminance—light off (cd m ⁻²)						
	A	B	C	D	E	F	G
Room 1	920.00	128.00	70.00	51.00	52.00	94.00	13.60
Room 2	1,077.00	73.90	62.00	74.00	15.00	75.00	6.80

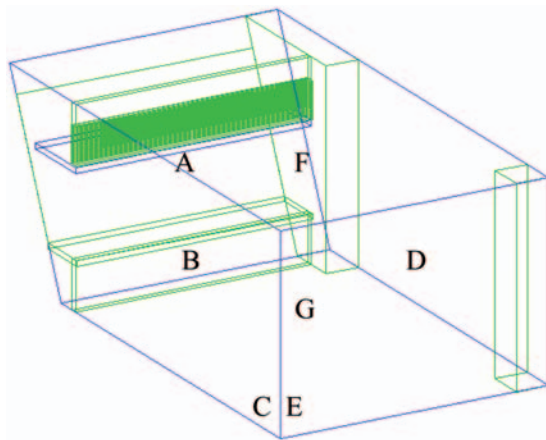

Fig. 15. Schematic perspective. By: Mansour Nikpour.

window which were made from glass, and floor surface in room No. 2 was carpeted and it was affected by furniture as well. Nonetheless, the average surface luminance for all surfaces in both rooms were in the preferable range both in two lights condition when lights were on and off.

Figure 15 is a schematic perspective showing the different surfaces of the room. The luminance is measured from the centre of each surface.

Test Point A is considered to be the centre of aperture, Test Point B is a wall with aperture, Test Point C is a wall on the left side when the viewer is standing against the window and Test Point D is a wall against test point C on the right side. Test Point E is considered a wall opposite the aperture, Test Point F is the ceiling and Test Point G is the floor.

However when lights were off, there were a reduction in the surface luminance for each surfaces and mean internal surface luminance comparing to the condition that lights

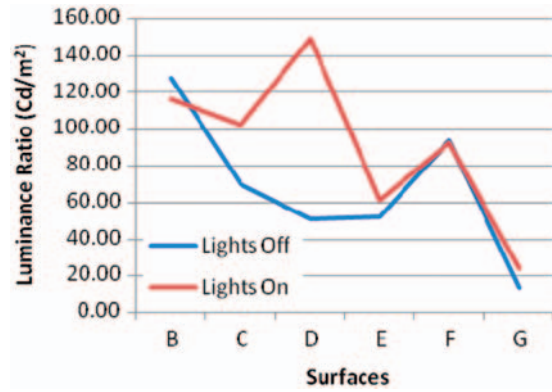

Fig. 16. Luminance ratio for different surfaces in room No. 1.

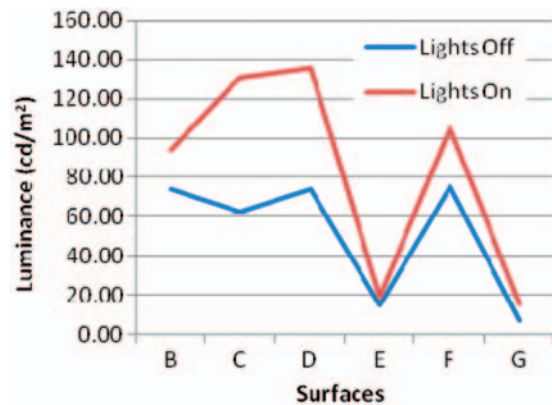

Fig. 17. Luminance ratio for different surfaces in room No. 2.

were on. But mean surface luminance remained in the preferable range above 30cd m⁻². Surface luminance for the opposite wall with respect to the window and surface luminance of the floor were lower than the acceptable range when lights were off, see Figures 16 and 17.

Surface Luminance Ratio

Luminance ratio can be calculated by dividing window luminance with the average internal surface luminance. This ratio shows the brightness contrast between window and other surfaces. The acceptable range for surface luminance ratio is below 40. Both the surveyed rooms in both conditions when lights were on and off achieved acceptable surface luminance ratio as recommended by the Malaysian standard, see Table 14 and Figure 18.

Surface Reflectance

Surface reflectance can show the amount of light admitted from a surface with respect to the amount of light which was received by the surface, therefore surface

Table 14. Surface luminance ratio lights on and off

Rmms	Surface luminance (cd m^{-2})					
	Lights on			Lights off		
	Window A	Avg (B, C, D, E, F, G)	Luminance ratio A/Avg	Window A	Avg (B, C, D, E, F, G)	Luminance ratio A/Avg
Room 1	1,022.60	123.00	8.30	920.00	68.00	13.50
Room 2	1,987.00	83.41	23.82	1,077.00	51.10	21.07

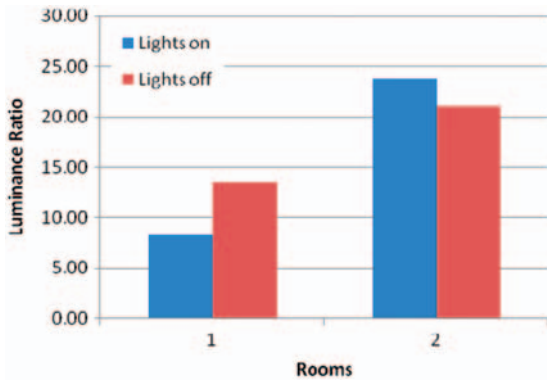
**Fig. 18.** Surface luminance ratio in rooms 1 and 2 when lights on and off.

reflectance was equal to recorded illuminance of each surfaces when the illuminance sensor were located facing to the surface divided by the recorded illuminance when the illuminance were located in reverse to the surface. The result should be multiplied by 100 to obtain the surface reflectance percentage. The acceptable range of surface reflectance for floor, wall and ceiling are 20%, 50% and 70%, respectively.

Surface reflectance for floor, wall and ceiling for the first surveyed room was 20%, 70% and 89%. It means that the first room met the IES recommendation in terms of surface reflectance definitely. In addition, surface reflectance in room no. 2 for wall and ceiling was above the acceptable range with 87% and 70%. As the floor-covering was carpet, the floor reflectance became lower than the recommended value (Table 15).

Conclusion

Self-shading strategy can have a significant impact on preventing direct solar radiation that could cause less heat gain. By applying this strategy, the amount of daylight that can penetrate inside the building would be reduced.

Table 15. Surface reflectance (%)

	Surface reflectance (%)		
	Wall	Floor	Ceiling
Room 1	0.70	0.20	0.89
Room 2	0.87	0.10	0.70

However, when some other strategies are applied, the mean WPI in 2 individual rooms attained an acceptable range and only one third of the area in the room No. 1 and half of the points in the room No. 2 could not reach to the acceptable range of WPI when lights were off. While a half of installed lamps were on, all points in both individual rooms met the recommendation value from WPI point of view. However, previous research revealed that 100% of offices in common office buildings had average DF lower than 1.5%. The relative daylight ratios in two office rooms in energy commission diamond building were within acceptable range. Average surface luminance and surface luminance ratios in both rooms were acceptable, in spite of common office rooms in Malaysia. All surfaces in both surveyed room gave acceptable surface reflectance except for the floor in room No.1. All parameters of daylight were within the acceptable range which implied that the performance of the both individual rooms were acceptable in term of daylight utilization except for WPI ratio which did not reach the acceptable range in both rooms and in both conditions when lights were off and when lights were on.

Finally, it can be concluded that a proper combination of strategies (self-shading, light shelf and venetian blind) can have a significant role for creating desirable environment based on daylight quality point of view as well as thermal comfort. The utilization of daylight in buildings can save energy. Furthermore, daylight is preferred by most people because of the contact with the outside world which is provided by windows. On the other hand, glare

and heat gains should be avoided. This can be achieved by careful control of solar radiation by using self-shading strategy.

Acknowledgement

The work is financed by International Doctoral Fellowship (IDF) provided by Universiti Teknologi Malaysia and the Ministry of Higher Education of Malaysia.

References

- 1 Chia SL: Minimizing Solar Insolation on High Rise Building in Malaysia. Johor, UTM, 2005.
- 2 Lam JC: Energy analysis of commercial buildings in subtropical climates: *Build Environ* 2000;35(1):19–26.
- 3 Iversen A, Nielsen TR, Svendsen SH: Illuminance level in the urban fabric and in the room: *Indoor Built Environ* 2011;20(4):456–463.
- 4 Sullivan R, Lee E, Selkowitz S: *Impact Assessment and Performance Targets for Lighting and Envelope Systems*. California, USA: Lawrence Berkeley Lab, 1992.
- 5 Lam JC, Hui S: Sensitivity analysis of energy performance of office buildings: *Build Environ* 1996;31(1):27–39.
- 6 Zain Ahmed A, Sopian K, Sayigh A, Surendran P: Daylighting as a passive solar design strategy in tropical buildings: a case study of Malaysia: *Energy Convers Manage* 2002;43(13):1725–1736.
- 7 Lam JC, Goodsall C: A survey of building envelope designs for commercial buildings in Hong Kong: *Build Res Informat* 1994;22(2):79–86.
- 8 Li DHW, Lam JC: Measurements of solar radiation and illuminance on vertical surfaces and daylighting implications: *Renewable Energy* 2000;20(4):389–404.
- 9 Li DHW, Lam JC, Wong S: Daylighting and its implications to overall thermal transfer value (OTTV) determinations: *Energy* 2002;27(11):991–1008.
- 10 Li DHW, Lam JC: Evaluation of lighting performance in office buildings with daylighting controls: *Energy Build* 2001;33(8):793–803.
- 11 Baker N, Steemers K: *Energy and Environment in Architecture: A Technical Design Guide*. London, Taylor & Francis, 2000.
- 12 Lam JC, Li DHW: An analysis of daylighting and solar heat for cooling-dominated office buildings: *Solar Energy* 1999;65(4):251–262.
- 13 Al-Tamimi NA, Fadzil SFD: Thermal performance analysis for ventilated and unventilated glazed rooms in Malaysia (comparing simulated and field data): *Indoor Built Environ* 2011;20(5):534–542.
- 14 Li DHW, Tsang EKW: An analysis of daylighting performance for office buildings in Hong Kong: *Build Environ* 2008;43(9):1446–1458.
- 15 Galasiu AD, Reinhart CF: Current daylighting design practice: a survey: *Build Res Informat* 2008;36(2):159–174.
- 16 Al-Sallal KA: Solar access/shading and building form: geometrical study of the traditional housing cluster in Sana'a: *Renewable Energy* 1996;8(1–4):331–334.
- 17 Kim JT, Kim G: Advanced external shading device to maximize visual and view performance: *Indoor Built Environ* 2010;19(1):65–72.
- 18 Lim HS, Kim G: Predicted performance of shading devices for healthy visual environment: *Indoor Built Environ* 2010;19(4):486–496.
- 19 Newsham G: Manual control of window blinds and electric lighting: implications for comfort and energy consumption: *Indoor Built Environ* 1994;3(3):135–144.
- 20 Knowles RL: The solar envelope: its meaning for energy and buildings: *Energy Build* 2003;35(1):15–25.
- 21 Aksoy UT, Inalli M: Impacts of some building passive design parameters on heating demand for a cold region: *Build Environ* 2006;41(12):1742–1754.
- 22 Adamskin M: Optimization of the form of a building on an oval base: *Build Environ* 2007;42(4):1632–1643.
- 23 Ratti C, Raydan D, Steemers K: Building form and environmental performance: archetypes, analysis and an arid climate: *Energy Build* 2003;35(1):49–59.
- 24 Kumar K, Tiwari K, Jha MK: Design and technology for greenhouse cooling in tropical and subtropical regions: a review: *Energy Build* 2009;41(12):1269–1275.
- 25 Chia SL, Ahmad MH, Ossen DR: The effect of geometric shape and building orientation on minimizing solar insolation on high-rise buildings in hot humid climate: *Construct Develop Countries* 2007;12(1):27–38.
- 26 Okeil A: A holistic approach to energy efficient building forms: *Energy Build* 2010;42(9):1437–1444.
- 27 Oral GK, Yilmaz Z: Building form for cold climatic zones related to building envelope from heating energy conservation point of view: *Energy Build* 2003;35(4):383–388.
- 28 Tzikopoulos A, Karatza M, Paravantis J: Modeling energy efficiency of bioclimatic buildings: *Energy Build* 2005;37(5):529–544.
- 29 Capeluto IG: Energy performance of the self-shading building envelope: *Energy Build* 2003;35(3):327–336.
- 30 Lam JC, Tsang C, Li DHW, Cheung S: Residential building envelope heat gain and cooling energy requirement: *Energy* 2005;30(7):933–951.
- 31 Chirarattananon S, Nooritanon J, Balaka R: Daylighting for energy conservation in the tropics: the lumen method and the OTTV: *Energy* 1996;21(6):505–510.
- 32 Lam JC, Li DHW: Daylighting and energy analysis for air-conditioned office buildings: *Energy* 1998;23(2):79–89.
- 33 Li DHW, Lam JC: Measurements of solar radiation and illuminance on vertical surfaces and daylighting implications: *Renewable Energy* 2000;20(4):389–404.
- 34 Yeang K: *Bioclimatic Skyscraper*. London, Artemis London Limited, 1996.
- 35 Ibrahim N, Zain Ahmed A: A Simple Prediction Tool for Energy Savings due to Daylighting in Malaysia: *Sci Technol* 2006;2(1):25–29.
- 36 Ossen DR, Ahmad MH, Madros NA: Optimum overhang geometry for building energy saving in tropical climates: *Asian Architect Build Engineer* 2005;4(2):563–570.
- 37 Lim YW, Ahmad MH, Ossen DR: Effect of solar shading fenestration and room geometry on office building energy efficiency in hot humid tropic: In *Proceedings of 3rd International Conference on Built Environment in Developing Countries, Penang, Malaysia, 2–3 December 2009*, pp. 174–185.
- 38 Ghisi E, Tinker JA: An ideal window area concept for energy efficient integration of daylight and artificial light in buildings: *Build Environ* 2005;40(1):51–61.
- 39 Tzempelikos A, Athienitis AK, Karava P: Simulation of façade and envelope design options for a new institutional building: *Solar Energy* 2007;81(9):1088–1103.
- 40 Lim YW, Ahmad MH: Daylight and users' response in high rise open plan office: a case study of Malaysia: In *Proceedings of 3rd International Graduate Conference on Engineering, Science, and Humanities, Johor, Malaysia, 2–4 November 2010*, pp. 30–39.
- 41 MS1525: Malaysian Standard: Code of Practice on Energy Efficient and Use of Renewable Energy for Non-Residential. Malaysia, Buildings Department of Standard, 2007.
- 42 Dubois MC: *Impact of Solar Shading Devices on Daylight Quality*. Lund, Lund University, 2001.
- 43 Kandar MZ, Sulaiman MS, Razidah RY, Ossen DR, Aminatuzuhariah MA, Lim YW, Nikpour M: Investigating daylight quality in Malaysian government office buildings through daylight factor and surface luminance: In *Proceedings of International Conference on Ecosystems, Environment and Sustainable Development, Venice, 2011*.
- 44 Kandar MZ, Razidah RY, Sulaiman MS, Ossen DR, Ahmad MH, Lim YW, Nikpour M: Survey of surface reflectance, WPI level and uniformity in Malaysian government office buildings: In *Proceedings of International Conference on Ecosystems, Environment and Sustainable Development, Venice, Italy, 28–30 November 2011*, pp. 3330–3334.
- 45 Zain Ahmed A: *Climate Change, Green Technology and Sustainable Buildings*. Shah Alam, University Publication Centre (UPENA), 2009.