

Carbon Capture and Storage from the Boiler to the Fleet – A Canadian Case Study

Peter L. Douglas^{*1}, Eric Croiset¹, Ali Elkame¹, Colin Alie¹, Ahmed Shafeen² and Haslenda Hashim³

³Faculty of Chemical and Natural Resources Engineering, Department of Chemical Engineering,
Universiti Teknologi Malaysia, 81310 UTM Skudai, Johor Darul Takzim, MALAYSIA.

²CANMET Energy Technology Centre, Natural Resources Canada, 1 Haanel Drive, Ottawa, Ontario K1A 1M1 CANADA

¹Department of Chemical Engineering, University of Waterloo, 200 University Avenue West, Waterloo, Ontario N2L 3G1,
CANADA

Abstract

This paper presents a techno-economic analysis of the capture and storage of CO₂ from a single coal fired boiler with extensions to a fleet of coal, natural gas, nuclear, hydroelectric and wind generating stations. AspenPlus™ was used to simulate a 500 MW coal boiler c/w steam cycle and MEA absorption process. The energy required by the absorption process resulted in a ~30% de-rate in the generating station output. 14,000 tonnes/day of pure CO₂ captured and compressed from the boiler was transported and injected into a saline aquifer approximately 125 km from the generating station and at least 800 m beneath the earth's surface under supercritical conditions, (31.1°C, 7.38 MPa). The cost to transfer CO₂ from the boiler and inject it underground is ~10 US\$/tonne of CO₂. The extension from a single boiler to the entire fleet of generating stations was formulated as an MILP and implemented in GAMS. A 3% fleet-wide reduction in CO₂ emissions was achieved by fuel-balancing alone. Deeper reductions, however, required a combination of CO₂ capture and storage, fuel-switching and new capacity including IGCC, NGCC and nuclear. For example, the cost of electricity increased by ~59% when reducing the fleet-wide emissions by 60%.

Keywords: carbon capture and storage, MEA absorption, fleet-wide optimisation

1.0 Introduction

CO₂ is the main greenhouse gas and is suspected to be the principal gas responsible for global warming and climate change. Fossil fuel power generation plants are being challenged to comply with the Kyoto Protocol developed by the United Nations Framework Convention and Climate Change (UNFCCC). For Canada, the Kyoto Protocol prescribed a legally binding greenhouse gas emission reduction target of 6 % below the 1990 level by 2008-2012.

Ontario Power Generation (OPG) produces 70% of the electricity for the Province of Ontario, Canada. Approximately 28.5% of OPG's electricity is produced through the combustion of fossil fuels, 27% from hydroelectricity, 44% nuclear and the remaining 0.5% comes from renewable or other energy sources, such as wind turbine. In 2002, OPG had about 22,211 MW total in-service capacity, generated about 115.8 TWh of electricity and emitted approximately 36.7 million tonnes (Mt) of CO₂, mainly from coal-fired power plants.

* Corresponding author: Tel: +1-519-888-4601, Fax: +1-519-888-5365, Email: pdouglas@cape.uwaterloo.ca

There are several possible strategies to reduce the amount of CO₂ emitted from fossil fuel power plants. Potential approaches include: increasing power plant efficiency, load balancing, fuel switching, enhanced use of renewable energy (i.e. wind turbines, solar, biomass, and fuel cells) and CO₂ capture and storage (CCS).

This paper presents an overview of CCS applied to a case study involving OPG's fleet of generating stations in Ontario, Canada. The first section deals with CO₂ capture from a 500 MW coal fired boiler at OPG's Nanticoke Generating Station. The second section deals with the geological storage of the CO₂ captured from the 500 MW coal fired boiler. The last section examines how one might mitigate CO₂ emissions for OPG's fleet of 69 generating stations.

2.0 Materials and Methods

2.1 CO₂ Capture from a 500 Mw Coal Fired Boiler

There are several approaches to the capture of CO₂ from a fossil fuel generating station [1]. The capture of CO₂ from the flue gas of natural gas/coal-fired power plants, using a monoethanolamine (MEA) absorption process, Figure 1, is considered to be a viable technology for the capture of CO₂ emissions from large point sources.

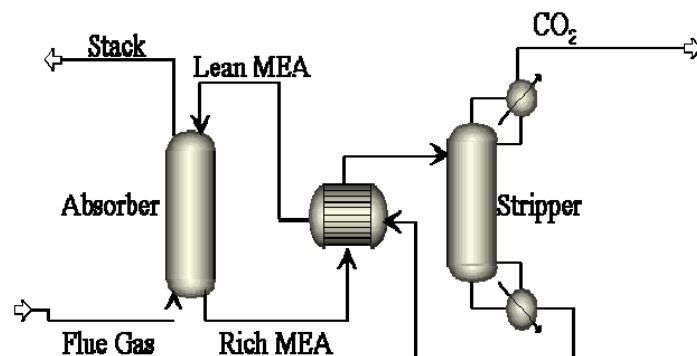

Figure 1 Basic MEA Absorption Process for CO₂ Capture

The flue gas enters the absorber and contacts an aqueous solution of MEA flowing counter-currently to the flue gas stream. CO₂, a weak base, reacts exothermically with MEA, a weak acid, to form a water-soluble salt. The 'rich'-MEA stream exits the absorber at the bottom of the column. It is then preheated in a heat exchanger by the lean-MEA stream leaving the stripper, and enters the stripper where, with the further addition of heat, the reaction is reversed. The CO₂ is then liberated from the MEA and leaves through the top of the column. The 'lean'-MEA is then recycled back to the absorber. Several researchers have modelled this process, [1-6]. It has been shown that the operating costs of the capture plant, in particular the energy required by the stripper reboiler, overshadow the annualized capital costs, [1, 2]. Therefore, when applied to flue gas from coal-fired power plants, minimizing the reboiler heat duty is important in this process. Besides the development of more efficient solvents, process simulation and evaluation are critical steps to maximize the performance of the process. Three hypothetical flue gas compositions were used: CO₂ concentrations of 3%, 14% and 25%, representative of natural gas power plant, coal power plant, and cement plant, respectively. For simplification, the balance of the flue gas was assumed to be nitrogen. In

each case, the flow rate of flue gas was kept constant at 70,000 kmol/h. Such a flow rate for the case of 14% CO₂ is similar to the flue gas flow rate from a 500 MW coal-fired power plant. The recovery of CO₂ was specified to be 85% with a product purity of 98%. The recovery is somewhat arbitrary; it is a reflection of how aggressively one wants to reduce the CO₂ emissions from the power plant. A minimum product purity of 98% is required for use in enhanced oil recovery and geological storage. Simulations were performed using Aspen Plus version 11.1 [7].

The emissions from a 500 MW coal fired power plant is assumed to be approximately 10,000-14,000 t/d. Figure 2 shows the dependence of Q_{reb} on α_{LEAN} for CO₂ concentrations of 3%, 14% and 25% using an inlet temperature of 80°C for the ‘lean’ MEA stream [5, 6].

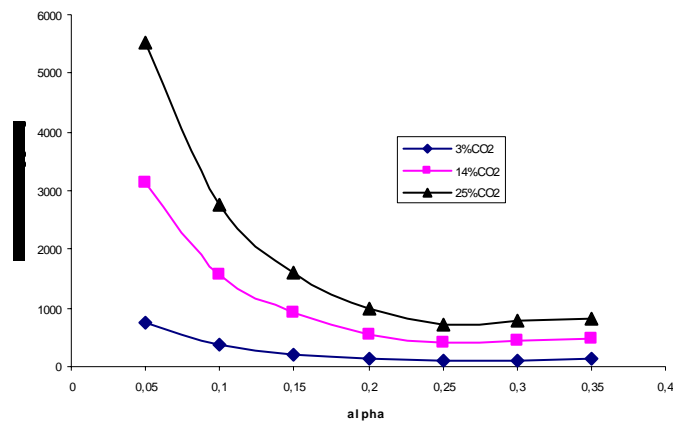

Figure 2 Reboiler duty vs. α_{LEAN} at $T_{inlet} = 80^{\circ}\text{C}$ for all CO₂ inlet concentrations

The heat duty in the reboiler, Q_{reb} , decreases as α_{LEAN} is increased up to 0.25 mol CO₂/mol MEA and then increases when α is increased from $\alpha=0.25$ to $\alpha=0.35$. As α_{LEAN} increases L_{min} also increases resulting in a feed stream to the stripper that contains much more CO₂ than the 85% that we need to recover. As a result the split in the stripper is less energy intensive resulting in a lower reflux ratio and reboiler duty. However, as α_{LEAN} continues to increase, resulting in an ever increasing flow rate, L , the heat needed to reboil this stream becomes predominant. The minimum reboiler heat duty was obtained when $\alpha_{LEAN} = 0.25$ for all CO₂ concentrations studied. This minimum is perceived to be a balance between the decrease in Q_{reb} with an increasing number of trays, and the decrease in Q_{reb} with increasing α_{LEAN} up to 0.30. For all CO₂ concentrations, the minimum reboiler duty occurs at a lean MEA loading of ~0.25 at an inlet temperature of 80°C. This information implies that a few design principles can be applied for a MEA CO₂ capture plant regardless of the flue gas composition.

As one can see from Figure 2 the heat required by stripper in the MEA process, Q_{reb} , is significant; the minimum reboiler heat duty for the 500 MW_e coal fired boiler is ~420 MW_{th}. In addition, ancillary equipment (blowers and compressors) require ~50 MW_e. This results in a significant de-rate or reduction in the net output from generating station. Little attention has been paid to how to provide this parasitic energy to the MEA plant. A complete study requires the simulation of the generating station's steam cycle along with the MEA process [6]. Figure 3 shows the complete flowsheet incorporating the coal fired boiler, MEA capture process and steam cycle.

The integration of the coal combustion, steam cycle, and MEA absorption process results in significantly more complex process. The so-called ‘IP/LP crossover pipe’ in the steam cycle is the preferred extraction location from which to extract steam for Stripper reboiler as it is easily accessible and furnishes steam at conditions relatively close to those required; approximately 65% of the steam was extracted to run the reboiler.

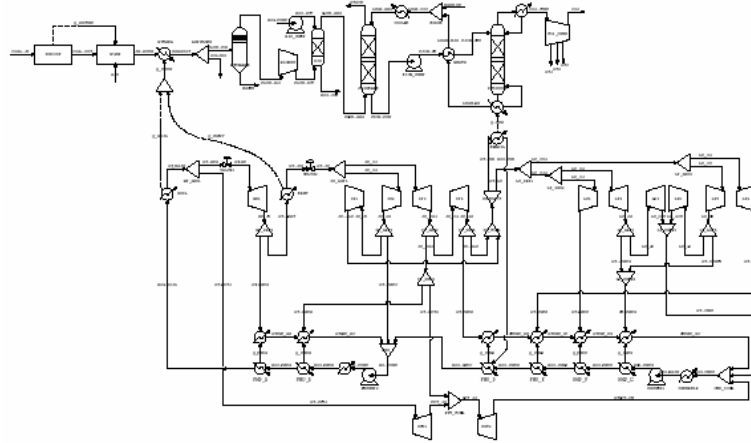

Figure 3 Integration of coal fired boiler, MEA capture process and steam cycle

An optimisation study resulted in the following results [6]:

α_{lean}	0.25	mol CO ₂ /mol MEA
$N_{Absorber}$	2	trays
$N_{Stripper}$	7	trays
x_{steam}	0.64	
E_{net}	342	MW _e
de-rate	31.2	[%]

A de-rate of 31.2% implies that 31.2% more generating capacity will be needed to ensure that the current demand is met and the cost of electricity may be assumed to increase by ~30%.

2.2 Geological Storage of CO₂ from 500 Mw Coal Fired Boiler

The CO₂ captured from the 500 MW boiler must be safely stored for long geological periods, from hundreds to thousands of years. Geological storage in saline aquifers is considered to be a viable option. The concept is to inject CO₂ into a porous and permeable reservoir covered with a cap rock located at least 800 m beneath the earth’s surface where CO₂ can be stored under supercritical conditions [8]. The injection pressure and temperature should be above the critical temperature and pressure of CO₂ (31.1°C and 7.38 MPa).

Two major reservoirs close to the Nanticoke Generating Station were identified. Figure 4 shows the Province of Ontario and Figure 5 shows the northern zone (NZ) and southern (SZ) with approximate storage capacities of 289 MMtons and 442 MMtons respectively [9, 10].

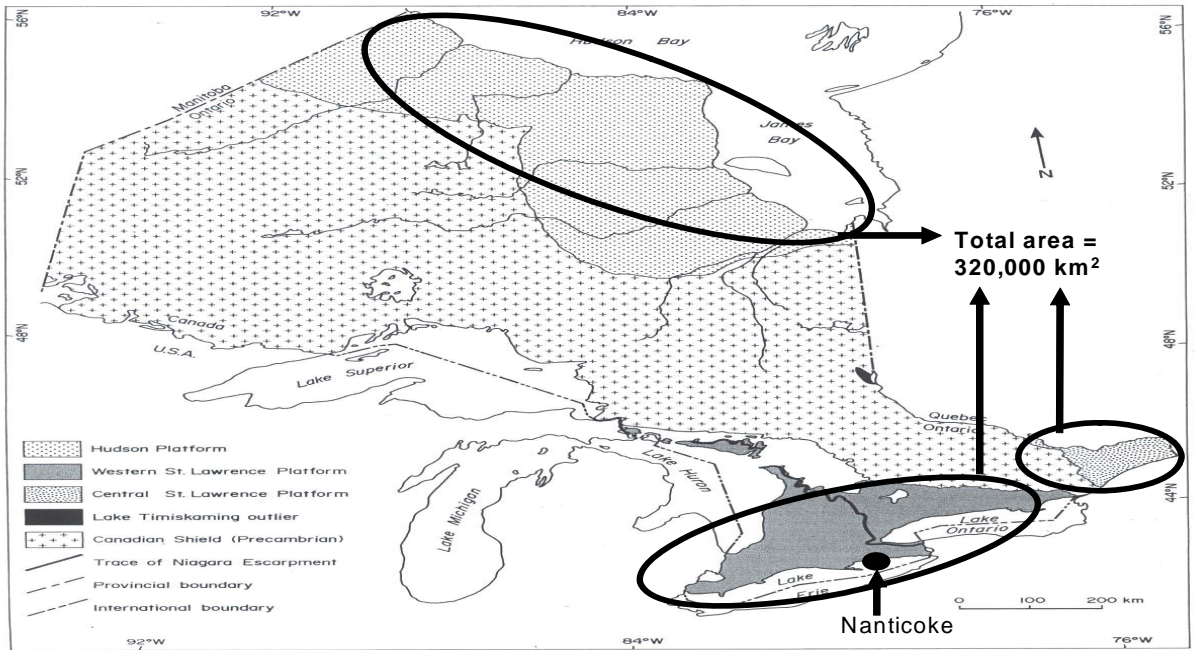

Figure 4 Province of Ontario showing three saline aquifers

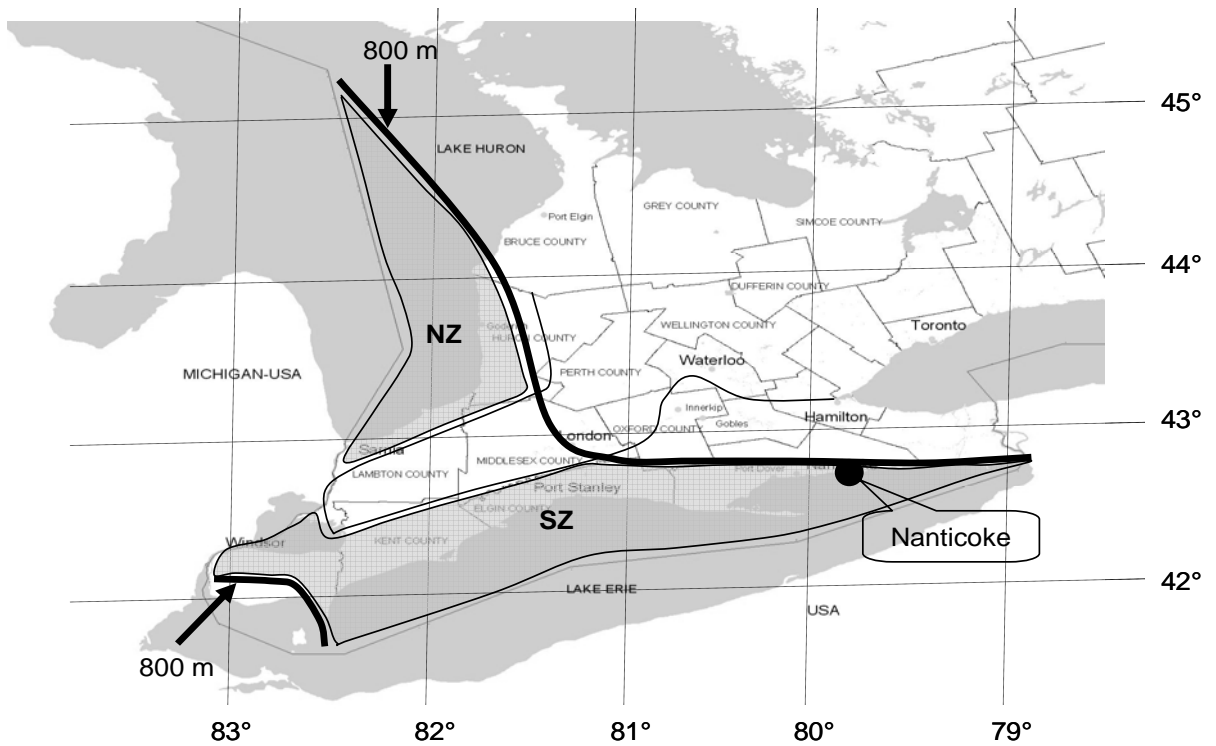

Figure 5 Southern Ontario showing Nanticoke Generating Station and NZ and SZ

The estimate of storage capacity is sensitive to the values of porosity, permeability, sweep efficiency, solubility and CO₂ saturation. Based on the available data for porosity, a sensitivity analysis is carried out to observe the effect on the overall reservoir capacity. The upper and lower limits are estimated to be 5% and 25%. With the increasing porosity the capacity of the reservoir increases and similarly decreases with the decreasing values. The reserve capacity might vary from 220 to 1104 MMtons which represents 10 to 50 years of current emission from the entire Nanticoke Generating Station or power plant or 80 to 400

years from a single 500 MW boiler. Sweep efficiency will also produce exactly the same result as the porosity if varied from 5 to 25%. If it is possible to reach 50%, the reserve could be more than 2200 MMton of CO₂.

There are two possible routings for the hypothetical pipeline. One is a 150 km onshore-offshore route; the onshore part will be 100 km and a 50 km offshore to the injection point. The other option is a 112 km offshore route direct to the injection point in the centre of Lake Erie from Nanticoke.

The capital cost can be divided into cost of transportation and storage, (the CO₂ compression cost is considered part of the capture cost and not the sequestration cost). The cost of transportation includes the cost of the pipeline; the cost of storage includes the cost of the injection system including the injection wells and platforms. The pipeline cost is a function of pipe diameter, pipeline inlet pressure, booster compressors, type of terrain and water depth. Some authors have used an offshore:onsshore ratio of 1:1 whereas others have suggested 3:1 [12]. Storage costs for offshore reservoirs are also typically 50% higher [13]. Injection at offshore locations increase the cost as it involves installing the offshore platforms associated with higher well drilling cost [12]. Water depth also plays an important role in cost estimation. The shallow depth of Lake Erie will play a positive role in keeping the cost to a minimum.

Pipeline costs are estimated to be US\$750/m (onshore) and US\$1,000/m (offshore) [13]. The total cost of the main components of a 112 km offshore pipeline is ~US\$257 million. For the case of a 150 km onshore/offshore pipeline, using a unit cost of US\$750/m for the onshore segment, the total cost varies from US\$270 million to US\$333 million.

The cost of drilling each injection well including wellheads and/or submerged equipment is assumed to be US\$4,000 per meter of reservoir depth for shallow water less than 100 m [12]. This results in a cost of an injection well of US\$4.5 million; this agrees well with values reported by Hendriks and Block [13]. The estimated unit cost of an unmanned well-head platform with 10 injection wells would be US\$4 million per meter water depth for the shallow water case [12].

The annual operating cost of the sequestration project can be approximated at 5 to 10% of the total pipeline cost [12]. Using 7.5%, the annual cost will be ~US\$20 million for a capital cost of US\$257 million pipeline. For a storage rate of 14,000 tonnes/day and assuming a 5% interest rate and 25 years repayment period the amortized value of US\$257 million investment along with the annual operating cost of US\$20 million/year will be ~US\$7.5/ton of CO₂.

Uncertainties are associated with the reservoir capacity calculation, determination of injection well capacity and cost estimation for sequestration including: the nature of the reservoir, sweep efficiency, injection process and routing of the pipeline. Existing network of pipelines on the lake bed could pose an obstacle for laying the pipeline. Uncertainty related to the sweep efficiency should be overcome in order to better predict the reserve capacity of the formation. Uncertainties in the reservoir condition during injection process could lead to drill additional wells or platforms and might increase the capital cost. Impurities in CO₂ flow stream can reduce the transportation capacity of the pipeline. A capacity reduction of 20% can be encountered due to the presence of impurities such as CH₄, N₂ and H₂. The sensitivity of cost to pipeline, injection depth, injection capacity per well, number of wells and reservoir

behaviour plays an important role in cost estimation. The requirement of a booster compressor may add significant costs to the overall capital expenditure.

After all uncertainties are taken into account, the overall capital investment for the sequestration project in lake Erie would be from US\$260 to US\$500 million which is equivalent to 7.5-14 US\$/ton CO₂ [9, 10].

2.2 Fleet-Wide Emissions

The costs to capture and store CO₂ from one 500 MW coal fired boiler at OPG's Nanticoke Generating Station have been estimated. However, the mitigation of CO₂ from a fleet of generating stations in a region such as the Province of Ontario has not been considered.

Figure 6 is a so-called superstructure diagram representing the fleet of existing and proposed generating stations for OPG. C, NG, O, N, H and A represent the set of coal, natural gas, oil, nuclear, hydroelectric and alternative energy power plants, respectively. The problem posed here is formulated as: "for a given CO₂ reduction target, what is the best generating station load and mix of fuels, while maintaining the electricity supply to the grid?"

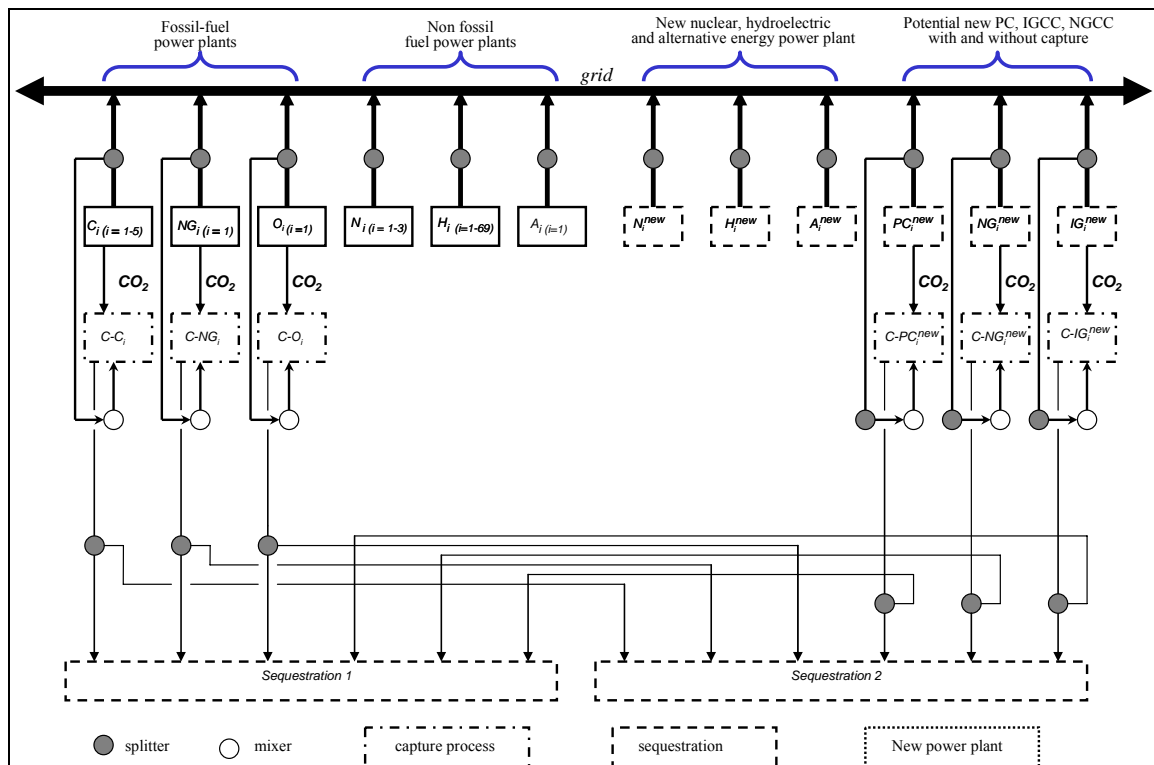

Figure 6: Superstructure for OPG's existing/proposed fleet of generating stations

The objective is to determine the minimum cost of generating electricity while satisfying a CO₂ reduction target (likely imposed by government regulations) and satisfy electricity demand. The cost of electricity (COE) includes the costs of:

- generating electricity from the current fleet of generating stations
- retrofits associated with switching from coal to natural gas ins some generating stations
- new generating stations
- CO₂ capture and storage.

The minimization of the cost of electricity is subject to the following major constraints:

- the total electricity generation must be \geq the electricity demand
- the increase in the electricity generated from a particular unit must be \leq a maximum increase in the base load based on operational limits
- the load factor for each unit must be \geq a minimum; otherwise the plant will be shut down
- annual CO₂ emissions must be \leq a specified target.

Currently, OPG operates 79 generating stations with a nominal capacity of 13,765 MW; 5 are coal fired, C($i=1-5$), 1 is natural gas, NG($i=6$), 3 are nuclear, N($i=7-9$), 69 are hydroelectric, H ($i=10-78$), and 1 is a small wind turbine, A($i=79$). No CO₂ capture processes currently exist at any OPG generating station and about 36.7 million tonnes of CO₂ was emitted in 2002, mainly from fossil fuel power plants. Therefore, we will assume that all the CO₂ is emitted from the 27 fossil fuel boilers at 6 fossil fuel stations: 4 boilers at Lambton (L1-L4), 8 at Nanticoke (N1-N8), 8 at Lakeview (LV1-LV8), 1 at Atikokan (A1), 4 at Lennox (L1-L4) and 2 at Thunder Bay (TB1-TB2). A summary of OPG's fossil fuel generating stations is contained in Table 1.

Table 1 OPG's fossil fuel generating stations

Station	Fuel	Installed Capacity (MW)	Number of units	Annual capacity factor	Operational cost (\$/MWh)	CO ₂ emission rate (tonne/MWh)
Nanticoke-1 (N1)	Coal	500	2	0.75	20	0.9300
Nanticoke-2 (N2)	Coal	500	6	0.61	20	0.9300
Lambton1 (L1)	Coal	500	2	0.5	22	0.9386
Lambton2 (L2)	Coal	500	2	0.75	17	0.9384
Lakeview (LV)	Coal	142	8	0.25	23	0.9765
Lennox (LN)	Gas	535	4	0.15	47	0.6510
Thunder Bay (TB)	Coal	155	2	0.55	20	1.0230
Atitokan (A)	Coal	215	1	0.44	20	1.0230

The operational cost for nuclear was estimated to be \$32/MWh, hydroelectric was estimated at \$5/MWh and wind turbine was estimated to cost \$4/MWh; Currently, natural gas is the most expensive fuel used by OPG [14]. In this study, we assumed that all coal-fired boilers operate at 35% efficiency and that the base load demand is constant throughout the year at 13,675 MW. The retrofitting cost was estimated to be \$30 million/1000 MW with a 20 year lifetime and 10% annual interest rate. The reserve margin, for load distribution for all OPG's fleet power plants is set at 1% higher than current level. The lower bound was set to be 10% (i.e. a plant must be operated at least with 10% of its installed annual capacity factor; otherwise it will be shut down). Figure 7 provides a summary of the electricity currently generated from the 27 boilers at OPG's fossil fuel generating stations; currently only four boilers are operating on natural gas.

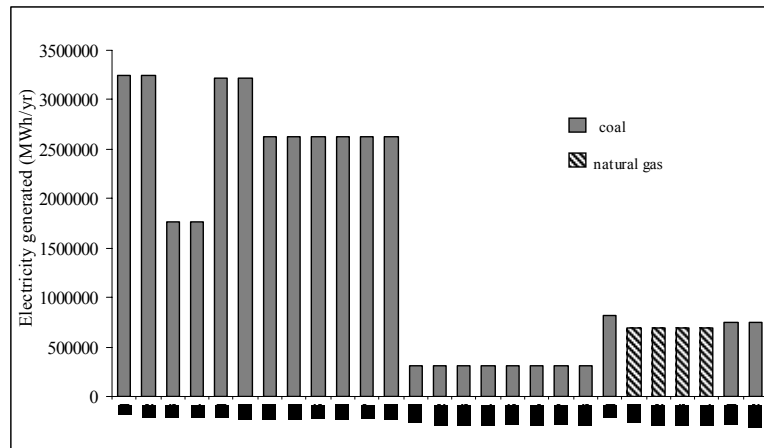

Figure 7 OPG's current (2004) fossil fuel boilers

The models were implemented in the GAMS (General Algebraic Modeling System) optimization package and solved using the Mixed Integer Linear Programming (MILP) solver [15 - 17]. The objective is to minimise the total operating cost while meeting a specified CO₂ reduction target.

The optimization results showed that a 3% CO₂ reduction can be achieved by increasing the load on existing non fossil power plants and decreasing load from existing fossil power plants (fuel balancing). However, in order to achieve more than 3% CO₂ reduction, it was found that fuel switching must be implemented. Canada's emissions will rise to approximately 750 Mt by 2005 from 571Mt in 1990. Therefore, the actual reduction target is to reduce emissions to 179 Mt by 2008-2012 and this represents more than 20% reduction [18]. Figure 8 shows that 9 out of 23 coal fired boilers should be switched to natural gas to achieve a 20% CO₂ reduction and resulting in an 8.3% increase in the COE.

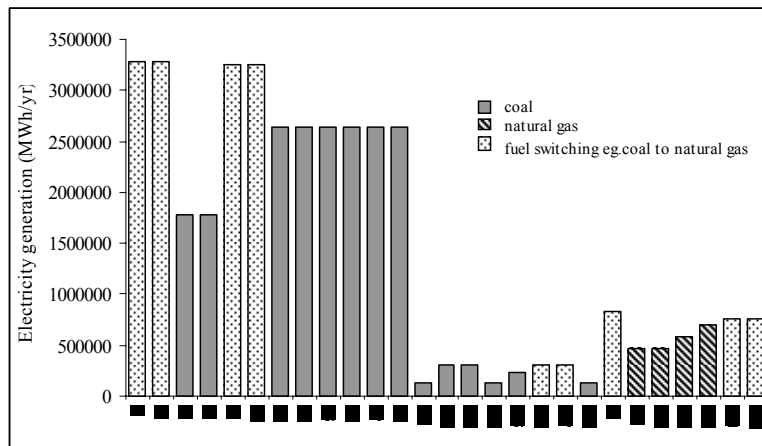

Figure 8 Electricity generation strategy by fossil fuel boilers for a 20% CO₂ reduction

To achieve deep CO₂ reduction targets (e.g. 60% CO₂ reduction), structural changes are required to be implemented on the fleet, for example carbon capture and storage and or new generating stations. In the case of a 60% reduction, the optimal structure of the fossil fuel generation stations is shown in Figure 9. Carbon capture was incorporated on one of the largest coal-fired boilers, (N1) and the captured CO₂ was transported to Lake Erie for storage. Nine new NGCCs (two-334 MW, three-403 MW, three-517 MW and one-750 MW with capture)

are added to the fleet. In addition, the optimizer chooses to shut down 16 coal fired boilers; 8 at Lakeview (LV1 – LV8) , 1 at Lambton (L1), 7 at Nanticoke (N2, N3, N4, N5, N6, N7, N8), 1 at Atikokan (A1) and 2 at Thunder Bay (TB1, TB2). The COE increased from 1.57¢/kwh to 2.5¢/kwh a 59.25% increase.

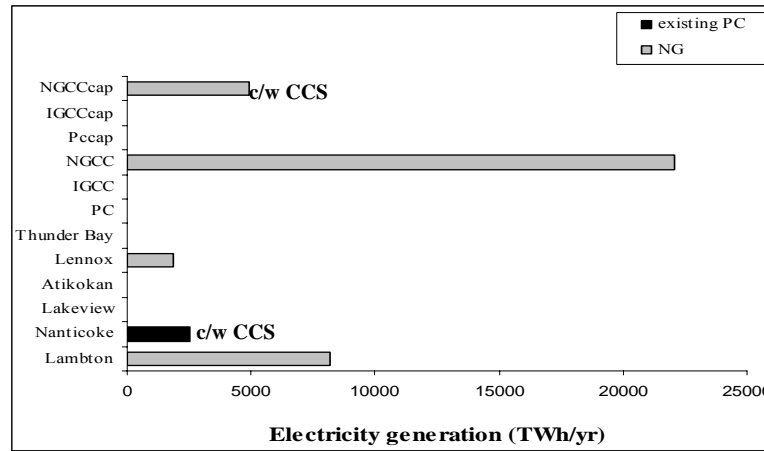

Figure 9 Optimal electricity generation for fossil fuel plants and 60% CO₂ reduction

Figure 10 shows a more complete summary of the increase in cost of electricity as a function of both the growth in demand and the CO₂ reduction target.

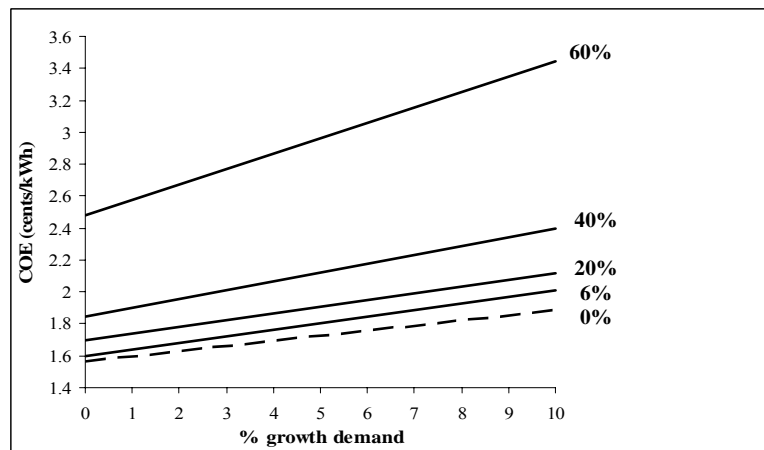

Figure 10 Effect of CO₂ reduction on the cost of electricity

The COE is linear with respect to demand. The COE is also linear from 0% to 40% CO₂ reduction, as shown in Figure 11.

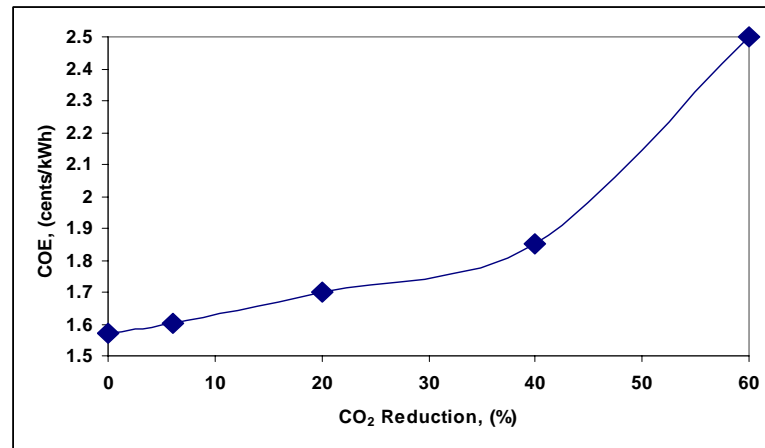

Figure 11 Cost of Electricity vs. % CO₂ reduction

However, once the CO₂ reduction is increased past 40% the COE increases dramatically. This is because at values between 0% and 40% the target can be met by either load balancing or fuel switching, however, past 40% the only alternatives involve significant structural changes to the fleet involving CCS and new generating stations.

The impact of 20% changes in natural gas, coal and retrofit costs on the optimal generation strategy for a 20% CO₂ emission reduction was considered. The sensitivity analysis showed that an increase in the fuel prices directly increases the COE. However, they did not have a significant effect on the optimal strategy to reduce CO₂ emissions, in other words Figure 8 remained unchanged. A similar trend was observed with the effect of the retrofit cost on the optimal strategy. This is not too surprising when one observes that the optimiser has already balanced the fleet of generating stations to minimise cost and reduce emissions by 3%; now it must make more costly decisions to reduce the CO₂ emissions by a further 17%.

2.3 Future Work

Our research in this aspect of carbon capture and storage (CCS) is continuing. We are now working on the so-called multi-period problem in which we will consider a time horizon of say 20 years for the implementation of CCS and new generating stations. A second area that has arisen from this work is that of uncertainty; as a result we have embarked on the development of a stochastic model of demand. Finally, dynamics of the operation of the electricity grid and a carbon capture process need to be investigated.

3.0 Conclusions

1. CO₂ capture from a single coal fired power plant results in de-rates of about 30%.
2. Reservoirs with capacity for up to 400 years of storage from a single 500 MW boiler or up to 50 years from the entire generating station have been located approximately 120 km from the Nanticoke Generating Station. The cost of storage is ~\$7 - \$14/tonne of CO₂.
3. An MILP model applied to OPG's generating stations indicates that fuel balancing and switching are effective options to reduce CO₂ emissions up to ~40% with a 21% increase in the COE. If CO₂ emissions reductions, greater than 40%, are required it is necessary to employ CCS. CCS is expensive and requires large amounts of parasitic energy. For example, a 60% reduction results in a 59% increase in the COE.

4. A sensitivity analysis shows that similar fuel switching patterns are observed when increasing the natural gas price and retrofit cost.

Acknowledgements

The authors wish to thank Ontario Power Generation for their financial and technical support towards this opportunity to contribute to the academic study of CO₂ capture. The Government of Canada through the Natural Sciences and Engineering Research Council also contributed to the successful completion of this research.

References

- [1] Singh, D., E. Croiset, P.L. Douglas and M.A. Douglas, 2003, "Techno-Economic Study of CO₂ Capture From an Existing Coal-Fired Power Plant: MEA Scrubbing vs. O₂/CO₂ Recycle Combustion", *Energy Conversion & Management*, 44, 3073 - 3091
- [2] Desideri U., Paolucci, A. (1999). Performance Modelling of a Carbon Dioxide Removal System For Power Plants, *Energy Conversion & Management*, 40, 1899-1915.
- [3] Marion, J. Nsakala, N.Y., Guha, M., Plasynski, S., Johnson, H., Gupta, J.C., 2001, "Engineering Feasibility of CO₂ Capture on Existing US Coal-Fired Power Plant", In 26th International Conference on Coal Utilization & Fuel System, Clearwater, Florida, March 2001
- [4] Won, K. W., J. R. Scherffius, and Peter Condorelli, 1999, "Improved Econamine FG Process and Economic Evaluation", Fluor Daniel Inc.
- [5] Alie, C., L. Backham, E. Croiset, P.L. Douglas and M.A. Douglas, 2005, "Simulation of CO₂ Capture Using MEA Scrubbing: a Flowsheet Decomposition Method", *Energy Conversion & Management*, 46, 475-487
- [6] Alie, C., "CO₂ Capture With MEA: Integrating the Absorption Process and Steam Cycle of an Existing Coal-Fired Power Plant", 2004, MASC Thesis, Dept. of Chem. Eng., U of W, Waterloo, Ontario, CANADA
- [7] Aspen Technology, Inc., Cambridge, MA, USA. *Aspen Plus V-11.1 User Guide*, 2001
- [8] Shafeen, A., E. Croiset, P.L. Douglas and I. Chatzis, 2004, "CO₂ Sequestration in Ontario, Canada, Part II: Cost Estimation", *Energy Conversion & Management*, 45, 3207-3217
- [9] Shafeen, A., E. Croiset, P.L. Douglas and I. Chatzis, 2004, "CO₂ Sequestration in Ontario, Canada, Part I: Storage Evaluation of Potential Reservoirs", *Energy Conversion & Management*, 45, 2645-2659
- [10] Hitchon B, Aquifer Disposal of Carbon Dioxide-Hydrodynamic and Mineral Trapping-Proof of Concept: *Report of a three-year study by the Alberta research council*, Geoscience Publishing Ltd., 1996, Alberta, Canada.
- [11] Freund P, and Davidson J, 'General overview of cost', IEA Greenhouse Gas R&D Programme, *IPCC Workshop on Carbon Capture and Storage*, Regina, Canada, 2002.
- [12] Allison G, Nguyen V, The economics of CO₂ sequestration in Australia, *5th International Conference on Greenhouse Gas Control [GHGT-5]*, Cairns, Australia, 2000.
- [13] Hendriks CA and Block K, Underground storage of carbon dioxide, *Energy Conversion & Management*, 1995; 36(6-9): 539-542.
- [14] Ontario Power Generation, Ontario, Canada, 2002, Personal Communication
- [15] Hashim, H., P.L. Douglas, A. Elkamel and E. Croiset, 2005, "An Optimization Model for Energy Planning with CO₂ Emission Considerations", *Industrial & Engineering Chemistry Research*, 44, 879-890
- [16] Hashim, H., "An Optimal Fleet-wide CO₂ Mitigation Strategy for a Network of Power Plants", 2006, PhD Thesis, Dept. of Chem. Eng., U of W, Waterloo, Ontario, CANADA
- [17] Brooke A., Kendrick D., and Meeraus A. *GAMS: A User's Guide*. The Scientific Press, South San Francisco, CA, 1998.
- [18] Natural Resources Canada, Analysis and modelling division, <http://climatechange.nrcan.gc.ca/english/Home.asp?x=1>