

# Passenger Car Handling Model Validation Using LMS-DADS

**Pakharuddin Mohd. Samin,  
Tang Siew Eng & Khisbullah Hudha**  
University Teknologi Malaysia

## ABSTRACT

This paper presents the modeling and validation of a multibody passenger car model to evaluate the handling performance. LMS-DADS generated the multibody passenger car model with PROTON WAJA as the benchmark. Several transient handling performance test had been performed, included double-lane change test, J-turn test and Slalom test at constant speed. An open-loop study is performed to evaluate the handling performance which the model responded to the steering input given. Comparisons of the experiment result and model simulation with steering wheel imposed motion are made. Some of the quantities illustrated include steering wheel input, lateral acceleration and yaw rate. Predictions of the model's responses agree with the actual measured vehicle's responses within some specified level of accuracy using qualitative validation.

## INTRODUCTION

Vehicle dynamics simulation using multibody model has been very useful in reducing time and cost in the development stage. Among several vehicle dynamic simulation software, LMS-DADS is a computer simulation tool used to simulate the vehicle dynamics behavior and performances, either it is a single or multibody system. By inserting the model data, the mathematical equations will be automatically formed internally at the DADS Model that can be solved and results can be studied by constructing DADS Graph module or visualize the system behavior through animation in DADS Model. Through the simulation, engineer may understand the dynamic behavior of the vehicle in different operating conditions

In this paper, a simplified DADS passenger car model had been generated to validate the model in handling maneuvers. As the DADS is multibody simulation software, the model body can be divided into few subsystems. There are six subsystems in the multibody model included front suspension, rear suspension, front wheel and tire, rear wheel and tire, steering system and the chassis body.

Several transient handling test is performed for the handling simulation with the created DADS Waja. In order to validate the multibody model, experiment measurement were carried out with the steering imposed motion and the results were compared to simulation results, with the same motion.

## DESCRIPTION OF DADS SIMULATION

LMS-DADS (Language of Multibody System-Dynamic Analysis and Design System) is a computer simulation tool that used to predict the behavior of single or multibody mechanical systems. By inserting the model data, the mathematical equations will be automatically formed internally at the DADS Model that can be solved and results can be studied by constructing DADS Graph module or visualize the system behavior through animation in DADS Model.

The alternative to using DADS would be to write equations for the system manually. One would need to solve these equations in 'closed form' or write a computer program to solve them numerically. Even for simple two-body systems this can be a tedious, time-consuming process but in DADS, it will automatically sets up and solves the equations for the most complex mechanical systems. The greater the number of equations and variables form with the larger the system. DADS takes advantage of the most advanced 'state-of-the-art' solution algorithms where these algorithms have been tested and validated through many man-years of development.

In DADS, problems that associated with larger nonlinear displacement of parts connected joints and force element can be solved. Using the DADS simulation, it can be:

- i. Study an existing design to understand design errors and problems
- ii. Predict design behavior before design is fabricated.
- iii. Perform parametric trade-off studies to explore several design alternatives.
- iv. Predict system behavior where testing is either too dangerous,
- v. Expensive or, impossible.

The design capability for the analysis that can be running using the DADS included:

- i. Static analysis
- ii. Large displacement transient analysis
- iii. Small displacement around a static solution and at any solution point in time as included :
  1. Vibrational analysis
  2. Modal analysis, modal sensitivity, and modal optimization.

## MULTIBODY MODEL OF THE PASSENGER CAR

For multibody simulation software, the model body can be divided into few parts. There are six subsystems in the multibody model of the passenger car. These included front suspension, rear suspension, front wheel and tire, rear wheel and tire, steering system and the chassis body. The parts are attached to the main frame while the main frame is known as 'unit body' where it combines the body frame and front metal sheet to become one structure. Figure 1 shows the model in DADS.

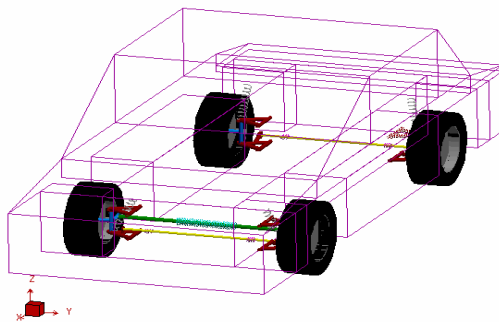

**Figure 1: The Multibody Model in LMS-DADS**

The front suspension consists of five parts such as, lower arm, spindle, anti-roll bar, spring and absorber. The spring and absorber are connected to the body at the top end of the suspension. There were modeled with linear coefficient. The upper and lower arms are connected to the main frame. The spindle is used to join the lower arm, upper arm, spring and damper to the wheel thus the wheel displacement will be transfer to the vehicle body through the spindle. The steering bar is also connected on the both spindles to transfer the steer action to the wheel through spindle. The anti-roll bar is connected on the both side lower arm. This will give an effect to reduce the body roll when the model is negotiates a cornering by increase the stiffness of the suspension system without effecting the motion of the suspension system. Figure 2 showing the front suspension system of the model.



**Figure 2: 3D DADS Model of the Front Axle**

The real suspension consists of upper arm, lower arm, anti-roll bar, spring and absorber. As in front suspension, the elements are interconnected with each other to have the reaction from the force acting on the structure.

In rear suspension, the spring and absorber is connected to the vehicle body from the spindle. Any direct movement of the wheels will be also transfer to the vehicle body. The anti-roll bar is also increase the stiffness of the rear axle to reduce the body roll. The roll center is defined from the inclination angle of the shock and absorber element where the rear roll center will be higher than the front as the geometry of the rear axle is shown at Figure 3.



**Figure 3: 3D DADS Model of the Rear Axle**

As the simulation is perform by adding the input of steer displacement, the steering linkage is been modeled as shown in Figure 4. In the model, only the tie rod reacted as the steering bar was attaches to the modal that represented the steering system. The linear translation of the steer bar is transmits to the rotational movement at the wheel through the spindle. The simplification is made in order to cut down the processing time where the torque needed to apply at the steering wheel is negligible as it consumes longer time to propel a body.

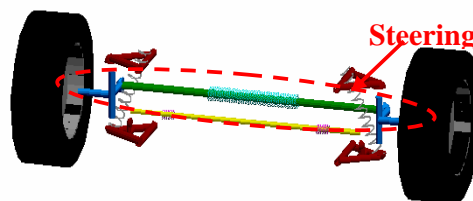

**Figure 4: Steering Bar in DADS Model**

When using the DADS simulation, joints and constraint are the elements that create a mathematical relationship controlling the position of a body or a pair of bodies. Joints elements used to model various types of connections between rigid and flexible bodies. These elements remove a varying number of degrees of freedom from the mechanism, based upon the type of joint.

Constraint elements are available to model kinematics relationships between rigid or flexible bodies. These elements can be used for any type of analysis. Constraint elements govern the way in which bodies move relative to one another or the "world"

or global triad. In all cases, one or two body names and associated triad names are required. Other relevant data is also collected to make a complete element description.

Force elements are important in order to running the static, dynamic, and the inverse dynamic analysis. It does not affect the number of degrees of freedom in a model so it will not affect the kinematics analysis. The forces are defined by gravity, damper, spring, bushing, tires or control output elements that contribute to the external force.

For a 3D multibody vehicle simulation, the body created will generalize seven coordinates. In order to allow certain motion on the body, the joints and the constraints will be added to create the mathematical relationship between a pair of bodies or dictate the location of one body. This giving certain degree of freedom to the body and allow the motion needed.

Types of joints that were used most in the model were Revolute Joints, Spherical Joint, Cylindrical Joint and Bracket Joint. Figure 5 showing the different type of joints used in the front axle model. The revolute joint permits only a single rotational degree of freedom between two bodies. The joint is model by locating two triads on two bodies. As in the front axle, the revolute joint permits the rotational degree of freedom for the wheels and allows the spindle to turn with the translational movement of the steer bar.

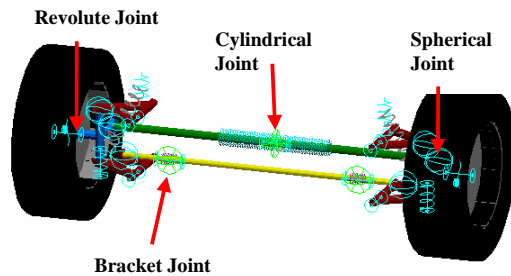

**Figure 5: Symbols of Joints Used in DADS Model**

The cylindrical joint allows the body to move in a translational movement and a rotational movement at the same axis between the two bodies. In the model, the cylindrical model allows the steering bar to move in a relative translational movement with the slider and free rotation at the same axis. The spherical joint allows three relative rotational degrees of freedom between two bodies where two triad origins are coincident. A bracket joint used in the model was attached to the chassis body to prevent any relative motion between the two bodies as it fixed the position of two separate rigid or flexible bodies together.

A relative translational constraint was added to the model between steering bar and the slider in order to permit a given translational movement to the steering bar to act as the steering input. By define the translational movement by a curve driver, where the displacement of the steering bar is given based on time input, the steering bar become steer able and steer the wheel to turn.

The forces the placed on the vehicle model included 3D Tire Element which it defines the tire and Translational Spring Damper Actuator (TSDA) which define the spring and shock absorber of the model. The tire element was built using the generic tire element. The tire forces include lateral force, vertical force and also the longitudinal force. By define the tire stiffness and also the cornering stiffness, lateral stiffness and lateral damping; the tire element will generalized the mathematic relationship that showing the tire reaction by the given steering input.

For the Translational spring damper and actuator, it is a two-body force element that applies between a pair of point fixed to two different bodies. The force define by the TSDA is a function of the distance and velocity between the two attached triad and origin.

When developing the model, there are several simplifications were introduces because of the limited experiment information and limitation of the software where:

- i The system was assumed frictionless
- ii. When running the model, the model is assumed will not affect by the aerodynamic force.
- iii. The ball joint was representing by a spherical joint.

In order to running the handling analysis, there motion need to be added to the model. In DADS, method that can be used to apply the motion is through applying the Initial Condition command. This method is much more convenient and effective by applying the speed value directly to the model.

**HANDLING MODEL VALIDATION**

An open-loop maneuver has been performed using the experimental steering wheel angle imposed at the steer wheel of the model to evaluate the vehicle response and validate the model. Several handling test had been performed included Double Lane Change test, J-Turn test and Slalom Tests. Before running the simulation, the ground test study of a full scale passenger car was also performed to obtain the actual vehicle response.

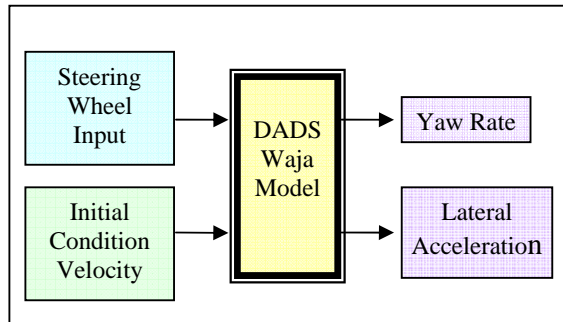
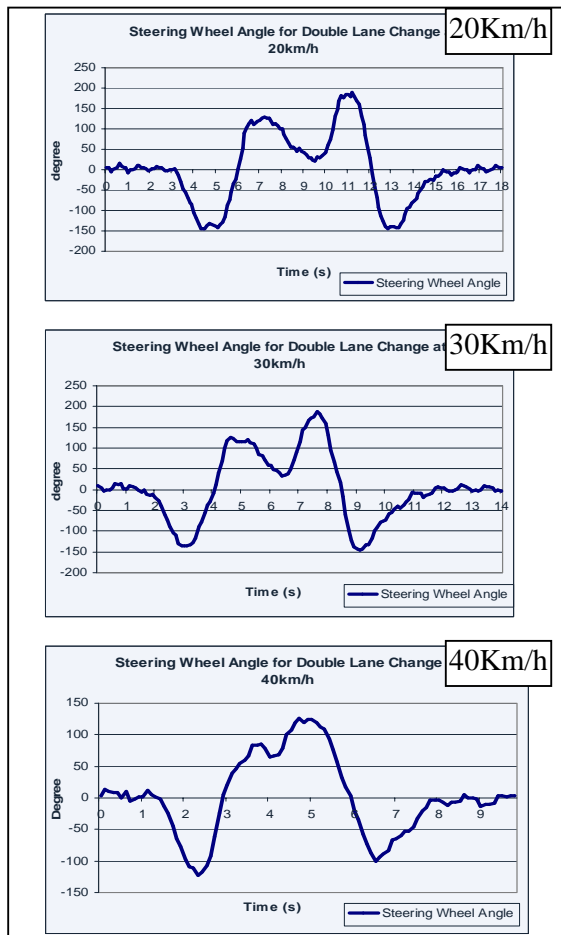

**Figure 6: Steering Wheel Imposed Motion for Simulation Study**

**DOUBLE-LANE CHANGE TEST**

Double-lane Change is one of the handling tests to evaluate the road holding of the vehicle. This handling test had been identified by the ISO and it can be considered as the representative of some crash avoidance.

Figure 7 showing the steering wheel angle as the input for the double-lane change tests which obtained through experiment study for 20km/h, 30km/h and 40km/h. From the input, parameter obtained for the lateral acceleration and yaw rate response will be use to validate the model.



**Figure 7: Steering Wheel Angle for Double Lane Change at Different Speed**

Figure 8 showing the lateral acceleration results obtained for double-lane change test for both simulation and experiment study for different speeds. Results showing that the simulation results obtained for all the tested speeds are very close to the experimental results. The simulation result is best correlate with the experiment result at 20km/h. The maximum lateral acceleration obtained from simulation is higher than the experimental result but still in acceptance range of differentiation.

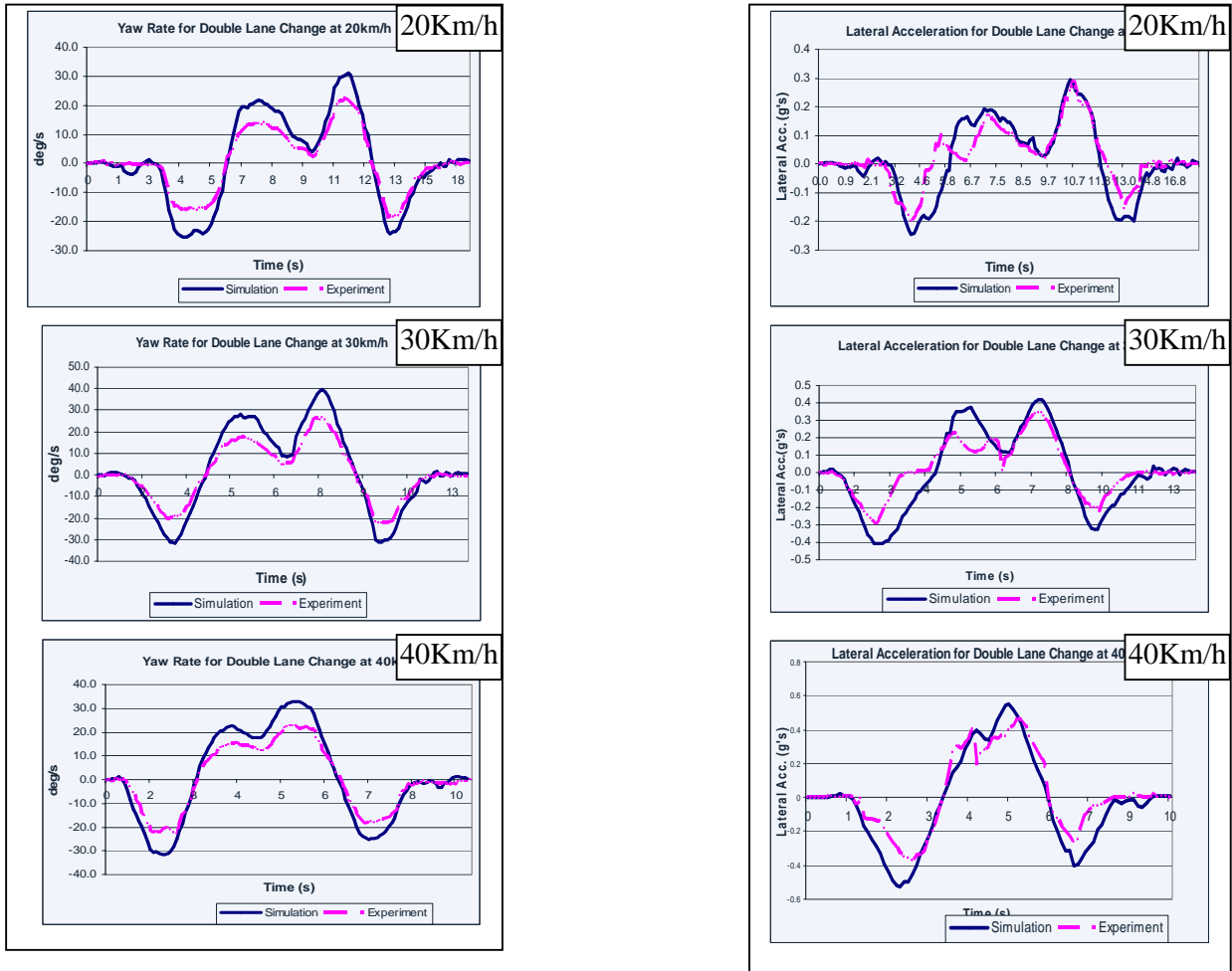

**Figure 8: Lateral Acceleration for Double Lane Change**

Figure 9 showing the yaw rate responses obtained. The peak of the simulation result obtained for all the speed is higher than the experiment. This shows that the real vehicle has more damping in the yaw mode than the simulation model which might due to weight and the structure that the model had been simplified. The model are shown a good response to the yaw mode seen the results obtained is closely to the experiment at all the tested speed.

**Figure 9: Yaw Rate for Double Lane Change**

J-TURN TEST

J-turn test used to be predicted the lateral direction attributes of the vehicle as it transitions from straight line running to a steady state cornering condition. With the same road profile for the J-turn test, Figure 10 showing the steering wheel angle applied with speed from 20km/h to 40km/h.



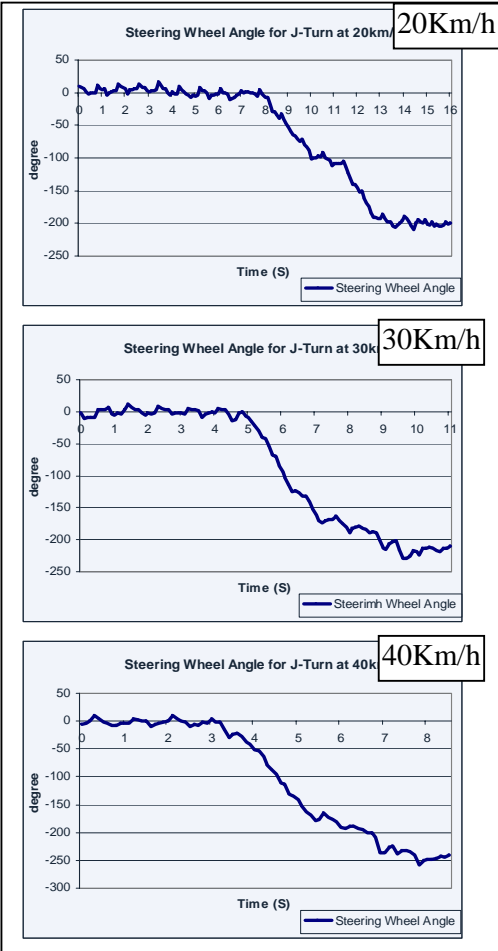

**Figure 10: Steering Wheel Angle for J-Turn Test**

Through the input given, the yaw rate responses for the J-turn tests for both method at all tested speed are shown in Figure 11. Result shown that the simulation result had performed a reliable study in yaw rate mode compared to the experiment result at all tested speed but with a higher yaw rate response. The differentiation of the yaw rate is similar in either 40km/h to 20km/h shown that the correlation between the simulation result and experiment result are not effected by the vehicle speed. The results only deviated during the vehicle cornering and once again showing that the real vehicle have more damping in the yaw mode compare to model.

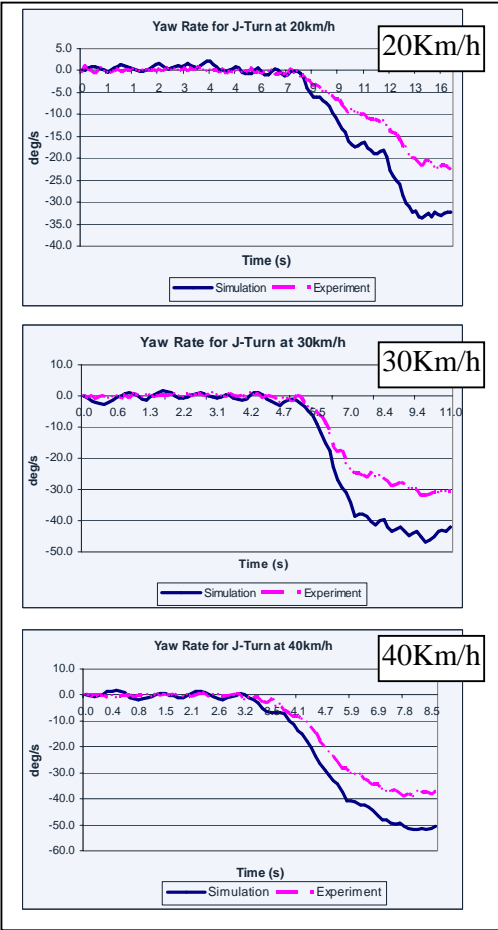

**Figure 11: Yaw Rate for J-Turn Test**

Figure 12 showing the lateral acceleration results in the time domain for J-turn test. At all tested forward speed, the simulation result generally had a higher maximum lateral acceleration response but it indeed has a good correlation with the real vehicle response.

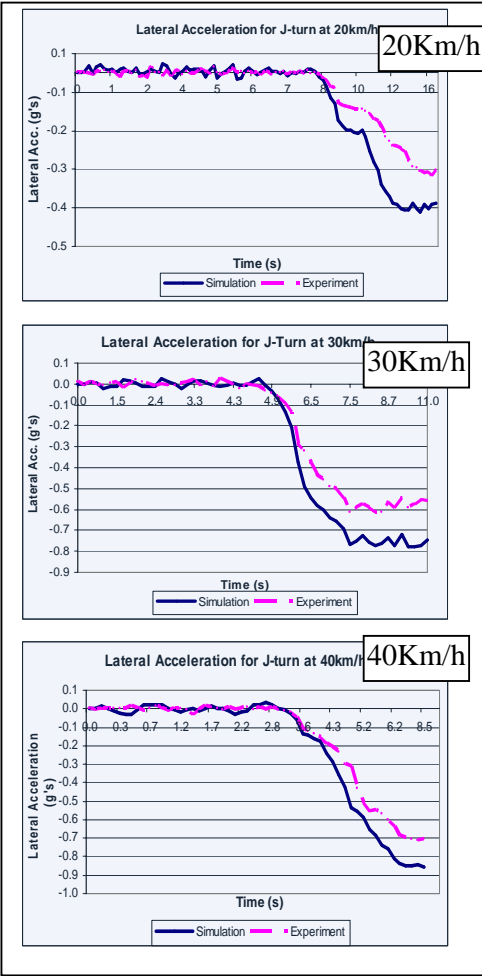
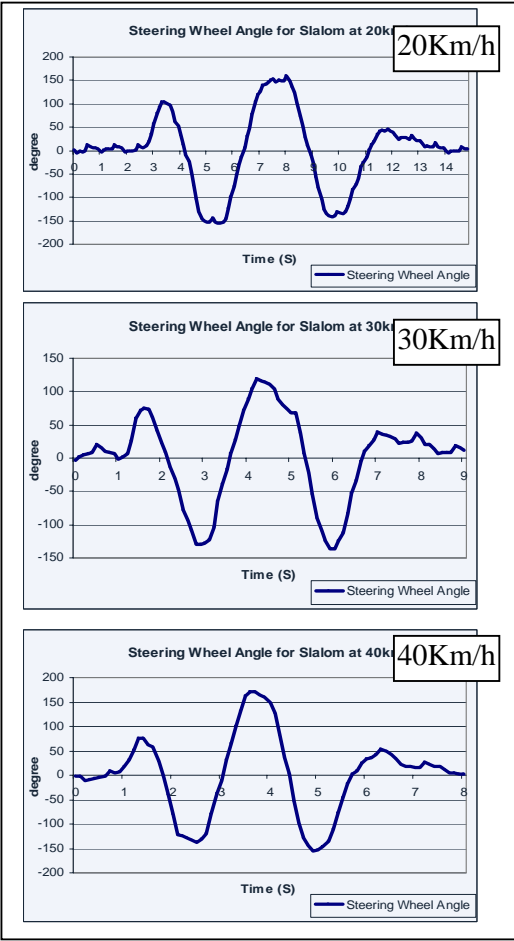

**Figure 12: Lateral Acceleration for J-Turn Test**

**SLALOM TEST**

Slalom test used to predict the vehicle’s reaction to transient steering wheel inputs and allow determining the response of the driving state parameter for yaw velocity and lateral acceleration.

Figure 13 showing the steering wheel input for the slalom test. The input shown is just like the sine wave curve. The steering wheel input is nearly the same for the tested speeds.



**Figure 13: Steering Wheel Angle for Slalom**

Figure 14 was the lateral acceleration response generated for the slalom test by both simulation and experiment in 20, 30 and 40km/h. The simulation results are very close the experiment result for all tested speed and following the curve trend as experiment result. The peak lateral acceleration obtained from simulation is higher than the experimental in all tested speed.

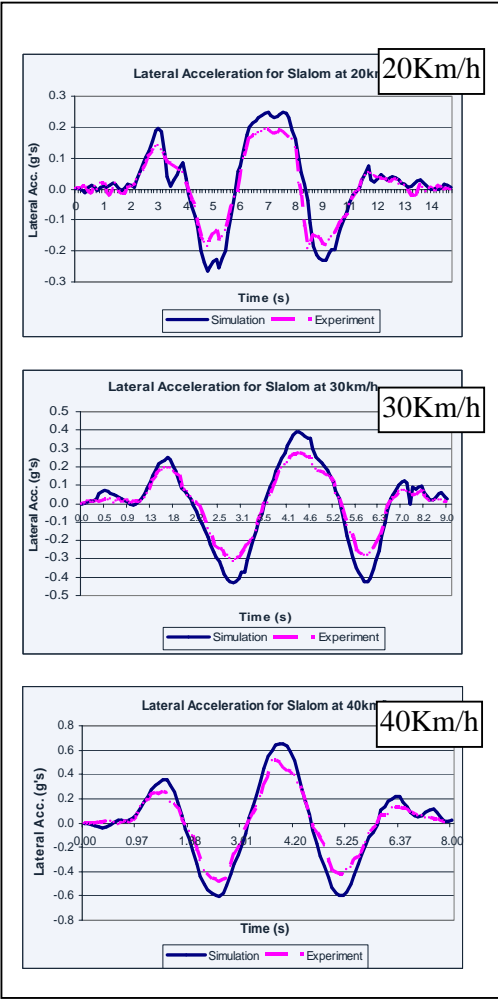

**Figure 14: Lateral Acceleration for Slalom**

The yaw rate response is obtained for both methods as shown in Figure 15. The real vehicle had more damping in the yaw mode than the simulation model for all tested speed where the model had a higher yaw rate than the real vehicle. The figure shown that the results obtained from the simulation are indeed had a good correlation with the experimental results.

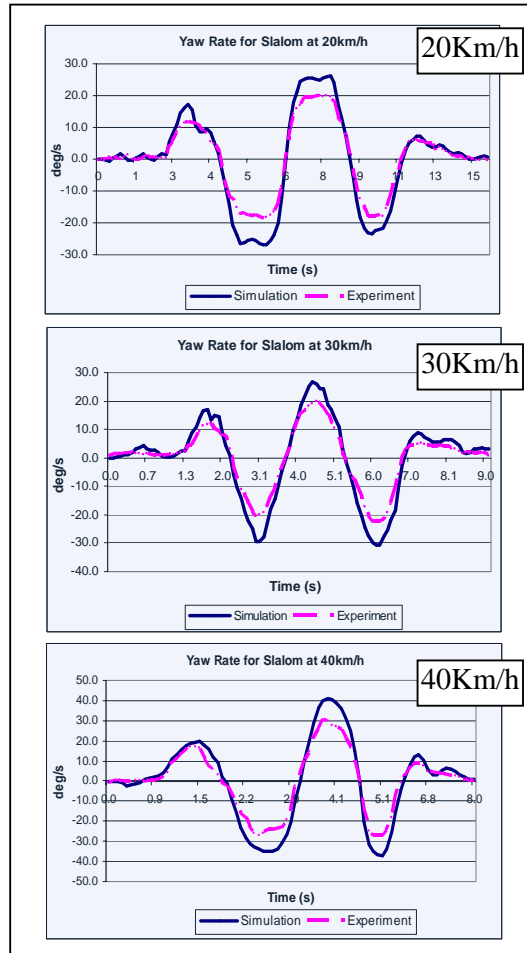

Figure 15: Yaw Rate for Slalom Test at Different Speed

## CONCLUSION

Model validation conducted in this project had been supported by different handling maneuvers situation. The validation had covered the qualitative method where the accuracy of the simulation predictions is compared visually with the experiment results. The passenger car model used had been validated for the Double Lane Change test, J-turn test and Slalom test as the simulation result were very close to the experiment result.

A simulation may be deemed valid for predicting the particular physical system behavior for which it was designed to model. The strengths and the weaknesses of the individual simulations can be identified and compared to choose the most appropriate simulation. Apart from that, the simulation validation also became a valuable method for modifying and enhancing a simulation. Areas of simulation disagreement with experiment results can be recognized through this handling measurement. Possible vehicle parameter specification errors or experimental data offset as well as calibration errors may become apparent during the validation process and the effort for model modification can be performed to obtain a more reliable measurement.

## REFERENCES

1. R.W Ray, P.D Gibson, "Vehicle Handling: Data Acquisition and Analysis Methods." I MEch Conference Publication 1983-5 Paper No. C126/83.
2. G.J Heydinger, W.R.Garrott, J.P.Chrstos, D.A.Guenther, "A Methodology for Validating Vehicle Dynamics Simulations." SAE Technical Paper No. 900128.
3. J.R Ellis (1994) "Vehicle Handling Dynamics." United Kingdom: Mechanical Engineering Publications Limited.

4. S.A Lukowski, L.Medeksza, "Vehicle Cornering Behavior Analysis Using A General Purpose Simulation Methodology." I MEch 1992 Paper No.C389/381.
5. P.Marcelo, R.H. Cunha, A.C Neto, "Bus Handling Validation and Analysis Using ADAMS/Car."
6. T.D.Gilliepie (1992) "Fundamentals of Vehicle Dynamics." United States of America, Society of Automotive Engineers, Inc.
7. S.L Chiang, D.S Starr, "Using Computer Simulation to Evaluate and Improve Vehicle Handling." SAE Technical Paper Series Paper No. 780009.
8. S. SANO. "Evaluation of Motor Vehicle Handling." Wako-shi, Honda R & D Co. Ltd.