

MODELING AND CONTROL OF ELECTROHYDRAULIC ROBOT
MANIPULATOR

NORSINNIRA ZAINUL AZLAN

A project report submitted in partial fulfilment of the
requirements for an award of the degree of
Master of Engineering (Electrical-Mechatronics and Automatic Control)

Faculty of Electrical Engineering
Universiti Teknologi Malaysia

MAY, 2006

PUBLICATION

The following papers, based on the work described in this thesis, have been submitted to conferences:

1. Norsinnira Zainul Azlan and Johari Halim Shah Osman. Modeling And Proportional Integral Sliding Mode Control Of Hydraulic Manipulators. *4th Student Conference on Research Development (SCOReD)*. 2006. Kuala Lumpur, Malaysia. (Accepted for Oral Presentation and Publication).
2. Norsinnira Zainul Azlan, Johari Halim Shah Osman and Mohd Noh Ahmad. Proportional Integral Sliding Mode Control Of Hydraulic Robot Manipulators. *First International Conference on Industrial Systems (ICISS)*. 2006. Sri Lanka. (Under Review).
3. Norsinnira Zainul Azlan, Johari Halim Shah Osman and Mohd Noh Ahmad. Sliding Mode Control Of A Hydraulically Actuated Robot Manipulator Using Proportional Integral Switching Surface. *First International Conference on Man-Machine Systems (ICoMMs)*. 2006. Langkawi, Malaysia. (Under Review).

ABSTRACT

This thesis is concerned with the mathematical modeling and the position tracking control of hydraulic manipulators. Hydraulically actuated manipulators are widely used in a number of applications including manufacturing and assembly since they provide high power to weight ratio and short response time. To increase the performance of the manipulators, it is essential to control the system well. However, in spite of their advantages, hydraulic manipulators are more complicated in nature due to the nonlinear characteristic of the mechanical linkage and the hydraulic actuator dynamics, parameter variations, payload uncertainties and strong couplings among various joints. The control problem of this system consists of obtaining the physical dynamic model and specifying the corresponding control strategy so that it tracks a predefined desired trajectory as closely as possible at all times. In this thesis, an integrated mathematical dynamic model of a hydraulically driven revolute robot manipulator in state variable form is presented. The integrated model comprises of the dynamic model of the manipulator mechanical links as well as the actuators dynamics. The formulation represents a more realistic dynamic model, thus provides a better and much more suitable model for the purpose of dynamic analysis and controller synthesis. Proportional Integral Sliding Mode Control (PISMC) strategy is adopted to provide the position tracking control for the system. The technique takes the advantages of zero steady error due to the integral term and robustness offered by the Sliding Mode Control (SMC). It is shown mathematically that the proposed controller does not only make the system insensitive to parameter variations, uncertainties and couplings; but also guarantees stability in the large based on Lyapunov theory. The performance of the proposed approach is evaluated and compared with the existing Independent Joint Linear Control (IJC) technique through computer simulation. A 3 DOF revolute robot is used in this study. The results prove that the controller has successfully provided the necessary position tracking control for the hydraulic robot manipulator system.

ABSTRAK

Tesis ini bertujuan untuk mengenengahkan model matematik dan teknik kawalan bagi robot berkuasa hidro. Robot berkuasa hidro digunakan dengan meluas dalam pelbagai aplikasi termasuklah di sektor pembuatan dan pemasangan memandangkan sistem ini mampu membekalkan nisbah kuasa kepada berat yang tinggi dan tindak balas yang cepat. Pengawalan yang baik adalah amat penting bagi meningkatkan mutu pencapaian robot ini. Walaubagaimanapun, di sebalik kelebihan yang ditawarkan, sistem ini adalah lebih rumit disebabkan sifat sambungan mekanikal dan motornya yang tidak linear, parameter yang berubah-ubah, ketidaktentuan beban dan kesan perangkai. Masalah kawalan ini terdiri daripada usaha mendapatkan model dinamik fizikalnya dan menentukan strategi kawalan yang sewajarnya supaya robot ini menjejaki sebuah laluan/ trajektori yang dikehendaki. Dalam tesis ini, sebuah pemodelan matematik untuk lengan robot yang dipandu oleh kuasa hidro dibentangkan. Ia mengandungi model dinamik komponen mekanikal robot dan juga motor berkuasa hidro. Formulasi ini menghasilkan sebuah model yang lebih realistik, seterusnya memberikan model yang lebih baik dan sesuai untuk tujuan penganalisan dinamik dan sintesis kawalan. Strategi kawalan ragam gelincir berkadaran kamiran (PISMC) diadaptasi untuk membekalkan kawalan penjejakan posisi untuk sistem ini. Teknik tersebut memanfaatkan kelebihan keadaan mantap sifar yang disebabkan komponen kamiran dan ciri ketegapan yang ditawarkan oleh komponen kawalan ragam gelincir berkadaran. Adalah ditunjukkan melalui kaedah matematik bahawa pendekatan yang dicadangkan ini bukan sahaja mampu mengatasi ciri-ciri rumit yang terdapat dalam robot berkuasa hidro, bahkan stabil berdasarkan teori Lyapunov. Pencapaian kaedah ini dinilai dan dibandingkan dengan teknik kawalan penghubung berdikari linear (IJC) melalui simulasi komputer. Sebuah robot yang mempunyai tiga darjah kebebasan digunakan dalam kajian ini. Keputusan membuktikan bahawa, strategi kawalan ini berjaya dalam membekalkan kawalan laluan/ trajektori yang diperlukan untuk sistem lengan robot berkuasa hidro.

CONTENTS

CHAPTER	TITLE	PAGE
	DECLARATION	ii
	DEDICATION	iii
	ACKNOWLEDGEMENT	iv
	PUBLICATION	v
	ABSTRACT	vi
	ABSTRAK	vii
	CONTENTS	viii
	LIST OF TABLES	xii
	LIST OF FIGURES	xiii
	LIST OF SYMBOLS	xvi
	LIST OF ABBREVIATIONS	xxii
1	INTRODUCTION	1
	1.1 Robot Manipulator System	1
	1.2 Electrohydraulic Robot Manipulator	2
	1.3 Manipulator Linkage Dynamic Model	5
	1.4 Electrohydraulic Manipulator Control Strategies	8
	1.5 Objective	11
	1.6 Scope of Project	12
	1.7 Research Methodology	13
	1.8 Structure and Layout of Thesis	14

2	MATHEMATICAL MODELING OF ELECTROHYDRAULIC ROBOT MANIPULATOR	16
2.1	Introduction	16
2.2	Dynamic Equation of Robot Manipulator Mechanical Linkage	17
2.3	Dynamic Equation and State Space Representation of Electrohydraulic Actuator	18
2.4	Integrated Dynamic Model of N DOF Revolute Electrohydraulic Robot Manipulator	25
2.4.1	Dynamic Equation for the N DOF Mechanical Linkage	25
2.4.2	Derivative of the N DOF Mechanical Link Torque	26
2.4.3	The Electrohydraulic Motors Dynamics	27
2.4.4	Integrated Model of the N DOF Electrohydraulic Robot Manipulator	28
2.5	Integrated Dynamic Model for a Three DOF Revolute Electrohydraulic Robot Manipulator	32
2.5.1	Dynamic Equation of the Three DOF Mechanical Linkage	34
2.5.2	Derivative of the Three DOF Mechanical Link Torque	37
2.5.3	The Electrohydraulic Motors Dynamics for the Three DOF Robot Manipulator	38
2.5.4	Integrated Model of the Three DOF Electrohydraulic Robot Manipulator	41
2.6	Summary	46

3	PROPORTIONAL INTEGRAL SLIDING MODE CONTROLLER DESIGN	47
3.1	Introduction	47
3.2	Decomposition into an Uncertain System	49
3.3	Problem Formulation	52
3.4	System Dynamics during Sliding Mode	55
3.5	Sliding Mode Tracking Controller Design	56
3.6	Summary	61
4	SIMULATION AND RESULTS	63
4.1	Introduction	63
4.2	Trajectory Generation	64
4.3	Simulation Using Independent Joint Linear Control (IJC)	66
4.4	Simulation Using Proportional Integral Sliding Mode Controller	69
4.4.1	Controller Parameters Selection	71
4.4.2	Tuning Algorithm	72
4.4.3	Numerical Computation and Selection of Controller Parameters	73
4.4.4	Effect of Load Variation	82
4.4.5	Effect of the Controller Parameter, γ_1, γ_2 and γ_3	86
4.4.6	Control Input Chattering Suppression	91
4.4.7	Effect of Proportional Integral Sliding Surface Constant, C	96
4.4.8	Effect of Sampling Time	98
4.5	Summary	101

5	CONCLUSION & FUTURE WORKS	102
5.1	Conclusion	102
5.2	Suggestion For Future Work	103
	REFERENCES	105

LIST OF TABLES

TABLE NUMBER	TITLE	PAGE
2.1	Range of Operation of the Mechanical Linkage	32
2.2	Parameters of the Mechanical Linkage	33
2.3	Parameters of the Hydraulic Actuator	33
3.1	Maximum, Minimum, Nominal and Uncertainty Values of $A_M(X, \xi, t)$ and $B(X, \xi, t)$	51

LIST OF FIGURES

FIGURE NUMBER	TITLE	PAGE
1.1	Schematic of a Hydraulic System and its Components	3
1.2	Schematic of a Spool Valve in Neutral Position	4
2.1	Physical Model of an Electrohydraulic Servo Control	19
2.2	Gear Train Connecting the Motor and the Load	22
2.3	Three DOF Hydraulically Driven Robot Manipulator	34
4.1	Desired Joint 1 Position Profile	64
4.2	Desired Joint 2 Position Profile	65
4.3	Desired Joint 3 Position Profile	65
4.4	Joint 1 Tracking Response using IJC Control	68
4.5	Joint 2 Tracking Response using IJC Control	68
4.6	Joint 3 Tracking Response using IJC Control	69
4.7	Simulation Flow Chart	70
4.8	Joint 1 Tracking Response Handling No Load	76
4.9	Joint 2 Tracking Response Handling No Load	77
4.10	Joint 3 Tracking Response Handling No Load	77
4.11	Joint 1 Tracking Error Handling No Load Using PISMC and IJC	78
4.12	Joint 2 Tracking Error Handling No Load Using PISMC and IJC	78
4.13	Joint 3 Tracking Error Handling No Load Using PISMC and IJC	79
4.14	Joint 1 Control Input Handling No Load	79
4.15	Joint 2 Control Input Handling No Load	80

4.16	Joint 3 Control Input Handling No Load	80
4.17	Joint 1 Sliding Surface Handling No Load	81
4.18	Joint 2 Sliding Surface Handling No Load	81
4.19	Joint 3 Sliding Surface Handling No Load	82
4.20	Joint 1 Tracking Response with Mass Variation	83
4.21	Joint 2 Tracking Response with Mass Variation	83
4.22	Joint 3 Tracking Response with Mass Variation	84
4.23	Joint 1 Tracking Error with Mass Variation	84
4.24	Joint 2 Tracking Error with Mass Variation	85
4.25	Joint 3 Tracking Error with Mass Variation	85
4.26	Joint 1 Tracking Response with Unsatisfied Controller Parameters	87
4.27	Joint 2 Tracking Response with Unsatisfied Controller Parameters	87
4.28	Joint 3 Tracking Response with Unsatisfied Controller Parameters	88
4.29	Joint 1 Control Input with Unsatisfied Controller Parameters	88
4.30	Joint 2 Control Input with Unsatisfied Controller Parameters	89
4.31	Joint 3 Control Input with Unsatisfied Controller Parameters	89
4.32	Joint 1 Sliding Surface with Unsatisfied Controller Parameters	90
4.33	Joint 2 Sliding Surface with Unsatisfied Controller Parameters	90
4.34	Joint 3 Sliding Surface with Unsatisfied Controller Parameters	91
4.35	Joint 1, Joint 2 and Joint 3 Control Input Using Discontinuous Function $SGN(\sigma(t))$	93
4.36	Joint 1, Joint 2 and Joint 3 Control Input Using Continuous Function Set 1	93
4.37	Joint 1, Joint 2 and Joint 3 Control Input Using Continuous Function Set 2	94

4.38	Joint 1 Tracking Error Using Discontinuous and Continuous Function Sets	94
4.39	Joint 2 Tracking Error Using Discontinuous and Continuous Function Sets	95
4.40	Joint 3 Tracking Error Using Discontinuous and Continuous Function Sets	95
4.41	Joint 1 Tracking Response with Different Sliding Surfaces	97
4.42	Joint 2 Tracking Response with Different Sliding Surfaces	97
4.43	Joint 3 Tracking Response with Different Sliding Surfaces	98
4.44	Joint 1 Tracking Response with Different Sampling Time	99
4.45	Joint 2 Tracking Response with Different Sampling Time	100
4.46	Joint 3 Tracking Response with Different Sampling Time	100

LIST OF SYMBOLS

<u>SYMBOL</u>	<u>DESCRIPTION</u>
1. UPPERCASE	
A	$3N \times 3N$ system matrix for the augmented dynamic equation of the hydraulic actuator
A_i	3×3 system matrix for the i th hydraulic actuator
$A(*,*,*)$	$3N \times 3N$ system matrix for the integrated hydraulic robot manipulator without incooperating the nonlinear matrix
$A_N(*,*,*)$	$3N \times 3N$ system matrix for the integrated hydraulic robot manipulator incooperating the nonlinear matrix
\bar{A}	nominal value of the system matrix $A_N(*,*,*)$
ΔA	uncertainty value of the system matrix $A_N(*,*,*)$
A_{NMAX}	maximum value of the system matrix $A_N(*,*,*)$
A_{NMIN}	minimum value of the system matrix $A_N(*,*,*)$
B	$3N \times N$ input matrix for the augmented dynamic equation of the hydraulic actuator
B_i	3×1 input matrix for the i th hydraulic actuator
$B(*,*,*)$	$3N \times N$ input matrix for the integrated hydraulic robot manipulator
B_{MAX}	maximum value of the input matrix $B(*,*)$
B_{MIN}	minimum value of the input matrix $B(*,*)$

ΔB	uncertainty value of the input matrix $B(*,*)$
\bar{B}	nominal value of the input matrix $B(*,*)$
B_m	viscous damping coefficient of the hydraulic actuator
C	constant matrix of the PI sliding surface
C_i	$N \times 3N$ i th sliding surface matrix
C_d	discharge coefficient of the hydraulic actuator
C_1	total leakage coefficient of the motor of the hydraulic actuator
$\tilde{C}(*,*,*)$	$N \times N$ coefficient matrix related to the acceleration vector in the derivative of the manipulator link dynamic equation
\tilde{C}_{ij}	ij th element of the matrix $\tilde{C}(*,*,*)$
D_m	volumetric displacement of the hydraulic actuator
$D(*,*,*)$	$N \times 1$ vector of coriolis and centrifugal forces
$\bar{D}(*,*)$	$N \times \sum_{i=1}^N i$ matrix related to $D(*,*,*)$ vector
\bar{D}_{ij}	ij th element of the matrix $\bar{D}(*,*)$
$\dot{\bar{D}}(*,*)$	derivative of the matrix $\bar{D}(*,*)$ with respect to time
$\hat{D}(*,*,*)$	$N \times N$ matrix related to the vector $D(*,*,*)$
$\tilde{D}(*,*,*)$	$N \times N$ coefficient matrix related to the velocity vector in the derivative of the manipulator link dynamic equation
\tilde{D}_{ij}	ij th element of the matrix $\tilde{D}(*,*,*)$
$E(*)$	continuous function related to ΔB
F	$3N \times N$ load distribution matrix for the augmented dynamic equation of the hydraulic actuators
F_i	3×1 load distribution matrix for the i th hydraulic actuator
I_N	$N \times N$ identity matrix
G	torsional spring constant of the hydraulic actuator
G_n	nonlinear spring constant of the hydraulic actuator
$G(*,*)$	$N \times 1$ vector of gravitational forces
G_i	i th component of the matrix $G(*,*)$

$\dot{G}(*,*)$	derivative of the matrix $G(*,*)$ with respect to time
$\widehat{G}(*,*)$	$N \times N$ matrix related to the vector of gravitational forces
$H(*)$	continuous function related to ΔA
I_{11}^i	moment of inertia at the centre of gravity of the i th link with respect to x-axis
I_{22}^i	moment of inertia at the centre of gravity of the i th link with respect to y-axis
I_{33}^i	moment of inertia at the centre of gravity of the i th link with respect to z-axis
J_m	hydraulic motor inertia
K_i	feedback gain matrix for the i th subsystem
K_t	total leakage coefficient of the hydraulic actuator
K_c	flow-pressure coefficient of the hydraulic actuator
K_q	flow gain of the hydraulic actuator
K_t	total leakage coefficient of the hydraulic actuator
K_v	servo valve gain
$M(*,*)$	$N \times N$ inertia matrix of the manipulator linkage
$\dot{M}(*,*)$	$N \times N$ derivative of the inertia matrix $M(*,*)$ with respect to time
M_{ij}	ij th element of the matrix $M(*,*)$
N	number of joints (degree of freedom)
$N(*,*,*)$	$3N \times 1$ nonlinear matrix for the integrated hydraulic robot manipulator
$N(*,*)$	$3N \times 1$ nonlinear matrix for the augmented dynamic equation of the hydraulic actuator the i th hydraulic actuator
$N_i(*,*)$	3×1 nonlinear matrix for the i th hydraulic actuator
$N_N(*,*)$	$3N \times 3N$ modified nonlinear matrix for the augmented dynamic equation of the hydraulic actuator
$N_{Ni}(*,*)$	3×3 modified nonlinear matrix for the i th hydraulic actuator
P_L	load pressure of the hydraulic actuator

P_s	supply pressure of the hydraulic actuator
Q_L	load flow of the hydraulic actuator
$S_\delta(*)$	continuous sign function to eliminate chattering
$SGN(*)$	discontinuous sign function
$T(*)$	$N \times 1$ vector of driving forces/torques applied by the actuators at the drive points on each link of the manipulator
$T_i(*)$	i th component of $T(*)$, driving forces/torques applied on the i th joint by the i th actuator
$\dot{T}(*)$	time derivative of the manipulator torque $T(*)$
$\dot{T}_i(*)$	i th component of $\dot{T}_i(*)$
$T_L(t)$	load torque on the motor shaft at the primary side of the i th motor
$\dot{T}_L(t)$	time derivative of the load torque on the motor shaft at the primary side of the i th motor
$U(*)$	$N \times 1$ control input vector for the i th actuator/ joint
$U_i(*)$	control input for the i th actuator/ joint
$U_{eq}(*)$	equivalent control
V_t	total compressed volume of the hydraulic actuator
$V(*)$	$\sum_{i=1}^N i \times N$ velocity matrix related to $D(*,*,*)$ vector
$\dot{V}(*)$	derivative of $V(*)$ with respect to time
$\hat{V}(*)$	$2N \times 1$ matrix related to coriolis and centrifugal velocity
W	$3N \times N$ rate of load distribution matrix for the augmented dynamic equation of the hydraulic actuator
W_i	3×1 rate of load distribution matrix for the i th hydraulic actuator
$X(*)$	state vector for the integrated electrohydraulic manipulator
$X_d(*)$	desired state trajectory
X_v	displacement of the spool in the servo valve of the hydraulic actuator
$Z(*)$	trajectory tracking error
$\dot{Z}(*)$	derivative of trajectory tracking error $Z(*)$ with respect to time
Z_{Bi}	$N \times 3N$ transformation matrix

$(*)^T$	transpose of $(*)$
$\ (*)\ $	Euclidean norm of $(*)$

2. LOWERCASE

a_{ij}	ij th term of the system matrix $A_N(*,*,*)$
a_{Bij}	ij th element of the system matrix A
b_{ij}	ij th term of the input matrix $B(*,*,*)$
b_{Bij}	ij th element of the input matrix B
c_i	i th sliding surface constant
f_{Bi}	i th element of the load distribution matrix F
g	gravity acceleration (ms^{-2})
l_i	length of the i th manipulator link (m)
m_i	mass of the i th manipulator link (kg)
n_{Bi}	i th element of the nonlinear matrix $N_i(*,*)$ for i th actuator
n_g	inverse of the gear ratio
n_{Bi}	i th element of the nonlinear matrix N
n_i	i th element of the nonlinear matrix $N(*,*,*)$
n_{Ni}	i th element of the modified nonlinear matrix $N_N(*,*,*)$
w	area gradient of the hydraulic actuator (m^2)
w_{Bi}	i th element of the rate of the load distribution matrix W
t	time
x_i	i th state variable for the manipulator linkage

3. GREEK SYMBOLS

α	norm bound of continuous function $H(*)$
β	norm bound of continuous function $E(*)$
β_e	effective bulk modulus of the oil of the hydraulic actuator
δ_i	i th continuous sign function constant
γ_i	i th controller parameters
λ_i	i th closed loop poles
λ_{\max}	maximum desired closed loop poles
$\Omega(*)$	Lebesgue function
σ	Integral sliding manifold
ρ	fluid mass density of the hydraulic actuator (kg/m^3)
τ	time interval for arm to travel from a given initial position to a final desired position (seconds)
$\theta_i(t)$	i th joint displacement
$\dot{\theta}_i(t)$	i th joint velocity
$\ddot{\theta}_i(t)$	i th joint acceleration
$\theta_{di}(t)$	desired i th joint displacement
$\dot{\theta}_{di}(t)$	desired i th joint velocity
$\ddot{\theta}_{di}(t)$	desired i th joint acceleration
θ_m	angular displacement of the motor shaft of the hydraulic actuator
$\dot{\theta}_m$	angular velocity of the motor shaft of the hydraulic actuator
$\ddot{\theta}_m$	angular acceleration of the motor shaft of the hydraulic actuator
ξ	uncertain payload mass carried by the robot manipulator (kg)

LIST OF ABBREVIATIONS

CTC	Computed Torque Control
DOF	Degree of Freedom
IJC	Independent Joint Control
ISMC	Integral Sliding Mode Control
LHP	Left Half Plane
PID	Proportional Integral Derivative
PISMC	Proportional Integral Sliding Mode Control
SMC	Sliding Mode Control

CHAPTER 1

INTRODUCTION

1.1 Robot Manipulator System

Robot is an important element in today's manufacturing and assembly industry. It is capable of performing many different tasks and operations precisely without requiring common safety and comforts that human need. In manufacturing, it can be used for many purposes since it can perform better than human and at lower costs. For an instance, a welder robot can weld better than a human welder as it is able to move more uniformly and more consistently. In addition, it does not require any protective clothing and many other necessities that human do. Robot is also best suited to work in hazardous environments where human cannot perform the tasks such as in exploring the ocean bottom in which, it can stay underwater for a much longer period and able to go deeper and withstand higher pressure; furthermore, it also does not require oxygen (Niku, 2001).

Robotic manipulator systems are driven by computers. Their motions are controlled by a controller that is under the supervision of the computer. The computer drives the robot to orient and position a tool or workpiece according to the positions and orientations required by a particular task (Niku, 2001).

The robotic system consists of several elements; the manipulator which is the main body of the robot, consisting of the links, joints and other mechanical structural elements of the robot, the end-effector which handles objects, the sensor that is used to collect information about the internal state of the robot or to communicate with the outside environment, the controller, the processor and the software which acts as the brain of the robot, and the actuator which functions as the muscle of the manipulators (Niku, 2001). The common types of actuators used are the electric motors, the pneumatic cylinders, and the hydraulic cylinders. Electric motors are the most commonly used robotic actuators; where as the pneumatic cylinders are used in robots that have $\frac{1}{2}$ DOF (Niku, 2001). On the other hand, hydraulic systems are very popular for large robots since they are capable of providing large torque and fast motion. This study focuses on the hydraulically driven robot manipulators.

1.2 Electrohydraulic Robot Manipulator

Although electrically driven robots are simpler in the overall design, there are many industrial tasks where hydraulic actuators can be used advantageously. Machinery in construction, forming, mining, forestry industry, heavy load motion control and mobile equipment applications as well as large flight simulators take the advantage of the high power to weight ratio, the stiffness and short response time provided by the hydraulic drives. For special applications such as very large robots and civil service robots, hydraulic actuator may also be an appropriate choice (Niku, 2001).

A hydraulic robot generally consists of hydraulic cylinders and rams which provide the forces or torques needed to move the joints and are controlled by the servo valves, a hydraulic pump which provides high-pressure fluid to the system, an electric motor which operates the hydraulic pump, a cooling system which rids the heat generated, a reservoir which keeps the fluid supply available to the system, a

servo valve that controls the amount and the rate of fluid to the cylinders; and is generally driven by a hydraulic servomotor, and sensors which are used to control the motion of the cylinders (Niku, 2001). Figure 1.1 illustrates a schematic drawing of a typical hydraulic system.

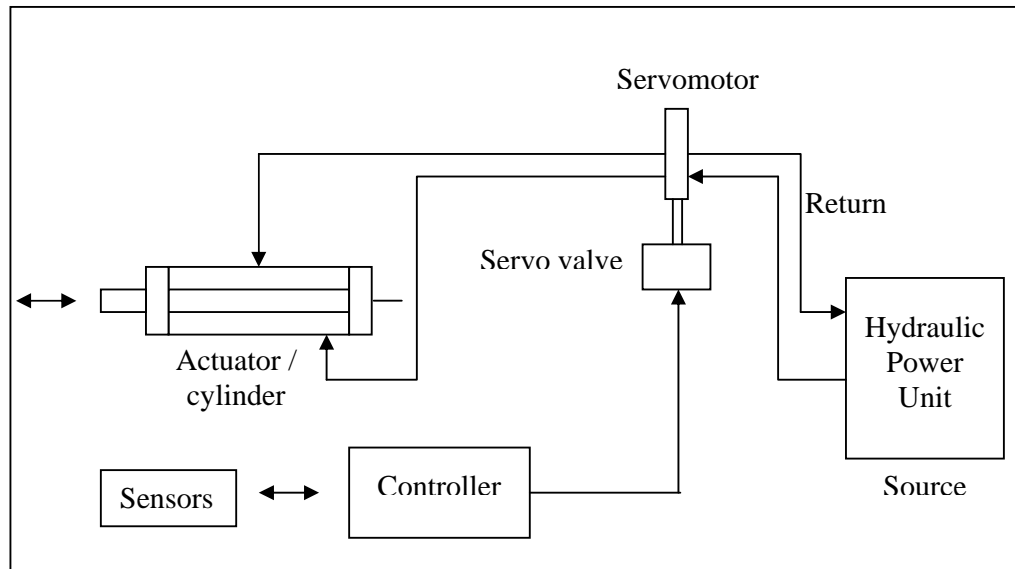

Figure 1.1: Schematic of a Hydraulic System and its Components

Figure 1.2 illustrates a hydraulic cylinder and a spool valve. A servo valve is created when a servomotor is attached to the spool valve. The servo valve and the cylinder together form a hydraulic servomotor. Simple movement of the spool valve controls the motion of the actuator. As the spool moves up or down, it opens the supply and return ports through which the fluid travels to the cylinder or returns to the reservoir. The amount of the supply fluid and thus the displacement of the cylinder can be controlled by adjusting the size of these ports opening. Similarly, the flow rate of the supply fluid and thus the velocity of the cylinder can be controlled by adjusting the rate of the ports opening (Niku, 2001).

The command to the servomotor in controlling the spool valve is provided by the controller. The controller calculates the distance and speed that a joint must

move and sets the current or voltage to the servomotor, which in turn, controls the position and the rate of movement of the spool valve, which in turn, controls the flow of the fluid and its rate to the cylinder, which moves the joint (Niku, 2001). A high control input voltage will produce large valve flow from the servo valve into the hydraulic motor. This will eventually results in a fast motion of the motor. The motor will in turn move the manipulator joint at high speed. Sensors are used to provide feedback to the controller.

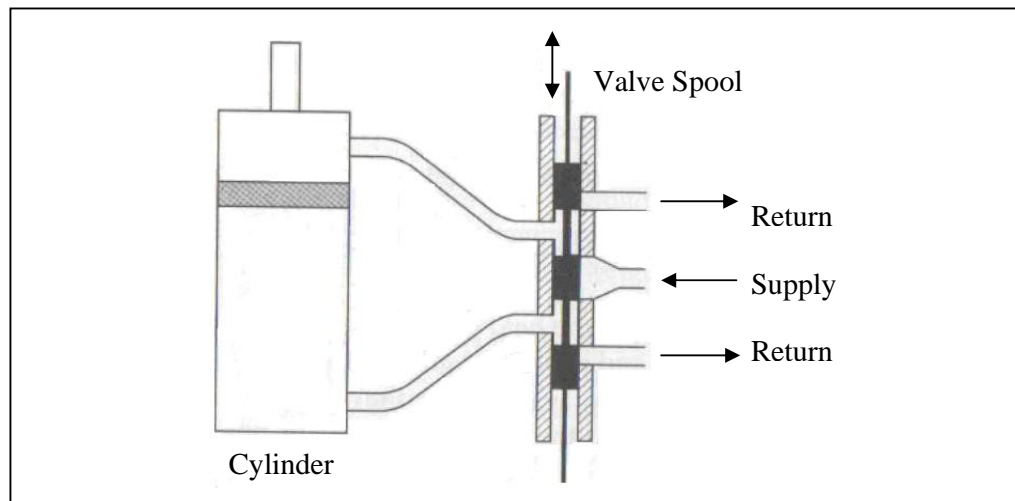

Figure 1.2: Schematic of a Spool Valve in Neutral Position

Most of the industrial applications of robot manipulators such as spray painting, spot welding and pick and place operations use position control. In such tasks, the manipulator is desired to follow a path (position and orientation) with timing restrictions. The timed path is called trajectory of the of the manipulator's end effector (Mendes et. al., 2002).

However, precise position control of hydraulic robot is difficult both theoretically and practically. In contrast to electric motor, in which the torque developed is proportional to electrical current or voltage, the torque developed by hydraulic actuators is proportional to the pressure difference or the flow rate towards the cylinder chamber which is in turn, determined by its spool position. In other

words, the control voltage or current signal to valve of hydraulic actuator controls the speed of the actuator rather than its force or torque directly. Furthermore, hydraulic system introduces additional nonlinearities to the control problem. Therefore, hydraulic dynamics are more complex than electrical motor dynamics. All of these factors make the modeling and control of such system a challenging task (Becker et. al., 2003).

As mentioned previously, the purpose of the manipulator control is to maintain the dynamic response of the manipulator in accordance with some pre-specified trajectory and desired system performance. The problem with present industrial position controllers is that its performance deteriorates when faster trajectories are demanded. In general, the dynamic performance of the hydraulic manipulator directly depends on the efficiency of the control algorithms and the dynamic model of the manipulator. The control problem consists of obtaining dynamic models of physical robot arm system and then specifying corresponding control laws or strategies so that the desired system response and performance can be achieved.

1.3 Manipulator Linkage Dynamic Model

In robotics system, dynamics is a study of the forces or torques required to cause the robot motion. In order to drive the manipulator to follow a particular trajectory, it is important that the actuators are capable of exerting large enough forces and torques to move the link fast enough, therefore avoiding the robot from losing its positional accuracy. In estimating the strength required by each actuator, it is necessary to determine the dynamic relationship that governs the motions of the robot.

In general, manipulator dynamic model can be derived from Newton-Euler formulation or Lagrange-Euler technique. However, it is very difficult to use Newtonian mechanics since the robots are three-dimensional, multiple degree of freedom (DOF) mechanism with distributed masses. Conversely, the derivation of the dynamic model of a manipulator based on Lagrange-Euler formulation is simple and systematic since it is based on energy term only. Furthermore, the Lagrange-Euler equations of motion provide explicit state equations for robot dynamics and can be utilized to analyze and design advanced joint-variable space control strategies (Niku, 2001).

Based on Lagrange-Euler formulation, the dynamics equation of an N DOF robot manipulator in the absence of the actuator dynamics, friction and other disturbances can be described as (Osman, 1991):

$$M(\theta(t), \xi)\ddot{\theta}(t) + D(\theta(t), \dot{\theta}(t), \xi) + G(\theta(t), \xi) = T(t) \quad (1.1)$$

where

$M(\theta(t), \xi)$: $N \times N$ inertia matrix
$D(\theta(t), \dot{\theta}(t), \xi)$: $N \times 1$ vector of coriolis and centrifugal forces
$G(\theta(t), \xi)$: $N \times 1$ vector of gravitational forces
$T(t)$: $N \times 1$ vector of generalized driving forces/ torques applied by the actuators at the drive points on each link of the manipulator
$\theta(t), \dot{\theta}(t), \ddot{\theta}(t)$: $N \times 1$ vector of generalized joint displacements, velocities and accelerations respectively
ξ	: a vector (with appropriate dimension) of parameters of the mechanism such as payload

The manipulator dynamic equation (1.1) describes the effect and importance of each term on the system dynamics in certain conditions. In the absence of gravity,

such as in space, the gravity terms may be omitted, but the inertia terms are critical. In the case where the robot moves slowly, the centrifugal and coriolis force terms may be negligible. For hydraulic manipulators, every term of the equation is significant in designing and controlling the robot to ensure satisfactory system performance.

From equation (1.1), it can also be seen that the actuator torque needed to drive the robot manipulator depends not only on the instantaneous joint acceleration, but also the inertia, centrifugal, coriolis and gravitational forces. The inertia, centrifugal, coriolis and gravitational forces, in turn, are functions of the dynamic parameters of the manipulator as well as the instantaneous position and velocity of the links and uncertain payload mass. Therefore, it can be deduced that the dynamics model describing the manipulator system is strongly time varying, nonlinear and contains uncertainty. It also suffers from of coupling effect, resulting from the dynamic interactions among the links of the manipulator arm.

Majority of earlier work in the synthesis of control law for manipulators deal with electrically actuated manipulators. In terms of hydraulic robots, comparatively less work has been done (Sirouspour and Salcudean, 2001). Previous research has spanned both modeling and control of general hydraulic servo systems with no robotic manipulator dynamics considered in the model. For example, Zhu and Piedbouf (2005) proposed Adaptive Control Technique to control hydraulic cylinders with the application to robot manipulators, but none of the mechanical linkage dynamics are incorporated in the modeling. Chern and Wu (1991) provide a more closely behaviour of a real hydraulic motor representation in which more parameters of the actuator such as the motor inertia, damping coefficient and spring stiffness are taken into account. However, instead of incorporating the manipulator dynamics in the proposed mathematical model, the design just assumed the load torque as a function dependent upon the shaft velocity, which is frequently found in industrial process. The same situation can be found in Kim (2000), where the load torque is not formulated by using the mathematical representation of the robot manipulator, but rather estimated by utilizing the output signal of piston displacement.

However, the dynamics of the actuator alone is not sufficient to represent the hydraulic manipulator, since it does not include the arm dynamic forces such as inertia forces and gravity effects that the controller needs to compensate. Tracking performance of the system may be improved by incorporating the robot dynamic model in the controller design since it is part of the hydraulic servo system. This approach has been successfully shown in many electrical robots in the past (Honegger and Corke, 2001).

There are actually some previous works that incorporates the manipulator dynamics in the modeling step but with limited number of hydraulic parameters being taken into consideration. For example, in Habibi (1994) and Zhou (1995), 6 DOF and 2 DOF hydraulic robot arm models are developed respectively. The models incorporate manipulator dynamics, but the hydraulic motor nonlinear spring stiffness, viscous damping and inertia are not taken into account in the design.

Therefore, in terms of modeling, this study presented a mathematical formulation of an integrated dynamic model for an N DOF hydraulically driven robot manipulator that integrated both the actuator dynamics and the mechanical arm dynamics, and at the same time considered the hydraulic motor nonlinear spring stiffness, viscous damping and inertia. The proposed model is believed to provide a better and much more suitable mathematical representation for the hydraulic robot for the purpose of controller synthesis and analysis. A 3 DOF electrohydraulic robotic manipulator is used in the formulation as an example.

1.4 Electrohydraulic Manipulator Control Strategies

Control strategies for robotic control system are of great interest for both industrial and academic fields. Various advanced and sophisticated methods have

been proposed by numerous researchers in providing the tracking control of robot manipulator such that it follows a prescribed trajectory as closely as possible and at the same time guarantees the system stability.

Early investigations on hydraulically driven robot arm are based on a linearised model as can be found in Hoffman (1979) and Sepehri (1990). Since many assumptions are made as to eliminate the nonlinearities present in the system, the proposed algorithm is impractical due to the fact that the plant is highly nonlinear. Also in the approach, the coupled and time-varying dynamics of the mechanical part of the robot manipulator system are ignored, or assumed as disturbances. However, when the links are moving simultaneously and at high speed, the coupling effects and the interaction of forces between the manipulator links may decrease the performance of the overall system and increase the tracking error (Osman, 1991). The controller developed is also lack of global stability proofs that are important from both theoretical and implementation points of view (Sirouspour and Salcudean, 2001). The proofs are also missing in the decentralised control laws that are presented by Edge and DeAlmeida (1995).

Zhou (1995) has carried out experimental evaluations on PID and Computed Torque Control (CTC) strategies for the hydraulic robot and has concluded that both methods give unsatisfactory performance. The problem with PID controllers is that they are not adequate for the cases when the robot moves at high speed and in situations requiring a precise trajectory tracking. On the other hand, the problem with CTC is that it can only be applied to robots allowing joint torque control. Furthermore, as the computed torque control is essentially based on exact robot arm dynamic model, the explicit use of an incorrect robot model will deteriorate the control performance. He further developed the Kinematic Compensation Control incorporating a feedforward kinematic compensation and conventional regulatory control techniques. The control input consists of two parts: a feedforward kinematics compensation and a conventional feedback control. Although the system exhibits good experimental result, it still lack of mathematical stability proof.

Bu and Yao (2000) proposed a Lyapunov based Model-based Adaptive Control for controlling the hydraulic manipulator. The design possesses mathematical stability proof but it needs persistent excitation and pressure feedback. A strategy based on Backstepping approach has been developed by Sirouspour (2001). The design is said to be sensitive to sensor noise, therefore high-quality measurements are necessary. One possibility to overcome this drawback is by introducing heuristic limitation of time derivatives in the control law. This method reduces the influence of sensor noise in the simulations significantly, but leads to a slight reduction of the control performance (Becker et. al., 2003).

Habibi (1994) developed Computed Torque Control and Sliding Mode Control technique with specific application to 6 DOF hydraulic manipulator model that he established earlier. In contrast to the first control method, the latter approach gives satisfactory performance for that particular robot. However, the controller is derived based conventional SMC algorithm; therefore the system has no insensitivity property during the reaching phase.

The extended version of conventional SMC technique which is known as the Integral Sliding Mode Control (ISMC) or Proportional Integral Sliding Mode Control (PISMC) has emerged in the literature (Ahmad, 2003). Similar to conventional SMC, it is suitable for complex systems and is insensitive to parameters variations and uncertainties. However, it also overcomes the problem of reduced order dynamics. Different from the conventional SMC design, the order of the motion equation in ISMC is equal to the order of the original system, rather than reduced by the number of dimension of the control input. The method does not require the transformation of the original plant into the canonical form. Moreover, by using this approach, the robustness of the system can be guaranteed throughout the entire response of the system starting from the initial time instance. The method has been successfully applied in a variety of control systems (Ahmad, 2003).

The PISMC method has been successfully designed for electrically driven robot manipulator as presented in Ahmad (2003), Ibrahim (2004) and Karsa (2005). In Ahmad (2003) a three DOF revolute robot dynamics has been used in the simulations. It is verified that the proposed control law is effective in providing the tracking control and efficient in compensating the nonlinear, coupled and time varying inertia, coriolis, centrifugal and gravitational forces of the mechanical manipulator linkage. The stability proofs based on Lyapunov theory are also presented in this study.

This project extends the control strategy proposed in controlling three DOF electrically driven robot manipulator of Ahmad (2003) in providing the trajectory tracking control of a hydraulically actuated robot manipulator. The developed controller will not only consider the nonlinear property of both the hydraulic dynamics and the manipulator mechanical dynamics but also stable based on Lyapunov theory. In evaluating the effectiveness of the control strategy, the controller will be applied to control a three DOF electrohydraulic robot manipulator. Rigorous simulations will be conducted to show that the proposed techniques is capable of successfully compensating the system's nonlinearities, parameter variations, external uncertainties and coupled effect in providing the necessary position trajectory tracking control for the robotic system.

1.5 Objective

The objectives of this project are:

- i) To give a mathematical formulation in deriving the integrated model of an electrohydraulic robot manipulator in state space representation taking into consideration both the manipulator and actuator dynamics,

- ii) To adopt a robust control strategy based on Proportional Integral Sliding Mode Control (PISMC) technique to control the position trajectory of the electrohydraulic manipulator so that it tracks the desired trajectory as closely as possible for all times in spite of parameter variation, uncertainties and nonlinearities present in the system,
- iii) To investigate the performance of the proposed approach compared to existing Independent Linear Joint Control Technique in controlling the electrohydraulic robotic manipulator system through computer simulations.

From the study performed, it will be shown that the proposed technique will efficiently force and control the hydraulic manipulator to follow the desired position trajectory for all times in spite of the nonlinearities and uncertainties present in the system.

1.6 Scope of Project

The scope of work for this project includes:

- i) Formulating of an integrated dynamic model for an N DOF hydraulic robot in state space representation and deriving a mathematical model for a 3 DOF revolute electrohydraulic robot manipulator in state space representation, which involves the:
 - a) Robot manipulator dynamics as described in Osman (1991).
 - b) Electrohydraulic actuator dynamics as described in Chern and Wu (1991).
- ii) Designing of the Proportional Integral Sliding Mode Controller (PISMC) as described in Ahmad (2003) and its application to the

plant as described in part (i) in controlling the system tracking trajectory.

- iii) Designing of the Independent Linear Joint Controller (IJC) which is used as a comparison in analyzing the performance of the controller in part (ii)
- iv) Simulation study conducted in SIMULINK, MATLAB 7.0 to investigate the effectiveness of the approach in part (ii) in providing the necessary control for the system in part (i)

1.7 Research Methodology

The research work is undertaken in the following six developmental stages:

- i) Development of an integrated mathematical model of an N DOF revolute hydraulic robot manipulator. The steps taken in this stage are:
 - a) Conduct literature review on the existing robot manipulator mechanical linkage mathematical model
 - b) Conduct literature review on the existing hydraulic actuator mathematical model
 - c) Conduct literature review on the existing electrohydraulic robot manipulator mathematical model
 - d) Integrate the robot manipulator mechanical linkage mathematical model found in Osman (1991) and hydraulic actuator mathematical representation presented by Chern and Wu (1991) based on the procedure outlined in Osman (1991) in state space representation
 - e) Determine the complete mathematical model of a 3 DOF revolute electrohydraulic robot manipulator.

- ii) Application of a robust controller based on PISMC technique to the robotic system. The steps taken in this stage are:
- a) Conduct literature review on the existing control technique for robotic systems
 - b) Conduct literature review on the existing robust control technique based on Proportional Integral Sliding Mode Control algorithm
 - c) Implement PISMC technique cited from Ahmad (2003) to the hydraulically actuated robotic system. The procedures performed in this stage are:
 - Decomposing the complete model into an uncertain model
 - Defining the sliding surface
 - Determination of the system dynamics during Sliding Mode
 - Application of the established final control law to the electrohydraulic robot.
- iii) Perform various simulation of the proposed controller on MATLAB platform with SIMULINK as its user interface. The simulation performance of the PISMC is compared to the IJC and analysed.

1.8 Structure and Layout of Thesis

This thesis is organized into five chapters. Chapter 2 deals with the formulation of the mathematical modeling of the integrated N DOF electrohydraulic robot manipulator, in which, firstly a general dynamic model of a rigid manipulator link and the hydraulic actuator dynamics are described separately. Then, based on these equations, an integrated model formulated in state space representation is presented. Finally, a complete integrated dynamic model for a three DOF revolute electrohydraulic robot is determined.

In Chapter 3, the controller design using proportional integral sliding mode control technique with specific application to the plant as described in Chapter 2 is presented. A systematic approach and basic assumptions taken while establishing the control law are outlined in this chapter.

Chapter 4 discusses the performance evaluation of the control system by means of computer simulation using MATLAB/ SIMULINK. The simulation begins with a pre-specified desired trajectory for each of the manipulator joints. In order to clearly analyze the performance of the proposed controller, Independent Joint Linear Control (IJC) technique is used as a mean of comparison. Conclusion on the effectiveness of the approach in handling the parameter variations, nonlinearities, uncertainties and couplings present in the plant and thus providing the necessary tracking control for the system is also made and discussed based on the results obtained in this chapter.

The thesis ends with Chapter 5, where the summary of the approach adopted while undertaking this project is described. Recommendations for future work are also presented in this final chapter.

REFERENCES

- Ahmad, N.M. (2003). *Modeling and Control of Direct Drive Robot Manipulator*. Universiti Teknologi Malaysia: Ph.D. Thesis.
- Ambrosino G., Celetano, G., and Garofalo F. (1984). Variable Structure Model Reference Adaptive Control Systems. *International Journal of Control*. 39(6): 1339-1349.
- Becker, O., Pietsch, I., and Hesselbach, J. (2003). Robust-Task Space Control of Hydraulic Robots. *Proceedings of the 2003 IEEE International Conference on Robotics And Automation*. September 14-19. Taipei, Taiwan: IEEE, 4360-4365
- Bolton, W. (1999). *Mechatronics: Electronic Control Systems in Mechanical and Electrical Engineering*. 2nd Edition, England: Prentice Hall.
- Bu, F., and Yao, B. (2000). Observer Based Coordinated Adaptive Robust Control Of Robot Manipulators Driven By Single-Rod Hydraulic Actuators. *Proceedings of the IEEE, International Conference on Robotics and Automation*. April. San Francisco, CA: IEEE, 3034-3039.
- Chern, T. L., and Wu, Y. C. (1991). Design of Integral Variable Structure Controller and Application to Electrohydraulic Velocity Servosystems. *IEE Proceedings*. 138(5): 439-444.
- DeCarlo, R. A., Zak, S. H., and Matthews, G. P. (1988). Variable Structure Control of Nonlinear Multivariable Systems: A Tutorial. *Proceedings of the IEEE*. 76(3): 212-232.
- Edwards, C., and Spurgeon, S. K. (1998). *Sliding Mode Control: Theory and Applications*. London: Taylor & Francis Group Ltd.

- Edge, K. A., and DeAlmeida, F. G. (1995). Decentralised Adaptive Control of a Directly Driven Hydraulic Manipulator. *Journal of Systems and Control Engineering*. 207:197-205.
- Fung, R.F., Wang, Y.C., Yang, R.T., and Huang, H.H. (1997). A variable Structure Control with Proportional And Integral Compensation for Electrohydraulic Position Servo Control System. *Mechatronics*. 7(1): 67-81.
- Habibi, S. R., and Goldenberg, A.A. (1994). Analysis and Control of Industrial Hydraulic Robots. *Proceedings of the IEEE 1994 33rd Conference on Decision and Control*. December. Lake Buena Vista, FL,: IEEE, 345-350.
- Hoffman, R. (1979). Dynamics and Control of A Flight Simulator Motion System. *Canadian Conference on Automatic Control*. May 23-24. Montreal, Canada.
- Honegger, M., and Corke, P. (2001). Model Based Control of Hydraulically Actuated Manipulators. *Proceedings of the 2001 IEEE International Conference on Robotics and Automation*. May 21-26. Seoul, Korea: IEEE, 2553-2559.
- Ibrahim, B. S. K. (2004). *Control of A 2 D.O.F Direct Drive Robot Arm Using Integral Sliding Mode Control*. Universiti Teknologi Malaysia: M.Eng. Thesis.
- Karsa, M. N. M. M. (2005). *Simulation Study of An Advanced Control Strategy For A PUMA Like Robot Manipulator*. Universiti Teknologi Malaysia: M.Eng. Thesis.
- Kim, C. S. (2000). Robust Speed Control of A Variable-Displacement Hydraulic Motor Considering Saturation Nonlinearity. *Journal of Dynamic Systems, Measurement and Control*. 122: 196- 201.
- Mendes, M. F., Kraus, W. J., and Pieri, E. R. (2002). Variable Structure Position Control of An Industrial Robotic Manipulator, *Journal of the Brazillian Society of Mechanical Sciences*. 24(3).
- Merrit, H. E. (1967). *Hydraulic Control Systems*. New York: John Wiley and Sons.
- Ngadengon, R. (2005). *A Full Order Sliding Mode Tracking Controller Design for An Electrohydraulic Control System*. Universiti Teknologi Malaysia: M.Eng. Thesis.
- Niku, S. B. (2001). *Introduction to Robotics: Analysis, Systems, Application*. New Jersey: Prentice Hall.
- Osman, J. H. S. (1991). *Decentralized and Hierarchical Control Of Robot Manipulators*. City University London: Ph.D. Thesis.

- Sirouspour, M. R., and Salcudean, S. E. (2001). Nonlinear Control of Hydraulic Robots. *IEEE Transactions on Robotics and Automation*. 17(2): 173-182.
- Sam, M. Y. (2003), *Modeling And Control Of Active Suspension System Using Proportional Integral Sliding Mode Control*. Universiti Teknologi Malaysia: Ph.D. Thesis.
- Sepehri, N., Dumont, G. A. M., Lawrence, P. D., and Sassani F. (1990). Cascade Control of Hydraulically Actuated Manipulators. *Robotica*. 8:207-216.
- Yan, J.J, Tsai, J.S.H., and Kung, F.C. (1997). Robust Decentralized Stabilization of Large Scale Delay System via SMC. *Journal of Dynamic Systems, Measurement and Control* .119:307-312.
- Zhou, J. (1995). Experimental Evaluation of A Kinematic Compensation Control Method for Hydraulic Robot Manipulators, *Control Engineering Practice*. 3(5): 675-684.
- Zhu, W. H., and Piedbouf, J.C. (2005). Adaptive Output Force Tracking Control of Hydraulic Cylinders with Applications to Robot Manipulators. *ASME Journal of Dynamic Systems, Measurement and Control*. 127: 206-217.