

# Iterative Data Detection and Channel Estimation for Single-Parity Check-Product Coded MIMO Wireless Communications System

Muladi\*, N. Faisal, S. K. Yusof

Department of Telematics and Optic Communications  
Fac. of Electrical Eng., Universiti Teknologi Malaysia,  
Johor Bahru, Malaysia  
email: \*muladi@gmail.com

**Abstract:** In iterative data-detection and channel-estimation algorithms, the channel estimator and the data detector recursively exchange the information order to improve the system performance. In this paper, maximum a posteriori based iterative data detection and pilot symbol assisted channel estimation of the single parity check product code for multiple antenna wireless communication is studied. Results show the algorithm can converge at a few iteration numbers and improve error probability performance of the system.

*Index Terms:* multiple antennas, single-parity check codes, product code, iterative decoding, pilot symbol assisted channel estimation.

## I. INTRODUCTION

The joint iterative data-detection and channel estimation appears to be a suitable means to achieve excellent performance in wireless communication system, where the length of the training sequence or pilot symbols is to be kept as small as possible to maintain the data throughput is still high. Basically, iterative schemes (which are usually denoted through the adjective “turbo”), the channel estimator and the data detector recursively exchange information in order to improve the system performance.

The explosive growth of wireless communication services, such as mobile computing and wireless Internet, as well as the deployment of wireless local area network (WLAN), has resulted in an in bandwidth-efficient high-data-rate transmission system. Recent results from information theory have shown that capacity of a multiple antennas wireless communication system operating in a rich scattering environment grows with a law approximately linear in minimum between the number of transmit and receive antennas [1]. Likewise, high-performance space-time diversity systems have been recently introduced, which permit the system to achieve huge performance gains with respect to single-antenna communication system (see. e.g [2], [3], and [4]).

Some layered space-time architectures have been proposed in order to exploit the benefit of the multiple antenna system promise in theory and their potential gains over single antenna systems. Among these, the most popular one has been termed Bell Labs Layered Space-Time Architecture (BLAST) [5]. This system has attracted much attention in the last ten years

and several papers have appeared in the open literature, presenting theoretical finding and/or performance results for BLAST-like system.

In our previous work [6], the full-rate space-time diversity scheme have been proposed. Compare to the system using space-time block codes [3], the proposed scheme has advantage that guarantee the transmission rate will always equal to 1 symbol/Hz/s. This paper extends these previous results by increasing the bit rate and develops the channel estimation. One alternative in increasing bit rate uses high-rate code as component code of the product code but it provides low error rate.

The work in this paper uses the single-parity-check code (SPC) as component code, parallel concatenated, of product code (PC). SPC is simple, but weak, algebraic code. The SPC-PC codes are high-rate codes when reasonable block lengths are used. They are simple to encode and decode and have been shown to produce good performance. Maximum a posteriori (MAP) decoded multidimensional SPC-PC were shown to have very good performance in [7].

By taking the output of the SPC-PC encoder into two defined-interleavers and transmitting through multiple transmit antennas, will provide space and time diversity in the system. Pilot-symbol aided channel estimation is used to measure the channel impulse response. Following the iteration of the decoding process, the channel impulse response will be updated by employing the extrinsic information output of the decoder. The convergence of this channel impulse response update will investigate.

## II. SYSTEM MODEL

Figure 1 depicts the discrete time model of proposed system diagram. At the transmitter, the data stream is formatted into a block data with size of  $k_r \times k_c$ , where  $k_r$  is the data length in rows and  $k_l$  is the data length in column. Each row and column of data is encoded using single parity check code (SPC) to be a  $(k_r+1, k_r, 2)$  for row and  $(k_c+1, k_c, 2)$  for column. The encoding process in rows and columns are to be independent thus the check on check parity bit is not generated [7]. Without lost of generality, in this paper it sets  $k_r = k_c = k$ .

The encoded data stream output to two systematic interleavers that defined by the row-wise reading and column-wise reading (see [6]). These data streams are then mapped into  $S$ -symbol of constellation elements,  $s$ . The  $L$  number of pilot symbols  $p$  are inserted at each  $l$  data information to provide the channel response measurement. The resulted blocks have the following format:

$$x = [p_1 \underbrace{s_1 \dots s_l}_I p_2 \underbrace{s_{l+1} \dots s_{2l+1}}_I p_3 \dots p_L] \quad (1)$$

These blocks are transmitted through each branch of transmit antenna. The distance Each transmit antenna uses the same amount of energy and that totally equal to transmitted energy of the single transmit antenna system. It is assumed that the transmit antennas are far-separated enough thus each path between transmit and receive antennas are independent.

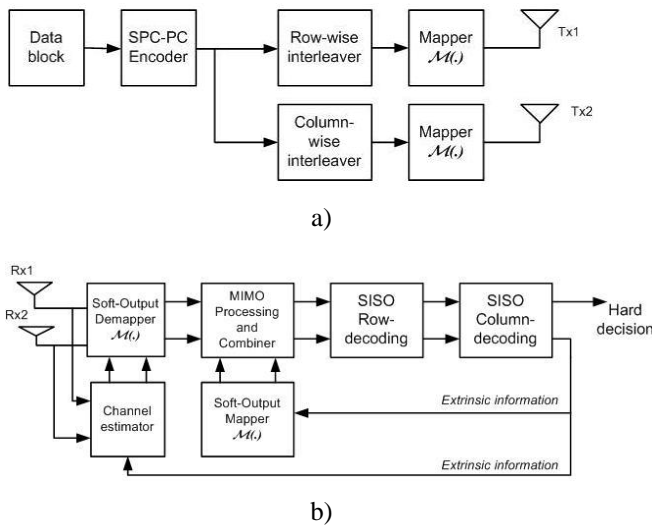

Figure 1 Proposed System diagram, a) transmitter, b) receiver.

The receiver employs a number of antennas that equal to the number of transmit antennas at the transmitter. The received complex base-band samples at the received antenna  $n$  are presented by:

$$r_n = \sum_{m=1}^2 h_{m,n} x_m + w_n \quad (2)$$

where  $x_m$  is transmitted block symbols from transmit antenna  $m$ . While  $w_n$  is an additive noise, Gaussian distributed with mean zero and variance  $N_o/2$  when the transmitted bit energy is  $E_b/N_o$ .

Assuming that the transmit antennas are separated enough as well as the receive antennas, thus the link between each transmit and each receive are independent. This link is in a rich scattering environment that consists of multiple paths but no line of sight component and modeled as a wide-sense-stationary complex Gaussian process with zero mean, which makes the marginal distributions of the phase and amplitude at any given time uniform and Rayleigh, respectively, hence the term Rayleigh fading.

### III. DATA RECOVERY AND ITERATIVE DETECTION

One block of data information are interleaved by two interleavers and transmitted from two transmit antennas. By using explicit notation, (2) can be rewritten as:

$$\begin{aligned} r_1 &= h_{11}x_1 + h_{21}x_2 + w_1 \\ r_2 &= h_{12}x_1 + h_{22}x_2 + w_2 \end{aligned} \quad (3)$$

The estimated received symbols are obtained by combining the received signals,

$$\begin{aligned} \hat{x}_1 &= h_{11}^* r_1 + h_{21}^* r_2 \\ \hat{x}_2 &= h_{12}^* r_1 + h_{22}^* r_2 \end{aligned} \quad (4)$$

Where  $(.)^*$  is conjugate operator. Soft-output de-mapping process yields the estimated bit sequences as follow:

$$\begin{aligned} \hat{b}_1 &= M^{-1}(\hat{x}_1) \\ \hat{b}_2 &= M^{-1}(\hat{x}_2) \end{aligned} \quad (5)$$

Where  $(M)^{-1}$  is demapping. Remember that the transmitted bit sequence from transmit antenna one is same with the transmitted bit sequence from antenna two, but interleave at different position prior to mapping process and transmission.

The decoding process starts by calculating the log-likelihood ratio (LLR) of two received sequences,

$$L(d|\hat{b}_1) = \log_e \left[ \frac{P(d=+1|\hat{b}_1)}{P(d=-1|\hat{b}_1)} \right] \quad (6)$$

$$L(d|\hat{b}_2) = \log_e \left[ \frac{P(d=+1|\hat{b}_2)}{P(d=-1|\hat{b}_2)} \right] \quad (7)$$

Where  $d$  represents the transmitted data bits. The computation of (7) and (8) are same, thus it can be presented in general. Using Bayesian rule, (7) and (8) to be:

$$\begin{aligned} L(d|\hat{b}) &= \log_e \left[ \frac{p(\hat{b}|b=+1)P(d=+1)}{p(\hat{b}|b=-1)P(d=-1)} \right] \\ &= \log_e \left[ \frac{p(\hat{b}|d=+1)}{p(\hat{b}|d=-1)} \right] + \log_e \left[ \frac{P(d=+1)}{P(d=-1)} \right] \\ &= L_c(\hat{b}) + L(d) \end{aligned} \quad (8)$$

Assuming all bits are equal likely, the second term can be ignored. This will be used as the channel LLR  $L_c(b)$ . For statistically independent transmission of the dual diversity system, the LLR channel is [7]:

$$L_c(\hat{d}) = L_c(\hat{b}_1) + L_c(\hat{b}_2) + L(d) \quad (9)$$

where  $L_c(\hat{d})$  is simplified version of  $L_c(d|\hat{b})$ . The LLR output (soft output) of the decoder is equal to [8]:

$$L(\hat{d}) = L_c(\hat{d}) + L_e(\hat{d}) \quad (10)$$

where  $L_e(\hat{d})$  is extrinsic LLR obtained from row and column decoding. From [6] and [8], the extrinsic LLR is:

$$L_e(\hat{d}_j) = \log \frac{\Lambda(p+1) \prod_{i=1, i \neq j}^k (\exp(L(\hat{d}_i)) + 1) + \Lambda(p-1) \prod_{i=1, i \neq j}^k (\exp(L(\hat{d}_i)) - 1)}{\Lambda(p+1) \prod_{i=1, i \neq j}^k (\exp(L(\hat{d}_i)) + 1) - \Lambda(p-1) \prod_{i=1, i \neq j}^k (\exp(L(\hat{d}_i)) - 1)} \quad (11)$$

where:

$$\begin{aligned} \Lambda(p+1) &= \exp(L_c(p)) + 1 \\ \Lambda(p-1) &= \exp(L_c(p)) - 1 \end{aligned} \quad (12)$$

where  $L_c(p)$  is LLR channel of the parity bit at the same row or column of the  $d_j$ . At the last iteration, the soft output of the decoder is:

$$L(\hat{d}_j) = L_c(\hat{d}_j) + L_{er}(\hat{d}_j) + L_{ec}(\hat{d}_j) \quad (13)$$

The hard decision value of this data bit can be obtained by applying the sign function to (13).

#### IV. CHANNEL ESTIMATION AND PILOT SEQUENCE DESIGN

Equation (3) can be represented in matrix form as follows:

$$\mathbf{R} = \mathbf{H}\mathbf{X} + \mathbf{W} \quad (14)$$

This relation gives one possible way to measure the channel response. The transmitted block  $\mathbf{X}$  consists of a few number of pilot symbol,  $x_p$ , that the receiver knows the pilot value and its position within the block. A particular pilot symbol will help to measure the channel impulse response and the pilot positions will define the time of those response occurrences. The channel impulse responses will be obtained by inverting the pilot symbol matrix,  $\mathbf{X}_p$ , that the elements of this matrix are pilot symbol from antenna one and two.

$$\mathbf{X}_{p2} = \begin{bmatrix} p_{11} & p_{12} \\ p_{21} & p_{22} \end{bmatrix} \quad (15)$$

This matrix define the minimum number of pilot symbol that should be inserted into the transmitted data block, thus the channel impulse response measurement can be performed.

In order simplified computation of the channel impulse response, this paper sets the pilot symbol are orthogonal in time. In particular, the simplest pilot symbol matrixes are:

$$\begin{bmatrix} p_{11} & 0 \\ 0 & p_{22} \end{bmatrix} \quad \text{or} \quad \begin{bmatrix} 0 & p_{12} \\ p_{21} & 0 \end{bmatrix}$$

Once the channel impulse responses at particular time are achieved, the channel response at a whole transmitted block can be obtained by using interpolation, where the number of pilot symbol define the accuracy of the generated samples.

$$\mathbf{H} = \mathbf{X}^{-1}(\mathbf{R} - \mathbf{W}) \quad (16)$$

As described at previous section, the iterative data detection results the extrinsic information of data that will update the received bits value ( $L_c + L_e$ ). Soft-mapping these bit sequence to the constellation elements of  $S$  (soft-values). By using equation in (5), the new channel impulse response can be calculated. Thus the channel impulse responses are also updated iteratively together with the data detection process.

#### V. SIMULATION RESULT AND DISCUSSION

Simulation results are now presented for the proposed scheme. It begins with comparing the error rate performance of the proposed system with single antenna system. The PC uses SPC with  $k = 8$  and the flat Rayleigh fading channel is assumed. Figure 2 is shown that the proposed system has 2 dB power advantageous than single antenna system to achieve bit error rate (BER) at  $2 \times 10^{-5}$ . Each decoding iteration gave improvement on BER. A significant improvement is obtained after iteration number 3. After that the iteration is not improve the BER performance significantly or no improvement. It has been investigated in [9], that the effective iteration number of 2 dimensional SPC-PC is 3. The curve shows at  $E_b/N_0$  6 dB, the second iteration gives  $1 \times 10^{-5}$  error probability less than the second iteration, while less error probability for  $6 \times 10^{-5}$  gives by the third iteration, and  $1 \times 10^{-5}$  gives by the forth iteration.

Figure 3 shows error rate performance of the proposed system with different number of pilot symbol within one block of data information. The channel is a Rayleigh distributed flat fading and is assumed to be invariant during one symbol period. Number of pilot symbols compare to the number of symbols in one data block is presented in percentage. For the number of pilot symbols equal to data symbols (50%), gives BER  $2 \times 10^{-5}$  at  $E_b/N_0$  6 dB, while perfect channel estimation gives  $3 \times 10^{-6}$ . This error performance decreases significantly as decreasing the number of pilot symbols. If half number of pilot symbols is employed, the error performance will decrease to  $2 \times 10^{-5}$ . Furthermore, the error rate performance will decrease to  $1 \times 10^{-4}$  if the number of pilot symbol is a quarter of transmitted block length, and  $2 \times 10^{-3}$  if the number of pilot is one over eight of the length of transmitted block. These results confirmed that higher number of pilot symbols will give higher error rate performance in the cost of lower rate transmission.

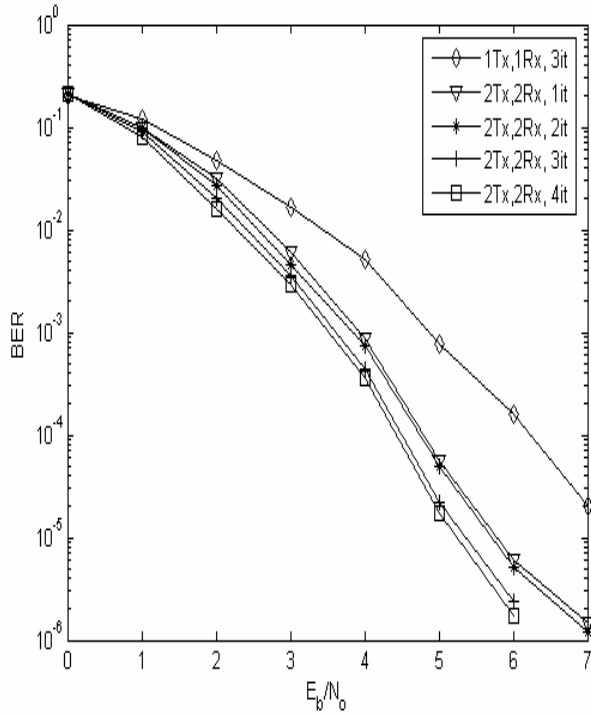

Figure 2 Performance of the proposed system when the channel is perfectly estimated.

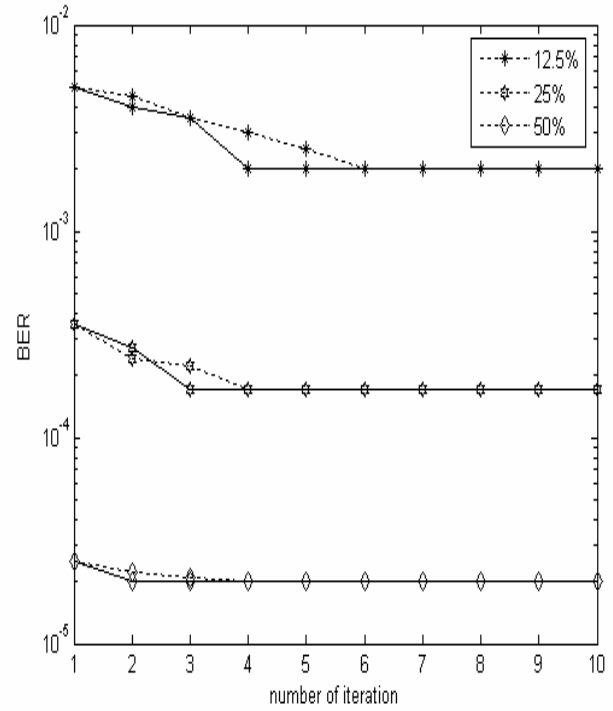

Figure 4 Convergence curve of the iterative data decoding and channel estimation; dash-line: without channel response update, full-line: with channel response update.

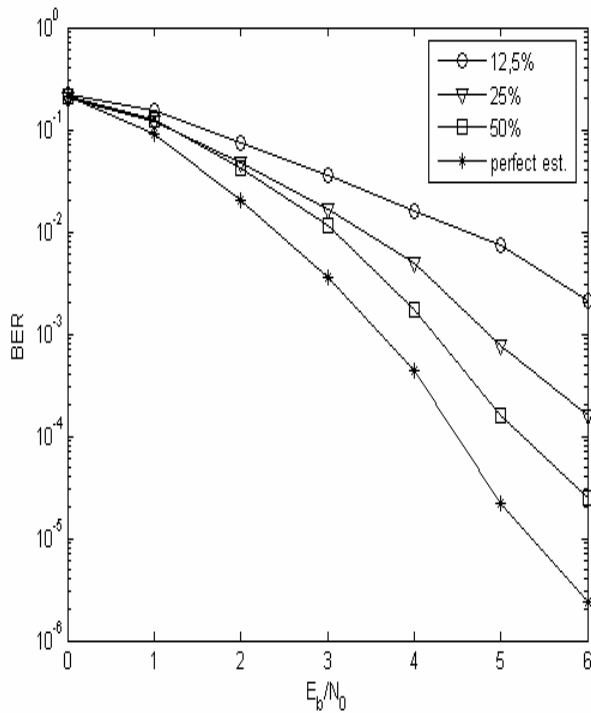

Figure 3 Performance of the proposed system employing a numbers of pilot symbols compared to the length of the transmitted block.

Next, we investigate convergence of the iterative decoding algorithm when the channel is not perfectly measured. As it is shown in Figure 4, the decoding algorithm will converge after 5 iterations. Since more accurate information of channel is available, then the algorithm will converge faster. In this case, the information of the channel is brought by pilot symbol in the transmitted block. The algorithm will converge at second iteration when the number of pilot is equal to the number of data symbol in the transmitted block (50% of block length). Higher number of iteration is required to reach the algorithm convergence when employ a few number of pilot symbols. Three and five iterations are required when the number of pilot symbols is a quarter and one over eight of the transmitted block, respectively. Although these number iteration are still reasonable but the error rate performances are low.

## VI. CONCLUDING REMARKS

The application of SPC-PC in multiple antennas system was introduced. Using two different interleavers based on row-reading and column reading [6], the proposed system provided the space-time diversity. Decoding of the received data can be performed iteratively based on MAP criterion. Performance of the proposed system is much better than single antenna system.

Pilot symbol can employed to estimate the channel impulse responses that required at signal processing and data decoding in the proposed system. Accurate channel estimation will be given by employing large number of pilot symbol in the transmitted block. By using extrinsic information of iterative data decoding to update the channel impulse response, the decoding process will converge faster.

## REFERENCES

- [1] G. J. Foschini and M. J. Gans, "On limits of wireless communications in a fading environment when using multiple antennas", in *Wireless Personal Communications*, 1998, vol. 6, pp. 311-335.
- [2] V. Tarokh, N. Seshadri, and A. R. Calderbank, "Space-time codes for high data rate wireless communication: Performance criterion and code construction", *IEEE Trans. Inform. Theory*, vol. 44, pp.744-765, March 1998.
- [3] V. Tarokh, H. Jafarkhani, and A. R. Calderbank, "Space-time block codes from orthogonal designs," *IEEE Trans. Inform. Theory*, vol. 45, pp. 1456-1467, July 1999.
- [4] G. Raleigh and J.M. Chioffi, "Spatial-temporal coding for wireless communication," *IEEE Trans. Commun.*, vol. 46, pp. 357-366, March 1999.
- [5] G. J. Foschini, "Layered space-time architecture for wireless communication in a fading environment when using multiple-elements antenna," *Bell Labs. Tech. Journal*, vol. 1, pp. 41-59, 1996.
- [6] Muladi, N. Faisal, and S. K. Yusof, "Product coded MIMO system with iterative decoding," in *Proc. Of The IASTED Conf. on Network and Computer Systems*, Krabi- Thailand, 18-20 April 2005.
- [7] J. Lodge, P. Hoeher and J. Hagenauer, "The decoding of multidimensional codes using separable map filtering," in *Proc. 16<sup>th</sup> Queen's Biennial Symp. Comm.*, Kingston, ON, Canada, 1992, pp. 343-346.
- [8] J. Hagenauer, "Iterative decoding of binary block and convolutional codes", *IEEE Trans. Inform. Theory*, vol. 42, pp. 429-445, March 1996.
- [9] J. S. K. Tee, D. P. Taylor, and P. A. Martin, "Multiple serial and parallel concatenated single parity-check codes," *IEEE Trans. on Comm.*, vol. 51, pp. 1666-1675, Oct. 2003.